



QAD Enterprise Applications
Standard and Enterprise Edition

Training Guide **QAD .NET UI Administration**

This document contains proprietary information that is protected by copyright and other intellectual property laws. No part of this document may be reproduced, translated, or modified without the prior written consent of QAD Inc. The information contained in this document is subject to change without notice.

QAD Inc. provides this material as is and makes no warranty of any kind, expressed or implied, including, but not limited to, the implied warranties of merchantability and fitness for a particular purpose. QAD Inc. shall not be liable for errors contained herein or for incidental or consequential damages (including lost profits) in connection with the furnishing, performance, or use of this material whether based on warranty, contract, or other legal theory.

QAD and MFG/PRO are registered trademarks of QAD Inc. The QAD logo is a trademark of QAD Inc.

Designations used by other companies to distinguish their products are often claimed as trademarks. In this document, the product names appear in initial capital or all capital letters. Contact the appropriate companies for more information regarding trademarks and registration.

Copyright ©2013 by QAD Inc.

NETUIAdmin_TG_v2013SE_EE.pdf/sti/sti

QAD Inc.

100 Innovation Place
Santa Barbara, California 93108
Phone (805) 566-6000
<http://www.qad.com>

Contents

Change Summary	xi
About This Course	1
Course Description	2
Objective	2
Audience	2
Prerequisites	2
Course Credit and Scheduling	2
Additional Resources	2
QAD Learning Center	3
QAD Document Library	3
QAD Support	3
Chapter 1 Overview	5
Chapter Objectives	6
Benefits	7
Training Flow	8
Overview	9
QAD .NET UI Benefits	11
Security	12
Rich Functionality	13
Menu System	14
Menu Search	15
Favorites	16
Workspaces and Domains	17
Tabs	18
Enhanced Screens	19
Hide Navigation Pane	20
View Navigation Pane	21
Auto Start	22
Administration Programs	23
Product Structure Maintenance	24
Navigation Buttons	25
Performance	26
Browses	27

Browse Control Bar	28
Excel Export	29
Browse Primary Search	31
Browse Advanced Search	32
Browse Column Filtering	33
Browse Summary	36
Browse Reset	38
Browse Hyperlinks	39
Browse Drill Down	40
Browse Create and Modify Buttons	41
Browse Charting	42
Menu Collections	45
Browse Collections	46
Browse Collection Example	47
Multiple Views	49
External Files as Favorites	51
Connect to Other Applications	52
Exercises	53
Chapter 2 Terminology	55
Chapter Objectives	56
Benefits	57
Training Flow	58
Overview	59
Network Terminology	60
Web Terminology	62
JAVA Terminology	63
Tomcat Terminology	64
.NET Terminology	65
Chapter 3 Components	67
Chapter Objectives	68
Benefits	69
Training Flow	70
Overview	71
NET UI Architecture	72
What Is WebSpeed?	73
WebSpeed Architecture	74
WebSpeed Architecture 1	75
WebSpeed Architecture 2	76
WebSpeed Architecture 3	79
WebSpeed Architecture 4	82

WebSpeed Architecture 5	84
Progress AppServer	85
Tomcat J2EE Application Server	86
Tomcat Overview	87
Tomcat Directories - Key Subdirectories	88
Tomcat Directories - Key .NET UI Directories	89
Tomcat Directories - Attachments	90
Tomcat Directories - Key .NET UI Files	91
Using Tomcat	92
Tomcat Engine Architecture	93
Connection Manager	94
Configuration Settings	96
Monitor Connections and Users	97
.NET UI Client	98
Exercise	99
Chapter 4 QAD .NET UI Administration	101
Chapter Objectives	102
Benefits	103
Training Flow	104
Overview	105
Installation	107
Client Session Configuration	108
System-Wide Logging Settings	111
Configuration Storage Directories	112
Menu Extension Configuration	115
Session Configuration	117
Session Monitoring	119
Session Master Maintenance	120
Connection Manager	121
Heartbeat Monitor	122
User Count Log File	123
Adding Custom Menus	124
Using Attachment Maintenance	128
Enable Attachments to Sales Order Maintenance	129
Attachments to Sales Order Maintenance	130
Active Directory Authentication	131
Enabling Active Directory Authentication	132
Active Directory Limitations	133
Messaging and Workflow Inbox	134
Adding Custom Links	138
Adding Transaction Comments	141
Embedded Telnet Screens	142

Recording Program Actions	149
Exercises	156
Knowledge Check	157
Chapter 5 Multiple Systems	159
Chapter Objectives	160
Benefits	161
Training Flow	162
Multiple Databases: Independent Environment	163
.NET UI Install Review List	164
Database Differences	166
.NET UI Considerations	172
Knowledge Check	174
Chapter 6 Performance Tuning	175
Chapter Objectives	176
Benefits	177
Training Flow	178
Overview	179
Performance Considerations	180
Tomcat Tuning	184
Database Tuning	185
Client Considerations	188
Unix Tools: top	189
Unix Tools: free	190
Unix Monitoring Tool: sar	191
Other Unix Tools	192
Kernel Considerations	193
Kernel Considerations: Max Telnet Connections	194
Kernel Considerations: File Handles	195
Kernel Considerations: Shared Memory	196
Kernel Considerations: Disable Bigpages	197
Kernel Considerations: I/O Scheduler	198
Increase Maximum File Size	199
xinetd.d	200
Additional Resources	201
Knowledge Check	202
Chapter 7 Troubleshooting	203
Chapter Objectives	204
Benefits	205
Training Flow	206

Overview	207
Troubleshooting Basics	208
.NET UI Startup Sequence	209
Troubleshooting Test Points	210
Database Connections	211
Test the Admin and Name Servers	213
Test the WebSpeed Brokers	214
Test the AppServer Brokers	215
Test the WebSpeed Messenger	216
Verify Tomcat Is Running	217
Troubleshooting Aids: who Command	219
Troubleshooting Aids: tail Command	220
Troubleshooting Aids: Logs	221
Trouble Shooting Aids: Informational Commands	222
Troubleshooting Exercise	223
Knowledge Check	224
Chapter 8 Customizing Browsers	225
Chapter Objectives	226
Benefits	227
Training Flow	228
Browse Maintenance	229
Creating a Browse	230
Selecting Fields	231
Using the Query Tab	232
Field Properties	233
Header Data Tab	234
Other Browse Options	235
Performance Considerations and Limitations	236
Browse Performance Controls	237
Table Joins	239
Importing Browsers	240
Exporting Browsers	241
Deleting Multiple Browsers	242
Browse Link Maintenance	243
Creating a Browse Link	244
Exercise	246
Browse URL Maintenance	247
Creating a Browse URL Link to a Program	248
Exercise	249
Creating a Browse Link to a Web Page	250
Exercise	251
Creating a Browse Link to a Record	252

Knowledge Check	254
Chapter 9 Menu and Browse Collections	255
Chapter Objectives	256
Benefits	257
Training Flow	258
Menu Collections	259
Menu Collection Maintenance	260
Browse Collections	261
Browse Collection Maintenance	262
Running Browse Collections	265
Knowledge Check	266
Chapter 10 Process Maps	267
Objectives	268
Benefits	269
Training Flow	270
Overview	271
Process Maps Views	272
Naming Conventions	273
Numbering Conventions	274
Map Titles	275
Breadcrumbs	276
Nodes	277
Viewing Process Maps	279
Creating a Process Map	281
Editing Style Properties	282
Process Map Variables	283
Connector Properties	284
Node Properties	285
Process Map Administration	288
Context Parameters	289
Process Properties	294
Language Support	295
Process Label Maintenance	296
Managing Process Maps	297
Knowledge Check	298
Chapter 11 Configurable Screens	299
Objectives	300
Benefits	301
Training Flow	302

Overview	303
Types of Configuration	304
Users and Templates	305
Error Handling and Template Conflicts	306
Configurable Screens Setup	307
Creating Template	309
Template Considerations	311
Performance Considerations	312
Configure Screen	313
Available Fields	314
Field Properties	315
Adding Lookups to Fields	317
Using Added Fields in Character Code	318
Adding Frames	319
Template Conflicts	321
Configurable Screens Report	324
Exercise	325
Knowledge Check	326

Change Summary

The following table summarizes significant differences between this document and the last published version.

Date/Version	Description	Reference
March 2013EE and SE	Rebranded	--
Sept 2012/2012.1 EE and 2012 SE	Rebranded for QAD 2012.1 EE; Consistency edit	--
March 2012/2012 EE and 2012 SE	Rebranded for QAD 2012 EE and SE	--
Sept 2011/2011.1 EE and 2011 SE	Rebranded for QAD 2011.1 EE	--
Sept 2011/2011.1 EE and 2011 SE	Reorganized and expanded chapters	--
Sept2011/2011.1 EE and 2011 SE	Updated illustrations and screen captures.	--

About This Course

Course Description

This course provides a technical and functional overview of the architecture and use of the QAD .NET UI.

The course includes information on:

- The architecture of QAD's interface tools
- Deployment options for the QAD .NET UI
- Administration of the QAD .NET UI
- Tuning and troubleshooting the installation
- Navigation, browses, and process maps
- Configuring screens

Objective

Learn how to administer and troubleshoot both the Enterprise (EE) and Standard (SE) editions of QAD Enterprise Applications. In addition, students will be able to use browses and process maps effectively and learn how to customize non-component based screens.

Audience

- Implementation consultants
- System administrators

Prerequisites

- Progress 4GL knowledge
- Data model basics
- Knowledge of QAD Enterprise Application architecture concepts
- Familiarity with Enterprise (EE) and Standard (SE) editions of QAD Enterprise Applications

Course Credit and Scheduling

This course is designed to be taught in three days.

Additional Resources

If you encounter questions on QAD software that are not addressed in this book, several resources are available. The QAD corporate Web site provides product and company overviews. From the main site, you can access the QAD Learning or Support site and the QAD Document Library. Access to some portions of these sites depends on having a registered account.

<http://www.qad.com/>

QAD Learning Center

To view available training courses, locations, and materials, use the QAD Learning Center. Choose Education under the Services tab to access this resource. In the Learning Center, you can reserve a learning environment if you want to perform self-study and follow a training guide on your own.

QAD Document Library

To access release notes, user guides, training guides, and installation and conversion guides by product and release, visit the QAD Document Library. Choose Document Library under the Support tab. In the QAD Document Library, you can view HTML pages online, print specific pages, or download a PDF of an entire book.

To find a resource, you can use the navigation tree on the left or use a powerful cross-document search, which finds all documents with your search terms and lets you refine the search by book type, product suite or module, and date published.

QAD Support

Support also offers an array of tools depending on your company's maintenance agreement with QAD. These include the Knowledgebase and QAD Forums, where you can post questions and search for topics of interest. To access these, choose Visit Online Support Center under the Support tab.

Chapter 1

Overview

Chapter Objectives

Chapter Objectives

- The objective of this chapter is to review the features and benefits of the QAD .NET UI

Benefits

Benefits

- You will be familiar with how to use many of the essential features of the QAD .NET UI

Training Flow

Training Flow



- **Overview**
- Terminology
- Components
- Administration Tasks
- Multiple Systems
- Performance Tuning
- Troubleshooting
- Customizing Browsers
- Menu and Browse Collections
- Process Maps
- Configurable Screens

Overview

Overview

- QAD .NET UI Benefits
- Security, Rich Functionality
- Menu System, Menu Search
- Favorites
- Workspaces and Domains
- Tabs, Enhanced Screens
- Hide / View Navigation Pane, Auto Start
- Administration Programs
- Product Structure Maintenance
- Navigation Buttons
- Performance

Overview (continued)

- Browsers
 - Browse Control Bar
 - Excel Export
 - Browse Primary Search, Advanced Search
 - Browse Column Filtering, Summary, Reset,
 - Browse Hyperlinks, Drill-Down, New/Edit, Charting
- Menu and Browse Collections
- Multiple Views
- External Files as Favorites
- Connect to External Applications
- Exercises

QAD .NET UI Benefits

QAD .NET UI Benefits

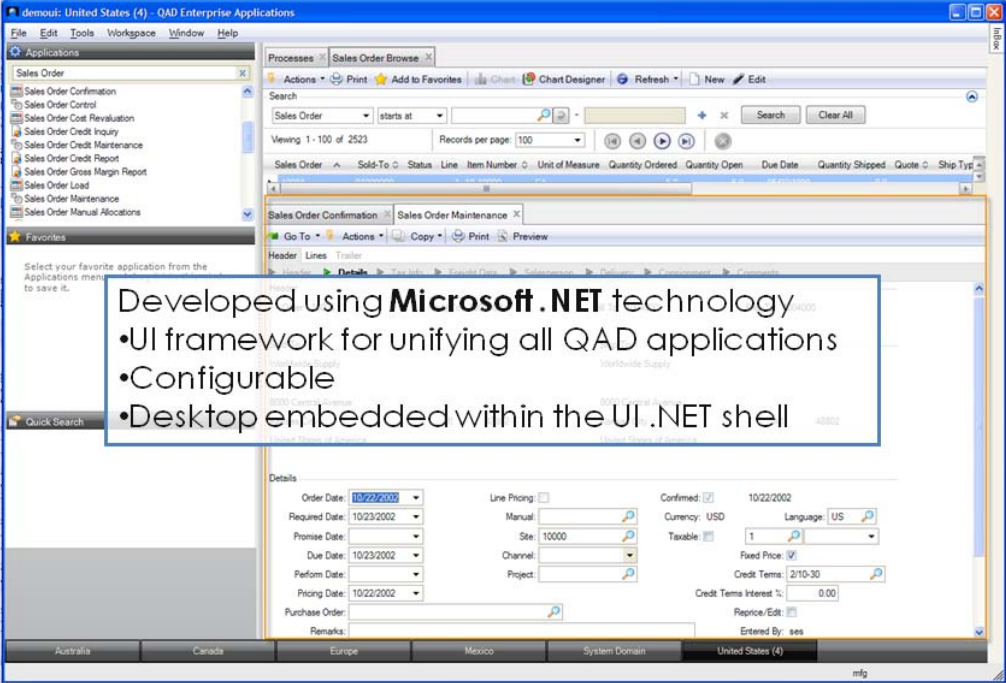

The screenshot displays the QAD .NET UI interface for a sales order. The window title is "demo: United States (4) - QAD Enterprise Applications". The interface includes a menu bar (File, Edit, Tools, Workspace, Window, Help), a toolbar with actions like Print, Add to Favorites, Chart Designer, Refresh, New, and Edit, and a search bar. A list of applications is visible on the left, including Sales Order Confirmation, Sales Order Control, Sales Order Cost Revaluation, Sales Order Credit Inquiry, Sales Order Credit Maintenance, Sales Order Credit Report, Sales Order Gross Margin Report, Sales Order Lead, Sales Order Maintenance, and Sales Order Manual Allocations. The main area shows a sales order form with fields for Order Date, Required Date, Promise Date, Due Date, Perform Date, Pricing Date, Purchase Order, Line Pricing, Manual, Site, Channel, Project, Confirmed, Currency, Language, Taxable, Fixed Price, Credit Terms, Credit Terms Interest %, Reprice/Edit, and Entered By. A text box overlay in the center of the screenshot contains the following text:

Developed using **Microsoft .NET** technology

- UI framework for unifying all QAD applications
- Configurable
- Desktop embedded within the UI .NET shell

The QAD logo is visible in the bottom left corner, and the text "A DM_OVER_070" is in the bottom right corner.

Security

Security

Security

- Supports SSL (secure Web connection via https://)
- Existing security model (menu, groups, roles)

The screenshot displays the QAD Enterprise Applications .NET UI. The main window shows a list of sales orders with columns for Sales Order, Sold-To, Status, Line, Item Number, Unit of Measure, Quantity Ordered, Quantity Open, Due Date, Quantity Shipped, Quote, and Ship Type. Below the list, a detailed view of a sales order is shown, including fields for Order Date, Required Date, Promise Date, Line Pricing, Manual, Confirmed, Currency, and Language. The QAD logo is visible in the bottom left corner, and the text 'ADM_OVER_080' is in the bottom right corner.

Rich Functionality

Rich Functionality

The screenshot displays the QAD Enterprise Applications interface. On the left, there is a navigation pane with sections for 'Menu Search', 'Favorites', and 'Quick Search'. The 'Menu Search' section includes 'Customer Services', 'Master Data', 'Supply Chain', 'Processes', 'Process Maps', 'Vertical Industry View', 'Supply Chain View', and 'Operational Metrics View'. The 'Favorites' section includes 'Sales', 'Sales Ord.', 'Admin', 'Connecti', 'Browse C', 'Tomcat M', 'Attachme', and 'Configur'. The 'Quick Search' section is empty. The main content area shows the 'Vertical Industry View' with a 'Vertical Industry Process Model' diagram. The diagram consists of several interconnected nodes representing different stages of a process. The footer of the interface includes navigation tabs for 'Australia', 'Canada', 'Europe', 'Mexico', 'System Domain', and 'United States (2)', along with a 'mfg' label.

- Calling programs by menu, alias and program names
- Configurable screens
- Process maps
 - Use Microsoft Silverlight
 - Process Maps for each vertical industry
 - Adobe SVG is used to create and modify the process maps

Menu System

Menu System

The screenshot displays the QAD Enterprise Applications interface. On the left, a 'Menu Search' pane shows a hierarchical tree structure under 'Applications' and 'Favorites'. The main window shows a 'Sales Order Browse' table with columns for 'Sales Order', 'starts at', and 'Records per page'. A callout box with a blue border and white background is overlaid on the table, containing the following text:

- Hierarchical structure
- New icons
- Dynamic presentation based on security

Below the callout, the 'Sales Order Maintenance' form is visible, showing fields for 'Order', 'Sold-To', 'Bill To', and 'Ship-To'. The bottom of the interface features a navigation bar with tabs for 'Australia', 'Canada', 'Europe', 'Mexico', 'System Domain', and 'United States (2)'. The QAD logo is in the bottom left corner, and 'ADM_OVER_100' is in the bottom right corner.

Menu Search

Menu Search

The screenshot displays the QAD Enterprise Applications interface. A 'Menu Search' window is open on the left, showing a tree view of application menus. A callout box with the text 'Dynamic menu filtering as you type' is positioned over the search input field in the 'Menu Search' window. The main window shows a 'Sales Order Browse' screen with a table of sales order lines. Below the table is a 'Sales Order Maintenance' form with fields for Order, Sold-To, Bill To, and Ship-To.

Sales Order	Sold-To	Status	Line	Item Number	Unit of Measure	Quantity Ordered	Quantity Open	Due Date	Quantity Shipped	Quote	Ship Type
10001	01000000		1	10-10000	EA	5.0	5.0	09/02/1998	0.0		
10001	01000000		2	90-100	EA	50.0	50.0	01/26/1998	0.0		
10001	01000000		3	90-110	EA	200.0	200.0	01/26/1998	0.0		
10005	1004000		1	color_400	EA	20.0	20.0	10/23/2002	0.0		
10006	00010002		1	icb100-45	EA	100.0	0.0	10/23/2002	100.0		
10006	00010002		2	icb200-45	EA	150.0	0.0	10/23/2002	150.0		
10007	00010005		1	icb100-45	EA	200.0	0.0	10/23/2002	200.0		
10007	00010005		2	icb200-45	EA	125.0	0.0	10/23/2002	125.0		
10008	00010005		1	95-0079	EA	1.0	1.0	10/23/2002	0.0		



Favorites

Favorites

The screenshot shows the QAD Enterprise Applications interface. The 'Favorites' pane on the left contains a list of programs and folders. A text box titled 'Favorites' is overlaid on the interface, listing the following capabilities:

- Drag-and-drop programs and folders
- Rename programs
- Create custom folders

The background interface shows a 'Sales Order Browse' window with a table of sales orders. The table has columns: Sales Order, Sold-To, Status, Line, Item Number, Unit of Measure, Quantity Ordered, Quantity Open, Due Date, Quantity Shipped, Quote, and Ship Type. The table contains several rows of data, including sales orders 10001, 10001, 10001, 10004, 10001, 10001, 10001, and 10001.

The interface also shows a 'Header' section with fields for Order, Sold-To, Bill To, and Ship-To. The bottom of the interface shows a navigation bar with tabs for Australia, Canada, Europe, Mexico, System Domain, and United States (2).

Workspaces and Domains

Workspaces and Domains

Sales Order	Sold-To	Status	Line	Item Number	Unit of Measure	Quantity Ordered	Quantity Open	Due Date	Quantity Shipped	Quote	Ship Typ
10000	01000000		1	1010000	EA	1.0	1.0	01/26/1998	0.0		
10001	01000000		2	90-100	EA	50.0	50.0	01/26/1998	0.0		
10001	01000000		3	90-110	EA	200.0	200.0	01/26/1998	0.0		
10005	1004000		1	color_400	EA	20.0	20.0	10/23/2002	0.0		
10006	00010002		1	icb100-45	EA	100.0	0.0	10/23/2002	100.0		
10006	00010002		2	icb200-45	EA	150.0	0.0	10/23/2002	150.0		
10007	00010005		1	icb100-45	EA	200.0	0.0	10/23/2002	200.0		
10007	00010005		2	icb200-45	EA	125.0	0.0	10/23/2002	125.0		
10008	00010005		1	95-0079	PA	1.0	1.0	10/24/2002	0.0		

Workspace and Domains

- New navigation
- Security defined workspace access

Australia Canada Europe Mexico System Domain United States (2)



Tabs

Tabs

The screenshot displays the QAD Enterprise Applications interface with multiple tabs open. The main window shows a 'Customer Browse' tab with a search bar and a data table. Below it, a 'Sales Order Maintenance' tab is visible. A text box highlights the 'Tabs' feature with the following list:

- Open multiple Browsers and Maintenance screens
- Split screens (vertical and horizontal)
- Simple resizing and restore
- Detachable to new window

The data table in the 'Customer Browse' tab contains the following information:

Customer	Sort Name	Region	Country	Salesperson	Type	Site	Language
00010000	University of Cal - Site To		United States of America			10000	
00010001	University of California	US	United States of America		DIST	10000	us
00010002	Consigned Inventory Customer	MW	United States of America	HDA	net	10000	us
00010003	Toy Company of America	US	United States of America		DIST	PRM Site	US
00010005	Consigned Inventory Customer	US	United States of America	HDA	DIST	10000	us
00010006	Customer	US	United States of America		net	MainSite	us
00011111	UCIrvine		United States of America	HDA	net	10000	
00050004	Spare Parts Warehouse	US	United States of America		POC	10000	us
001	PEI Computers Ltd.	CAN	Canada		net	11000	US
0000	USA - Main Public	US	United States of America		net	10000	us



Enhanced Screens

Enhanced Screens

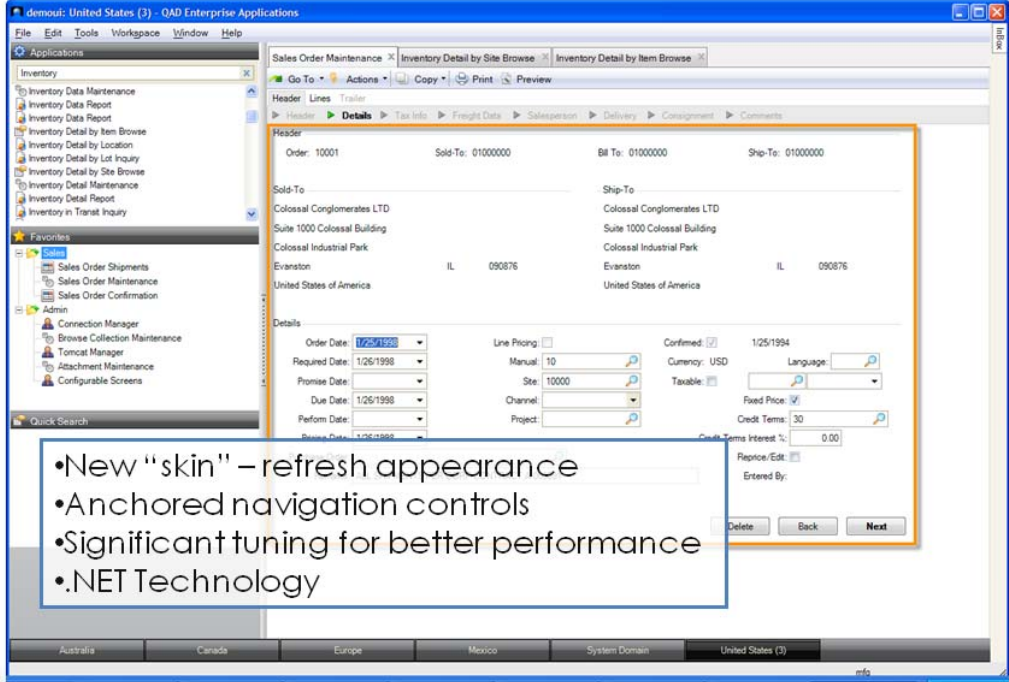

- New "skin" – refresh appearance
- Anchored navigation controls
- Significant tuning for better performance
- .NET Technology



Hide Navigation Pane

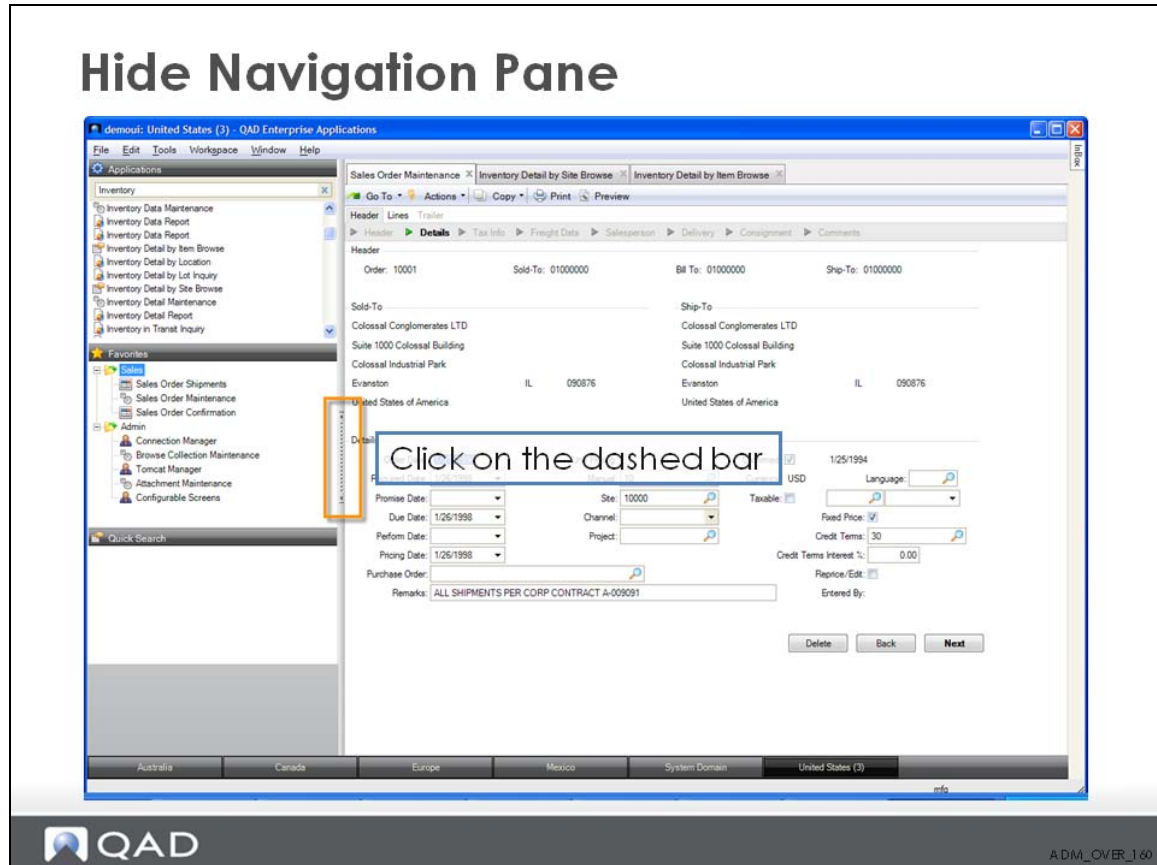

View Navigation Pane

View Navigation Pane

The screenshot displays the QAD Enterprise Applications interface. At the top, there is a menu bar with 'File', 'Edit', 'Tools', 'Workspace', 'Window', and 'Help'. Below the menu bar are several tabs: 'Sales Order Maintenance', 'Inventory Detail by Site Browse', and 'Inventory Detail by Item Browse'. A toolbar contains icons for 'Go To', 'Actions', 'Copy', 'Print', and 'Preview'. The main content area is divided into sections: 'Header', 'Lines', and 'Trailer'. The 'Header' section is currently selected and shows details for 'Order: 10001', including 'Sold-To' and 'Ship-To' information for 'Colossal Conglomerates LTD'. A callout box with a dashed border points to a vertical dashed bar on the left side of the 'Header' section, with the text 'Click on the dashed bar again'. Below the header information are various input fields for dates, currency, and other order details. At the bottom of the window, there is a navigation bar with buttons for 'Delete', 'Back', and 'Next', and a status bar showing 'United States (3)'.

Click on the dashed bar again

QAD

A DM_OVER_170

Auto Start

Auto Start

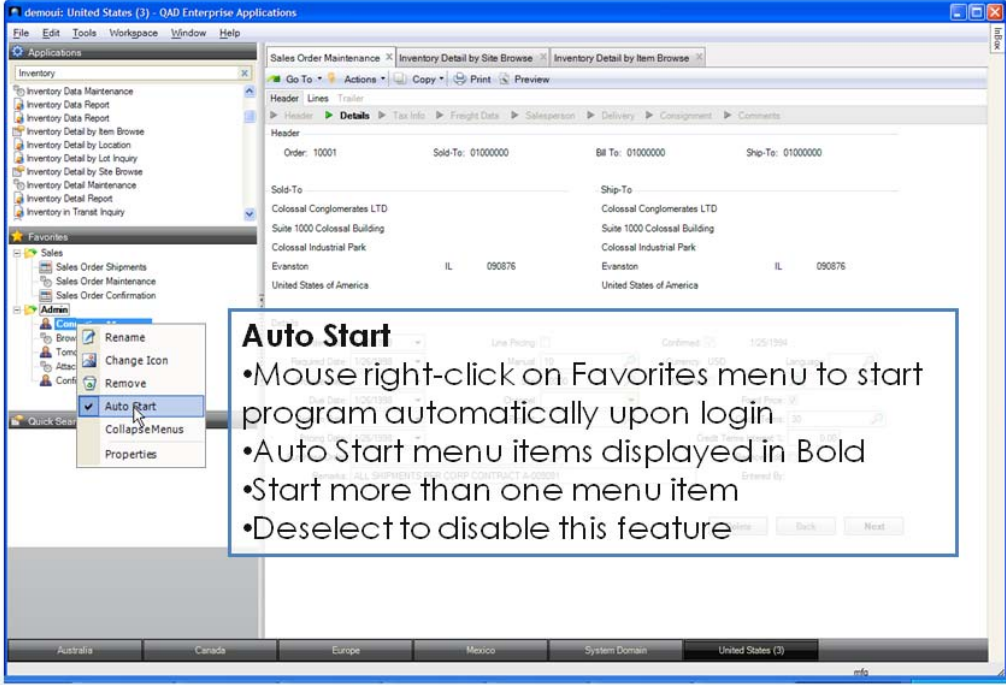

The screenshot shows the QAD Enterprise Applications interface. The 'Favorites' menu is open, and the 'Auto Start' option is highlighted. A text box explains the 'Auto Start' feature:

- Mouse right-click on Favorites menu to start program automatically upon login
- Auto Start menu items displayed in Bold
- Start more than one menu item
- Deselect to disable this feature

The interface also shows a 'Sales Order Maintenance' window with details for Order 10001, including Sold-To and Ship-To information for Colossal Conglomerates LTD.

QAD

A DM_ OVER_180

Administration Programs

Administration Programs

The screenshot shows the QAD Enterprise Applications interface for Administration Programs. A text box with a blue border and white background is overlaid on the Administration menu, containing the text "Only authorized users can access". The menu items include: Administration, Browse Collection Maintenance, Menu Collection Maintenance, Attachment Maintenance, Tomcat Manager, Connection Manager, Configurable Screens, Process Admin, Process Editor, Process Label Maintenance, Create Metric Group, and Execute Document Import. The main window displays a Sales Order Maintenance form for Order 10001, with details for Suite 1000 Colossal Building, Colossal Industrial Park, Evanston, IL 090876, United States of America. The form includes fields for Order Date, Required Date, Promise Date, Due Date, Perform Date, Pricing Date, Purchase Order, Line Pricing, Manual, Site, Channel, Project, Confirmed, Currency, Taxable, Fixed Price, Credit Terms, Credit Terms Interest %, Reprice/Edit, and Entered By. Buttons for Delete, Back, and Next are visible at the bottom right of the form.



Navigation Buttons

Navigation Buttons

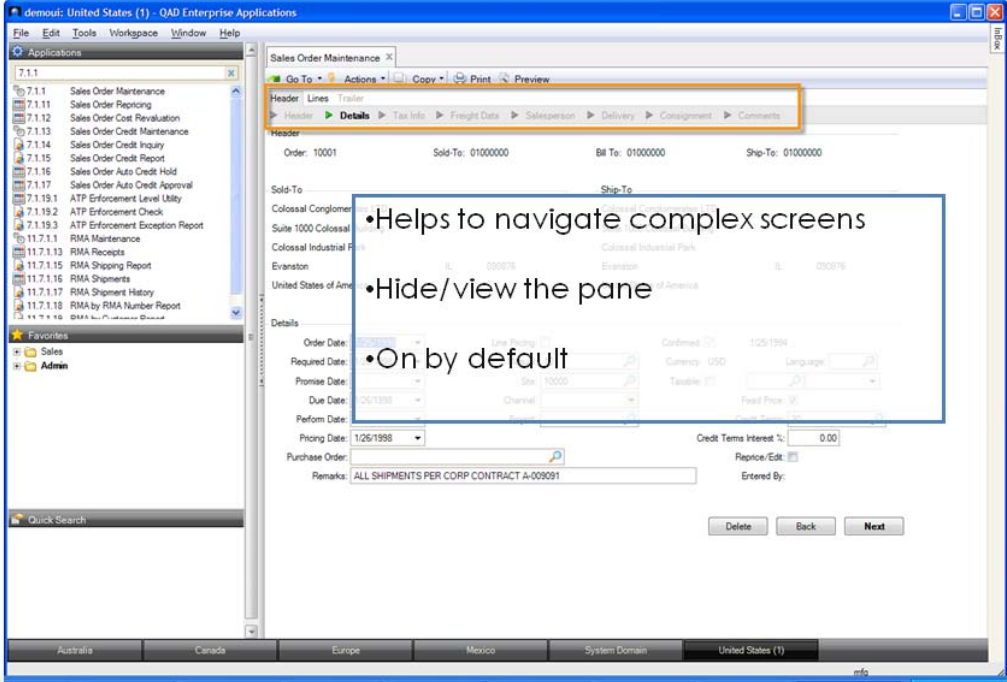

Performance

Performance

The screenshot displays the QAD Enterprise Applications interface. The main window is titled "Sales Order Browse" and shows a table of sales orders. Overlaid on this is a text box with the following bullet points:

- New browses perform faster than previous Java browses
- New desktop screens perform faster within .NET framework
- Scalable

Below the text box is a line chart titled "Performance: Embedded Screens v.s. Desktop Customer Credit Inquiry / Unplanned Issues / Unplanned Receipts". The chart compares performance across various screens for different regions. The Y-axis represents performance, ranging from 0 to 24. The X-axis lists screens: Customer, Customer SO, Customer Output, ULPark, ULPdy, ULPOrder, ULPconfirm, ULPark, ULPdy, ULPOrder, ULPconfirm, and Logout. The chart shows three lines: a blue line (highest performance), an orange line (middle performance), and a yellow line (lowest performance). The blue line generally shows the highest performance, peaking around 22 for ULPdy and ULPOrder. The orange line peaks around 18 for ULPdy and ULPOrder. The yellow line peaks around 12 for ULPdy and ULPOrder.

Screen	Blue Line	Orange Line	Yellow Line
Customer	12	10	8
Customer SO	12	10	8
Customer Output	12	10	8
ULPark	12	10	8
ULPdy	22	18	12
ULPOrder	22	18	12
ULPconfirm	12	10	8
ULPark	12	10	8
ULPdy	22	18	12
ULPOrder	22	18	12
ULPconfirm	12	10	8
Logout	12	10	8



Browsets

Browsets

The screenshot shows a software window titled "demo: United States (1) - QAD Enterprise Applications" with a menu bar (File, Edit, Tools, Workspace, Window, Help) and a toolbar. The main area displays a "Sales Order Browse" search interface with a search bar and a data table. The table has columns: Sales Order, Sold-To, Status, Line, Item Number, Unit of Measure, Quantity Ordered, Quantity Open, Due Date, Quantity Shipped, Quote, Ship Type, Purchase Order, Ship-To, Site, and Customer Item. A semi-transparent box is overlaid on the table, containing a list of features.

Sales Order	Sold-To	Status	Line	Item Number	Unit of Measure	Quantity Ordered	Quantity Open	Due Date	Quantity Shipped	Quote	Ship Type	Purchase Order	Ship-To	Site	Customer Item
10001	01000000		1	90-100	EA	50.0	50.0	01/26/1998	0.0				01000000	10000	COL-COL-10000
10001	01000000		2	90-100	EA	50.0	50.0	01/26/1998	0.0				01000000	10000	
10001	01000000		3	90-110	EA	200.0	200.0	01/26/1998	0.0				01000000	10000	
10005	10040000		1	color_400	EA	20.0	20.0	10/23/2007	0.0				10040000	10000	

- Redeveloped using Microsoft .Net technology
- Consistent functionality with Lookups
- Tuned for performance
- Drag columns to new locations to change order
- Columns can be sorted in ascending or descending order
- Memory – layout changes are saved and restored
- Legacy browsets (also customised) are supported
- No need to compile new browsets
- Search criteria can be saved



Browse Control Bar

Browse Control Bar

Navigation buttons: *First, Previous, Next, Last*

- Can optionally download ALL records (with constraints!)
- Export to Excel enhanced
- Print (Preview from File menu)
- Save & Load: Save Browse settings for sharing with other users
- Chart Designer
- Ability to create new or change existing record

Sales Order	Sold-To	Status	Line	Item Number	Unit of Measure	Quantity Ordered	Quantity Open	Due Date	Quantity Shipped	Quote	Ship Type	Purchase Order	Ship-To	Site	Customer Item
10001	01000000		1	10-10000	EA	50.0	50.0	05/02/1998	0.0				01000000	10000	COL-COR-10000
10001	01000000		2	90-100	EA	50.0	50.0	01/26/1998	0.0				01000000	10000	
10002	custA		1	frgpo0-001	EA	3.0	3.0	10/02/2003	0.0				custA	Central	
10021	custA		1	frgpo0-001	EA	3.0	3.0	10/02/2003	0.0			po10021	custA	Central	
10022	custA		1	frgpo0-001	EA	1.0	1.0	10/02/2003	0.0				custA	Central	
10040	01000000		1	100634	EA	10.0	10.0	05/01/2004	0.0				01000000	100	
10041	01000000		1	100634	EA	5.0	5.0	05/01/2004	0.0				01000000	100	
10042	01000000		1	100634	EA	1.0	1.0	05/01/2004	0.0				01000000	100	
1234	01000000		1	90-100	EA	0.0	-150.0		150.0				01000000	10000	
200008	WANA		1	6543	EA	100.0	100.0	07/23/2001	0.0				WANA	10000	

Excel Export

Excel Export

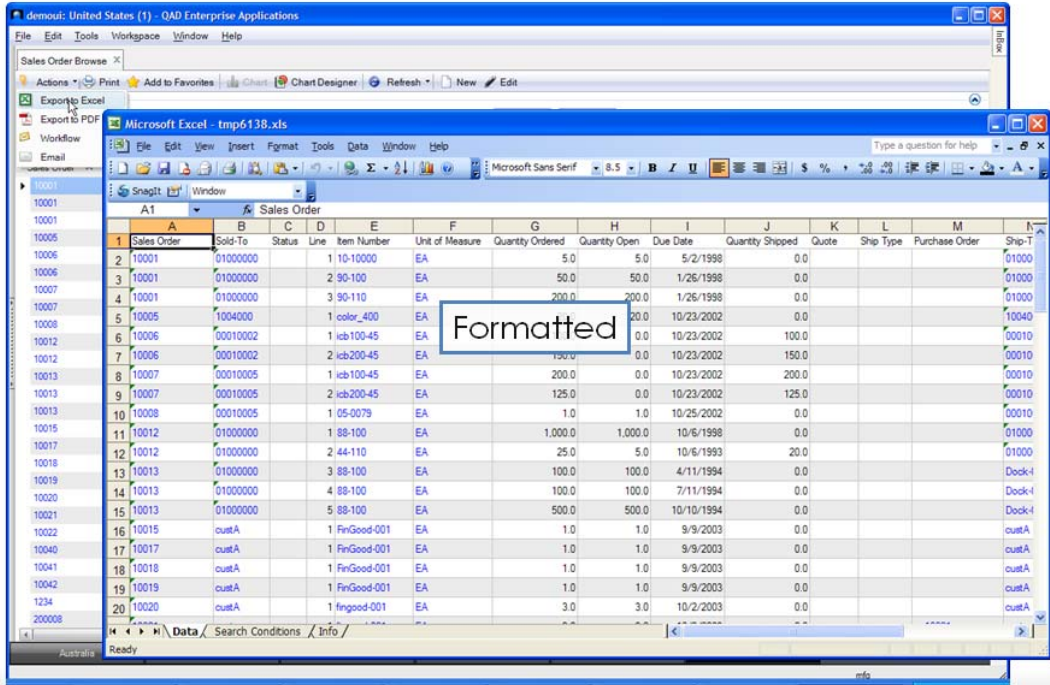

Excel Export

The screenshot shows the QAD Enterprise Applications interface with an Excel export window open. The Excel window displays a table with the following data:

Name	Value
User ID	mfg
Query Date	10/8/2009 4:24:29 PM
Browse Name	Sales Order Browse
Browse Program	sobr009.p

A text box in the center of the Excel window states: "Additional information is passed in the 3rd Excel worksheet".

Browse Primary Search

Browse Primary Search

The screenshot shows the 'Sales Order Browse' window in QAD Enterprise Applications. The search criteria are defined as follows:

- Sales Order: starts at 1000
- Sold-To: WANA

Buttons for 'Search' and 'Clear All' are visible next to the search fields. A blue box highlights the search criteria and buttons, with the following text:

- Define search criteria
- Search and Clear buttons for easy navigation

Sales Order	Line	Item Number	Unit of Measure	Quantity Ordered	Quantity Open	Due Date	Quantity Shipped	Quote	Ship Type	Purchase Order
200008	1	6543	EA	100.0	100.0	07/23/2001	0.0			
200009	2	6543	EA	4.0	4.0	07/23/2001	0.0			
200010	3	6543	EA	3.0	3.0	05/15/2001	0.0			
200014	1	0300000	EA	1.0	1.0	05/15/2001	0.0			
200016	1	0300003	EA	2.0	2.0	05/15/2001	0.0			
200017	1	0300001	EA	3.0	3.0	05/15/2001	0.0			
200018	1	0300002	EA	1.0	1.0	05/15/2001	0.0			
200019	2	0300001	EA	20.0	20.0	05/15/2001	0.0			
200022	1	6543	EA	5.0	5.0	06/14/2001	0.0			PO 20010
200023	1	6543	EA	1.0	1.0	05/15/2001	0.0			
200024	1	87543	EA	1.0	1.0	05/15/2001	0.0			
200025	1	0300002	EA	1.0	1.0	05/16/2001	0.0			
200026	2	0300003	EA	2.0	2.0	05/16/2001	0.0			
200027	1	0300001	EA	1.0	1.0	05/16/2001	0.0			
200028	2	87543	EA	1.0	1.0	05/16/2001	0.0			
200029	4	87543	EA	1.0	1.0	05/16/2001	0.0			
200030	5	87543	EA	1.0	1.0	05/16/2001	0.0			
200031	2	6543	EA	100.0	100.0	05/16/2001	0.0			PO123
200032	3	6543	EA	100.0	100.0	05/16/2001	0.0			PO123
200033	7	87543	EA	1.0	1.0	05/16/2001	0.0			
200034	6	87543	EA	1.0	1.0	05/16/2001	0.0			
200035	1	6543	EA	7.0	7.0	05/20/2001	0.0			PO 200015
200036	2	6543	EA	8.0	8.0	05/26/2001	0.0			PO 200015
200037	3	6543	EA	150.0	150.0	05/26/2001	0.0			EXPLORE



Browse Advanced Search

Browse Advanced Search

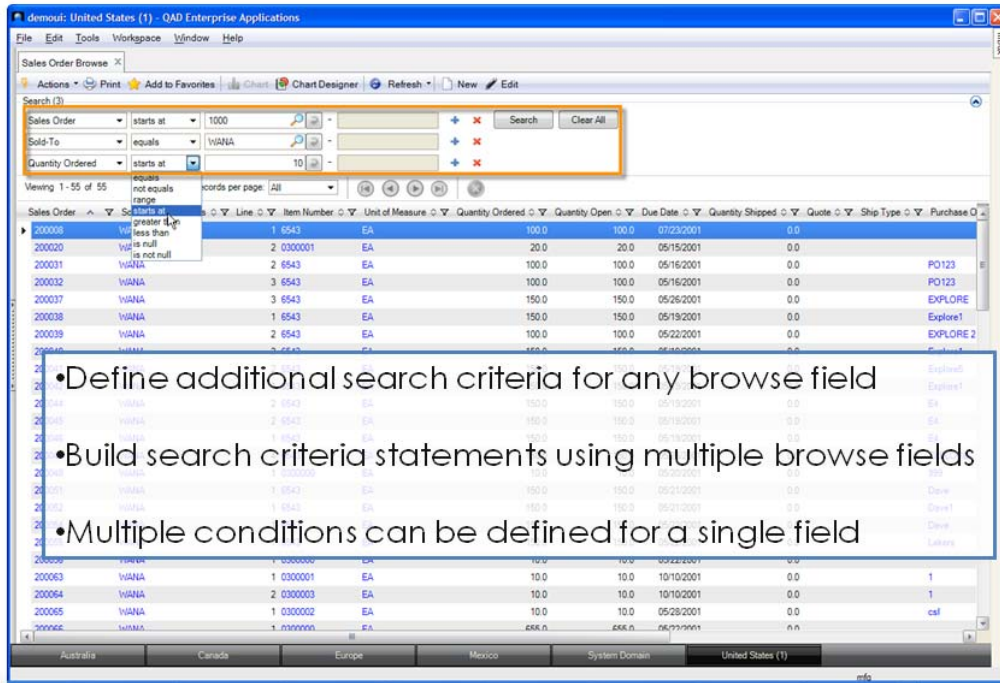

demou: United States (1) - QAD Enterprise Applications

Sales Order Browse

Search (3)

Sales Order starts at 1000

Sold-To equals WANA

Quantity Ordered starts at 10

Viewing 1-55 of 55 records per page: All

Sales Order	Line	Item Number	Unit of Measure	Quantity Ordered	Quantity Open	Due Date	Quantity Shipped	Quote	Ship Type	Purchase Order
200009	1	6543	EA	100.0	100.0	07/23/2001	0.0			
200020	2	0300001	EA	20.0	20.0	05/15/2001	0.0			
200031	2	6543	EA	100.0	100.0	05/16/2001	0.0			PO123
200032	3	6543	EA	100.0	100.0	05/16/2001	0.0			PO123
200037	3	6543	EA	150.0	150.0	05/26/2001	0.0			EXPLORE
200038	1	6543	EA	150.0	150.0	05/19/2001	0.0			EXPLORE1
200039	2	6543	EA	100.0	100.0	05/22/2001	0.0			EXPLORE2
200040	2	6543	EA	150.0	150.0	05/18/2001	0.0			EXPLORE3
200041	2	6543	EA	150.0	150.0	05/18/2001	0.0			EXPLORE4
200042	2	6543	EA	150.0	150.0	05/18/2001	0.0			EXPLORE5
200043	2	6543	EA	150.0	150.0	05/18/2001	0.0			EXPLORE6
200044	2	6543	EA	150.0	150.0	05/18/2001	0.0			EXPLORE7
200045	2	6543	EA	150.0	150.0	05/18/2001	0.0			EXPLORE8
200046	1	6543	EA	150.0	150.0	05/18/2001	0.0			EXPLORE9
200047	1	6543	EA	150.0	150.0	05/18/2001	0.0			EXPLORE10
200048	1	6543	EA	150.0	150.0	05/18/2001	0.0			EXPLORE11
200049	1	6543	EA	150.0	150.0	05/18/2001	0.0			EXPLORE12
200050	1	6543	EA	150.0	150.0	05/18/2001	0.0			EXPLORE13
200051	1	6543	EA	150.0	150.0	05/21/2001	0.0			EXPLORE14
200052	1	6543	EA	150.0	150.0	05/21/2001	0.0			EXPLORE15
200053	1	6543	EA	150.0	150.0	05/21/2001	0.0			EXPLORE16
200054	1	6543	EA	150.0	150.0	05/21/2001	0.0			EXPLORE17
200055	1	6543	EA	150.0	150.0	05/21/2001	0.0			EXPLORE18
200056	1	6543	EA	150.0	150.0	05/21/2001	0.0			EXPLORE19
200057	1	6543	EA	150.0	150.0	05/21/2001	0.0			EXPLORE20
200058	1	0300002	EA	10.0	10.0	09/22/2001	0.0			
200063	1	0300001	EA	10.0	10.0	10/10/2001	0.0			1
200064	2	0300003	EA	10.0	10.0	10/10/2001	0.0			1
200065	1	0300002	EA	10.0	10.0	05/28/2001	0.0			csf
200066	1	0300001	EA	666.0	666.0	06/22/2001	0.0			

- Define additional search criteria for any browse field
- Build search criteria statements using multiple browse fields
- Multiple conditions can be defined for a single field

Browse Column Filtering

Browse Column Filtering

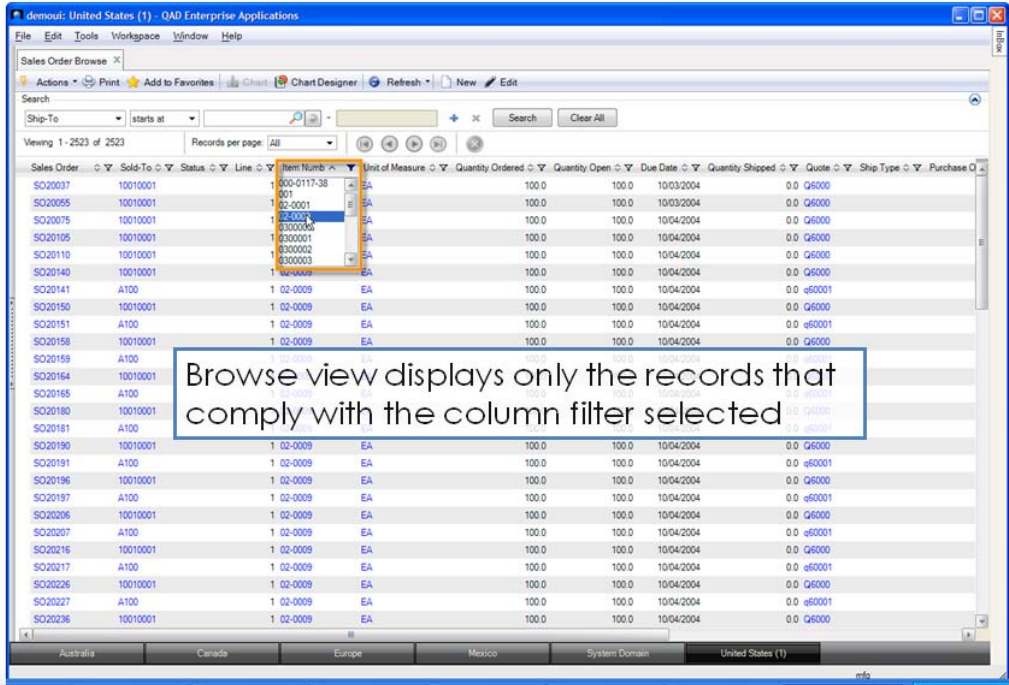

Browse Column Filtering

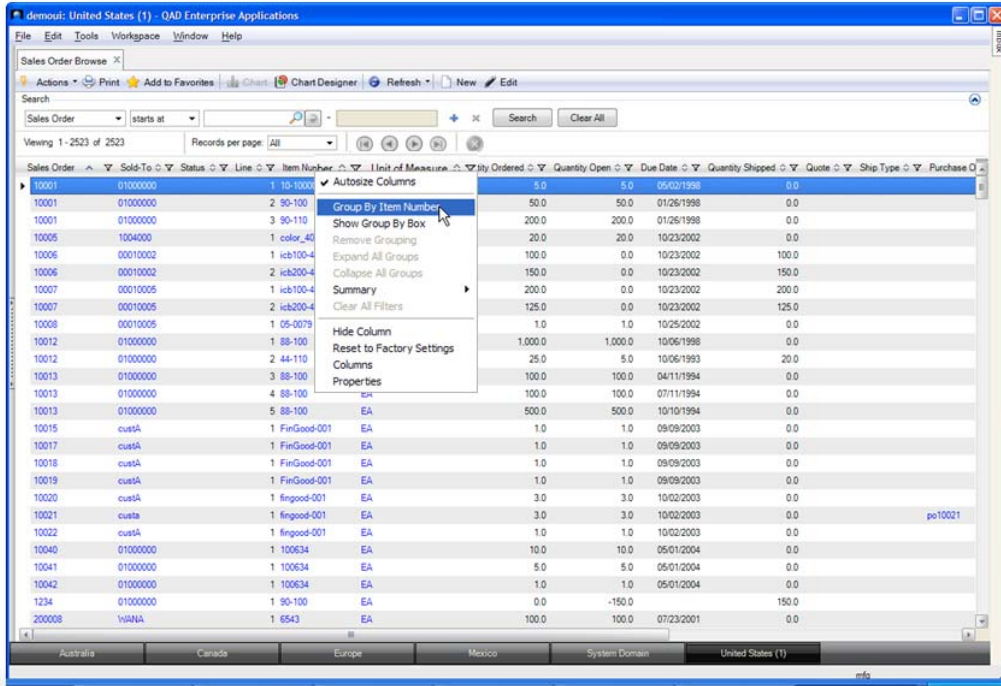

Browse Column Filtering

The screenshot shows the 'Sales Order Browse' window in QAD Enterprise Applications. The window title is 'Memphis: United States (1) - QAD Enterprise Applications'. The menu bar includes File, Edit, Tools, Workspace, Window, and Help. Below the menu bar, there are buttons for Actions, Print, Add to Favorites, Chart Designer, Refresh, New, and Edit. A search bar is present with a search button and a 'Clear All' button. The main area displays a table of sales orders with columns: Sales Order, Sold-To, Status, Line, Unit of Measure, Quantity Ordered, Quantity Open, Due Date, Quantity Shipped, Quote, Ship Type, Purchase Order, and Ship-To. The table is filtered to show sales orders starting with 'SO33352' through 'SO33356'. The table has a scroll bar on the right. At the bottom of the window, there are tabs for Australia, Canada, Europe, Mexico, System Domain, and United States (1). The 'United States (1)' tab is selected.

Sales Order	Sold-To	Status	Line	Unit of Measure	Quantity Ordered	Quantity Open	Due Date	Quantity Shipped	Quote	Ship Type	Purchase Order	Ship-To
SO33352	john		1	EA	1.0	1.0	10/27/2005	0.0				john
SO33353	john		1	EA	1.0	1.0	10/27/2005	0.0				john
SO33354	john		1	EA	1.0	1.0	10/27/2005	0.0				john
SO33355	Canada		1	EA	1.0	1.0	10/27/2005	0.0				Canad
SO33356	AUSSIE		1	EA	1.0	1.0	10/27/2005	0.0				AUSSIE

Browse Summary

Browse Summary

The screenshot shows the 'Sales Order Browse' window in QAD Enterprise Applications. A context menu is open over a numeric field in the table, displaying options for data aggregation: Count, Sum, Average, Minimum, and Maximum. A text box highlights these options with the text: 'Numeric fields have options : Count, Sum, Avg, Min, Max'.

Sales Order	Sold-To	Status	Line	Item Number	Unit of Measure	Quantity Ordered	Quantity Open	Due Date	Quantity Shipped	Quote	Ship Type	Purchase O
10001	01000000		1	10-10000	EA	0.0	0.0	09/02/1998	0.0			
10001	01000000		2	90-100	EA	3.0	3.0	01/26/1998	0.0			
10001	01000000		3	90-110	EA	3.0	3.0	01/26/1998	0.0			
10005	1004000		1	color_400	EA	3.0	3.0	10/23/2002	0.0			
10006	00010002		1	icb100-45	EA	3.0	3.0	10/23/2002	100.0			
10006	00010002		2	icb200-45	EA	3.0	3.0	10/23/2002	150.0			
10007	00010005		1	icb100-45	EA	3.0	3.0	10/23/2002	200.0			
10007	00010005		2	icb200-45	EA	3.0	3.0	10/23/2002	125.0			
10008	00010005		1	05-2029	EA	1.0	1.0	10/25/2002	0.0			
10012	01000000		1	10000000	EA	100.0	100.0	05/01/2004	0.0			
10012	01000000		2	100634	EA	10.0	10.0	05/01/2004	0.0			
10013	01000000		1	10000000	EA	100.0	100.0	07/11/1994	0.0			
10013	01000000		2	100634	EA	500.0	500.0	10/10/1994	0.0			
10015	custA											
10017	custA		1	FinGood-001	EA	1.0	1.0	09/09/2003	0.0			
10018	custA		1	FinGood-001	EA	1.0	1.0	09/09/2003	0.0			
10019	custA		1	FinGood-001	EA	1.0	1.0	09/09/2003	0.0			
10020	custA		1	fingood-001	EA	3.0	3.0	10/02/2003	0.0			
10021	custA		1	fingood-001	EA	3.0	3.0	10/02/2003	0.0			po10021
10022	custA		1	fingood-001	EA	1.0	1.0	10/02/2003	0.0			
10040	01000000		1	100634	EA	10.0	10.0	05/01/2004	0.0			
10041	01000000		1	100634	EA	5.0	5.0	05/01/2004	0.0			
10042	01000000		1	100634	EA	1.0	1.0	05/01/2004	0.0			
1234	01000000		1	90-100	EA	0.0	-150.0		150.0			
200008	VMANA		1	6543	EA	100.0	100.0	07/23/2001	0.0			

Browse Summary

The screenshot shows the 'Sales Order Browse' window in QAD Enterprise Applications. The window title is 'demo: United States (1) - QAD Enterprise Applications'. The interface includes a menu bar (File, Edit, Tools, Workspace, Window, Help), a toolbar with buttons for Print, Add to Favorites, Chart Designer, Refresh, New, and Edit, and a search bar. The main area displays a list of sales orders with columns for Sold-To, Status, Line, Item Number, Unit of Measure, Quantity Ordered, Quantity Open, Due Date, Quantity Shipped, Quote, Ship Type, Purchase Order, and Ship-To. Three summary rows are highlighted with orange boxes, showing the total quantity ordered for each sales order. A callout box with a blue border and white background points to the summary row for Sales Order 10013, containing the text 'Displayed in summaries area below the column'. The bottom of the window features a navigation bar with buttons for Australia, Canada, Europe, Mexico, System Domain, and United States (1).

Sales Order	Quantity Ordered	Quantity Open	Due Date	Quantity Shipped	Quote	Ship Type	Purchase Order	Ship-To
10001	255.0							
10005	20.0							
10006	250.0							
10007	325.0							
10008	1.0							
10012	1,025.0							
10013	700.0							
10015	1.0							
10017	1.0							
10018	1.0							
10019	1.0							
10020	3.0							
10021	3.0							
10022	1.0							
10040	10.0							



Browse Reset

Browse Reset

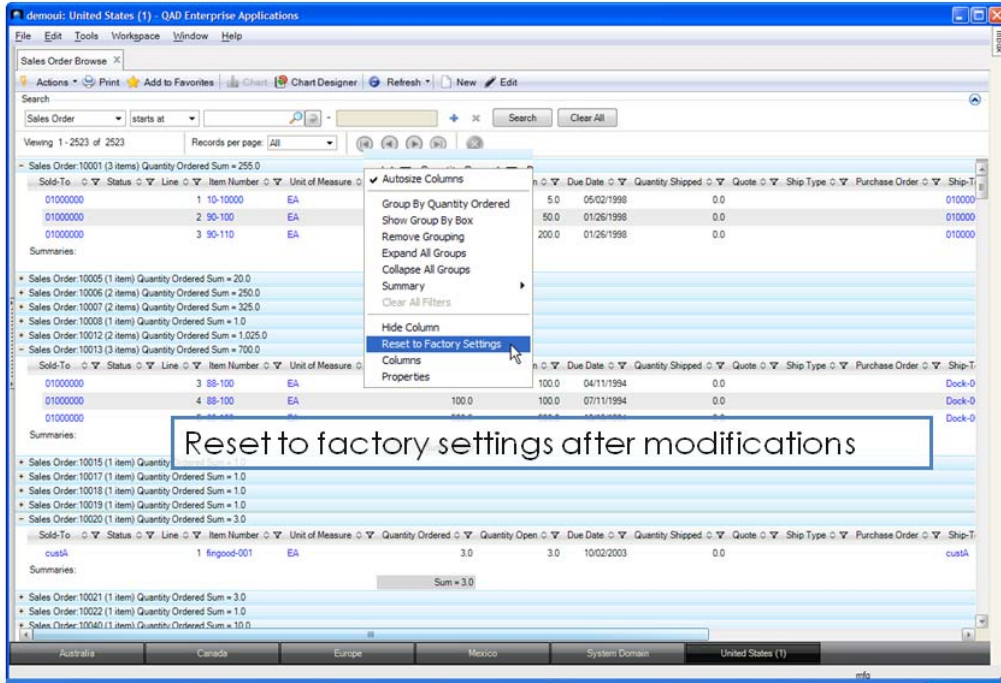

Browse Hyperlinks

Browse Hyperlinks

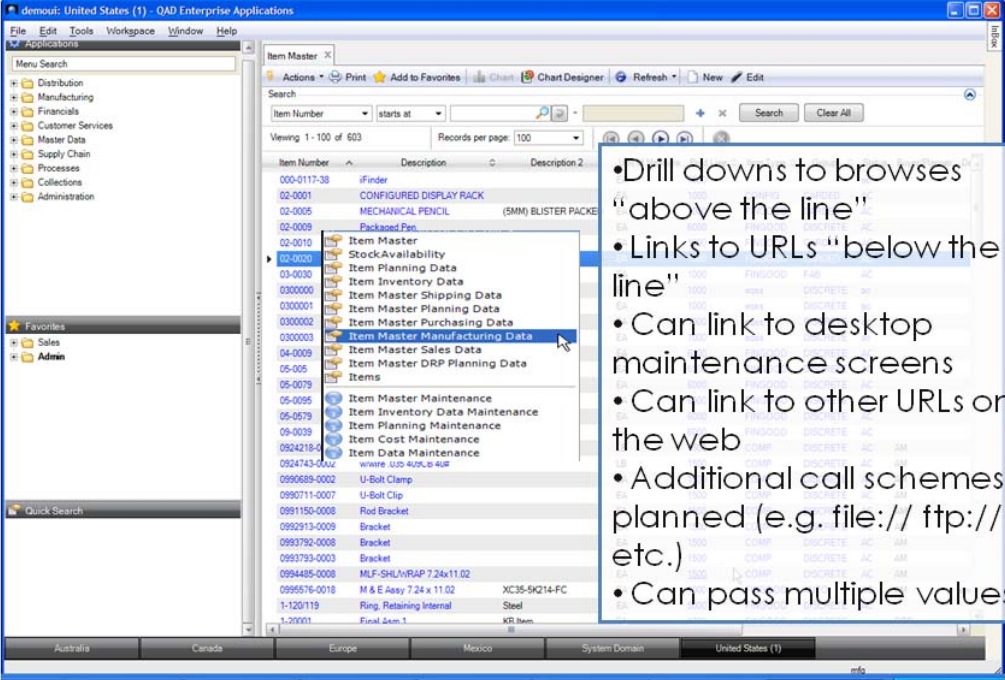

The screenshot shows the QAD Enterprise Applications interface. On the left is a navigation tree with categories like Distribution, Manufacturing, Financials, Customer Services, Master Data, Supply Chain, Processes, Collections, and Administration. The main window displays an 'Item Master' list with columns for Item Number, Description, and Description 2. A context menu is open over the item '02-0010', showing options such as Item Master, StockAvailability, Item Planning Data, Item Inventory Data, Item Master Shipping Data, Item Master Planning Data, Item Master Purchasing Data, Item Master Manufacturing Data (highlighted), Item Master Sales Data, Item Master DRP Planning Data, and Items. A text box on the right contains a list of bullet points explaining the functionality of these links.

- Drill downs to browses "above the line"
- Links to URLs "below the line"
- Can link to desktop maintenance screens
- Can link to other URLs on the web
- Additional call schemes planned (e.g. file:// ftp:// etc.)
- Can pass multiple values

QAD ADM_OVER_350

Browse Drill Down

Browse Drill Down

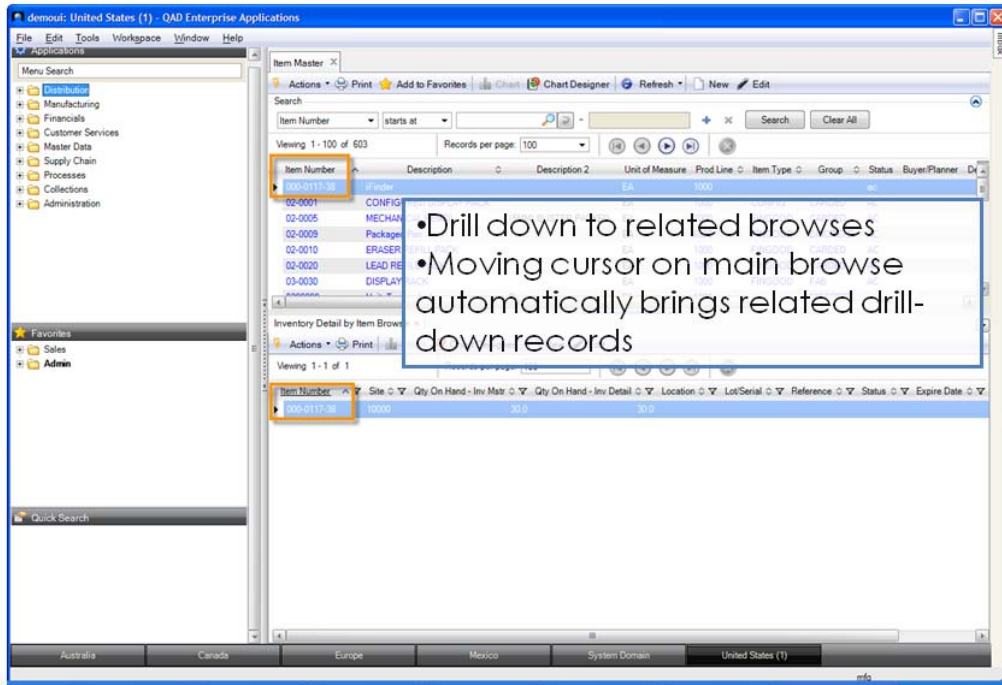

Browse Create and Modify Buttons

Browse Create and Modify Buttons

The screenshot shows the QAD Enterprise Applications interface. On the left is a navigation tree with categories like Distribution, Manufacturing, Financials, Customer Services, Master Data, Supply Chain, Processes, Collections, and Administration. The main area displays an 'Item Master' table with columns for Item Number, Description, Description 2, Unit of Measure, Prod Line, Item Type, Group, Status, and Buyer/Planner. A row for item 000-0117-38 is highlighted. A callout box points to this row with the text: '• Opens appropriate maintenance screen' and '• Create or edit existing records from browse screen'. Below the table, an 'Item Master Maintenance' window is open, showing fields for Item Number (000-0117-38), Description (iFinder), and Unit of Measure (EA). The bottom of the screen features a navigation bar with regional tabs (Australia, Canada, Europe, Mexico, System Domain, United States (2)) and the QAD logo.

Item Number	Description	Description 2	Unit of Measure	Prod Line	Item Type	Group	Status	Buyer/Planner
02-0001	CONFIGURED DISPLAY RACK		EA	1000	CONFIG	CARDED	AC	
02-0005	MECHANICAL PENCIL	(5MM) BLISTER PACKED	EA	1000	FINGOOD	CARDED	AC	
02-0009	Packaged Pen							
02-0010	ERASER REFILL							
02-0020	LEAD REFILL PA							
03-0030	DISPLAY RACK		EA	1000	FINGOOD	FAB	AC	
0300000	Unit, Transaxle		EA	1000	extra	DISCRETE	ac	
0300001	Avle, Integral Ar		EA	1000	extra	DISCRETE	ac	

- Opens appropriate maintenance screen
- Create or edit existing records from browse screen

Item Master Maintenance

Item Number: 000-0117-38
Description: iFinder
Unit of Measure: EA

Item Data

Prod Line: 1000 Item Type: Drawing:
Added: 10/26/2005 Status: ac Revision:
Design Group: Group: Drawing Loc: Size:
Promo Group: Price Break Category:

QAD ADM_OVER_380

Browse Charting

Browse Charting

The screenshot displays the QAD Enterprise Applications interface. The main window is titled 'demoui: United States (3) - QAD Enterprise Applications'. A 'Browse Chart Designer' dialog box is open, showing configuration options for a chart. The X-Axis Label is 'Customer', the X-Variable is 'Sold-To', and the Y-Axis Label is 'Quantity Shipped'. The chart type is set to 'Pie Chart 3D'. A 'Preview Chart' button is visible. Below the designer, a 'Browse Chart' window shows a 3D pie chart titled 'Sales Order Browse'. The chart is divided into six segments with the following percentages: 26.85%, 20.13%, 13.42%, 2.68%, 10.00%, and 26.85%. A legend at the top of the chart window identifies the segments by color and code: 00010002 (blue), 00010002 (green), 00010005 (yellow), 00010005 (orange), 01000000 (dark green), and Others (light blue). A data table is visible in the background, showing columns for quantity, date, and customer information.

Quantity Shipped	Customer	Date
5.0	10/06/1993	
100.0	07/11/1994	
500.0	10/10/1994	
1.0	09/09/2003	
3.0	10/02/2003	
1.0	10/02/2003	
10.0	05/01/2004	
5.0	05/01/2004	
1.0	05/01/2004	

Browse Charting

- Graphic representation of data
- Preview chart
- Types of chart: Column, Bar, Pie, Stacked with 3D option

QAD

ADM_OVER_380

Browse Charting

demoul: United States (1) - QAD Enterprise Applications

File Edit Tools Workspace Window Help

Applications

Sales Order

Sales Order Auto Allocat

Sales Order Auto Credit

Sales Order Auto Credit

Sales Order Batch Shipment Inq

Sales Order Bill Browse

Sales Order Bill Report

Sales Order Browse

Sales Order Confirmation

Sales Order Control

Sales Order Cost Revaluation

Sales Order Credit Inquiry

Sales Order Credit Maintenance

Sales Order Credit Report

Sales Order Gross Margin Report

Sales Order Load

Sales Order Maintenance

Sales Order Manual Allocations

Quantity Shipped

Customer

Australia Canada Europe Mexico System Domain United States (1)

mfq

Toggle between Chart / Grid View

Grid View Chart Designer Refresh New Edit

Viewing 1 - 100 of 2523 Records per page: 100

Sales Order Browse

00010002 00010002 00010005 00010005 01000000 Others

13.42% 2.68% 20.13% 16.78% 20.13%

Hide Titles
Hide Legend
Launch in New Window
Copy to Clipboard

- Hide Titles/Legends
- Rotate and zoom 3D charts
- Search charts
- Launch in New Window

Interactive Charting

Interactive Charting

• Split-screen view of both chart and drill-down browse displayed as chart

• Selecting an item in Inventory Detail browse automatically reflects the changed data in Stock Availability

The screenshot shows a web application interface with a menu on the left, a search bar, and two main data visualization areas. The top area, 'Inventory Detail by Item Browse', features a 3D bar chart with blue bars. The bottom area, 'Stock Availability', features a 3D bar chart with blue and green bars. A text box with a blue border and white background contains the two bullet points. The QAD logo is in the bottom left, and 'ADM_OVER_400' is in the bottom right.

Menu Collections

Menu Collections

demou: United States (1) - QAD Enterprise Applications

Menu Search

- Distribution
- Manufacturing
- Financials
- Customer Services
- Master Data
- Supply Chain
- Processes
- Collections
 - Menu Collections
 - Sales Order Maintenance
 - Sales Order Print
 - Sales Orders by Customer
 - Sales Order Browse
 - Sales Order Shipments

Menu Collection Maintenance

New Save Delete

Name: Sales

Location: Collections-Menu Collections

Items:

- Sales Order Maintenance
- Sales Order Print
- Sales Orders by Customer Report
- Sales Order Browse
- Sales Order Shipments

Define collections of related menu items by dragging and dropping

Quick Search

Australia Canada Europe Mexico System Domain United States (1) mfg

QAD ADM_OVER_410

Browse Collections

Browse Collections

The screenshot shows the QAD .NET UI Administration interface. The 'Browse Collections' window is open, displaying a tree view on the left with 'Browse Collections' selected. The main area shows a 'Sales' collection with a 'Sales Order Maintenance' program selected. A table of sales order records is visible, and a detailed view of a sales order is shown at the bottom right.

Sales Order	Sold-To	Status	Line	Item Number	Unit of Measure	Quantity Ordered	Quantity Open
10001	01000000		1	90-1000	EA	50.0	50.0
10001	01000000		2	90-100	EA	50.0	50.0
10001	01000000		3	90-110	EA	200.0	200.0
10005	1004000		1	color_400	EA	20.0	20.0
10006	00010002		1	icb100-45	EA	100.0	0.0
10006	00010002		2	icb200-45	EA	150.0	0.0

Ship-To:
Colossal Conglomerates LTD
Suite 1000 Colossal Building
Colossal Industrial Park
Evanston
United States of America

- Define collections of related browse and maintenance programs
- For example, Sales Collection – Sales Order browse with a Site browse, Customer browse and Sales Order Maintenance program
- Selecting the sales order will display the associated records in browse and Sales Order Maintenance
- Save under Favorites

Browse Collection Example

Browse Collection Example

The screenshot displays the QAD Enterprise Applications interface. On the left is a navigation tree with categories like 'Applications', 'Menu Search', 'Collections', 'Administration', and 'Favorites'. The main window shows a 'Sales Order' list with columns for Sales Order, Sold-To, Status, Line, Item Number, Unit of Measure, Quantity Ordered, Quantity Open, Due Date, Quantity Shipped, Quote, Ship Type, Purchase Order, and Ship-To. The row for Sales Order 10005 is highlighted. Below the list, the 'Sales Order Maintenance' screen shows details for Order 10005, including Sold-To (Worldwide Supply), Ship-To (Worldwide Supply), address (8000 Central Avenue, Kansas City, MI 48802, United States of America), and order dates (Order Date: 10/22/2002, Required Date: 10/23/2002).

Sales Order	Sold-To	Status	Line	Item Number	Unit of Measure	Quantity Ordered	Quantity Open	Due Date	Quantity Shipped	Quote	Ship Type	Purchase Order	Ship-To
10001	01000000		1	10-10000	EA	5.0	5.0	05/02/1998	0.0				01000000
10001	01000000		2	90-100	EA	50.0	50.0	01/26/1998	0.0				01000000
10001	01000000		3	90-110	EA	200.0	200.0	01/26/1998	0.0				01000000
10005	1004000		1	coltr_400	EA	20.0	20.0	10/23/2002	0.0				1004000
10006	00010002		1	sch100-45	EA	100.0	0.0	10/23/2002	100.0				00010002
10006	00010002		2	sch200-45	EA	150.0	0.0	10/23/2002	150.0				00010002
10007	00010005		1	sch100-45	EA	200.0	0.0	10/23/2002	200.0				00010005

Order: 10005 Sold-To: 1004000 Bill To: 1004000 Ship-To: 1004000

Sold-To: Worldwide Supply Ship-To: Worldwide Supply

8000 Central Avenue 8000 Central Avenue
Kansas City Kansas City MI 48802 MI 48802
United States of America United States of America

Order Date: 10/22/2002 Line Pricing: Confirmed: 10/22/2002
Required Date: 10/23/2002 Manual Currency: USD Language: US



Browse Collection Example

The screenshot displays the QAD Enterprise Applications interface. The main window is titled 'Sales' and shows a 'Sales Order' table. The table has the following data:

Sales Order	Sold-To	Status	Line	Item Number	Unit of Measure	Quantity Ordered	Quantity Open	Due Date	Quantity Shipped	Quote	Ship Type	Purchase Order	Ship-To
10001	01000000		1	10-10000	EA	5.0	5.0	05/02/1998	0.0			01000000	10
10001	01000000		2	90-100	EA	50.0	50.0	01/26/1998	0.0			01000000	10
10001	01000000		3	90-110	EA	200.0	200.0	01/26/1998	0.0			01000000	10
10006	00010000		1	rcb100-45	EA	20.0	20.0	10/23/2002	0.0			00010000	10
10006	00010000		1	rcb100-45	EA	100.0	0.0	10/23/2002	100.0			00010000	10
10006	00010002		2	rcb200-45	EA	150.0	0.0	10/23/2002	150.0			00010002	10
10007	00010005		1	rcb100-45	EA	200.0	0.0	10/23/2002	200.0			00010005	10

Below the main table, there is a secondary window titled 'Customer' showing a single record:

Customer	Worldwide Supply	P/L	Country	Salesperson	Type	Site	Language	Remarks	Time Zone
100000			United States of America	RLC, INC.	0601	10000	US		PST/PDT

The interface includes a navigation pane on the left with categories like 'Collections', 'Administration', and 'Favorites'. The status bar at the bottom shows 'United States (1)' and 'mfg'.

Multiple Views

Multiple Views

The screenshot shows the 'Item Browse' window in QAD Enterprise Applications. The window title is 'demo1: United States (1) - QAD Enterprise Applications'. The interface includes a menu bar (File, Edit, Tools, Workspace, Window, Help), a toolbar with options like 'Actions', 'Print', 'Add to Favorites', 'Chart', 'Chart Designer', 'Refresh', 'New', and 'Edit'. A search bar is located above the table. The table displays a list of items with columns for 'Item Number', 'Description', 'Description 2', and 'Unit of'. Two callout boxes with blue borders provide instructions: 'Drag the border for multiple horizontal views' points to the right edge of the table, and 'Drag the border for multiple vertical views' points to the bottom edge of the table. The bottom of the window features a status bar with regional tabs (Australia, Canada, Europe, Mexico, System Domain, United States (1)) and a user name 'mfg'.

Item Number	Description	Description 2	Unit of
02-0001	CONFIGURED DISPLAY RACK		EA
02-0005	MECHANICAL PENCIL (SMM) BLISTER PACKED		EA
02-0009	Packaged Pen		EA
02-0010	ERASER REFILL PACK		EA
02-0020	LEAD REFILL PACK		EA
03-0030	DISPLAY RACK		EA
0300000	Unit, Transable Aux Drive		EA
0300001	Axle, Integral Arm Steel		EA
0300002	Filter, Air		EA
0300003	Filter, Coolant		EA
04-0009	Assembled Pen		EA
05-005	Barrel		EA
05-0079	Ink Cart, 50 ML		EA
05-0095	Pen Cap		EA
05-0579	Prototype Ink Cart, HQ		EA
09-0039	Printed Card Pen		EA
0924219-0000	white 2MSCB 40#		LB
0924743-0000	white 035 429CB 40#		LB
0995689-0002	U-Bolt Clamp		EA
0990711-0007	U-Bolt Clip		EA
1-20001	Final Item 1	KB Item	EA



Multiple Views

The screenshot displays the QAD Enterprise Applications interface with a list of items. Two callout boxes are overlaid on the interface:

- A box at the top right says: "Drag the border for multiple horizontal views" with an arrow pointing to the right edge of the list area.
- A box at the bottom left says: "Drag the border for multiple vertical views" with an arrow pointing to the bottom edge of the list area.

Item Number	Description	Description 2	Unit of Measure
000-0117-38	Finder		EA
02-0001	CONFIGURED DISPLAY RACK		EA
02-0005	MECHANICAL PENCIL (5MM) BLISTER PACKED		EA
02-0009	Packaged Pen		EA
02-0010	ERASER REFILL PACK		EA
02-0020	LEAD REFILL PACK		EA
03-0030	DISPLAY RACK		EA
0300000	Unit, Trans axle Aux	Drive	EA
0300001	Axle, Integral Arm Steel		EA
0300002	Filter, Air		EA
0300003	Filter, Coolant		EA
04-0009	Assembled Pen		EA
05-005	Barrel		EA
05-0079	Ink Cart, 50 ML		EA
05-0095	Pen Cap		EA
06-0676	Ballpoint Ink, Blue, 1/8"		EA



External Files as Favorites

External Files as Favorites

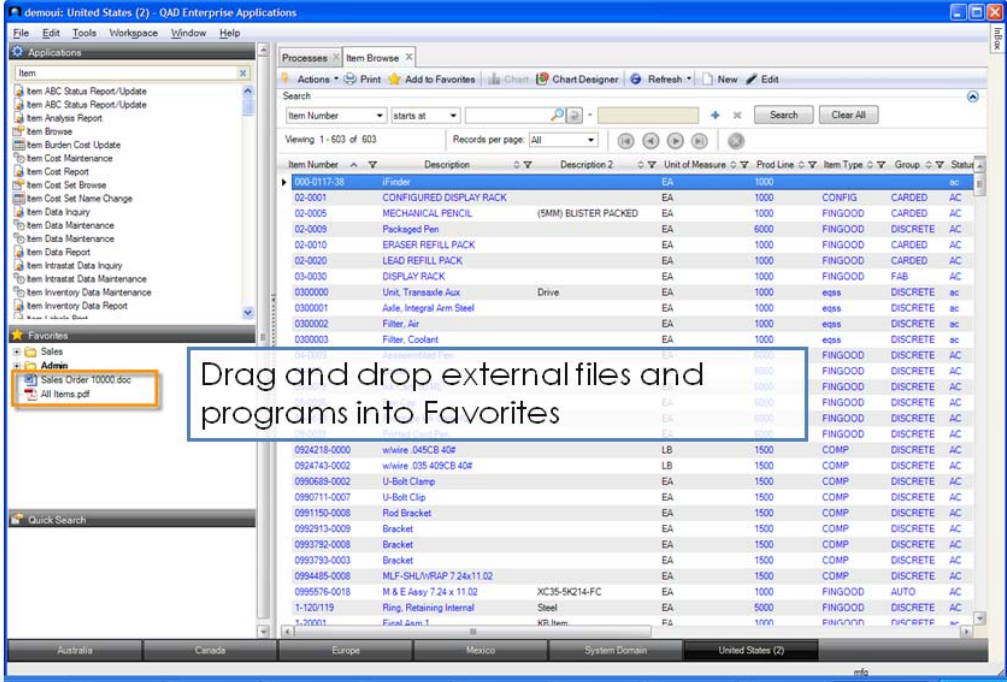

Connect to Other Applications

Connect To Other Applications

Connect to other applications: define a menu item to open QAD BI Dashboard

QAD
Our Passion. Your Advantage.

Pam's Production Manager Dashboard

Item Grp
■ Adhesive
■ Blank
■ BSP
■ Core
■ Drains
■ Other

Past Due Sales Orders

Daily Revenue (USD)

	Adhesive	Blank	BSP	Core	Drains	Other
Lines Early	0	0	0	0	0	0
Lines Same	4,974	30	1,712	143,702	10,258	18,018
Lines Late	3,804	10	717	67,256	4,353	6,006
Lines 1 day late	916	3	201	19,372	1,122	1,056
Lines 2 days late	922	5	147	18,491	1,026	1,411
Lines 3 days late						

mfg



Exercises

Exercises

- Create a new product structure using Product Structure Maintenance
- Add menu options to your Favorites
- Open Sales Order Browse and add filters, create a chart, group the browse by Sales Order, organize it in multiple views (vertical and horizontal)
- Create a new Menu Collection, choosing any options that relate with each other
- Create a new Browse Collection with
 - Site Browse
 - Customer Browse
 - Sales Order Maintenance

Chapter 2

Terminology

Chapter Objectives

Chapter Objectives

- The objective of this chapter is to describe terminology you need to know to understand the QAD .NET UI

Benefits

Benefits

- You will be familiar with the terminology used in QAD .NET UI administration

Training Flow

Training Flow



- Overview
- **Terminology**
- Components
- Administration Tasks
- Multiple Systems
- Performance Tuning
- Troubleshooting
- Customizing Browsers
- Menu and Browse Collections
- Process Maps
- Configurable Screens

Overview

Overview

- Network Terminology
- Web Terminology
- Java Terminology
- Tomcat Terminology
- .NET Terminology

Network Terminology

Network Terminology

- Intranet: A private network inside a company
- Internet: A system of linked networks that are worldwide in scope
- Extranet: A network that allows a company to share information with other businesses and customers

Network Terminology

- LAN: Local Area Network. A network of computers that span a relatively small area
- WAN: Wide Area Network. A network that spans a larger area and comprised of two or more LANs
- TCP/IP: Transmission Control Protocol / Internet Protocol
- HTTP: Hypertext Transmission Protocol

Web Terminology

Web Terminology

- HTML: Hypertext Markup Language
- URL: Uniform Resource Locator
- HTML Documents: ASCII files containing HTML that the Web server sends to the browser
- CGI: Common Gateway Interface

JAVA Terminology

Java Terminology

- JAR File: Java Archive File. A zip file that contains an optional META-INF directory
- JVM: Java Virtual Machine. Enables cross-platform delivery
- JDK/JSDK: Java Development Kit (required by Tomcat)

Tomcat Terminology

Tomcat Terminology

- Servlet: Simple, consistent mechanism for extending the functionality of a Web Server
- JSP: JavaServer Pages; technology to rapidly develop and easily maintain information-rich, dynamic Web pages
- XML: eXtensible Markup Language
- XSLT: Transforms XML to another format and allows manipulation of Elements, Attributes and Data

.NET Terminology

.NET Terminology

- .NET: Microsoft software for connecting information, people, systems, and devices. .NET provides XML-based interoperability and is being incorporated across Microsoft clients, servers, services, and tools.
- .NET Framework: An integral Windows component that enables building and running the next generation of software applications and Web services.
- ADO.NET
 - Key for integrating .NET with Progress
 - A set of classes used to wrap data and data services
 - XML Web Services
 - .NET Remoting
 - Passes data back and forth to OpenEdge AppServer
 - In memory database

.NET Terminology

- ProDataSet
 - An OpenEdge in-memory data store
 - Maps directly to an ADO.NET DataSet allowing us to:
 - Design a .NET interface in terms of .NET DataSets
 - Pass data back and forth to OpenEdge AppServer

Chapter 3

Components

Chapter Objectives

Chapter Objectives

- The objective of this chapter is to describe the QAD .NET UI components and architecture

Benefits

Benefits

- You will be familiar with the components used in QAD .NET UI architecture and installation

Training Flow

Training Flow



- Overview
- Terminology
- **Components**
- Administration Tasks
- Multiple Systems
- Performance Tuning
- Troubleshooting
- Customizing Browsers
- Menu and Browse Collections
- Process Maps
- Configurable Screens

Overview

Overview

- .NET UI Technology Overview
- .NET UI Architecture
 - Progress WebSpeed
 - Progress AppServer
 - Tomcat
 - Connection Manager
 - Telnet Server
 - .NET UI Client

NET UI Architecture

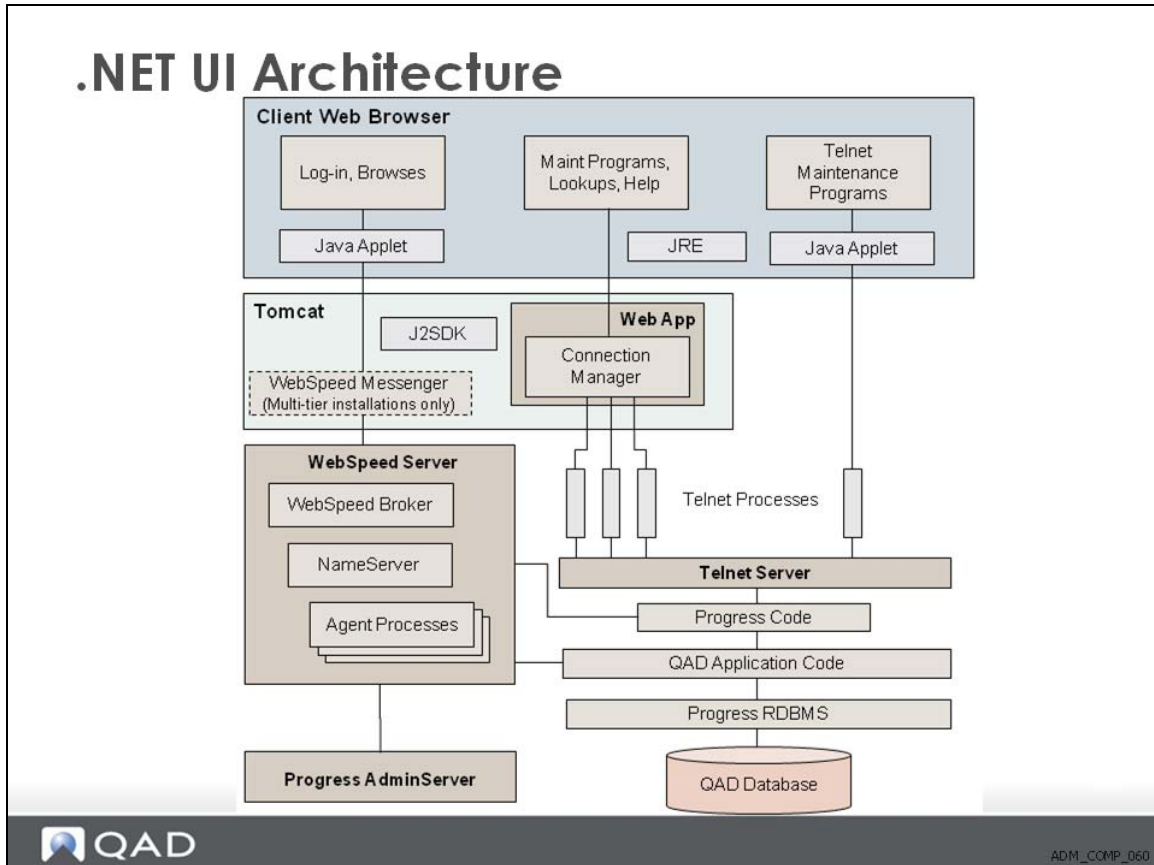

What Is WebSpeed?

What is WebSpeed?

- WebSpeed is a Progress development and deployment environment that enables users to build robust, data-driven Internet Transaction Programs (ITP) for the intranet or Internet
- Enables you to create Web Objects (application modules) that map data to and from static HTML documents using the WebSpeed Workshop and WebSpeed 4GL
- Enables you to deploy your HTML pages and Web Objects to a run-time environment using the WebSpeed Transaction Server

WebSpeed Architecture

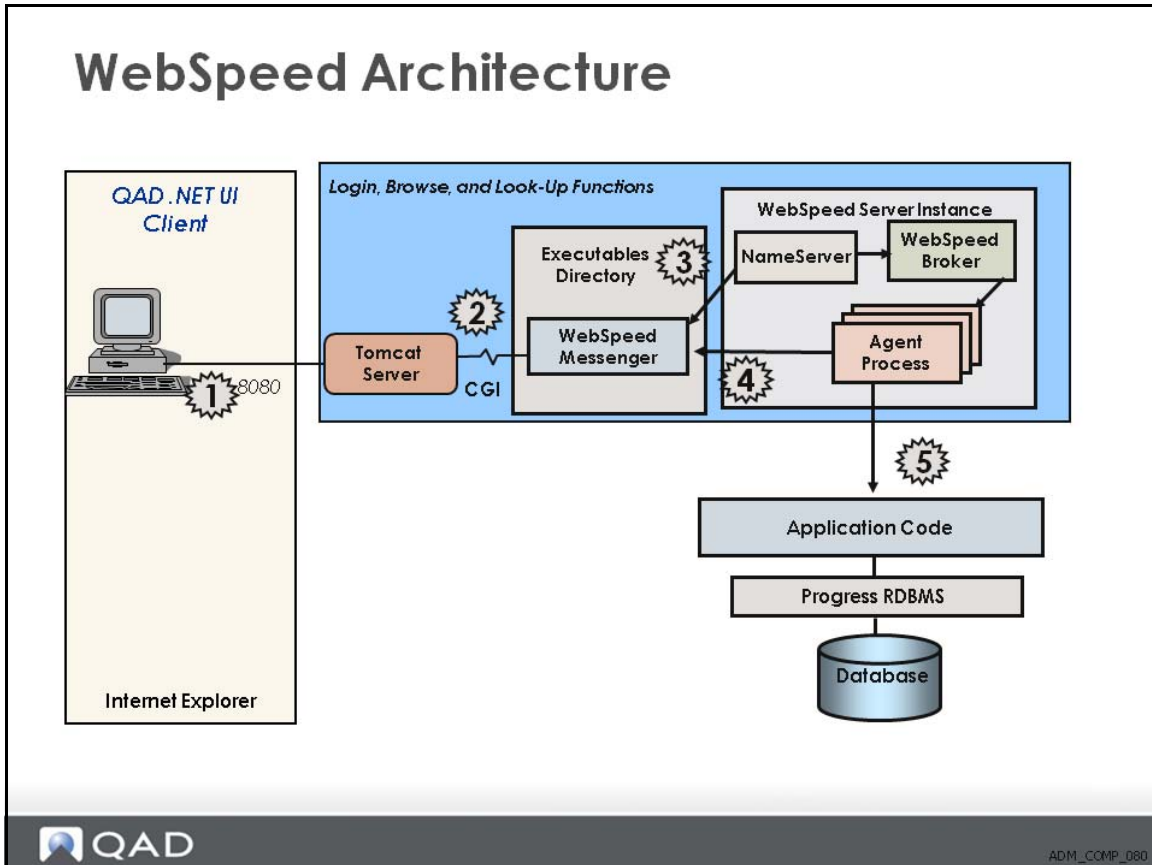

WebSpeed Architecture 1

WebSpeed Architecture

- Connection 1
 - Network Connection between the browser and the Tomcat server. Default server port is 8080
 - Tomcat server and WebSpeed messenger must be on the same machine
 - Tomcat server communicates with the WebSpeed messenger

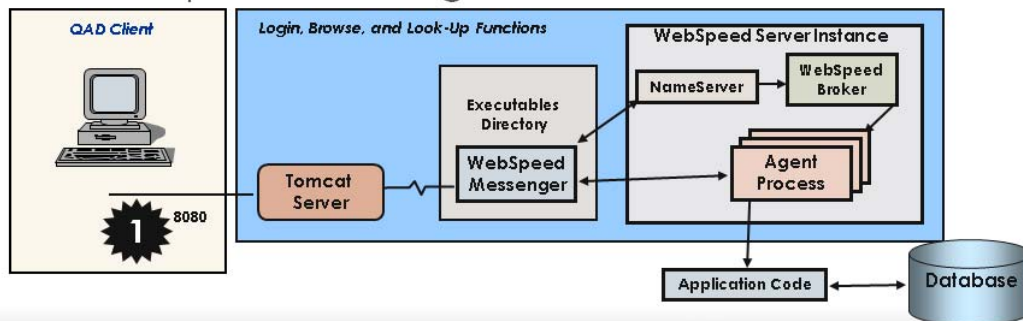

WebSpeed Architecture 2

WebSpeed Architecture

- Connection 2
 - Tomcat server connection to the WebSpeed messenger
 - Uses script programs stored on the Tomcat server to communicate with the messenger
 - Messenger is a PROGRESS .exe file that takes a PROGRESS Web Object procedure (.w) as input and sends back an HTML page as output

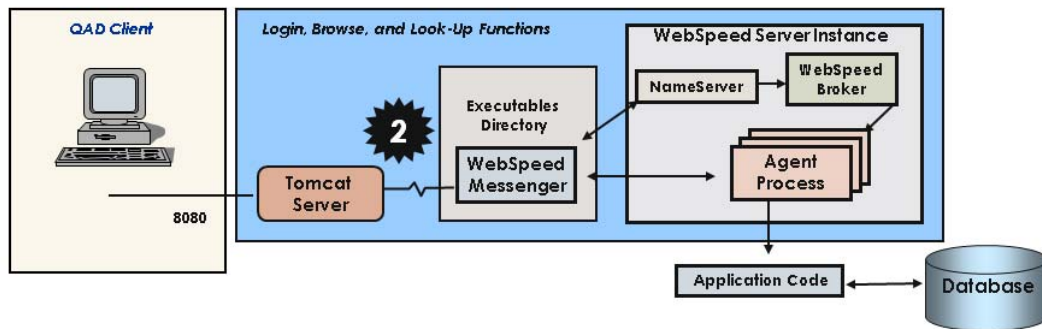

WebSpeed Architecture 2

WebSpeed Architecture

- CGI Messenger executables
 - Uses script programs stored on the Tomcat server to communicate with the messenger
 - cgiip.exe (NT) cgiip (UNIX)
 - The messenger asks the broker if there are agents available to run a web object, then passes the web object to the agent for processing

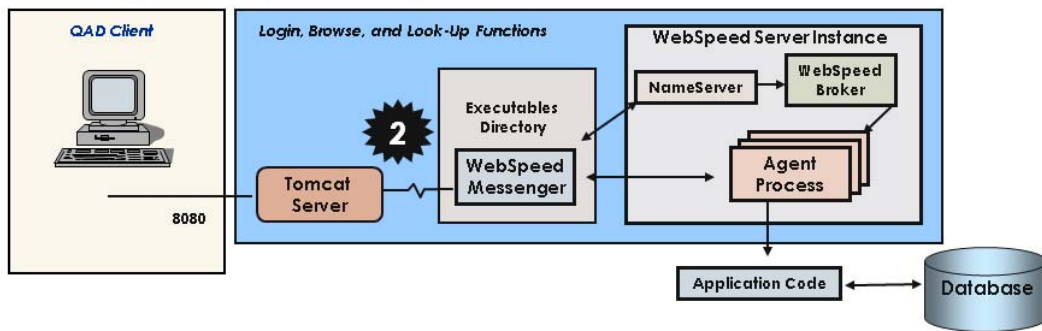

WebSpeed Architecture 2

WebSpeed Architecture

- After processing, the agent returns its HTML output to the messenger for transfer back to the web server and finally to the browser

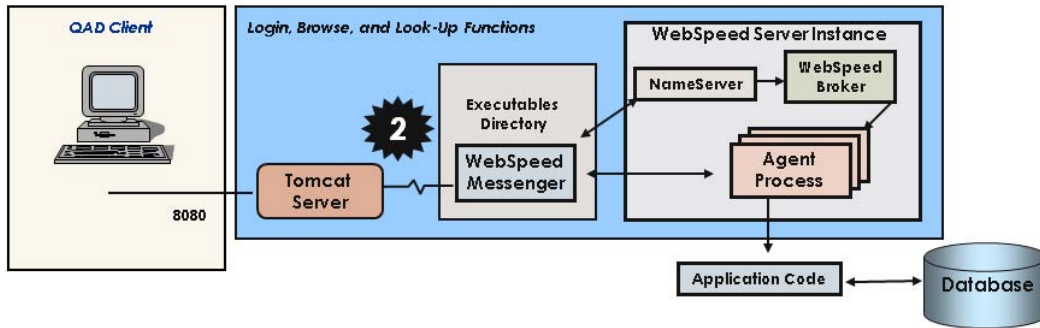

WebSpeed Architecture 3

WebSpeed Architecture

- Connection 3
 - Network connection between the messenger and the transaction broker
 - Defined by the hostname and port defined in the `ubroker.properties` file

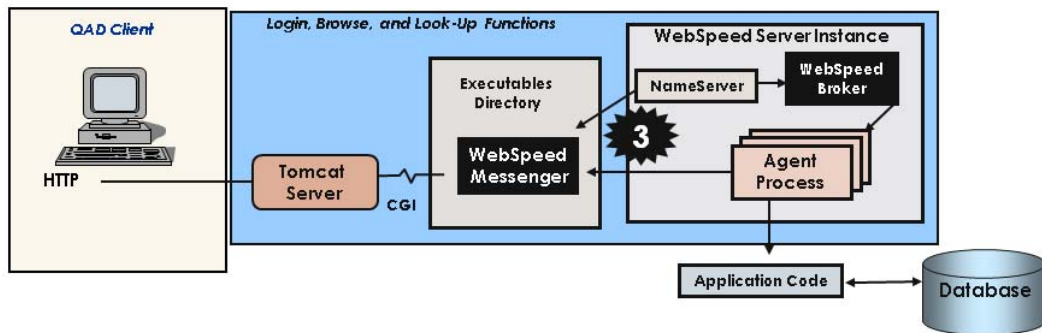

WebSpeed Architecture 3

WebSpeed Architecture

- WebSpeed Transaction Broker is responsible for:
 - Receiving requests from the messenger on availability of an agent to service the Web object
 - Replying to the messenger with the ID and port of the available agent
 - Spawning a new agent if none available and not at the limit

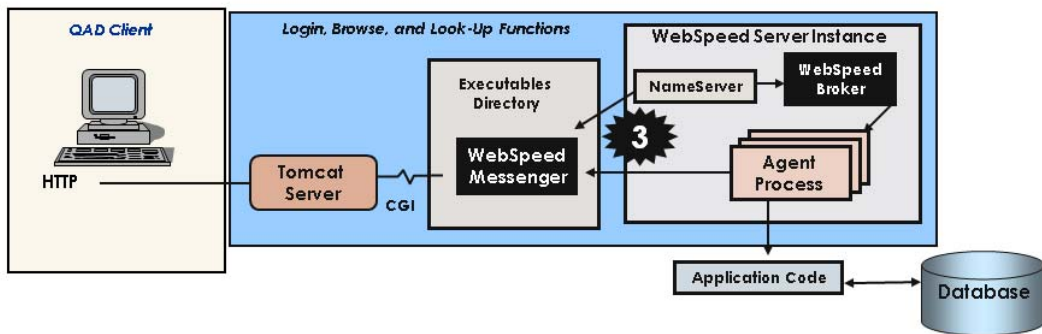

WebSpeed Architecture 3

WebSpeed Architecture

- The WebSpeed broker will assign an agent
 - If at the limit, sends message to messenger that no agents are available
 - Provides the status and states of running agents
 - STARTING, AVAILABLE, LOCKED, BUSY

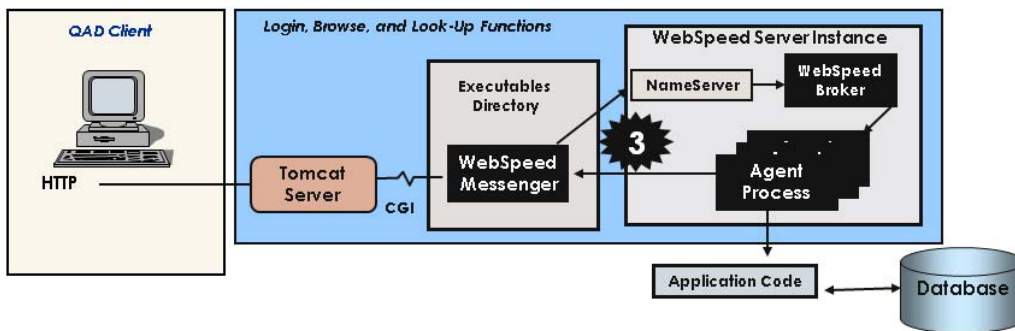

WebSpeed Architecture 4

WebSpeed Architecture

- Connection 4:
 - Network connection between the WebSpeed transaction agents and Web server
 - Defined by the hostname and port defined in the `ubroker.properties` file

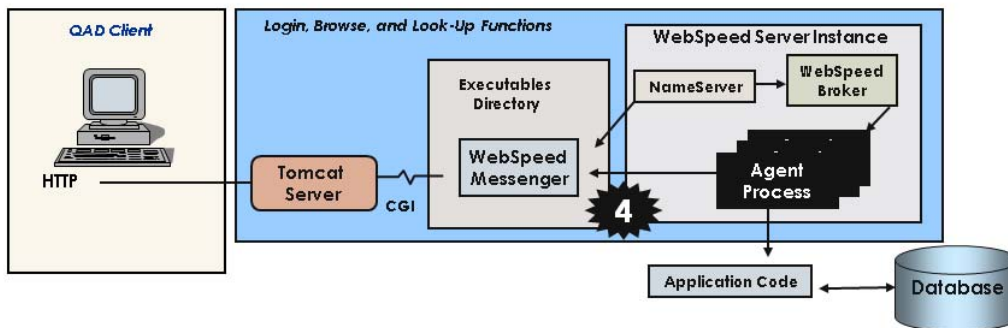

WebSpeed Architecture 4

WebSpeed Architecture

- WebSpeed Transaction Agent:
 - A Progress client (_progres) with modifications to work with WebSpeed
 - Agents accept requests from the messenger in the form of a URL, parse the URL for the name of the web object to execute, and then run it
 - Passes output back to the messenger

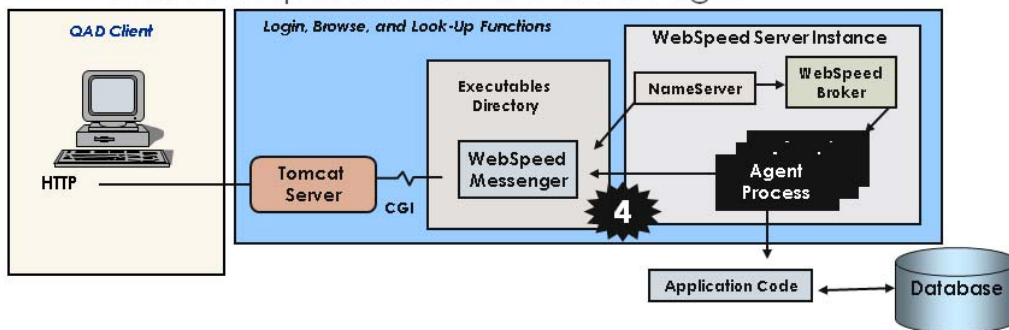

WebSpeed Architecture 5

WebSpeed Architecture

- Connection 5:
 - Connection between agents and the database
 - The WebSpeed Agents can connect to the databases in either Client/Server or shared memory mode

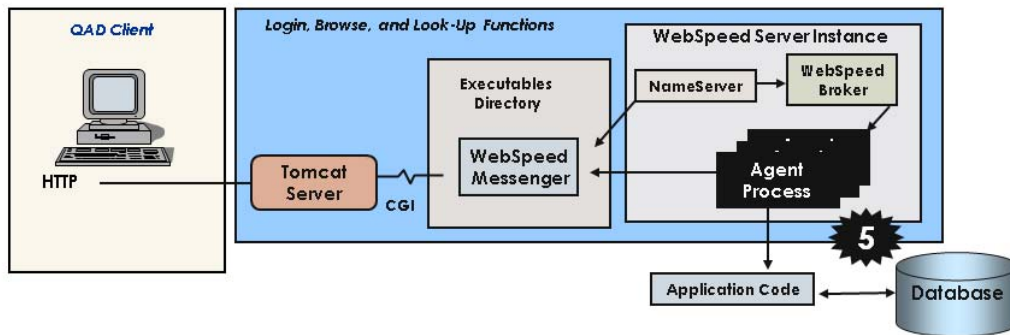

Progress AppServer

Progress AppServer

- Executes OpenEdge 4GL Procedures that can be called by Progress, Java and .NET

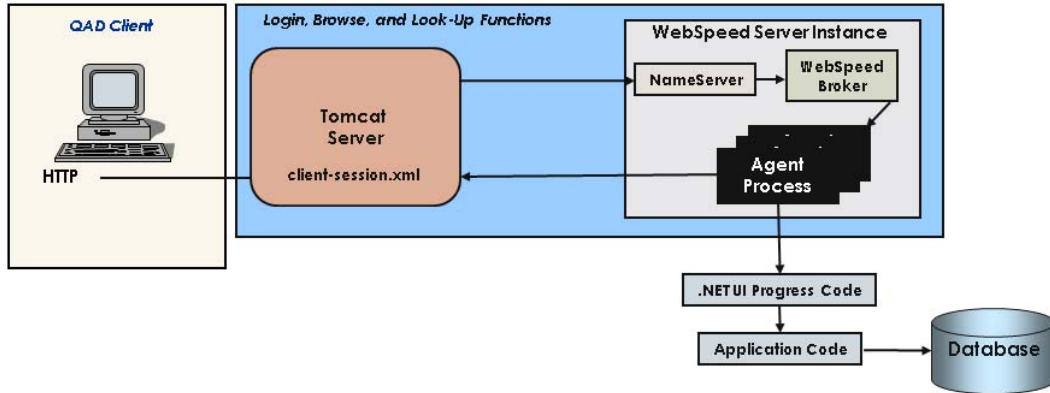

Tomcat J2EE Application Server

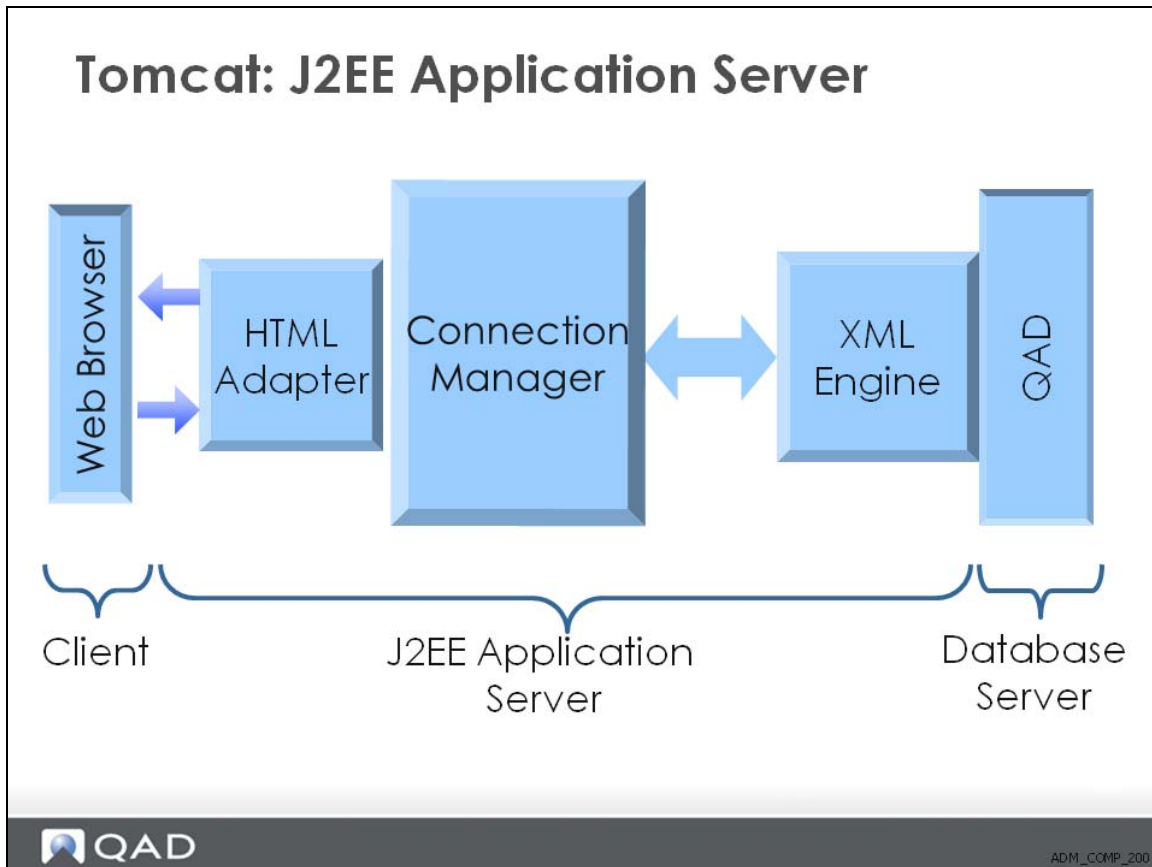

Tomcat Overview

Tomcat Overview

- Java-based Web application container
- Runs servlet in JSP
- Tomcat 5.5.x and 6.0.x
- If upgrading and using 5.5.x, you do not need to upgrade to 6.0.x.

Tomcat Directories - Key Subdirectories

Tomcat Directories

- Key subdirectories
 - /bin – administration scripts
 - startup.sh
 - shutdown.sh
 - setenv.sh
 - /logs – log files directory
 - catalina.out
 - tomcat.pid
 - /conf – configuration files directory
 - server.xml
 - tomcat-users.xml
 - /webapps – web applications directory
 - Location of .NET UI directories and files

Tomcat Directories - Key .NET UI Directories

Tomcat Directories

- Key .NET UI directories
 - Configuration files
 - /webapps/qadhome/<env_name>/configurations
 - Client session configuration file
 - /webapps/qadhome/<env_name>/configurations/client-session.xml
 - Process Maps
 - /webapps/<env_name> /WEB-INF/pronav
 - Configurable Screens
 - <qad_install_dir>/<netui_progress_dir>/com/mfgpro/configxml/qaddb
 - Metrics, Favorites, Collections
 - /webapps/qadhome/configurations/<env_name> /storage

Tomcat Directories - Attachments

Tomcat Directories

- Key .NET UI directories: Attachments
 - Attachments default location:
 - `/webapps/qadhome/configurations/<env_name>/storage/attachments`
 - Attachments single WebDAV location:
 - Specify in `client-session.xml`:
 - `<WebDAVRoot>ServerURL
/webdav/attachments</WebDAVRoot>`

Tomcat Directories - Key .NET UI Files

Tomcat Directories

- Key .NET UI files
 - /webapps/<.NET UI Install>
 - /WEB-INF
 - /conf -- configuration files for .NET UI components
 - /cgi -- WebSpeed Messenger and other executables
 - /log -- log files for .NET UI
 - /WEB-INF/conf
 - connectionManagerConfig.xml
 - Stores configuration values for the connection manager
 - Edit via the Connection Manager
 - process-config.xml
 - Stores values for the Process Editor

Using Tomcat

Using Tomcat

- Set JAVA_HOME environment variable
- Startup Tomcat (`startup.sh`)
- Verify Tomcat Server is up
(`http://hostname:8080`)
- Shutdown Tomcat (`shutdown.sh`) as needed
- See `catalina.out` for error messages

Tomcat Engine Architecture

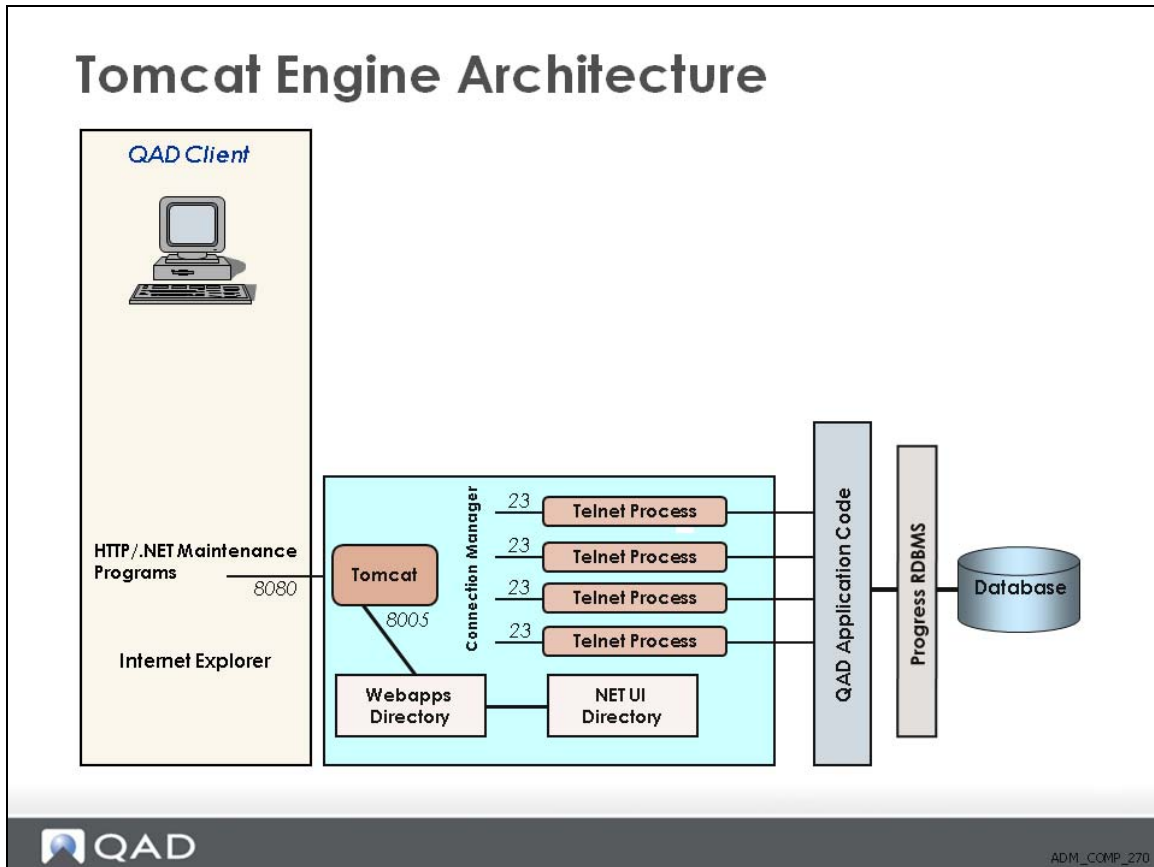

Connection Manager

Connection Manager

- Use to update configuration settings
- View a log file of Connection Manager actions
- Monitor connections in the connections pool
- Monitor users and close user sessions
- Configure Connection Manager before you start a .NET UI client session

Connection Manager

- Manage pool of Telnet connections
- Functions
- Connections
- Users

The screenshot shows the 'Connection Manager' window. On the left is a sidebar with sections: 'Functions' (Close Connection Manager, Restart Connection Manager, Reset failed init count, Delete HTML cache, Message of the day, Update configuration settings), 'Connections' (All, Busy, Idle, Initializing), and 'Users' (Refresh). The main area is titled 'Connection Manager - Default/Desktop' and shows a status bar: 'Fri Jun 18 07:48:54 PDT 2010' and 'All: 2 Busy: 0 Idle: 2 Initializing: 0'. Below this is a table with columns: Status, ID, Process ID, User ID, Device, User IP, Maximum Connections, Program, User Connected Time, and Close. The table contains two rows of 'Idle' connections and a 'Total' row. A 'Refresh' button and a 'Close All' button are located at the bottom right of the table area.

Status	ID	Process ID	User ID	Device	User IP	Maximum Connections	Program	User Connected Time	Close
Idle	904	0	null		null	0	null		Close
Idle	905	0	null		null	0	null		Close
Total	2								Refresh Close All

Configuration Settings

Configuration Settings

- Update as necessary
- Host: The machine name or IP address of the telnet server
- Port: The port number for the telnet server. Usually set to 23

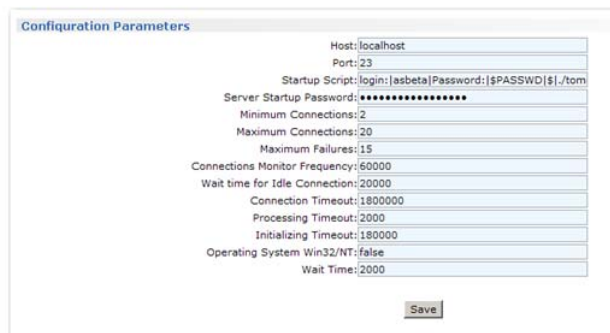

The screenshot shows a dialog box titled "Configuration Parameters" with the following fields and values:

Host:	localhost
Port:	23
Startup Script:	login:[asbeta]Password:[\$PASSWD]\$.tom
Server Startup Password:	*****
Minimum Connections:	2
Maximum Connections:	20
Maximum Failures:	15
Connections Monitor Frequency:	60000
Wait time for Idle Connection:	20000
Connection Timeout:	1800000
Processing Timeout:	2000
Initializing Timeout:	180000
Operating System Win32/NT:	false
Wait Time:	2000

A "Save" button is located at the bottom right of the dialog box.

Monitor Connections and Users

Monitor Connections and Users

- Displays connection status
- Click Refresh to update
- View currently logged in users
- Click the user ID to view user information
- Click Close to close a user session

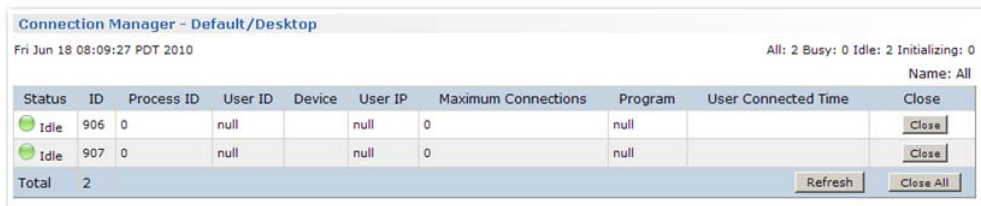

The screenshot shows a window titled "Connection Manager - Default/Desktop". At the top right, it displays "All: 2 Busy: 0 Idle: 2 Initializing: 0". Below this is a search field with "Name: All". The main area contains a table with the following columns: Status, ID, Process ID, User ID, Device, User IP, Maximum Connections, Program, User Connected Time, and Close. There are two rows of data, both with a green "Idle" status icon. The first row has ID 906, Process ID 0, User ID null, Device null, User IP null, Maximum Connections 0, Program null, and User Connected Time null. The second row has ID 907, Process ID 0, User ID null, Device null, User IP null, Maximum Connections 0, Program null, and User Connected Time null. At the bottom left of the table, it says "Total 2". At the bottom right, there are "Refresh" and "Close All" buttons.

Status	ID	Process ID	User ID	Device	User IP	Maximum Connections	Program	User Connected Time	Close
Idle	906	0	null		null	0	null		Close
Idle	907	0	null		null	0	null		Close
Total 2									Refresh Close All

.NET UI Client

.NET UI Client

- Runs in the Microsoft .NET framework
- Server components are installed during the .NET UI install
- Brief automated installation on client

Exercise

Exercise

- Verify that all .NET UI components are working:
 - All databases are started
 - Progress OpenEdge Admin Server
 - Progress OpenEdge NameServer
 - Progress OpenEdge WebSpeed Broker
 - Progress OpenEdge AppServers (Financials and UI)
 - Tomcat Server (idle session)
- Install QAD .NET UI Client

Chapter 4

QAD .NET UI Administration

Chapter Objectives

Chapter Objectives

- The objective of this chapter is to describe different administration features and functions

Benefits

Benefits

- You will have an overview of release and service pack installations, be able to edit the `client-session.xml` file, and to identify and use different session monitors and logs

Training Flow

Training Flow



- Overview
- Terminology
- Components
- **Administration Tasks**
- Multiple Systems
- Performance Tuning
- Troubleshooting
- Customizing Browsers
- Menu and Browse Collections
- Process Maps
- Configurable Screens

Overview

Overview

- Installation of New Release or Service Pack
- Client Session Configuration
- System-Wide Logging Settings
- Configuration Storage Directories
- Menu Extension Configuration
- Session Configuration
- Session Monitoring
- Connection Manager
- Heartbeat Monitor
- User Count Log

Overview (continued)

- Adding Custom Menus
- Using Attachment Maintenance
- Active Directory Authentication
- Messaging and Workflow Inbox
- Adding Custom Links
- Adding Transaction Comments
- Embedded Telnet Screens
- Recording Program Actions

Installation

Installation

- Installation of new release
 - Review Release Notes and Errata
 - Clear Tomcat cache
 - .NET UI client automatically checks for new version
- Installation of a service pack
 - May overwrite newer MFGUTIL files
 - Re-install may be needed to place back updated MFGUTIL files

Client Session Configuration

Client Session Configuration

- Client Session Configuration File:
 - `client-session.xml`
 - Located on the server in
`/webapps/qadhome/configurations/
<env_name>/client-session.xml`
 - Contains configuration for NameServer,
AppServer and WebSpeed broker names and
ports
 - Progress OpenEdge DC (Direct Connect)
parameter for the AppServer should be set up

Client Session Configuration

- Client Session Configuration File:
 - client-session.xml

```
<?xml version="1.0" encoding="utf-8" ?>
<Configuration>
  <ConnectionProtocol>AppServer</ConnectionProtocol>
  <ConnectionSecureProtocol>AppServer</ConnectionSecureProtocol>
  <ConnectionHost>qaddemo.qad.com</ConnectionHost>
  <ConnectionPort>5162</ConnectionPort>
  <ConnectionService>qaddemo_AS</ConnectionService>
  <ConnectionSecureService>qaddemo_AS</ConnectionSecureService>
  <ConnectionSecureHost>qaddemo.qad.com</ConnectionSecureHost>
  <ConnectionSecurePort>5162</ConnectionSecurePort>
  <DesktopProtocol>http</DesktopProtocol>
  <DesktopHost>qaddemo.qad.com</DesktopHost>
  <DesktopPort>8080</DesktopPort>
  <DesktopService>qaddemo</DesktopService>
  <DesktopAPI>shell.jsp</DesktopAPI>
  <DesktopAsWebBrowser>>false</DesktopAsWebBrowser>
  <WebSpeedService>qaddemo_WS</WebSpeedService>
  <WebSpeedPath>cgi-bin/wspd_cgi.ksh/WService</WebSpeedPath>
  <WebSpeedProgram>com/qad/desktop/interface/wsep1.p</WebSpeedProgram>
```

Client Session Configuration

- Setting Browse Record Threshold in `client-session.xml`

```
<MaximumBrowseRecordsToCount>50000</MaximumBrowseRecordsToCount>  
<MaximumBrowseRecordsToDownload>50000</MaximumBrowseRecordsToDownload>  
<BrowseRecordsForPrintWarning>10000</BrowseRecordsForPrintWarning>  
<BrowseRecordsForExcelWarning>10000</BrowseRecordsForExcelWarning>  
<ChartElementsForChartWarning>100</ChartElementsForChartWarning>
```

System-Wide Logging Settings

System-Wide Logging Settings

- Applying system-wide settings
 - Set in `./webapps/qadhome/configurations/default/client-bootstrap.xml`
 - Examples: Log level, log file location
- Increasing the logging level increases the log file size
- Use only to debug problems for short periods of time

Configuration Storage Directories

Configuration Storage Directories

- By default, attachments stored in `/webapps/qadhome/configurations/<env_name>/storage/attachments`
- Subdirectories organize attachments by domain, program, type, and field
- Each directory includes an underscore (`_`) at the end to account for the possibility of using a blank

Configuration Storage Directories

- Browse collections are stored in `/webapps/qadhome/configurations/<env_name>/storage/browse-collections`. Each is assigned a unique ID by the system.
- Menu collections are stored in `/webapps/qadhome/configurations/<env_name>/storage/menu-collections`. Each is assigned a unique ID by the system.
- Favorites are stored in `/webapps/qadhome/configurations/<env_name>/storage/user-data` in subdirectories based on user ID and domain

Configuration Storage Directories

- Browse collections are stored in `/webapps/qadhome/configurations/<env_name>/storage/browse-collections`. Each is assigned a unique ID by the system.
- Menu collections are stored in `/webapps/qadhome/configurations/<env_name>/storage/menu-collections`. Each is assigned a unique ID by the system.
- Favorites are stored in `/webapps/qadhome/configurations/<env_name>/storage/user-data` in subdirectories based on user ID and domain

Menu Extension Configuration

Menu Extension Configuration

- The menu extension configuration file defines menus added to the QAD .NET UI outside of standard menu items.
- By default, file is located in
`/webapps/qadhome/configurations/default/menus/plugin-menu.xml`
- You can define them for each environment by placing them in appropriate directories under the `/configurations` directory:
`/webapps/qadhome/configurations/<env_name>/menus/plugin-menu.xml`

Menu Extension Configuration

- To add Microsoft Excel:

```
<ShellMenuItem key="apps.excel" label="Word"
  image=".xls">
  <Command type="QAD.Commands.ProcessCommand">
    <Property name="StartInfo.FileName"
value="Excel.exe"/>
  </Command>
</ShellMenuItem>
```

- To add Microsoft Internet Explorer:

```
<ShellMenuItem key="apps.iexplore"
  label="WebBrowser" image=".html">
  <Command type="QAD.Commands.ProcessCommand">
    <Property name="StartInfo.FileName"
value="about:blank"/>
  </Command>
</ShellMenuItem>
```

Session Configuration

Session Configuration

- Set session configuration
 - Can set maximum number of forms each user can open
 - Affects maintenance, inquiries, reports, and embedded telnet screens
 - Browsers, Financials, Workbenches, and Product Structure Maintenance are driven by the OE AppServers
 - Setting it too high can impact performance
 - Set in User Option Telnet Maintenance

Session Configuration

User Option Telnet Maintenance

Go To Actions Copy Print Preview

User ID: *

Telnet Options

Host:	cdl49.qad.com	Script Timeout:	240
Host O/S:	UNIX	Port:	23
Image:		Idle Timeout:	240

Script Lines

Sequence: 1

Script Lines Data

Script Pattern: login:

Script Value: netui

Script Status:

Telnet Connections

Maximum:

Min Telnet Connect:

Delete Back Next

Session Monitoring

Session Monitoring

- Session Master Maintenance
 - No maintenance done in this screen
 - Can be used to delete defunct users
 - Specifies a system-generated session ID
- Connection Manager
 - Monitor which users are accessing system/programs
 - View status of connection pools
- Heartbeat Monitor
 - Configure load balancer device or create script that monitors the Connection Manager through heartbeat pages
- User Count Log File
 - Logs user, program executed, and time of execution
 - Located in /webapps/<qadui.cfg>/WEB-INF/logs/usercount.log

Session Master Maintenance

Session Master Maintenance

File Edit Tools Workspace Window Help

Applications

Menu Search

- Language Detail Maintenance
- Report Translation Maintenance
- Menu System Menu
- Message Menu
- Browse Menu
- User Function Browse
- User-Defined Object Menu
- Field Help Menu
- User Option Telnet Maintenance
- User Option Report
- Configurable Screens Report
- Label Menu
- Customization Export
- Customization Delete
- E-Mail Definition Maintenance
- Report Setup Menu
- Session Master Maintenance**

Session ID: 020020w6ESjT&rvHaKeUlyRjLlnZi41nX0Yp482pl8cgHZolvl0

User ID: mfg

User Name: General User

Session Master

Client IP Address: 167.3.9.60	Security Profile:
Session Timeout: 600 Mi	Idle Time: 0.07 Min
Active Web: 0	Active Telnet: 2
Number of Records: 0	Menu Substitution: <input type="checkbox"/>

Session Context Detail

Context ID: 1	Domain: Domain1
GI Entity: 1000	Current Entity: 1000
	Base Currency: USD
	Database: newyork

Delete Back Next

QAD ADM_ADM_190

Connection Manager

Connection Manager

The screenshot displays the QAD Connection Manager application. The main window is titled 'Connection Manager - Default/Desktop' and shows a table of active connections. The table has columns for Status, ID, Process ID, User ID, Device, User IP, Maximum Connections, Program, User Connected Time, and a Close button. Below the table is a summary row showing a total of 5 connections. The bottom pane shows the 'Sales Order Maintenance' form with fields for Order, Sold-To, Bill To, and Ship-To, along with an Attachments window.

Status	ID	Process ID	User ID	Device	User IP	Maximum Connections	Program	User Connected Time	Close
Idle	103	0	null		null	0	null		Close
Idle	101	0	null		null	0	null		Close
Idle	102	0	null		null	0	null		Close
Busy	104	3018	sti	col49 48	167.3.9.60	20	mgssmt.p	Thu Jul 21 11:18:24 PDT 2011	Close
Busy	105	21337	sti	col49 28	167.3.9.60	20	sosomt.p	Thu Jul 21 11:30:22 PDT 2011	Close
Total	5								Refresh Close All

Sales Order Maintenance

Header: Lines Trailer

Header: Details Tax info Freight Data Salesperson Delivery Consignment Comments

Header: Order: S071773 Sold-To: ckc-001 Bill To: ckc-001 Ship-To: ckc-001

Sold-To: CKC-001 Ship-To: CKC-001

Headoffice: Hamilton House Headoffice: Hamilton House

Limerick: NJ 0010 Limerick: NJ 0010

United States United States

Attachments: Order S071773

Heartbeat Monitor

Heartbeat Monitor

- `status.jsp` — returns a status message containing the number of agents that are All / Idle / Init / Busy
- `idle.jsp` — returns a page containing the number of idle connections
- `busy.jsp` — returns a page containing the number of busy connections
- `init.jsp` — returns a page containing the number of initializing connections

User Count Log File

User Count Log File

Located in /webapps/<qaducfg>/WEB-INF/logs/usercount.log

```
2011-07-11 06:26:47,554 apisource=AppShell at=s d=QP ip=10.167.3.1 s=TMP6 sid=TMP6 t=li u=mfg
2011-07-11 06:35:58,879 a=sobr009.p apisource=AppShell at=s d=QP s=TMP6 sid=TMP6 t=ai u=mfg
2011-07-11 06:36:00,643 a=sobr009.p apisource=AppShell at=s d=QP s=TMP6 sid=TMP6 t=ao u=mfg
2011-07-11 06:36:10,355 a=mgdbiq.p apisource=AppShell at=s d=QP s=TMP6 sid=TMP6 t=ai u=mfg
2011-07-11 06:36:42,728 a=mgdbiq.p apisource=AppShell at=s d=QP s=TMP6 sid=TMP6 t=ao u=mfg
2011-07-11 06:37:32,866 apisource=AppShell at=s d=QP s=TMP6 sid=TMP6 t=lo u=mfg
2011-07-11 06:37:36,817 apisource=AppShell at=s d=QP ip=10.167.3.1 s=TMP9 sid=TMP6 t=li u=mfg
2011-07-11 06:39:50,038 a=sosomt.p apisource=AppShell at=s d=QP s=TMP9 sid=TMP6 t=ai u=mfg
2011-07-11 06:40:15,754 a=sosomt.p apisource=AppShell at=s d=QP s=TMP9 sid=TMP6 t=ao u=mfg
2011-07-11 06:40:16,120 apisource=AppShell at=s d=QP s=TMP9 sid=TMP6 t=lo u=mfg
2011-07-11 06:40:49,743 servletcontextpath=%2Fdr01%2Ftomcat%2Fwebapps%2Fqaddemo%2F t=webappstop
```



Adding Custom Menus

Adding Custom Menus

- Must be created within an existing Menu or Menu Group
- Multiple ways to create new menus, depending on release
- **Example:** in Menu System Maintenance, add menu 88.1 under new menu group called "My Custom Menu Group":
 1. Create an entry for A.9. Assign a label (ex. My Custom Programs) and execute procedure of "A.9"
 2. Create an entry for A.9.88. Assign a label (ex. Custom Sales Orders) and execute procedure of "88"
 3. Create an entry for 0.88. Assign a label (ex. Custom Sales Orders) and execute procedure of "88"
 4. Create an entry for 88.1. Assign a label (ex. Custom Sales Order Maintenance) and execute procedure with the program name (for example: xxsomt.p).

Adding Custom Menus

- Each program in the QAD .NET UI must have a record both in Menu System Maintenance and Program Information Maintenance
- What needs to be set on Menu System Maintenance for each custom item:

Program Type	Web Logic Implemented	Type
Browses, lookups	Yes	Blank
Special HTML programs such as Browse Maintenance and Kanban workbenches	Yes	Blank
HTML reports and inquiries	No	Desktop
HTML maintenance programs	No	Desktop

Adding Custom Menus

- Multi Domain field set for options that update data that applies to all domains in a database

Program Information Maintena... X

Go To Actions Copy Print Preview

Program:

Selection Label: Country Code Maintenance

Multi Domain:

Web Options

Image: Maint

Web Logic Implemented:

Type: desktop

Adding Custom Menus

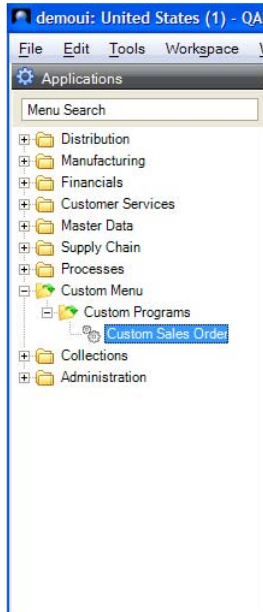

Using Attachment Maintenance

Using Attachment Maintenance

- Document Type
 - *Data Type*. Specify a data type identifier for organizing attachments
 - *Label*. Specify a label for organizing attachments
- Program Name
 - *Program Name*. Specify a program that you want to have include attachments. You must also specify a field
 - *Key Field*. Specify a field that will trigger acceptance of attachments (required)
 - The field must exist on the first frame of the program
- Adding a file as an attachment
 - Drag the file and drop it within the attachment area
 - Right-click the attachment area, select attach, browse to local folders, select file
- Removing an existing file attached
 - Right-click the file already attached, select delete

Enable Attachments to Sales Order Maintenance

Enable Attachments to Sales Order Maintenance

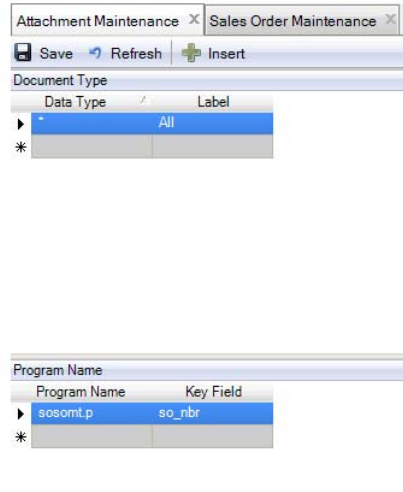

Attachments to Sales Order Maintenance

Attachments to Sales Order Maintenance

Sales Order Maintenance x

Go To Actions Copy Print Preview Attach

Attachments (2)

item.p (3.96 KB)

companyLogo.bmp (31.69 KB)

Header Lines Trailer

Header Details Tax Info Freight Data Salesperson Delivery Consignment Comments

Header

Order: Sold-To: Bill To: Ship-To:

Sold-To: Ship-To:

Details

Order Date:	Line Pricing: <input type="checkbox"/>	Confirmed: <input type="checkbox"/>	
Required Date:	Manual:	Currency:	Language:
Promise Date:	Site:	Taxable: <input type="checkbox"/>	
Due Date:	Channel:	Fixed Price: <input type="checkbox"/>	
Perform Date:	Project:	Credit Terms:	
Pricing Date:		Credit Terms Interest %:	
Purchase Order:		Reprice/Edit: <input type="checkbox"/>	
Remarks:		Entered By:	

ADM_ADM_290

Active Directory Authentication

Active Directory Authentication

- The QAD .NET UI supports Microsoft's Active Directory authentication
- Enforce OS User ID option in Security Control must be enabled
- User passwords can be centrally managed
- User accounts in the QAD system must match the Active Directory User ID
- The User ID in QAD system is limited to eight characters

Enabling Active Directory Authentication

Enabling Active Directory Authentication

- `/webapps/qadhome/configuration/default/client-session.xml`
- Remove the comments (denoted by `<!--` and `-->`) around `<QAD.Authentication.ActiveDirectory>` and set it to true
- In Security Control, enable Enforce OS User ID option
- In User Maintenance, define users and set their passwords to blank

Active Directory Limitations

Active Directory Limitations

- Once Active Directory is enabled, the following are enforced during authentication:
 - Users' computers must be joined to the domain (Windows) for Active Directory authentication
 - Local accounts are not supported
 - Blank passwords are not supported (password is validated against Active Directory)
 - User ID set up within Active Directory must be eight characters or less (QAD has limitation on user ID of that size)

Messaging and Workflow Inbox

Messaging and Workflow Inbox

- QAD .NET UI includes a messaging capability to send messages and workflow information to other users of the system

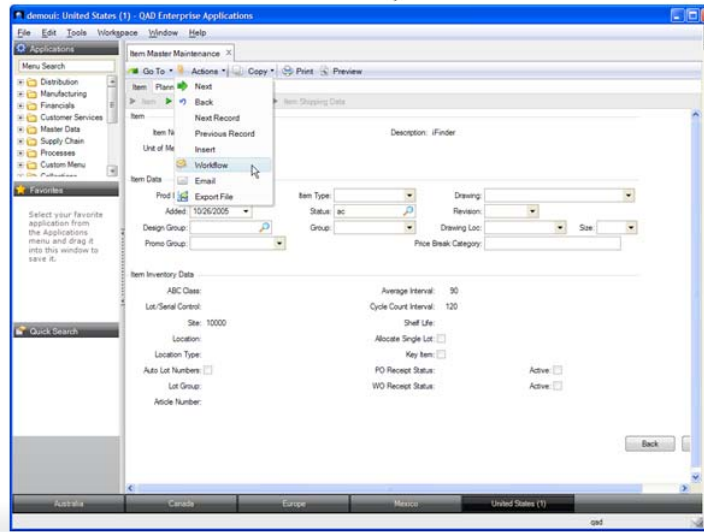

Messaging and Workflow Inbox

- Choose Actions | Workflow
- Compose a workflow message to a system user
- System adds link to current program and context

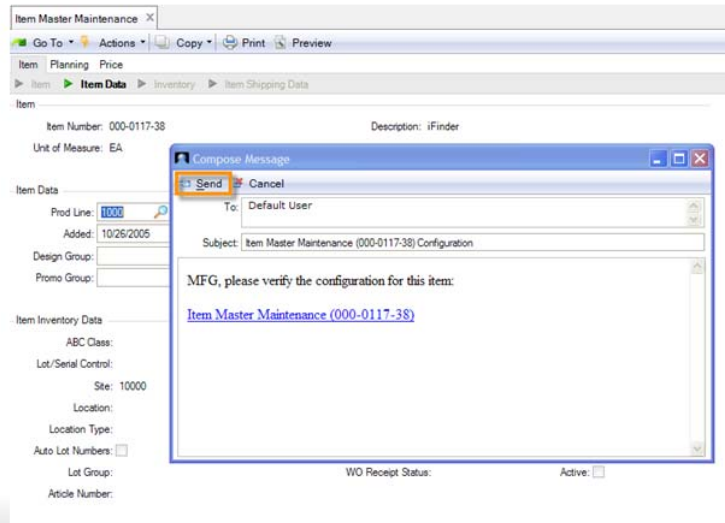

Messaging and Workflow Inbox

- Choose Actions | Email

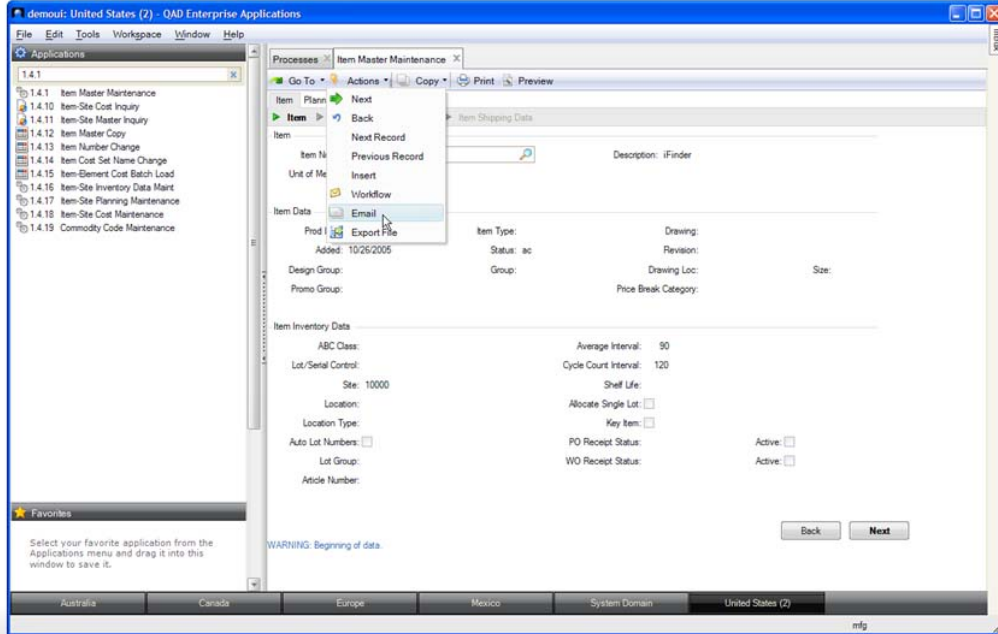

Messaging and Workflow Inbox

- Uses your default email client configured on client PC

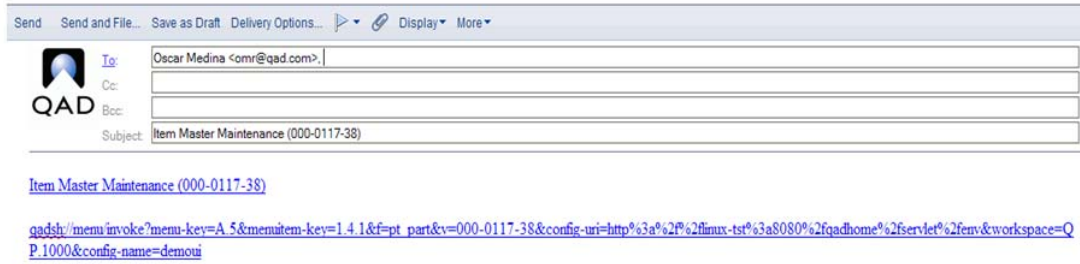

Adding Custom Links

Adding Custom Links

- Open the program that you want to update and select Go To | Add Link

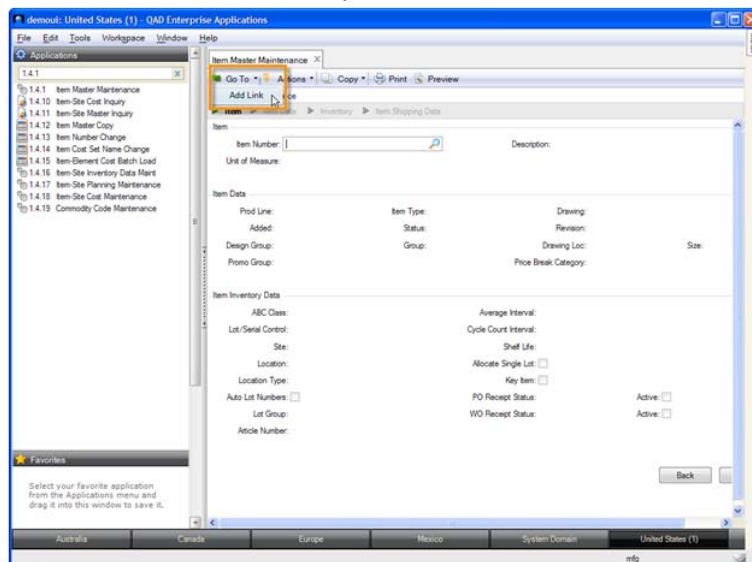

Adding Custom Links

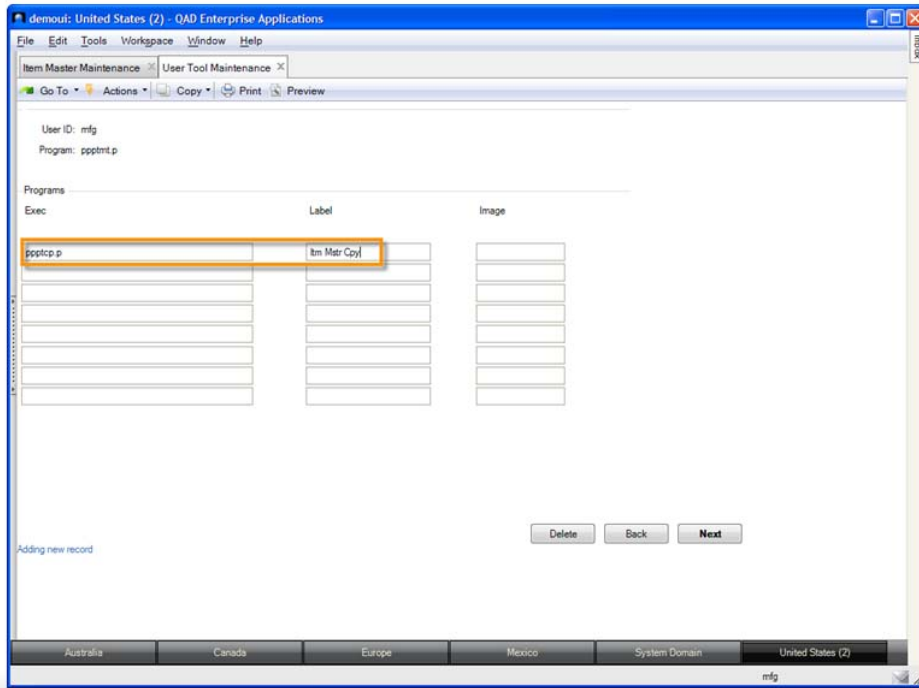

Adding Custom Links

- To validate the link, close and reopen the option

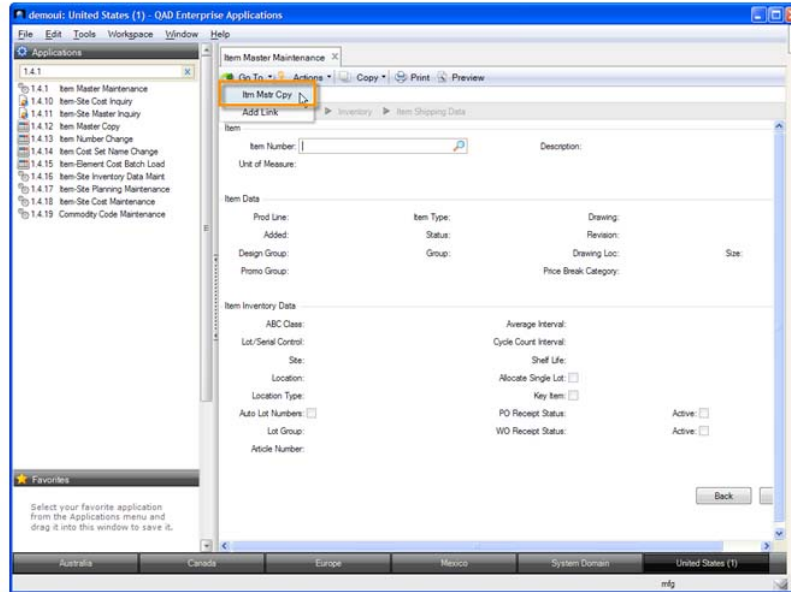

Adding Transaction Comments

Adding Transaction Comments

- 15 lines per page maximum
- Cut and paste enabled

Work Order Maintenance X

Go To Actions Copy Print Preview

Transaction Comments

Page: 1
Master Reference: Za1
Language: us
Type: CM
Page:

```
Java 1.4 versions may be used; however, they are incompatible with the Tomcat 5.5.9 that is delivered on the QAD UI media without additional configuration.  
In general, the best solution is to install J2SE 5.0 or later on the Tomcat server. If you require J2SDK 1.4, refer to the RUNNING.txt file located in the TomcatInstallDir for configuration steps. The compatibility files referenced in RUNNING.txt are available on the QAD UI media in the /tools directory in jakarta-tomcat-5.5.9-compat.zip.  
Java 1.4 versions may be used; however, they are incompatible with the Tomcat 5.5.9 that is delivered on the QAD UI media without additional configuration.  
In general, the best solution is to install J2SE 5.0 or later on the Tomcat server. If you require J2SDK 1.4, refer to the RUNNING.txt file located in the TomcatInstallDir for configuration steps. The compatibility files referenced in RUNNING.txt are available on the QAD UI media in the|
```

Text has exceeded the maximum of 15 rows

Delete Back Next

Embedded Telnet Screens

Embedded Telnet Screens

- Some programs cannot be converted to Desktop mode in QAD .NET UI. These programs display in Terminal mode (the QAD .NET UI's integrated telnet display)
- Some of these programs are:
 - Set Multiple BOL Print Utility
 - Required Ship Schedule Update
 - Call Queue Manager
 - Escalation Monitor
 - Change Deferred/Accrued Accounts
- For a complete list, see QAD .NET UI documentation

Embedded Telnet Screens

- Using SSH for embedded telnet screens:
 - Download `Routrek.granados.dll`
 - `<SshProviderUrl>${HomeServer}/Routrek.granados.dll</SshProviderUrl>`
 - Choose SSH2 instead of telnet
 - `<TerminalProtocol>telnet</TerminalProtocol>`
- Changing the login method for embedded telnet screens in `client-session.xml`:
 - `<add key="TerminalAuthentication" value="ScriptUser" />`
 - `ScriptUser`: The user defined in User Option Telnet Maintenance will be used for telnet login
 - `ShellUser`: The user defined in QAD Enterprise Applications will be used for telnet login
 - `PromptUser`: The user will get prompted for telnet login when using embedded telnet screen

Embedded Telnet Screens

- Defined in User Option Telnet Maintenance

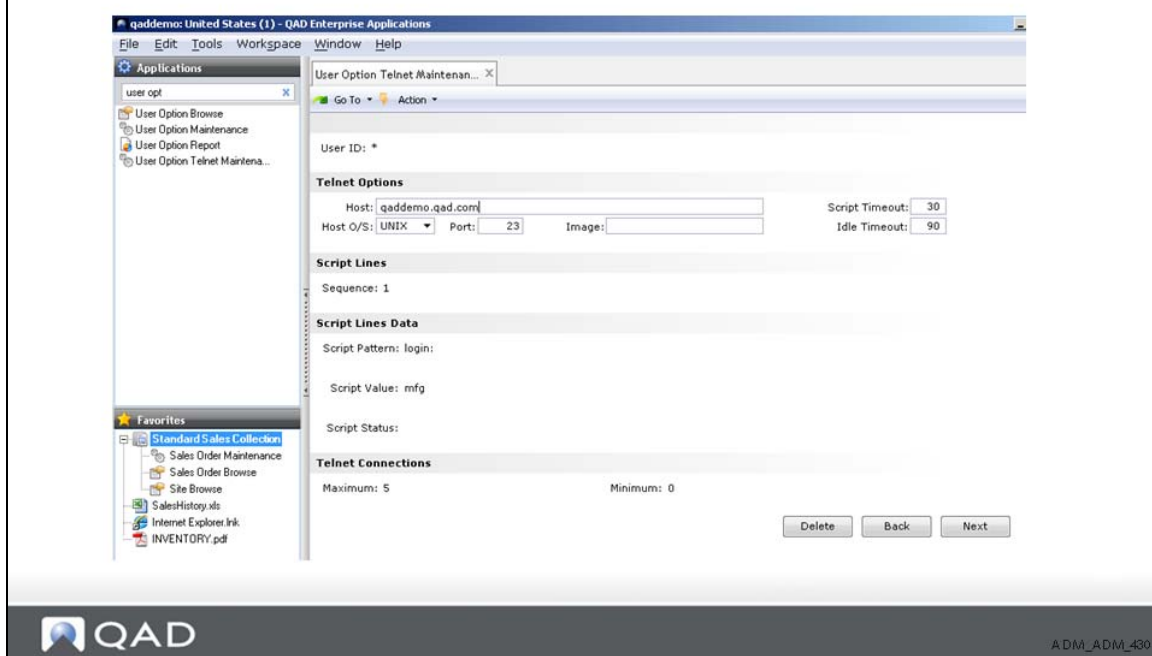

Embedded Telnet Screens

- SSH can be used for embedded telnet screens instead of Telnet
- Steps to configure SSH:
 1. Download Routrek.granados.dll
`<SshProviderUrl>${HomeServer}/Routrek.granados.dll</SshProviderUrl>`
 2. Choose SSH2 instead of telnet
`<TerminalProtocol>telnet</TerminalProtocol>`
- Changing the login method for embedded telnet screens:
 - ScriptUser: user defined in User Option Telnet Maintenance used for telnet login
 - ShellUser: user defined in User Maintenance

Embedded Telnet Screens

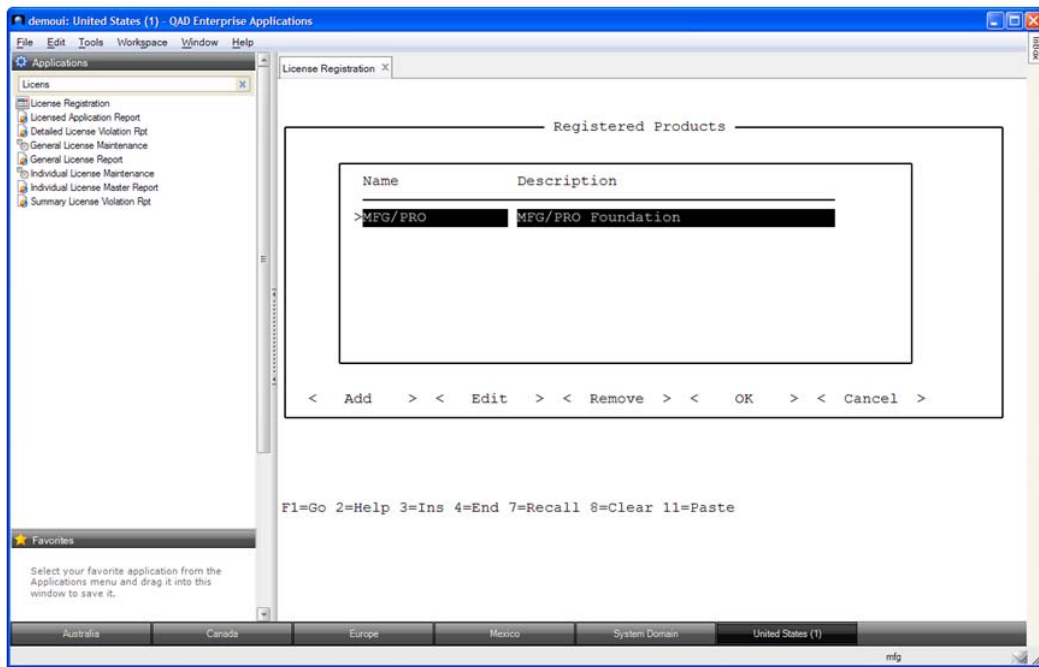

Embedded Telnet Screens

- Maintenance screens can be switched to Terminal mode if they do not have any configurable screen templates assigned.

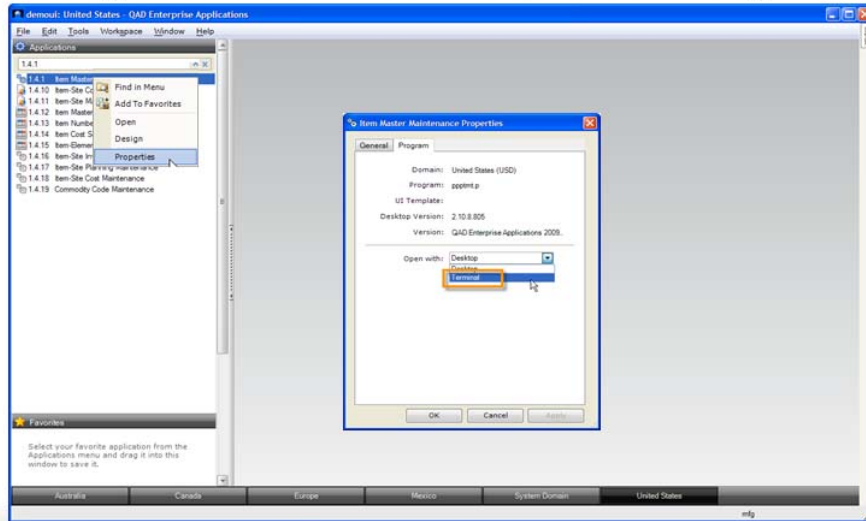

Embedded Telnet Screens

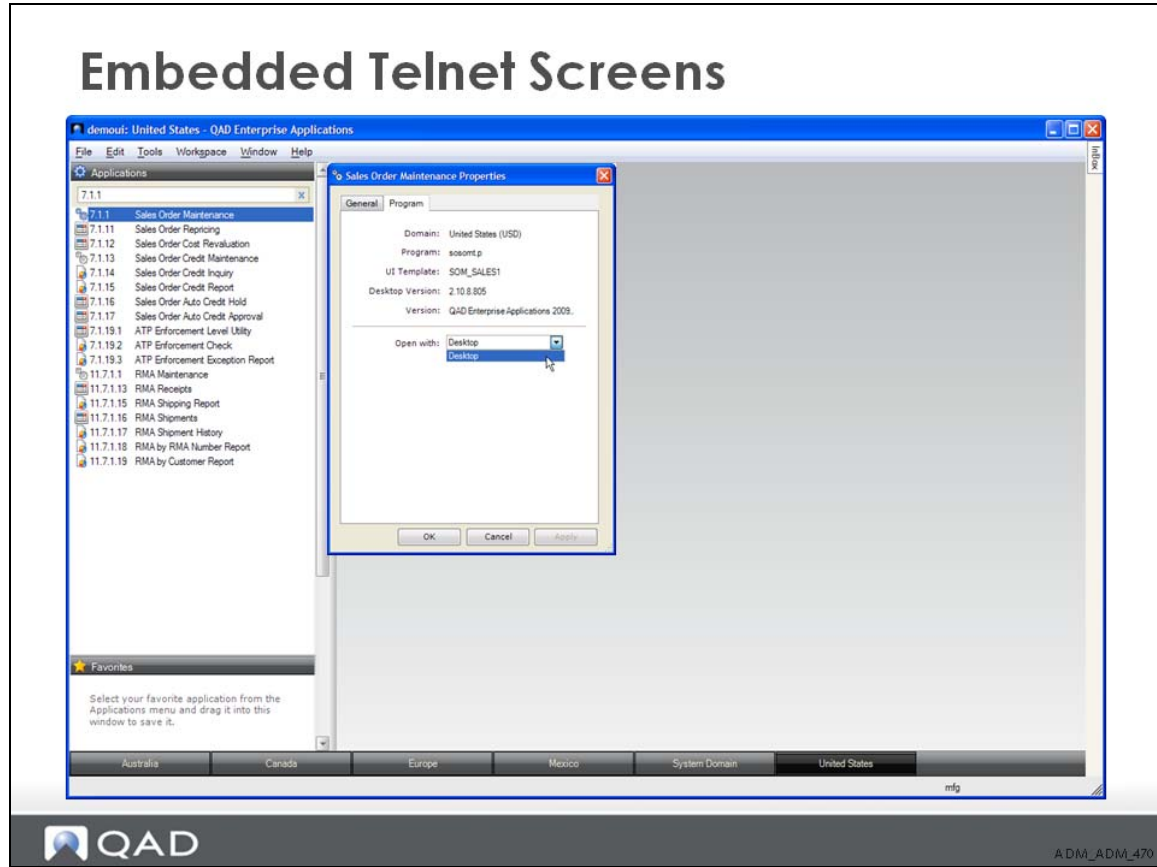

Recording Program Actions

Recording Program Actions

- Program Export File function is a test utility in the QAD .NET UI and is available in the Action menu
- Allows you to record your actions as you complete an application process and save the recorded actions to an .xml or .xls file
- The saved files can be executed in the Execute Document Import function, repeating the recorded process
- Saved files can be exported for testing to another QAD .NET UI environment, or imported into current environment

Recording Program Actions

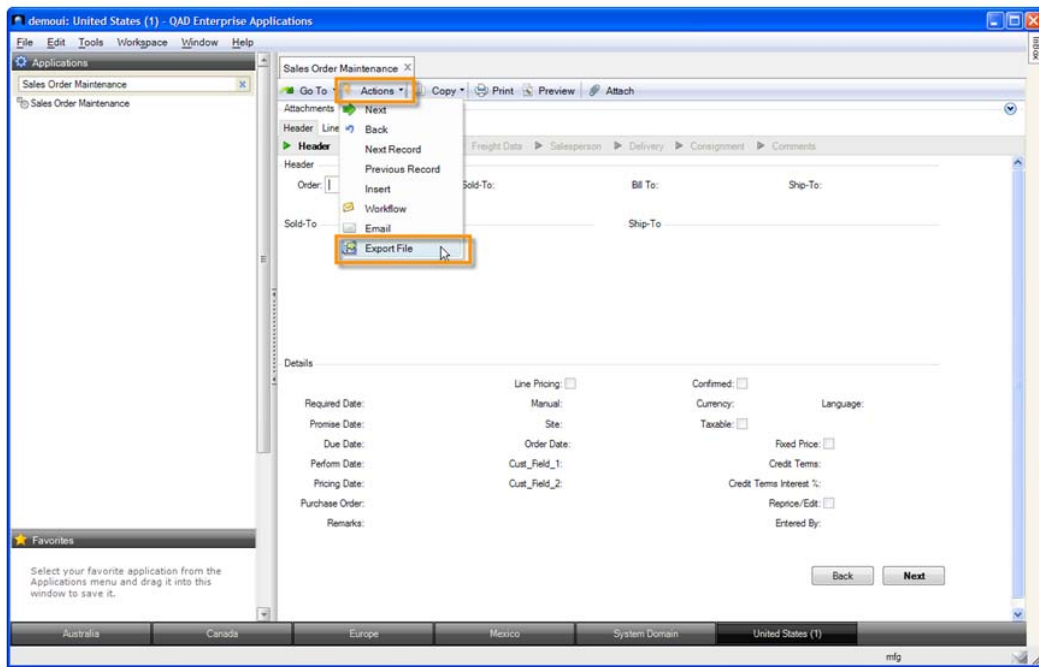

Recording Program Actions

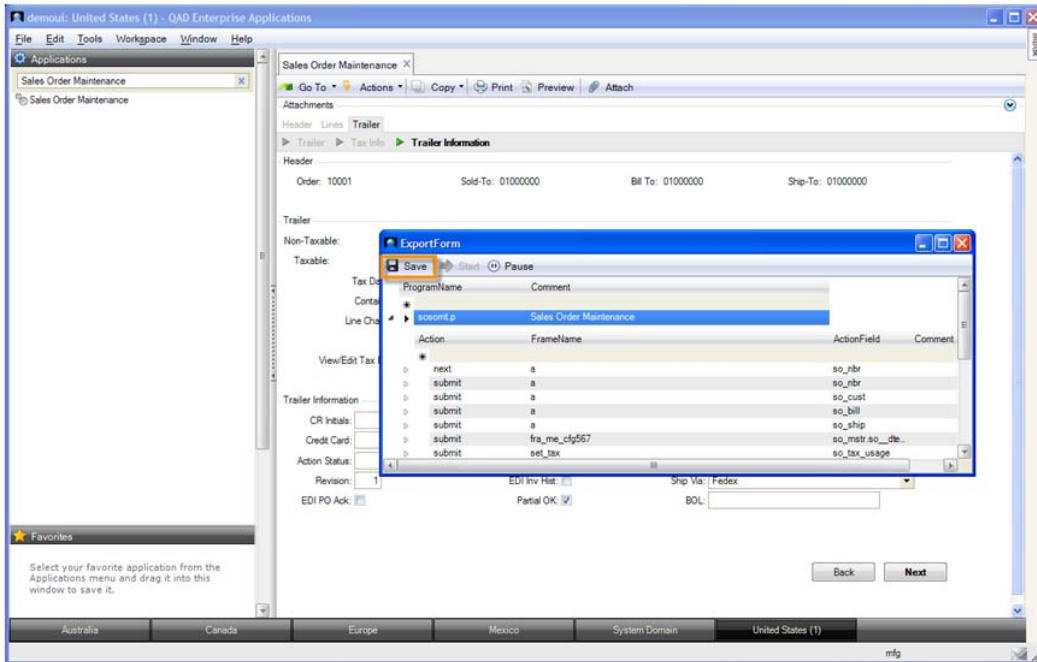

Recording Program Actions

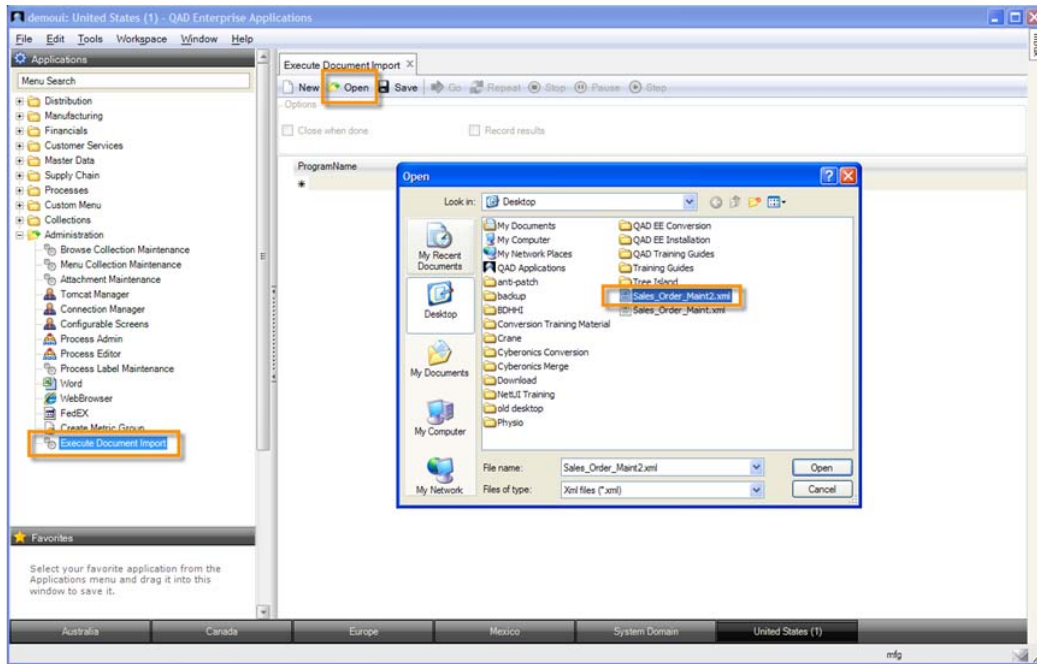

Recording Program Actions

- Run the recording
 - Select Go to execute all the steps or Step to go one step at a time
 - Existing values can be changed and results can be recorded

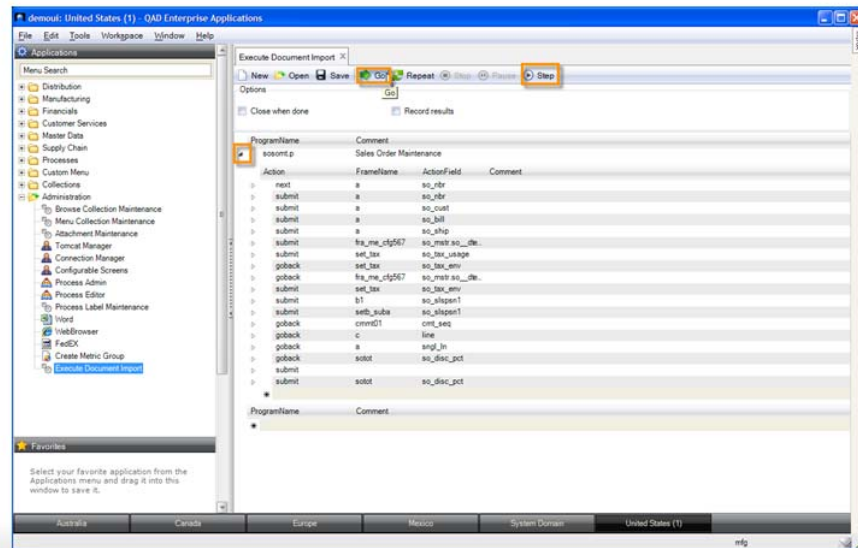

Recording Program Actions

- Recording is executed until it hits an error

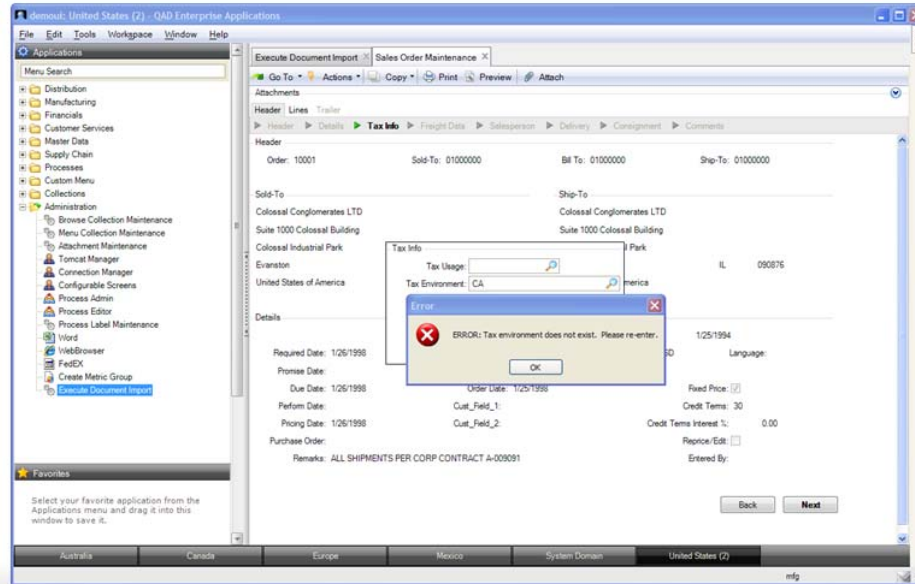

Recording Program Actions

- Execute step-by-step to verify what field is causing the error

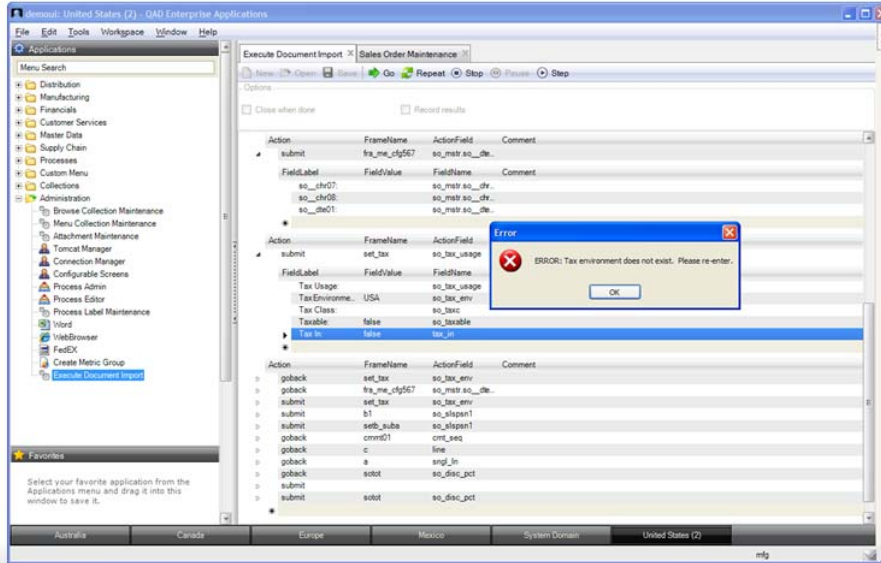

Exercises

Exercises

- Change timeout value in Security Control to 15 minutes and validate that it works
- Add a custom menu item
- Enable attachments for Sales Order Maintenance, add attachment to a sales order, check where file is stored
- Use messaging and workflow inbox
- Use transaction record feature for Sales Order Maintenance
- Create custom links for Item Master Maintenance linking to Item Master Copy
- Change max sessions configuration on User Option Telnet Maintenance; try to open as many programs as you can until you reach the limit

Knowledge Check

- 1 What information is contained in the `client-session.xml` file?
- 2 You define user telnet options in which menu?
- 3 What settings are contained in the `client-bootstrap.xml` file?
- 4 What effect on user navigation does the Maximum field in User Option Telnet Maintenance have?
- 5 What menu do you use to delete defunct users?
- 6 What is the purpose of Heartbeat Monitor?

Chapter 5

Multiple Systems

Chapter Objectives

Chapter Objectives

- The objective of this chapter is to look at aspects of running multiple database instances in different environments

Benefits

Benefits

- You will be aware of the different issues relating to running multiple database instances

Training Flow

Training Flow



- Overview
- Terminology
- Components
- Administration Tasks
- **Multiple Systems**
- Performance Tuning
- Troubleshooting
- Customizing Browsers
- Menu and Browse Collections
- Process Maps
- Configurable Screens

Multiple Databases: Independent Environment

Multiple DB: Independent Environment

- Why?
 - Production, development, training
 - Independent environments
- Considerations
 - Different code streams
 - Different startup parameters
 - Administrative differences

.NET UI Install Review List

.NET UI Install Review List

- Character environment
 - Database parameters
 - Data
 - Application code
- WebSpeed
 - Broker
- AppServer
 - Broker

.NET UI Install Review List (cont.)

- Tomcat
 - WebApplication
- .NET UI
 - Progress Code
 - Configuration

Database Differences

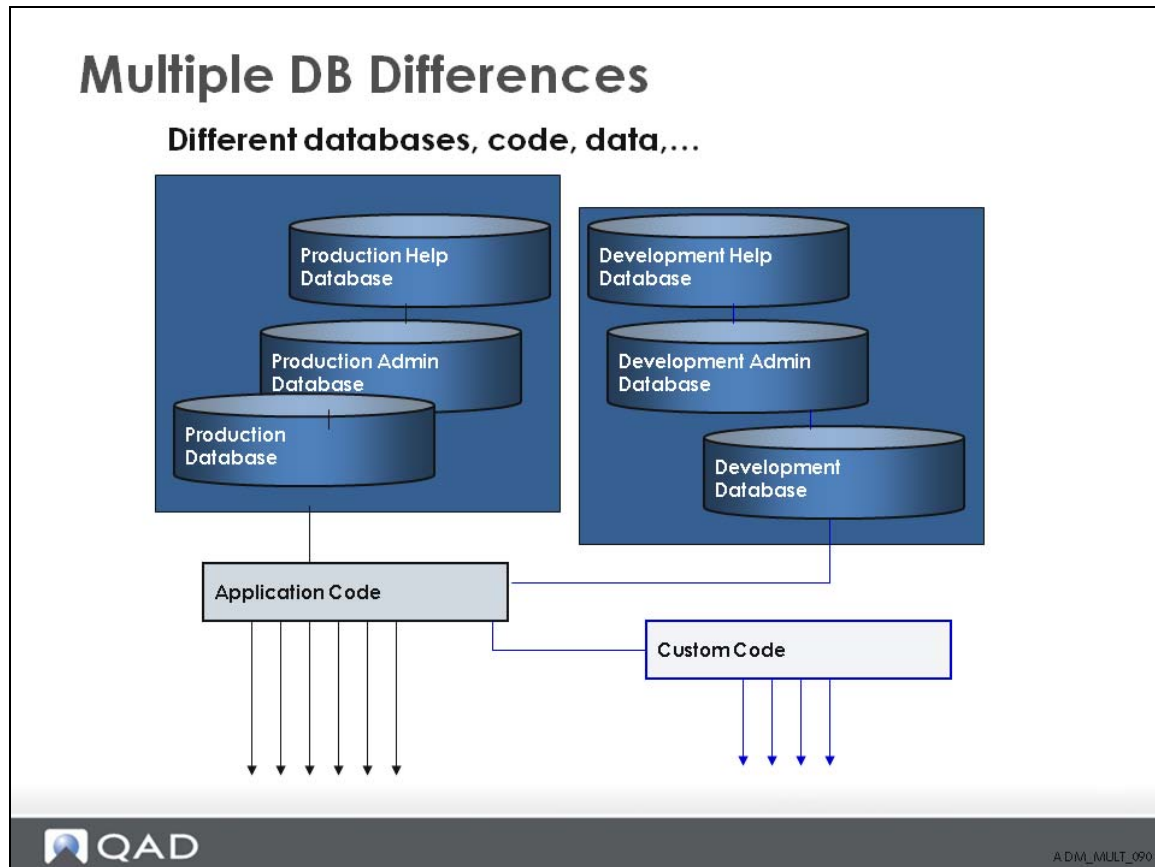

Multiple DB Differences

Differences

- Databases
 - Names
 - Ports
 - Startup parameters

What does this affect?

- Parameter file
 - Telnet file
 - Tomcat file

- Application code

- Propath
 - WebSpeed broker
 - AppServer broker
 - .NET UI build

- Data

Multiple DB – WebSpeed and AppServer Different brokers

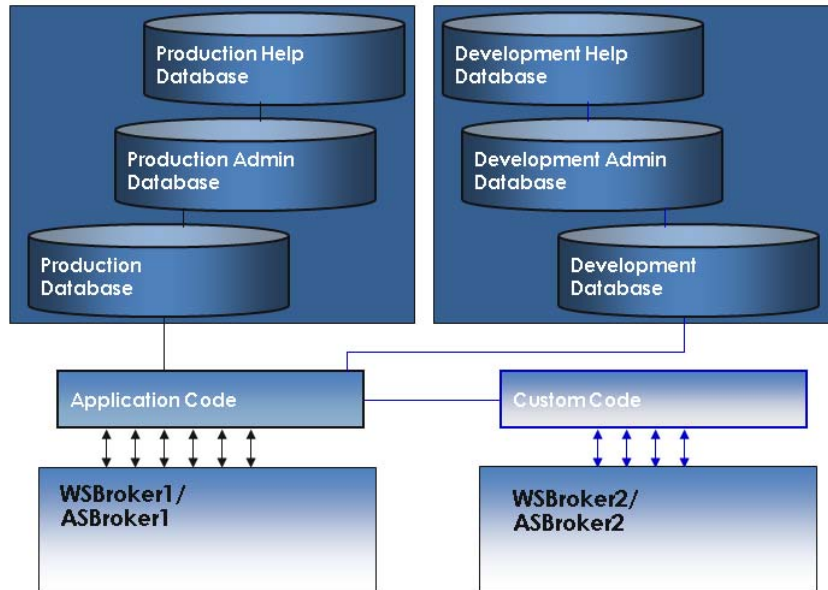

Multiple DB – WebSpeed and AppServer

- Differences
 - WebSpeed Brokers
 - Names
 - Ports
 - Agents/port ranges
 - AppServer Brokers
 - Names
 - Ports
 - Agents/port ranges

Multiple DB – Tomcat

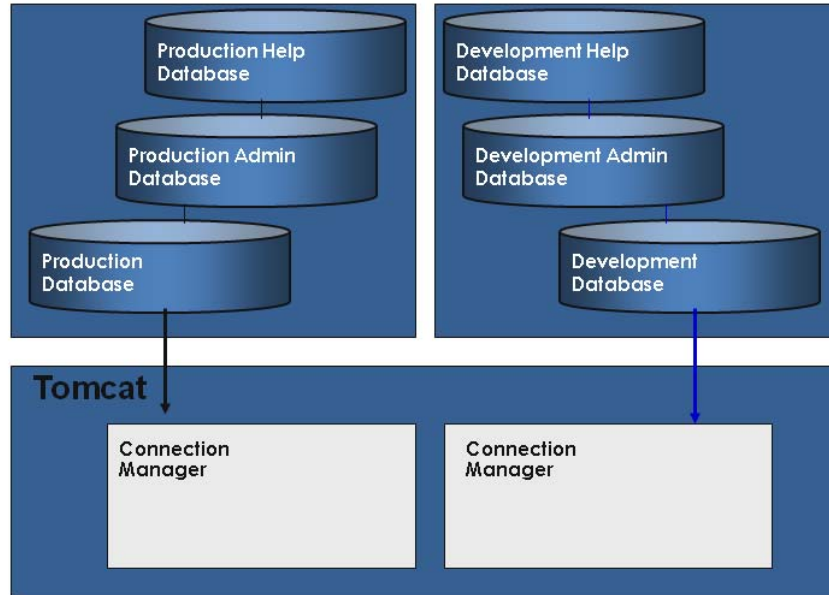

Multiple DB – Tomcat

- No requirement for additional Tomcat servers
- Considerations for additional Tomcat servers
 - Resources (CPU, memory)
 - Administration (starting and stopping)
- Requires a separate .NET UI webapp
 - Different names
 - Different telnet script files
 - Different configuration files

.NET UI Considerations

.NET UI

- Managed by separate client config files in <TomcatInstall>/webapps/qadhome/configurations>
- Each .NET UI installation points to one qadhome server through configuration file:

```
C:\Program Files\QAD\QAD Enterprise Applications
  2007.1\container\QAD.Client.exe.config
<configuration>
<appSettings>
<!-- An HTTP URI to a server that provides backend
  services for the application. -->
<add key="HomeServer"
  value="http://qaddemo:8080/qadhome" />
```
- Users choose .NET UI instance upon login

.NET UI

- Possible to have multiple icons that point to multiple qadhome servers



1. Install multiple instances of .NET UI

Example:

C:\...\Production\QAD\...

C:\...\Test\QAD\...

2. Configure shortcut to use batch file to replace configuration file corresponding to desired environment prior to launching

Example:

The Production icon batch file will copy

Production.QAD.Client.exe.config to QAD.Client.exe.config

Knowledge Check

Consider and list the setup and configuration issues involved in running a multiple database .NET UI environment.

Chapter 6

Performance Tuning

Chapter Objectives

Chapter Objectives

- The objective of this chapter is to describe the different performance tuning techniques you can apply to the installation.

Benefits

Benefits

- You will be able to use memory allocation and database tuning techniques, and to identify optimum client settings and UNIX performance commands.

Training Flow

Training Flow



- Overview
- Terminology
- Components
- Administration Tasks
- Multiple Systems
- **Performance Tuning**
- Troubleshooting
- Customizing Browsers
- Menu and Browse Collections
- Process Maps
- Configurable Screens

Overview

Overview

- Performance considerations
- Tomcat tuning
- Database tuning
- Client considerations
- UNIX tools
- Kernel considerations

Performance Considerations

Performance Considerations

- Impact of poor performance:
 - Lost productivity
 - Lost customer confidence and credibility
 - Lost revenue
 - Lower morale
 - Financial penalties

Performance Considerations

- Typical performance problems include:
 - Slow and unresponsive applications
 - Applications that get slower over time
 - Memory leaks and unindexed database queries can cause performance issues
 - Applications that crash (either themselves or the server)
 - Lack of reliability
 - CPU usage spikes and application freezes
 - Applications that get slower as more users log in
 - Lack of scalability
 - Business functions that fail to complete within established timeframes
 - Backups
 - MRP
 - Advanced Shipment Notice (ASN) generation

Performance Considerations

- Defining the problem
 - All users are experiencing slow performance?
 - Identify the users that report slow performance, verify what they were doing
 - What interface being used?
 - Has the program always run slowly?
 - Anything changed on the system (operating system or application patch)?
 - Can the problem be reproduced?
 - Who is having the problem (local or remote users)?

Performance Considerations

Change One Thing At A Time

Tomcat Tuning

Tomcat Tuning

- Memory allocations (Java options)
 - `-server`: Tells java to run optimized for server side
 - `-Xms256m`: Sets initial heap size (this example sets it to 256 MB)
 - `-Xmx256m`: Sets maximum heap size (this example sets it to 256 MB)
 - Set via `CATALINA_OPTS` environment variable
 - `export CATALINA_OPTS="-server -Xms256m -Xmx256m"`

Database Tuning

Database Tuning

- Standard database tuning
- Make sure to set the `-n` parameter
 - This sets the maximum number of connections a database can have
 - This value should exceed
Max WebSpeed agents + Max AppServer agents + Max tomcat agents + Max character connect + Max telnet connects
- User Option Telnet Maintenance
 - Max value = Maximum number of telnet connections a user can have **and** Maximum number of active HTML maintenance programs a user can have
 - Min value = Number of idle telnet connections a client will have
 - **RECOMMEND SETTING THIS VALUE TO "0"**

Database Tuning

- Database growth should take place in fixed extents
- BI should have enough fixed extents to grow, and reside on a different set of disks than data and AI
- Use AI Management tool to manage AI extents; these should reside on a different set of disks than BI and data
- Always start BIW, AIW (if AI enabled), APW and WDOG background processes
- Checkpoints should not be taking place more than every 2 minutes

Database Tuning

- Buffer hits should be 85% or better; increase this parameter if Buffer Hits go below 85%
- Avoid RAID 5
- If a massive Delete and Archive activity took place recently on your environment, plan to dump and load
- Use QoS (Quality of Service) or protocol prioritize

Client Considerations

Client Considerations

- HTML Rendering is CPU-intensive
- A P400 PC will see its processor peg at 100% with each page rendering
- Recommend at least 1.6 GHz
- Recommend double the OS required memory
- Recommend 1GB of hard disk space

Unix Tools: top

Unix Tools

- top / topas

```

root@coli22:/dr01/mfgpro/tomcat-8080/bin
12:35pm up 75 days, 21:52, 45 users, load average: 1.99, 1.91, 1.71
794 processes: 792 sleeping, 2 running, 0 zombie, 0 stopped
CPU0 states: 7.2% user, 48.1% system, 0.0% nice, 43.1% idle
CPU1 states: 9.1% user, 32.0% system, 0.0% nice, 58.0% idle
Mem: 1028368K av, 1023272K used, 5096K free, 14120K shrd, 3752K buff
Swap: 2048248K av, 384116K used, 1664132K free, 140584K cached

```

PID	USER	PRI	NI	SIZE	RSS	SHARE	STAT	%CPU	%MEM	TIME	COMMAND
9815	root	17	0	1944	1940	956	R	60.5	0.1	0:03	top
10642	nobody	11	0	26992	25M	496	S	12.4	2.5	450:01	smbd
26579	root	9	0	10856	10M	1844	D	10.1	1.0	62:48	smbd
31110	root	9	0	14364	4932	1572	S	3.5	0.4	13:16	java
1807	root	9	0	10628	8756	7756	S	1.5	0.8	5:36	_progres
26740	root	10	0	202M	139M	60032	S	1.5	13.8	0:37	java
3175	named	9	0	44212	40M	36888	S	0.7	4.0	98:38	named
22803	nobody	9	0	27256	26M	2728	S	0.7	2.6	30:27	smbd
9812	root	9	0	2056	2056	1476	S	0.3	0.1	0:00	vim
1	root	8	0	120	72	72	S	0.0	0.0	0:08	init
2	root	9	0	0	0	0	SW	0.0	0.0	0:00	keventd
3	root	19	19	0	0	0	SWN	0.0	0.0	0:05	ksoftirqd_CPU0
4	root	19	19	0	0	0	SWN	0.0	0.0	0:06	ksoftirqd_CPU1
5	root	9	0	0	0	0	SW	0.0	0.0	18:44	kswapd
6	root	9	0	0	0	0	SW	0.0	0.0	5:30	kreclaimd
7	root	9	0	0	0	0	SW	0.0	0.0	0:51	bdflush

Unix Tools: free

Unix Tools

- Check memory with `free`

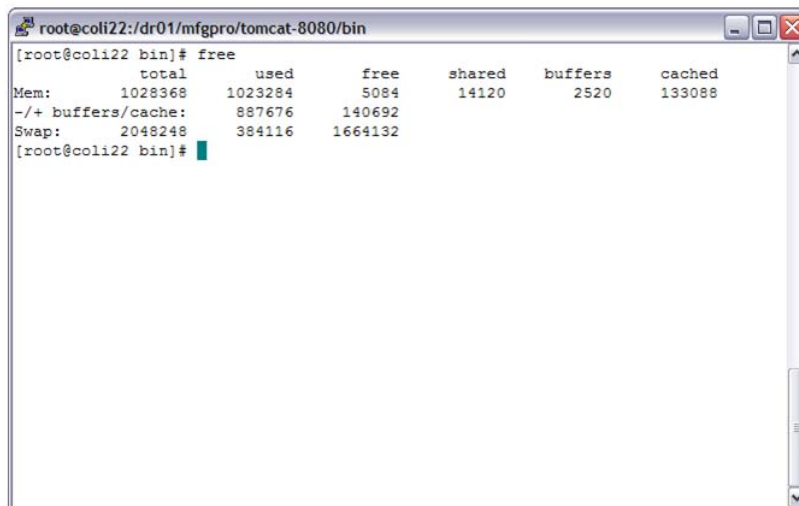

```
root@coli22:/dr01/mfgpro/tomcat-8080/bin
[root@coli22 bin]# free
              total        used         free       shared    buffers     cached
Mem:          1028368      1023284         5084        14120        2520       133088
-/+ buffers/cache:    887676       140692
Swap:         2048248       384116       1664132
[root@coli22 bin]#
```

Unix Monitoring Tool: sar

Unix Monitoring Tool: sar

- `sar` is an excellent performance monitoring tool:
 - Found on nearly all Unix platforms
 - Excellent for recording large and varied amounts of system information
 - Can run automatically to provide daily performance summary or interactively for spot checking
 - Flexible, powerful, non-intrusive, accurate
 - Useful for monitoring all aspects of operating system performance

Other Unix Tools

Other Unix Tools

- `lsof`
 - Lists open files on system
 - A way of tracking down process associated with a port
- `ipcs`: Provides information on ipc facilities
- `who`: Shows who is logged into system
- `ps -elf / ps -defa`
 - Shows active processes
 - Will want to redirect to file for viewing
 - Will want to pipe it to a `grep` command for filtering

Kernel Considerations

Kernel Considerations

- Maximum number of open files
- Maximum number of telnet connections
- Terminal type
- Java threading

Kernel Considerations: Max Telnet Connections

Kernel Considerations

- Max number of telnet connections
For Linux, modify /etc/xinetd.conf

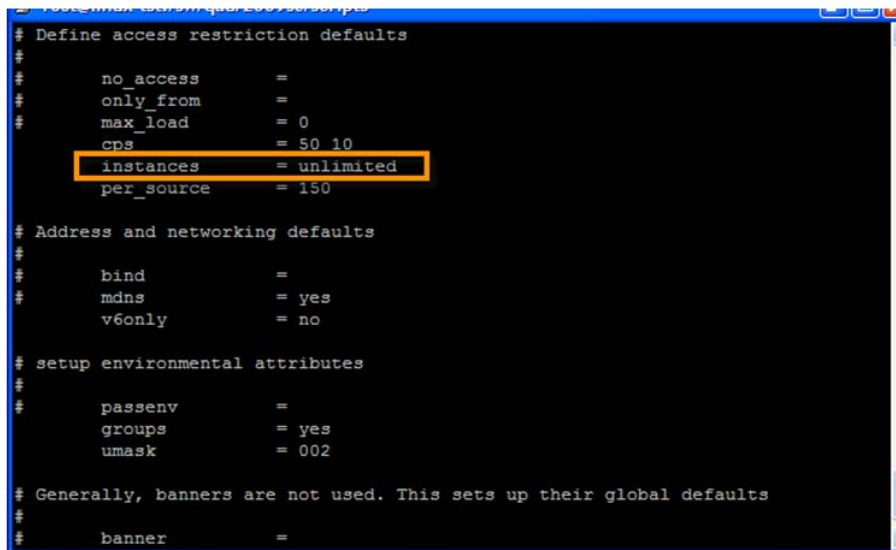

```
root@max:~/bin/qa/100/scr/ps
# Define access restriction defaults
#
#   no_access          =
#   only_from         =
#   max_load          = 0
#   cps               = 50 10
#   instances         = unlimited
#   per_source        = 150
#
# Address and networking defaults
#
#   bind              =
#   mdns              = yes
#   v6only            = no
#
# setup environmental attributes
#
#   passenv           =
#   groups            = yes
#   umask             = 002
#
# Generally, banners are not used. This sets up their global defaults
#
#   banner            =
```

Kernel Considerations: File Handles

Kernel Considerations

- File handles
 - The total amount of allowable processes and open files might need to be raised
 - Controlled in `/etc/security/limits.conf`

```
#<domain>      <type>  <item>      <value>
#
*               soft    nproc       2047
*               hard    nproc       16384
*               soft    nofile      1024
*               hard    nofile      65536
```

Kernel Considerations: Shared Memory

Kernel Considerations

- Shared memory and other sysctl tunables
- Add the following to `/etc/sysctl.conf`

```
kernel.core_uses_pid = 1
kernel.shmmax = 2147483648
kernel.shmni = 4096
kernel.shmall = 2097152
kernel.sem = 500 32000 200 256
fs.file-max = 65536
net.ipv4.ip_local_port_range = 1024 65000
```

Kernel Considerations: Disable Bigpages

Kernel Considerations

- Disable bigpages
 - Enabling bigpages (large virtual memory page sizes) can result in a reduction in application performance
- Novell: `kernel.shm-use-bigpages = 0`
- Redhat: `vm.hugetlb_pool = 0`

Kernel Considerations: I/O Scheduler

Kernel Considerations

- Starting with the 2.6 kernel, the I/O scheduler can be changed at boot time to control the way the kernel commits reads and writes to disks
- Add `elevator=deadline` to `/etc/grub.conf` configuration file, for example:

```
kernel /vmlinuz-2.6.18-8.el5 ro  
root=LABEL=/rhgb quiet  
crashkernel=128M elevator=deadline
```

xinetd.d

xinetd.d

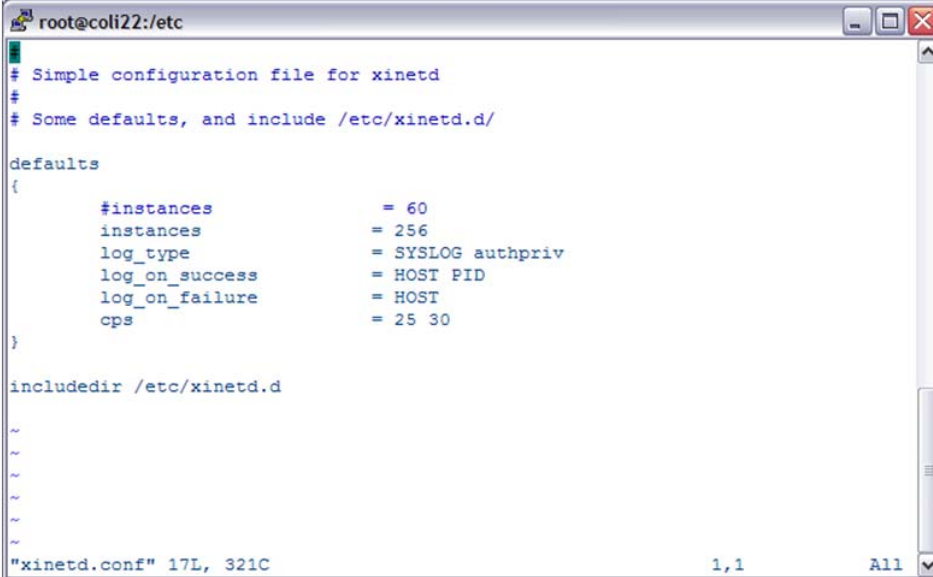

```
root@coli22:/etc
# Simple configuration file for xinetd
#
# Some defaults, and include /etc/xinetd.d/

defaults
{
    #instances           = 60
    instances            = 256
    log_type              = SYSLOG authpriv
    log_on_success        = HOST PID
    log_on_failure        = HOST
    cps                   = 25 30
}

includedir /etc/xinetd.d

~
~
~
~
~
"xinetd.conf" 17L, 321C          1,1          All
```

Additional Resources

Additional Resources

- [QAD .NET UI Deployment Guide](#)

Knowledge Check

- 1 In standard database tuning, what is the purpose of the `-n` parameter?
- 2 What is the purpose of the `lsof` and `ps -elf` UNIX commands?
- 3 What is the function of the `xinetd.d` program?

Chapter 7

Troubleshooting

Chapter Objectives

Chapter Objectives

- The objective of this chapter is to describe troubleshooting techniques, commands, and logs for the QAD .NET UI

Benefits

Benefits

- You will be able to identify
 - Basic troubleshooting techniques based on standard startup sequence types
 - possible test points and database connections
 - troubleshooting commands for servers
 - Applicable system logs

Training Flow

Training Flow



- Overview
- Terminology
- Components
- Administration Tasks
- Multiple Systems
- Performance Tuning
- **Troubleshooting**
- Customizing Browsers
- Menu and Browse Collections
- Process Maps
- Configurable Screens

Overview

Troubleshooting

- Troubleshooting basics
- Startup sequence
- Test points
- Tools and Logs
- Exercises

Troubleshooting Basics

Troubleshooting Basics

- Everyone will develop their own troubleshooting techniques
- QAD .NET UI is not a diagnostic tool, it is an application; however, it can be used to gather important troubleshooting indications
 - Can you log on?
 - Can you run browses?
 - Can you run HTTP Maintenance programs?
 - Can you run Telnet Maintenance programs?
 - Do the URL links work?
 - Are the screens correctly rendered?
 - Do the SE programs run in a character client?
- Develop a list of test points

.NET UI Startup Sequence

.NET UI Startup Sequence

- The startup sequence is important to a point
 1. The database servers must be started before the other Desktop components
 2. Admin Server and Name Server
 3. WebSpeed Brokers: Will require restart if the databases are bounced
 4. AppServer Brokers: Will require restart if the databases are bounced
 5. Tomcat
 6. Connection Manager: Will also require restart if the databases are bounced

Troubleshooting Test Points

Troubleshooting Test Points

- Possible test points
 - Databases
 - Admin Sever – Name Server
 - WebSpeed/AppServer brokers, agents, and messengers
 - Tomcat Server
 - Connection Manager
 - Correct operation of both telnet scripts
 - User Option Telnet Maintenance Telnet Script
 - Connection Manager Telnet Script
 - Then – what does the client do or not do
 - Login?
 - Run browses?
 - Run HTTP Maintenance?
 - Run Telnet Maintenance
 - Are the screens rendered correctly?

Database Connections

Database Connections

- Are all the necessary databases running?
- Are there a reasonable number of database connections?
 - Use a sanity check to account for the number of database connections
 - Connections for the WebSpeed brokers
 - Connections for the AppServer brokers
 - Connections for each Connection Manager instance
 - Connections for Telnet Maintenance
 - Connections for any character users
 - Connections for batch processes
 - Have the databases been bounced?

Check the Databases: PROMON

Check the Databases

- Use PROMON
 - How many users are logged on?
 - Does the number match the configuration?
 - Does the `-n` accommodate enough logins on all of the databases?
 - Are there users from all WebSpeed Brokers?

```

Rec Lock Waits    0 %   BI Buf Waits    0 %   AI Buf Waits
Writes by APW    0 %   Writes by BIW   0 %   Writes by AIW
Buffer Hits      99 %
DB Size          158 MB
FR chain         0 bloc
Shared Memory    8960 K

0 Servers, 17 Users (17)
RETURN - repeat, U - con

Enter your selection: 8
usr  pid  time of login  user id  tty Limbo?
6    386  Mon Sep 16 14:27:03 2002 dtremote /dev/pts/12
7    4285 Fri Sep 13 08:40:28 2002 root     batch
8    388  Mon Sep 16 14:27:03 2002 dtremote /dev/pts/15
9    387  Mon Sep 16 14:27:03 2002 dtremote /dev/pts/13
10   389  Mon Sep 16 14:27:03 2002 dtremote /dev/pts/14
11   4390 Fri Sep 13 08:41:18 2002 root     batch
12   394  Mon Sep 16 14:27:04 2002 dtremote /dev/pts/16
13   436  Mon Sep 16 14:27:14 2002 dtremote /dev/pts/17
15   4593 Fri Sep 13 08:44:34 2002 dt2      /dev/pts/3
16   4592 Fri Sep 13 08:44:34 2002 dt2      /dev/pts/2
17   4857 Fri Sep 13 08:45:34 2002 dt2      /dev/pts/6
18   4879 Fri Sep 13 08:45:34 2002 dt2      /dev/pts/5
19   4878 Fri Sep 13 08:45:34 2002 dt2      /dev/pts/9
20   4882 Fri Sep 13 08:45:35 2002 dt2      /dev/pts/7
    
```



A.DM_TSH_100

PROMON is a Progress command that displays server, configuration, and user information.

Test the Admin and Name Servers

Test the Admin and Name Servers

- Test the Admin Server

proadsv -query

```
(root) /apps/progress/91d/bin $ proadsv -query  
PROGRESS Version 9.1D as of Wed May 8 16:47:54 EDT 2002  
AdminServer is alive. (8545)  
(root) /apps/progress/91d/bin $
```

- Test the Name Server

nsman -name NS1 -query

```
(root) /apps/progress/91d/bin $ nsman -name NS1 -query  
PROGRESS Version 9.1D as of Wed May 8 16:47:54 EDT 2002  
  
Connecting to Progress AdminServer using rmi://localhost:20931/Chimera (8280)  
Searching for NS1 (8288)  
Connecting to NS1 (8276)  
  
NameServer NS1 running on Host pl1i01.qad.com Port 5162 Timeout 30 seconds.  
Application Service
```

Test the WebSpeed Brokers

- Test the broker and agents

wtbman -name qaddemo_WS -query

```

root@qaddemo:/dr01/tomcat/webapps/qadhome/client/configs
Connecting to Progress AdminServer using rmi://localhost:20931/Chimera (8280)
Searching for qaddemo_WS (8288)
Connecting to qaddemo_WS (8276)

Broker Name           : qaddemo_WS
Operating Mode        : Stateless
Broker Status         : ACTIVE
Broker Port           : 4160
Broker PID            : 2382
Active Agents         : 1
Busy Agents           : 0
Locked Agents         : 0
Available Agents      : 1
Active Clients (now, peak) : (0, 1)
Client Queue Depth (cur, max) : (0, 0)
Total Requests        : 13
Rq Wait (max, avg)    : (1 ms, 0 ms)
Rq Duration (max, avg) : (8 ms, 1 ms)

PID  State      Port  nRq  nRcvd  nSent  Started      Last Change
02416 AVAILABLE 04173 000006 000006 000006 Jul 31, 2006 20:50 Jul 31, 2006 22:16

[root@qaddemo configs]#

```

Test the AppServer Brokers

Test the AppServer Brokers

- Test the broker and agents

asbman -name qaddemo_AS -query

```

root@qaddemo:/dr01/tomcat/webapps/qadhome/client/configs
Connecting to Progress AdminServer using rmi://localhost:20931/Chimera (8280)
Searching for qaddemo_AS (8288)
Connecting to qaddemo_AS (8276)

Broker Name           : qaddemo_AS
Operating Mode        : Stateless
Broker Status         : ACTIVE
Broker Port           : 4150
Broker PID            : 2446
Active Servers        : 1
Busy Servers          : 0
Locked Servers        : 0
Available Servers     : 1
Active Clients (now, peak) : (0, 0)
Client Queue Depth (cur, max) : (0, 0)
Total Requests        : 0
Rq Wait (max, avg)    : (0 ms, 0 ms)
Rq Duration (max, avg) : (0 ms, 0 ms)

PID  State    Port  nRq  nRcvd  nSent  Started      Last Change
02484 AVAILABLE 04179 000000 000000 000000 Jul 31, 2006 20:50 Jul 31, 2006 20:50

[root@qaddemo configs]#
    
```

Test the WebSpeed Messenger

Test the WebSpeed Messenger

- A simple test of WebSpeed will tell you a lot

Address http://plli01:8080/demo/cgi-bin/wspd_cgi.ksh/WService=wsdemo/ping

Web Object Path (PROPATH):

- /apps/mfgpro/eb2/desktop
- /apps/mfgpro.eb2
- /apps/mfgpro/eb2/bbi
- /apps/progress/91d/tty
- /apps/progress/91d/tty/adecomm.pl
- /apps/progress/91d/tty/adeshar.pl
- /apps/progress/91d/tty/product.pl
- /apps/progress/91d/tty/adeedif.pl
- /apps/progress/91d/tty/adecomp.pl
- /apps/progress/91d/tty/as4dict.pl
- /apps/progress/91d
- apps/progress/91d/bin

Connected Databases:

- qaddb (PROGRESS)
- qadhelp (PROGRESS)
- qadadm (PROGRESS)

Does the broker respond?

Is the PROPATH correct?

Are the correct databases connected?

Ping each service that you are supporting

Verify Tomcat Is Running

Verify Tomcat is Running

- Enter the URL for each Tomcat instance

Address  <http://plli01.qad.com:8080/index.html>



Tomcat
Version 4.0.3



The Jakarta Project
<http://jakarta.apache.org>

Address  <http://pln107:8080/index.html>



Tomcat
Version 4.0.3



The Jakarta Project
<http://jakarta.apache.org>

Test the Tomcat Web App

- Log in to the application and run Connection Manager

The screenshot shows the 'Connection Manager' web application interface. The title bar reads 'Connection Manager'. The sidebar on the left contains the following sections:

- Functions:** Close Connection Manager, Restart Connection Manager, Reset failed init count, Delete HTML cache, Message of the day, Update configuration settings.
- Connections:** All, Busy, Idle, Initializing.
- Users:** (with a 'Refresh' button below it).

The main content area is titled 'Connection Manager - Default/Desktop' and shows the date 'Fri Jul 23 03:06:00 PDT 2010'. Below this is a table with the following data:

Status	ID	Process ID	User ID	Device	User IP	Maximum Connections	Program	U
Idle	166	0	null		null	0	null	
Idle	167	0	null		null	0	null	
Idle	168	0	null		null	0	null	
Idle	169	0	null		null	0	null	
Idle	170	0	null		null	0	null	
Total	5							

- Is Connection Manager functioning?

Troubleshooting Aids: who Command

Other Troubleshooting Aids

- Use the `who` command to differentiate users

```
root pts/0 Sep 13 08:25 (:0)
root pts/1 Sep 13 08:29 (:0)
dt2 pts/7 Sep 13 08:45 (plli01)
dt2 pts/9 Sep 13 08:45 (plli01)
dt2 pts/8 Sep 13 08:45 (plli01)
dt2 pts/10 Sep 13 08:45 (plli01)
mfg pts/11 Sep 17 10:58 (167.3.25.15)
dtremote pts/12 Sep 16 14:27 (plnt07)
dtremote pts/13 Sep 16 14:27 (plnt07)
dtremote pts/14 Sep 16 14:27 (plnt07)
dtremote pts/15 Sep 16 14:27 (plnt07)
dtremote pts/16 Sep 16 14:27 (plnt07)
dtremote pts/17 Sep 16 14:27 (plnt07)
dttelnet pts/18 Sep 17 10:59 (167.3.25.15)
dttelnet pts/19 Sep 17 10:59 (167.3.25.15)
```

Troubleshooting Aids: tail Command

Other Troubleshooting Aids

- Use the `tail` command to view active logs
- `tail -f catalina.out`

```
StateName: Idle
connectionID: 2
ID: null
RequestID: null
SessionID: null
ProcessSeqID:
UserIP: null
UserID: null
program: null
UserMaxSessions: 0
PID: 4592
SessionStart:
AgentStart: Fri Sep 13 08:44:32 PDT 2010
LastAccessedTime: Fri Sep 13 09:31:04 PDT 2010

Init:
Initializing
timing:,,,1032362612673,Connection Mgr Monitor end,10
```

Troubleshooting Aids: Logs

Other Troubleshooting Aids

- Some important logs
 - WebSpeed broker logs:
 - `../qadui/<brokername>/ .broker.log`
 - `../qadui/<brokername>/ .server.log`
 - AppServer broker logs:
 - `../qadui/<brokername>/ .broker.log`
 - `../qadui/<brokername>/ .server.log`
 - Database logs:
 - `<db name>.lg`
 - Tomcat's catalina.out:
 - `../tomcat/logs/catalina.out`
 - Client shell log:
 - `C:\Documents and Settings\<user>\Application Data\QAD\Shell\QAD.Applications.log`

Trouble Shooting Aids: Informational Commands

Other Troubleshooting Aids

- Some additional informational commands
 - TOP - VSAR - GLANCE - VMSTAT
 - Windows Task Manager
 - GSW Admin Monitor
 - `ps -ef` or `ps -elf`
 - `wtbman -name [broker] -query`
 - `asbman -name [broker] -query`
 - `nsman -name NS1 -query`
 - WebSpeed Messenger Admin Utility - ping
 - Connection Manager status
 - ?

Troubleshooting Exercise

Troubleshooting Exercise

- Bad news – All of your users report they can't get into their QAD .NET UI systems
 - Use your bag of tricks to determine and correct the cause of their problems
 - Be sure to test all functionality of QAD .NET UI before giving them the go-ahead
- As always happens, they have a few more complaints, even after your heroic efforts to get the system up and running

Knowledge Check

- 1 When databases are bounced, which services need to be restarted?
- 2 Which two commands do you use to test the Admin and Name servers?
- 3 How do you test WebSpeed Messenger?
- 4 What is the purpose of the `tail` command?
- 5 Where are the AppServer and `catalina.out` logs located?

Chapter 8

Customizing Browsers

Chapter Objectives

Chapter Objectives

- The objective of this chapter is to describe how to use
 - Browse Maintenance
 - Browse Link Maintenance
 - Browse URL Maintenance

Benefits

Benefits

- You will be able to use the Browse Maintenance programs to customize your browsers

Training Flow

Training Flow



- Overview
- Terminology
- Components
- Administration Tasks
- Multiple Systems
- Performance Tuning
- Troubleshooting
- **Customizing Browsers**
- Menu and Browse Collections
- Process Maps
- Configurable Screens

Browse Maintenance

Browse Maintenance

- Design tool for creating, editing, duplicating and deleting browses
- .NET UI program for non-component based browses
- Customize field properties
- Create table joins
- Import and export browses

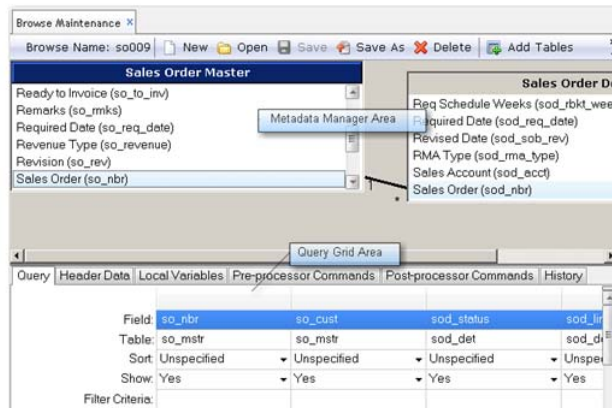

ADM_8CLUS_050

Use Browse Maintenance (36.4.8.13) to specify the components of a browse. The storage of the browse definition is performed automatically.

All browses created by Browse Maintenance (.NET User Interface) can be maintained in the Character UI.

There is no limit to the number of tables you can include using the .NET UI Browse Maintenance, but including more than 30 tables in a browse definition can cause the .NET UI browse engine to halt. The browse engine was originally designed with a four-table limit to avoid Progress performance issues. The Character UI browse engine and Desktop browse engine have four-table limits.

Creating a Browse

Creating a Browse

- Add left and right tables
- Include or exclude system tables
- Can include up to 30 tables in a new browse
- Tables defined in `clientsession.xml`
- Restricted tables are not displayed

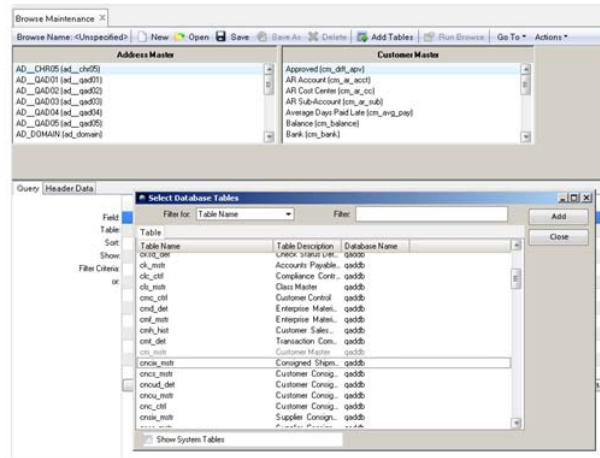

ADM_&CUS_0.60

When you start Browse Maintenance, the function is ready to create a new browse.

Click the Add Tables icon in the tool bar to display the Select Database Tables window. Double-click the name of the table you want to add as the left table, and then double-click on the name of the table you want to add as the right table.

In the Select Database Tables screen, the Show System Tables field ensures that system tables (such as *_Db, *_File, and *_Field) are displayed (or not displayed) in the table list.

The tables displayed for each program are defined in the `client-session.xml` file. The Browse Maintenance function reads this .XML file before populating the Select Tables screen. You can prevent tables from being displayed by modifying this file.

Selecting Fields

Selecting Fields

- Right-click Table Area
- Select or deselect custom QAD fields

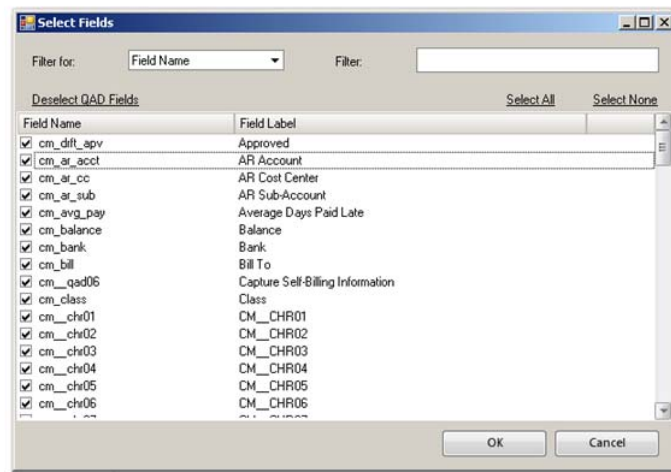

ADM_8CUS_070

Right-click the table area and choose Select Fields. The Select Fields dialog has the following constraints:

- A field used in a table join cannot be unchecked and is displayed as grayed-out text in the dialog field list.
- A minimum of one field must be checked in the dialog field list before clicking OK to exit the screen.

When you have selected a subset of fields for a table, only the selected fields are displayed in the table control area. Note the filter icon displayed in the upper right corner of the Table Control to indicate to the user that a filtered list of fields is being displayed.

Using the Query Tab

Using the Query Tab

- Add fields to the browse using the Query tab
- Set field Sort and Include properties
- Set field filters
- View and modify field properties

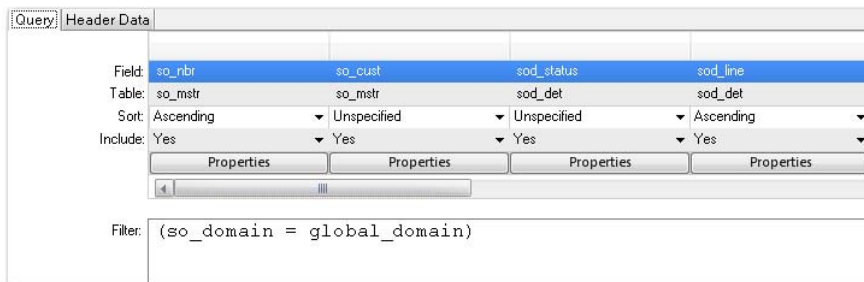

To add a field from a table to the browse, drag-and-drop a field from the table to a column in the Query section. Note that you can view and modify the properties by clicking on the Properties button at the bottom of the column.

To insert new blank columns into the grid, right-click the column header to display the column options.

Field Properties

Field Properties

- Specify a label term from the label master table
- Sort order if column is set to Ascending
- Expressions for local variables
- Data Types for local variables
- Format depends on data type
- Display length

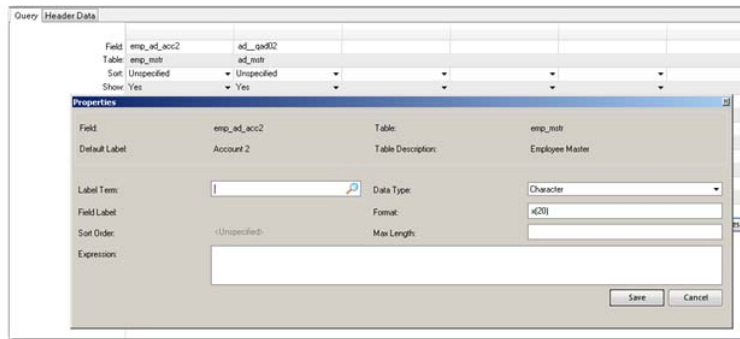

ADM_&CUS_090

The label term field specifies the key or label term from the label master table which is used to retrieve the field label displayed in the column in the browse results.

When saving the browse definition:

If the label term does not exist in the label master table, the system creates a new label master record using the string entered (the string is set to all uppercase and spaces are replaced with underscores).

The new label master record's value is the entered label term. For example, if you enter the new term Red Book, the label master table is queried and the term is not found. A new label master record is created with the key RED_BOOK and the value Red Book. An associated lookup lets the user select an existing label term from the label master table.

Header Data Tab

Header Data Tab

- Name and description for the browse
- Optionally restrict access to the browse
- Join the browse tables to the global domain
- Specify the value returned by double-clicking on a browse row



ADM_B&CUS_100

Roles in Enterprise Edition are the equivalent of user groups in Standard Edition. You use the same User IDs/Groups field to define access to browse functions in both applications.

If your role or user group has not been specified in the User IDs/Groups field on the Header Data tab, you can run the browse but cannot open the browse in Browse Maintenance. You can also specify roles or user groups in the authorized user list for the Browse Maintenance Import, Export, and Multiple Delete functions.

Other Browse Options

Other Browse Options

- Local Variables
- Pre-Processor Commands
- Post-Processor Commands
- Browse History

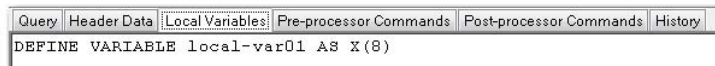

Right-click the Header Data tab to select which additional tabs you want to display: Local Variables, Pre-processor Commands, Post-processor Commands, and History tabs.

The Pre-processor Commands and Post-processor Commands tabs are available only for backwards compatibility with browsers defined using the Character UI. These tabs provide a way to enter Progress 4GL code that can run either before (pre-processor) or after (post-processor) the browse runs. You do not need to use these tabs when creating a new browse using the QAD .NET UI.

The History tab displays revision history for this browse.

By default, only the Query and Header Data tabs display.

Performance Considerations and Limitations

Performance Considerations and Limitations

- 200-character limit restricts the number of parameters in browse links
- Check the number of records that will be retrieved by the browse
- Check that fields have been properly indexed
- 30-table limit in browses
- Character UI and .NET browse compatibility



ADM_BCUS_120

A browse on a database table that has a great many records may take a long time to save and hours to run. System resources are also strained when you select fields as search criteria that have not been properly indexed.

You should, therefore, consult the data dictionary before defining a browse, to check the number of records being retrieved by a browse. You should also check that the selected fields have been indexed.

There is no limit to the number of tables you can include using the .NET UI Browse Maintenance, but including more than 30 tables in a browse definition can cause the .NET UI browse engine to halt. The browse engine was originally designed with a four-table limit to avoid Progress performance issues. The Character UI browse engine and desktop browse engine have four-table limits.

Although all browses created by Browse Maintenance (.NET User Interface) can be maintained in the Character UI, some legacy browses defined using the Character UI might not be maintainable by Browse Maintenance (.NET User Interface). In the Character UI, you create a browse by entering data in two maintenance programs: View Maintenance and Browse Maintenance. You have to enter the join data in View Maintenance's Join Phrase field, where *join data* is a clause of the form:

```
<from table>.<from field> = <to table>.<to field>
```

However, more than just join data can be entered in View Maintenance's Join Phrase field. For example, you can include field filters of the form `<field name> <operator> <value>`. Browse Maintenance (.NET User Interface) only supports maintaining join data.

Browse Performance Controls

In QAD .NET UI 2.9.3.79 (2011.1 EE), if a browse runs longer than five minutes, the browse will be cancelled and the user will get a browse timeout message.

When developing custom browses with Browse Maintenance, be sure to follow the browse performance guidelines described in *User Guide: Introduction to QAD Enterprise Applications*. If not developed carefully, custom browses can cause performance issues.

If custom browses are causing performance issues, you can configure the system to identify those browses, send warnings to the Message Inbox, and cancel the browses after a specified time.

Cancelling the browses after a specified time prevents long-running browse queries from adversely affecting application server performance, which can affect all the users of the system. You can have the system identify, report, and eventually cancel long-running browses. You can alert administrators that a performance problem could be developing by having the system periodically send messages to the Messages Inbox.

The browse name and query conditions are included in the messages to help administrators identify problematic browses and their user-specified conditions. In general, performance issues can often center around just a few browses. To track particular types of browses, you can use regular expressions to specify the names of the browses you want to monitor and possibly cancel after some specified time. To configure the system to identify, report, and cancel such browses, use the following settings in the client session configuration file (`client-session.xml`):

- `<NotifyRole>` indicates which role (or group) of users gets notified on any browse alert. Notification is sent to the Messages Inbox. If blank, no notification is sent to administrators, but the user running the browse gets a browse timeout message.

`<timeout browseId="browse_name" warnAt="interval" cancelAfter="interval"/>` specifies a browse performance warning or cancellation, where:

- `browseId` specifies a browse name (such as `ppbr100.p`) or a regular expression (such as `so*`) to specify browse names. The default is blank, which applies the browse performance warnings to all browses.
- `warnAt` specifies the interval for sending warning messages to users in the `<NotifyRole>` role (or group). The warning messages can alert administrators that a performance problem could be developing because of a long-running browse query. The messages include the browse name and the query conditions entered by the user.
- `cancelAfter` specifies the minutes after which the browse will be cancelled, with 0 specifying no cancellation.

Use `warnAt` and `cancelAfter` to have the system report warnings up to some time after which the browse is cancelled automatically. For instance, in `<timeout browseId="xx*" warnAt="2" cancelAfter="5"/>`, the system reports warnings two minutes for all browses running whose names start with `xx`. After five minutes, those browses are cancelled.

The following is included in `client-session.xml`:

```
<Browse>
  <Notification>
    ...
    <NotifyRole></NotifyRole>
    <timeout browseId="" warnAt="0" cancelAfter="5"/>
    ...
    <!-- Add additional specific browse setting as required
    <timeout browseId="ppbr100.p" warnAt="2" cancelAfter="5"/>
    <timeout browseId="so*" warnAt="2" cancelAfter="5"/>
    -->
    ...
  </Notification>
</Browse>
```

Important The browse performance settings are active by default. If a browse runs longer than five minutes, the browse is cancelled and the user gets a browse timeout message.

Table Joins

Table Joins

- Drag and drop to create a join
- View and modify join properties
- Datatype conversion
- Inner and Outer Joins

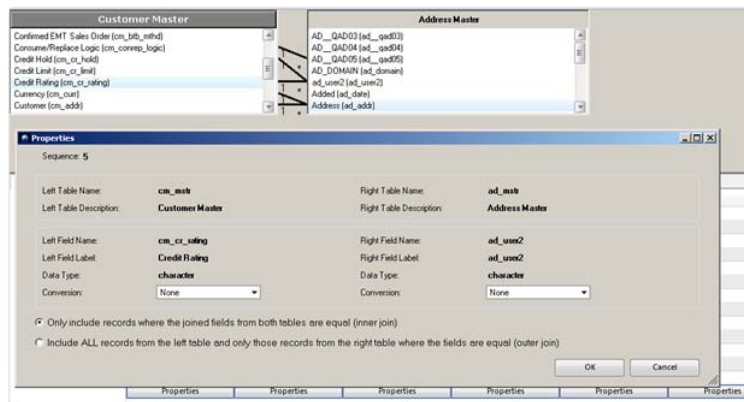

ADM_&CUS_130

An inner join returns the records selected for the first table combined with related records selected from the second table. If a record does not exist in the second table, no records are returned. Only related records selected from both sides of the relationship display in the view.

An outer join returns the records found by an inner join. However, in addition, for each value in the first table, it returns unknown values from the second table when no related record is found. As a result, all matching records from the first table are preserved for unmatched records in the second table.

The default join type is inner. Using the outer join can give you more flexibility in displaying information.

Example An inner join between customers and sales orders displays only customers with sales orders. An outer join includes all customers, even those who do not have orders.

Importing Browsers

Importing Browsers

- Select a browse definition file (.brwx) using the Open lookup

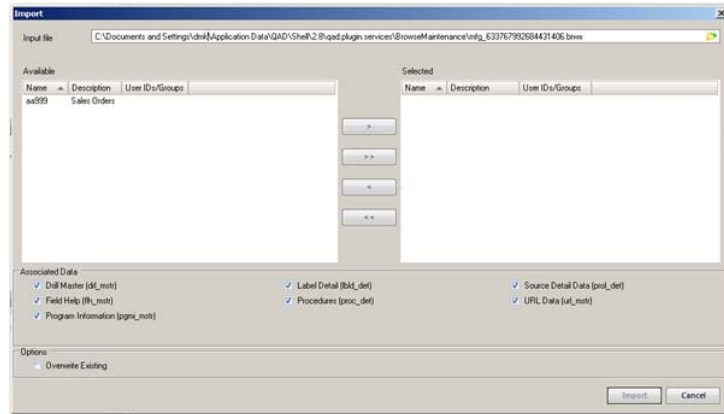

- Specify the data to import using the Associated Data options



ADM_8CUS_1-40

Importing includes the browse and view data for the browse, but you can specify whether to include associated browse data in the Associated Data pane, which includes checkboxes for including the Drill Master, Field Help, Program Information, Label Detail, Procedures, Source Detail Data, and URL Data.

If you are importing a browse that has the same name as an existing browse, specify whether you want the system to replace the existing browse with the one you are importing by choosing the Overwrite Existing checkbox in the Options pane. Finally, click the Import button.

The Import and Export functions requires that you are using Progress version 10.1C01 at a minimum.

Exporting Browsers

Exporting Browsers

- Select a .brwx file to display available browsers
- Use the Associated Data options to limit the data to be exported
- Browsers are exported to a default location:
 - C:\Documents and Settings\username\Application Data\QAD\Shell\version\qad.plugin.services\BrowseMaintenance



ADM_BCUS_150

The ability to export, import, and delete browsers is disabled by default and should be limited to authorized users.

Do this by configuring a setting in the `client-session.xml` file located in:

```
TomcatInstallDir/webapps/qadhome/configurations/SysEnv/
```

The `<DotNetBrowseMaintenanceUtilities>` element includes a `<Utility>` element whose attributes specify authorization the import, export, and delete features.

Deleting Multiple Browses

Deleting Multiple Browses

- Security considerations
 - Restrict the use of Browse Import, Export and Multiple Delete functions by modifying the `clientsession.xml` file

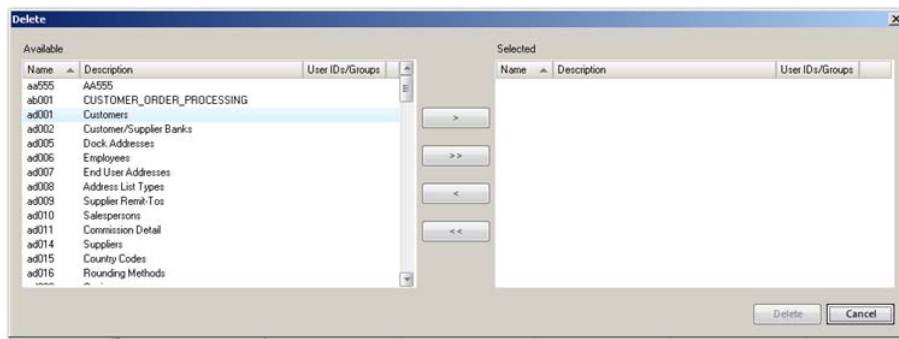

ADM_BCUS_1.60

Deleting will remove the browse and view data along with the associated data.

Browse Link Maintenance

Browse Link Maintenance

- Specify program links as URLs that display as buttons on browses
- New and Edit links display as Create and Modify buttons
- Data in the current browse is passed to the linked Modify program
- Links loaded during install for many browses

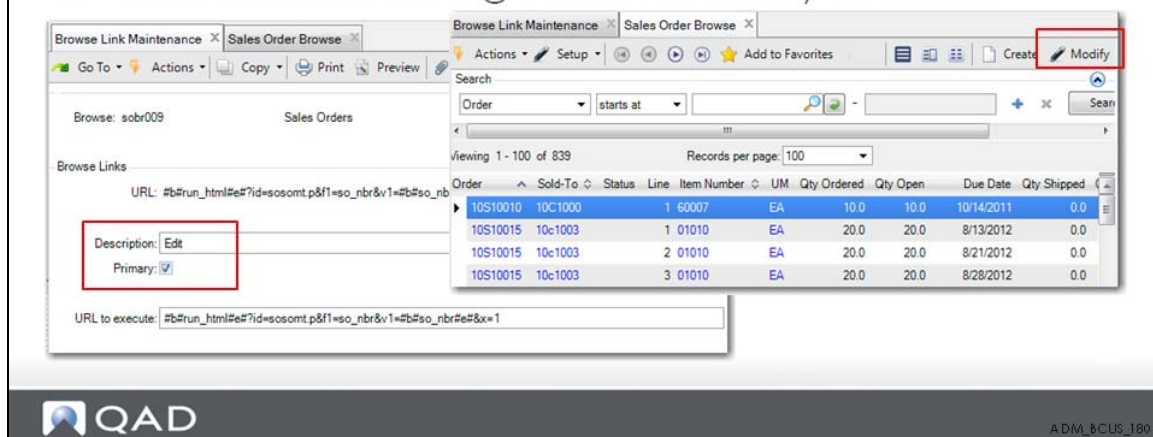

You can use Browse Link Maintenance to associate programs with a browse that display as buttons on the browse toolbar. Link data has already been defined for most commonly used browses so that Create and Modify buttons display when the product is installed.

Note When buttons are defined with a description of New and Edit in Browse Link Maintenance, the terms are mapped to Create and Modify for display on the toolbar.

When you click the button in a browse, data from the currently selected row in the browse is passed to the linked program.

For example, in Sales Order Browse, click Create to open Sales Order Maintenance to enter a new sales order. Click Edit to open Sales Order Maintenance to modify the order for the currently selected row in Sales Order Browse.

If needed, you can define additional associations to commonly used programs that will also appear on the browse toolbar labeled with the text you supply in the Description field.

Creating a Browse Link

Creating a Browse Link

- Select a browse
- Specify the program link as a URL to Execute, using the syntax:
 - `#b#run_html#e#?id=program_name`
- Set the HTTP parameters for the program
 - Index is the number of submits the program executes
 - Field and Value are the field and value you want to load in the linked program



ADM_BCUS_190

The index field is used to store the number of times the program will execute an Enter action (similar to pressing the Next button).

In simple maintenance programs, this is set to 1 to simply enter the key field values and access the fields that can be maintained in the linked record. More complex maintenance programs may have multiple sets of input prompts to be processed to access the frame of maintainable data.

For example, the first prompt for data in `addkmt.p` requires a value for the field `Shipto`. The program link record provides the value of `ad_ref` from the browse and executes the first Enter action.

The next prompt for data in the maintenance program requires a value for the field `ad_addr` and the browse link provides the value of `ad_addr` from the browse and executes a second Enter action. This advances the maintenance program to its frame of maintainable data for the user. Each time the program asks for data to be entered, the browse link logic offers up the fields it has and if the field names it has data for matches one of the fields the program is looking for, the field value is provided and an Enter action is executed (if any are left to execute).

Use the Field field to enter the name of the variables that the target program is using to prompt for data. This information can be found by executing the program, advancing the cursor to a field of interest, and pressing Ctrl+F.

The value fields (Value[1], Value[2], and so on) are the variable names from the browse providing the data and must be contained within #b# and #e#. The browse link logic uses these tags to parse out the value of the field from its record buffer.

Example

Field[1]: shipto; Value[1] : #b#ad_ref#e#

Field[2]: ad_addr; Value[1] : #b#ad_addr#e#

Important Progress has a limit in the size of the data that can be stored in an index. In versions prior to 10.1B, the limit is around 200 characters (the sum of all the data contained in the fields of an index of a record). This limit has been increased to around 2000 characters in version 10.1B and beyond. Within browse link functionality, you are restricted to the 200-character limit unless you have upgraded your version of Progress. This limits the number of parameters that can be defined in a browse link, usually to four or less, although a fifth parameter is possible if the names of all of the involved fields are small.

Exercise

Exercise



Browse URL Maintenance

Browse URL Maintenance

- Create links to:
 - Programs
 - External Web sites, such as supplier or customer company Web sites,
- Create URL links for specific records in browse cells



ADM_BCUS_210

When a browse cell contains a URL link, double-clicking it launches a new browser window and displays the intranet or Internet resource associated with the URL. You can use these URLs in two ways:

- Create links to external Web sites that users can activate from QAD .NET browses, such as a supplier Web site associated with a supplier ID.
- Create links to other programs and pass specific data values to the programs. This lets you use browses as a means of navigating directly to maintenance programs.

You can access links to other programs only from drill-down browses, not lookups. Drill-down browses are typically available directly from the menus, but can also be associated with program fields in Drill Down/Lookup Maintenance (36.20.1 in SE, 36.4.8.1 in EE).

Creating a Browse URL Link to a Program

Creating a URL Link to a Program

- Using run_html to build the URL
- Specify:
 - The program
 - The field and value
 - The index
- Use the syntax
`#b#run_html#e#?id=program_name&f1=field_name&v1=value_name#b#`
- Set the HTTP parameters for the program
- Field and Value are the field and value you want to load in the linked program



ADM_BCUS_220

Example For example, you can set up links in an item browse to directly access Item Master Maintenance (1.4.1), passing the current item number to the maintenance program, and executing the Next command any number of times. When a user clicks the link, Item Master Maintenance displays in a detached window. Multiple columns of data in a browse can contain links so that you can access maintenance programs for any data related to a record. However, data for only one field can be passed to each program.

Exercise

Exercise



Creating a Browse Link to a Web Page

Creating a Browse Link to a Web Page

- Specify:
 - The browse
 - Field name and value
 - The URL
- Use the syntax: `http://www.website.com`



ADM_B_CUS_240

Example You want to establish a URL link in the Purchase Order Browse from supplier ID GS10100 to the corresponding supplier's company Web site, located at:

<http://www.generalsupplies.com>.

Enter these values in Browse URL Maintenance:

Field Name	Value
Browse	pobr006.p
User ID	*
Field Name	po_vend
Value	gs_10100
URL	http://www.generalsupplies.com
Description	General Supplies Web Site
Primary	Yes

When you run Purchase Order Browse, the supplier gs_10100 record now features a link to the Web site www.generalsupplies.com.

Exercise

Exercise



Creating a Browse Link to a Record

Creating a Browse Link to a Record

- Insert a string in the URL that is replaced by a browse field value
- You can create a link to a specific field at a web address, for example, a catalog item
- Insert the field name in the URL
- Use the syntax:

```
http://www.website.com/catalog/#b#fieldname#e#
```



ADM_BCUS_260

URLs can contain special strings that are automatically replaced by field values in the browse. Selecting a link containing this type of string automatically replaces that string with the corresponding field value in the row. Follow these steps to define this type of special string in a URL:

- 1 Enter #b# to indicate the beginning of the string.
- 2 After the #b#, enter a field name associated with the specified browse.
- 3 Enter #e# to indicate the end of the string.
- 4 The Web site for one of your primary suppliers contains a catalog of items. Entering an item's identifier at this Web site accesses the catalog entry for that item, containing information such as item cost, quantity available, and ship weight. To create links from the supplier item numbers to their corresponding catalog entries at the supplier's Web site, create the following URL: `http://www.generalsupplies.com/catalog/#b#vp_vend_part#e#`
Note You must include `http://` in the URL. For example, you must use `http://www.generalsupplies.com/` and not just `www.generalsupplies.com`.
- 5 Next, associate the URL with the Supplier Item column in the Supplier Item Browse.
- 6 After you establish this link, selecting a supplier item number in the Supplier Item Browse automatically inserts the selected field value. For example, selecting supplier item 10-1005 creates this URL: `http://www.generalsupplies.com/10-1005`.

- 7 The system then launches a Web browser to display the relevant catalog information for that item located at that URL address.

Knowledge Check

- 1 What is the recommended upper limit of tables you can include in a browse definition?
- 2 How do you restrict access to the Browse Import and Export functions?
- 3 What information should you check before creating a browse?
- 4 What is the file extension for browse definitions?
- 5 Which menu do you use to associated drill-downs with fields?

Chapter 9

Menu and Browse Collections

Chapter Objectives

Chapter Objectives

- The objective of this chapter is to introduce the Menu Collection and Browse Collection programs.

Benefits

Benefits

- You will be familiar with the Collections functions.

Training Flow

Training Flow



- Overview
- Terminology
- Components
- Administration Tasks
- Multiple Systems
- Performance Tuning
- Troubleshooting
- Customizing Browsers
- **Menu and Browse Collections**
- Process Maps
- Configurable Screens

Menu Collections

Menu Collections

- Collections of menu items such as programs, browses, process maps, and dashboards
- Stored in the Collections folder
- Need access to Administration Menu

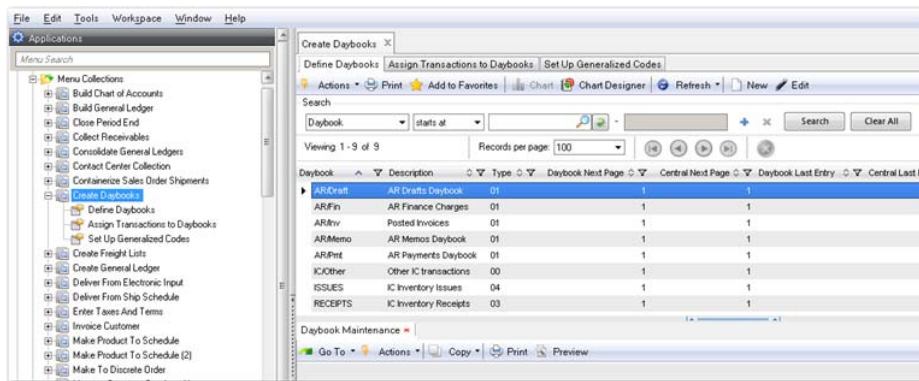

Menu Collection Maintenance

Menu Collection Maintenance

- Drag-and-drop facility for adding menus to collections
- Set the order of menus in the collection using the up and down arrows

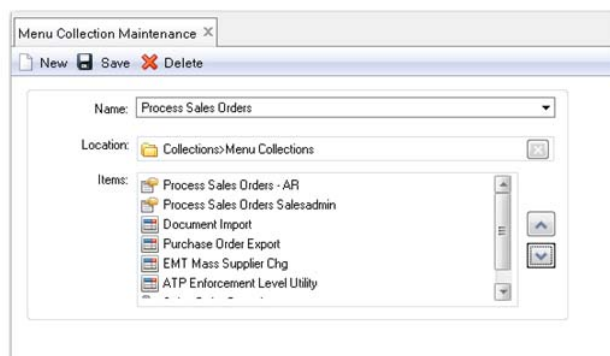

Browse Collections

Browse Collections

- Browse Collections comprise a main browse that can drive selected fields in other browses and programs
- Can be customized and saved to user favorites
- Can link to
 - Other browses
 - Maintenance and report programs
 - Other URLs such as external Web pages
- Need access to Administration Menu



ADM_COLL_070

There is no limit to the number of programs and browses you can include in a Browse Collection. However, when defining the collection, you should consider that a large collection takes longer to display on the screen, and there may be a performance issue if it is to be in constant use by a large number of users. In this case, you should consider multiple smaller collections.

Browse Collection Maintenance

Browse Collection Maintenance

- Main browse in upper half of screen
- Related browses and programs in lower half

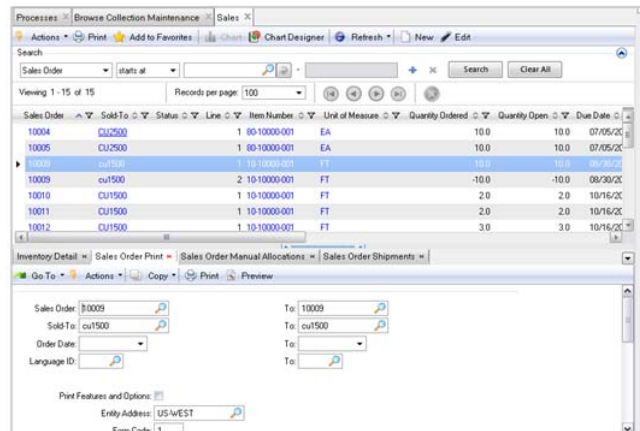

Browse Collection Maintenance

- Give collection a Name
- Assign Location in menu

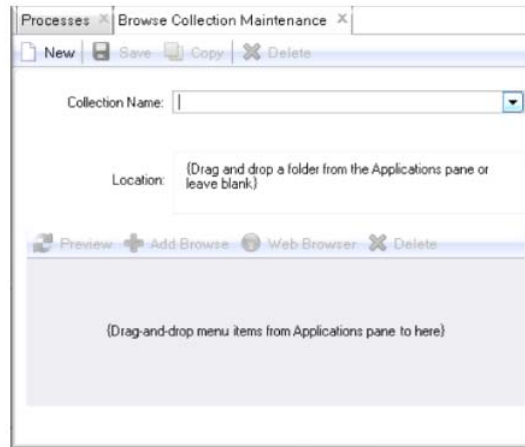

Browse collections are stored in the Collections folder in the Applications area. When you right-click the Collection name and select Design, you can open the collection directly in Browse Collection Maintenance. This option lets you modify collection properties from the desktop without having to run the maintenance program.

Browse Collection Maintenance

- Select Main Browse and related browses / programs and links between them

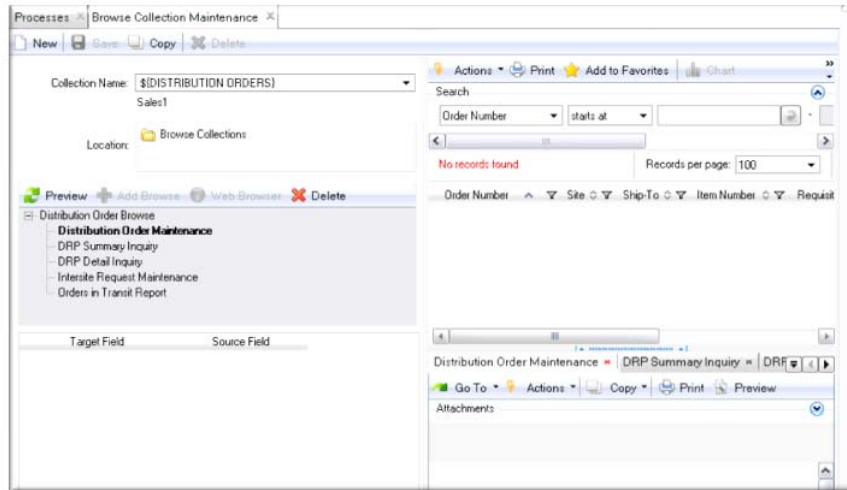

ADM_COLL_100

You can specify a label term as a name for the browse collection. The advantage of doing this is that you can use a label term whose associated description has been translated into a supported language. To find an existing label term, open Label Master Browse (36.4.17.2). To quickly find a label term you might want to use, use the browse's Search function. For example, if you want to find a label term that includes `Item`, set the Search fields to `Term contains Item` and click Search.

In the browse, the `Term` column lists the label terms that include `Item` and the `Long Label` column displays the associated descriptions. Next, in Browse Collection Maintenance's Name field, enter the label term in the format `${Term}`.

Important You must use curly brackets `{ }` when defining a label term. Otherwise, the label will not link correctly to the translated description.

For example, if the label term is `ALL_ITEMS`, enter `${ALL_ITEMS}` in the Name field. After the browse collection is saved, in the Applications Pane, the browse collection name takes the description associated with the `ALL_ITEMS` label term.

If the `${Term}` name is not converted immediately to the label term's description, log out and log back in again to refresh the Application area's display.

Running Browse Collections

Running Browse Collections

- Selecting a row in the main browse changes linked data in the programs in the collection

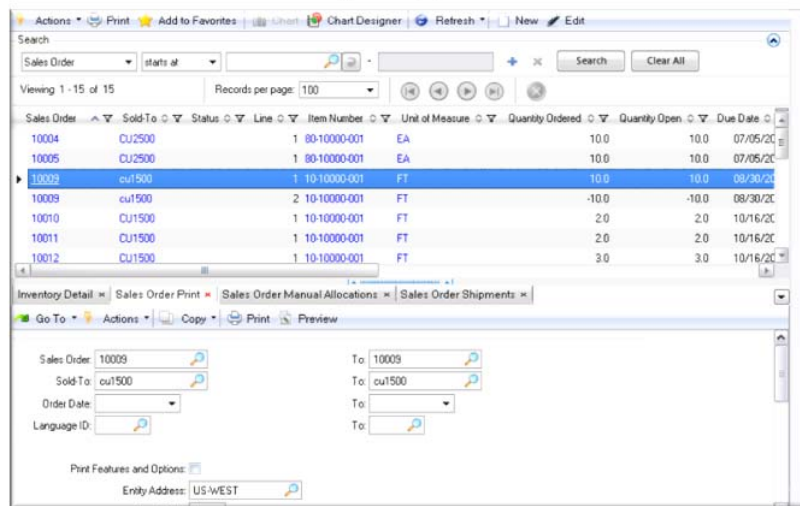

ADM_COLL_110

You can also drive URLs from browses. For example, select Customer Address Browse and click the Web Browser button.

- 1 In the Title field, enter Google Address Search. In the URL field, enter `http://maps.google.com/maps?q=` and then choose Postal Code from the pull-down menu, which adds `<Postal Code>` to the Google Maps query. Now Customer Address Browse automatically drives a Google Maps query.
- 2 If you decide you want to remove one of the browses or programs, select the browse or program and click the Delete button just above the gray area.
- 3 To preview the collection, click Preview.

Knowledge Check

- 1 Where are menu and browse collections located in the Applications area?
- 2 How do you edit a browse collection directly from the Applications area?
- 3 How many fields can be used as target fields?

Chapter 10

Process Maps

Objectives

Objectives

- Understand process maps
- Edit process maps
- Administer process maps

Benefits

Benefits

You will be able to:

- Create your own process maps
- Link process maps to menus and operational metrics

Training Flow

Training Flow



- Overview
- Terminology
- Components
- Administration Tasks
- Multiple Systems
- Performance Tuning
- Troubleshooting
- Customizing Browsers
- Menu and Browse Collections
- **Process Maps**
- Configurable Screens

Overview

Process Maps

- A process is a structured set of activities designed to accomplish a specific objective
- Process maps illustrate principal business and operational processes within a QAD application and provide graphical navigation
- Two separate views for process maps in QAD applications
 - Vertical Industry View
 - Supply Chain View
- Both views lead to the same detailed maps

Process Maps Views

Process Maps Views

- Vertical Industry



- Supply Chain



Naming Conventions

Naming Conventions

- Each map has a title
- Label keys {...} defined in Process Label Maintenance
- Alternatively, enter text in Process Editor's Title field
- Best practice is to use label keys

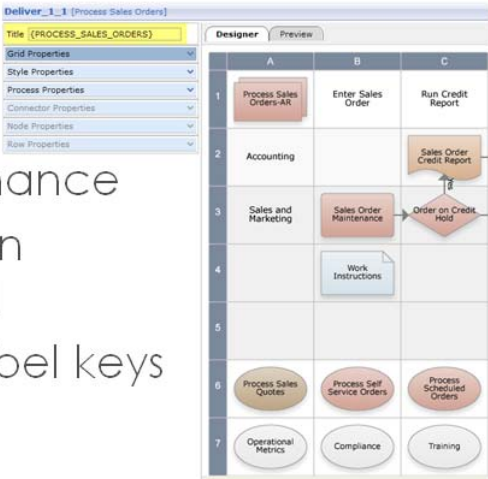

Numbering Conventions

Numbering Conventions

- A code identifies the functional area to which the map belongs
- A number indicates the map's place within the map hierarchy for that area
- Example

- The first map in the Automotive area is named Auto_1
- Auto_1 opens four submaps named Auto_1_1, Auto_1_2, Auto_1_3, and Auto_1_4
- Two maps open from Auto_1_2 named Auto_1_2_1 and Auto_1_2_2
- One map opens from Auto_1_2_1 named Auto_1_2_1_1

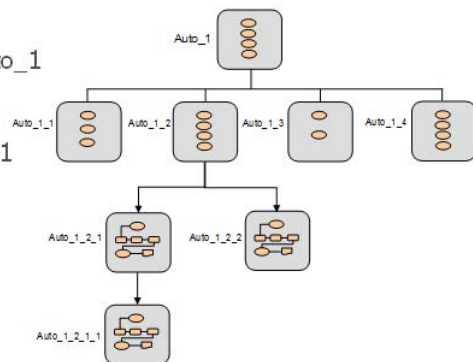

Map Titles

Map Titles

- Level 1:
High-level vertical map for that area; title in black text above the map
- Level 2:
Subsequent vertical map, or a detailed process flow

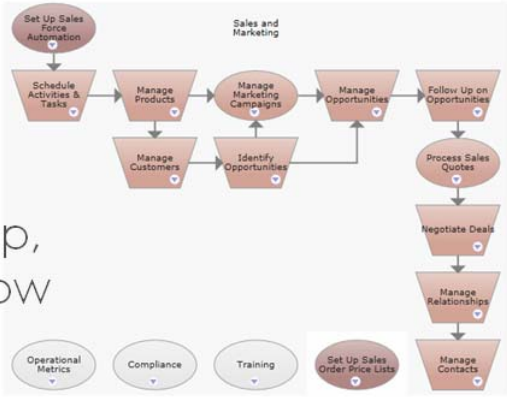

Breadcrumbs

Breadcrumbs

- Shows path to current map
- Navigate back by clicking on each breadcrumb

Supply Chain Process Model > Set Up Chart of Accounts Structure (EF) > Set Up Daybooks (EF)
Set Up Daybooks (EF)

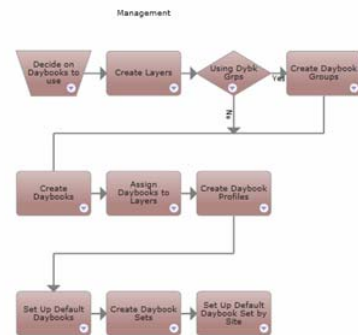

Nodes

Nodes

- Menu Item
 - Indicates a link to a program on the menu
- Other Process Map
 - Connects activities on one process map to another process map
- Menu Item Collection
 - Links to collections
- Manual Step
 - Tasks performed outside of the QAD application, for example, external planning
- Decision
 - Directs the flow of a map when it can branch in two directions

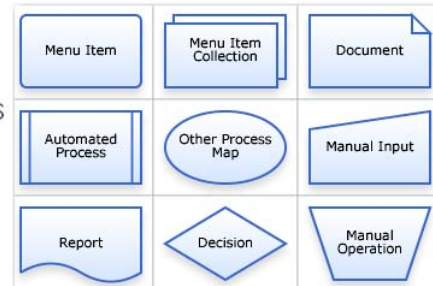

Nodes

- Document
 - Represents reports or files, such as Word documents or Excel spreadsheets, relevant to a task
- Manual Input
 - Indicates inputs to the process from external systems or outputs to external systems, for example, Electronic Document Interchange (EDI)
- Automated Process
 - Indicates a link to an automated process
- Report
 - Indicates a link to a report program
- Nodes also indicate a user's permissions to the link: If the user does not have access, the node grays out

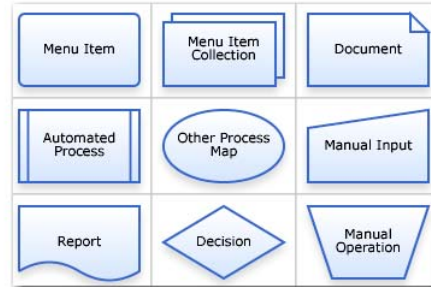

Viewing Process Maps

Viewing Process Maps

- Use the Process Editor to view maps

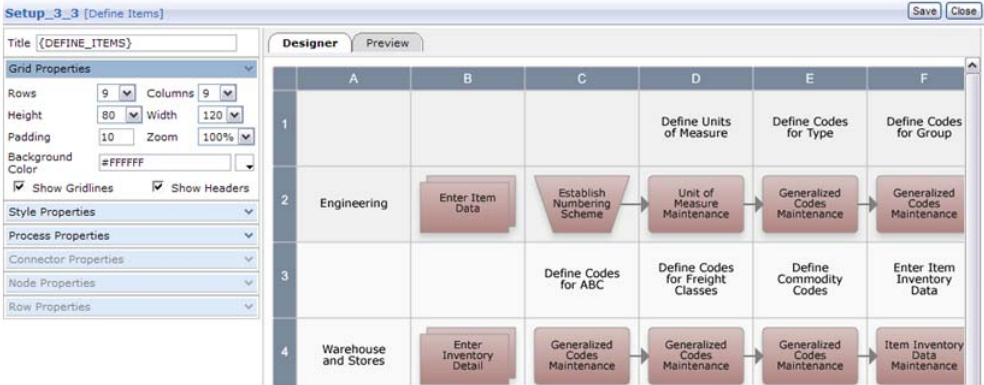

- Click Open to select existing process maps

Viewing Process Maps

- Process maps are rendered using Microsoft's **Silverlight** technology
- Silverlight is a programmable Web browser plugin compatible with .NET applications
- Can also be viewed using standard **SVG**-based technology
- The scalable vector graphics (SVG) format is an XML technology for defining vector-based two-dimensional graphics for the Web
- Set the default display technology in Process Admin Context Parameters



ADM_PMAP_140

Note Adobe Scalable Vector Graphics (SVG) Viewer is not supported by Adobe Systems. If the SVG plugin does not correctly install automatically, you must install it manually.

Creating a Process Map

Creating a Process Map

- Click New to create a new map
- Assign a name, title, and owner (do not use spaces)
- Use Grid Properties to set:
 - The number of rows and columns,
 - cell height, width, and padding
 - A zoom factor for previewing purposes
 - Cell background color
 - Cell gridlines and header settings

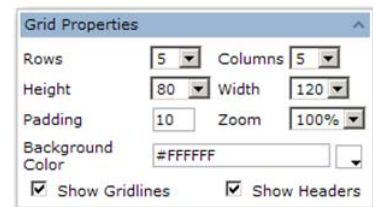

Editing Style Properties

Editing Style Properties

- Styles are pre-defined and are applied to nodes
- You can edit the default font and node properties for the style
- Style attributes are stored in process-config.xml
- Changes you make to styles do not affect existing process maps in which the style is used

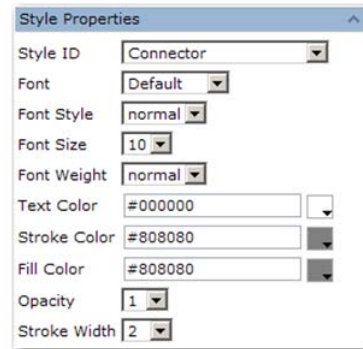

Process Map Variables

Process Maps Variables

- Used to create links from the Editor to programs, images, icons, other nodes, operational metrics, ..
- Variables ensure that processes can be used in multiple environments
- System global variables are displayed in the Process Properties dialog and defined in the Process Administration dialog
- You can also define local variables with this dialog

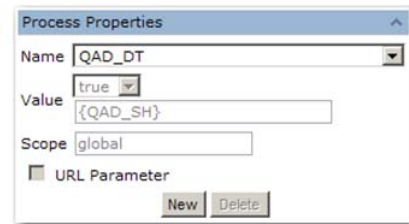

Connector Properties

Connector Properties

- Available when you select an inter-node connector
- Define properties for arrows and lines
- Apply a label or link the connector to a program, other process map, or file
- If the connector is linked, specify the target window
- Set the shape, style, and dash width

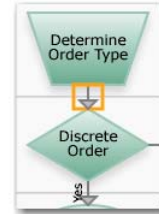

The screenshot shows a dialog box titled "Connector Properties". It contains the following fields and controls:

- Label:** A text input field.
- Link:** A dropdown menu.
- Target:** A dropdown menu with "Current Window" selected.
- Shape:** A dropdown menu with "Top Elbow Arrow" selected.
- Style:** A dropdown menu with "Connector" selected.
- Dash Width:** A text input field with the value "0".

Node Properties

Node Properties

- Available when you click a cell in the grid
- Use to design nodes
- Set a label and tooltip, which use the default attributes defined in the style
- Link to a file, program or another node
- The system uses process variables to locate files, programs, or process maps to be linked
- Target lets you open the link in the current window or new window

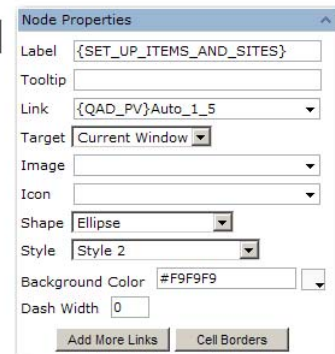

The screenshot shows a 'Node Properties' dialog box with the following fields and values:

- Label: {SET_UP_ITEMS_AND_SITES}
- Tooltip: (empty)
- Link: {QAD_PV}Auto_1_5
- Target: Current Window
- Image: (empty)
- Icon: (empty)
- Shape: Ellipse
- Style: Style 2
- Background Color: #F9F9F9
- Dash Width: 0

Buttons at the bottom: Add More Links, Cell Borders

Node Properties

- Display an image instead of the default node shape
- The image sized to fit the cell
- Select an icon to display in the lower right-hand corner of the node
- Select the node shape, based on the function of the node in the process map
- Select a style for the node, from the default styles defined in Style Properties
- Set a background color

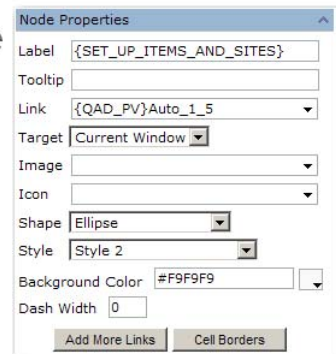

The screenshot shows a 'Node Properties' dialog box with the following fields and options:

- Label: {SET_UP_ITEMS_AND_SITES}
- Tooltip: (empty)
- Link: {{QAD_PV}Auto_1_5}
- Target: Current Window
- Image: (empty)
- Icon: (empty)
- Shape: Ellipse
- Style: Style 2
- Background Color: #F9F9F9
- Dash Width: 0

Buttons at the bottom: Add More Links, Cell Borders

Node Properties

- Dash Width is the length in pixels of dashed lines for the node border or for connectors
- Click Add More Links to add up to 8 additional URL links for the process map
- Click Cell Borders to define the color, width, and dash width of the cell borders

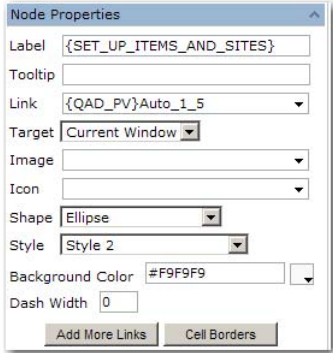

Process Map Administration

Process Administration

- Use the Process Admin option to set context parameters and define system properties variables

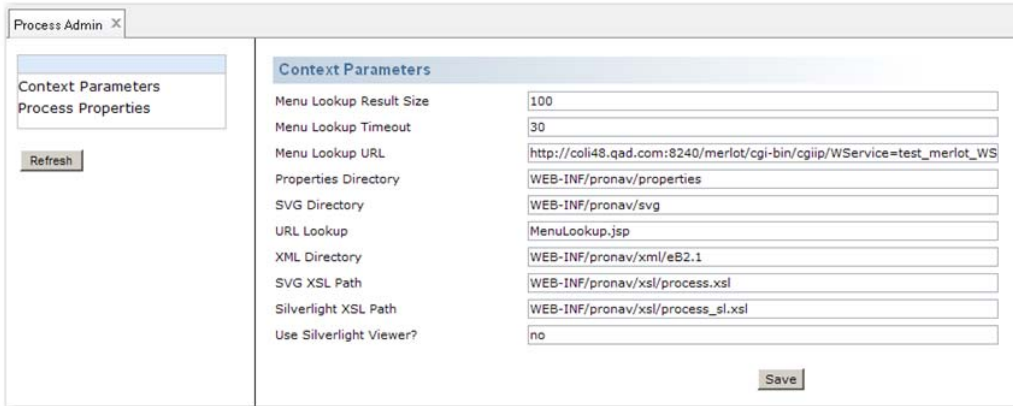

The screenshot shows a web application window titled "Process Admin". On the left, there is a navigation pane with two options: "Context Parameters" (selected) and "Process Properties". Below the navigation pane is a "Refresh" button. The main content area is titled "Context Parameters" and contains a list of parameters with their corresponding values in text input fields:

Parameter Name	Value
Menu Lookup Result Size	100
Menu Lookup Timeout	30
Menu Lookup URL	http://coli48.qad.com:8240/merlot/cgi-bin/cgiip/WService=test_merlot_WS
Properties Directory	WEB-INF/pronav/properties
SVG Directory	WEB-INF/pronav/svg
URL Lookup	MenuLookup.jsp
XML Directory	WEB-INF/pronav/xml/eB2.1
SVG XSL Path	WEB-INF/pronav/xsl/process.xsl
Silverlight XSL Path	WEB-INF/pronav/xsl/process_sl.xsl
Use Silverlight Viewer?	no

At the bottom right of the main content area, there is a "Save" button.

Context Parameters

Context Parameters

- Menu Lookup Result Size
 - The number of records returned when a user displays the Program Lookup associated with the URL field in Node Properties and Connector Properties
 - Default 100
- Menu Lookup Timeout
 - When a user uses the Program Lookup, the system connects to the active database using the URL specified in Menu Lookup URL and reads the menu information from the database
 - This information is held in memory for the number of minutes specified in this parameter

Context Parameters

- Menu Lookup URL
 - The full URL for connecting to a database to read menu records to display in the Program Lookup
 - For example
`http://crsu04.qad.com:4949/cgi-bin/qad_wspd_cgi_31c_dt91.ksh/WService=testdt91web.com/qad/nav/xmenu.p?Action=MenuLookup`
 - Built using the following elements
 - Relative path to the executables directory on the Web server
 - WebSpeed executable name
 - WebSpeed broker name
 - API for reading the database menus

Context Parameters

- SVG Directory
 - Specifies the directory path where the SVG files created with the Process Editor are stored
 - Path is relative to *TomcatInstallDir/webapps*
- URL Lookup
 - Specifies the file to use for generating the listing of programs associated with the URL field in Connector and Node Properties
 - By default, this is *MenuLookup.jsp*

Context Parameters

- XML Directory
 - The path to the directory where the XML files created with the Process Editor are stored
 - Path is relative to *TomcatInstallDir/webapps*
 - Process maps for each supported language are stored in
TomcatInstallDir/webapps/WEB-INF/pronav/xml
- SVG XSL Path
 - The path to the XSL file (installed with the system) used to convert process map files from XML to SVG format
 - Typically is *WEB-INF/pronav/xsl/process.xsl*
 - The path is relative to *TomcatInstallDir/webapps* directory

Context Parameters

- Silverlight XSL Path
 - The path to the XSL file (installed with the system) used to convert process files from XML to Silverlight format
 - Typically *WEB-INF/ pronav/xsl/process_sl.xsl*
 - Path is relative to *TomcatInstallDir/webapps*
- Use Silverlight Viewer
 - Use this option to set the default process map viewer
 - By default, this is Yes

Process Properties

Process Properties

- Use to display variables used by the Process Editor when creating maps
- Edit the default global variable definitions or create a new local variable
- Generally, you may only need to change the path for the QAD_DT_DOC_ROOT variable

Delete	Name	Value	Scope	URL Parameter
<input type="checkbox"/>	QAD_CONTENT	{QAD_DT_DOC_ROOT}/content/	global	<input type="checkbox"/>
<input type="checkbox"/>	QAD_CONTENT_IMG	/content/	global	<input type="checkbox"/>
<input type="checkbox"/>	QAD_DT	{QAD_SH}	global	<input type="checkbox"/>
<input type="checkbox"/>	QAD_DT_DOC_ROOT	/zinfandelEE	global	<input type="checkbox"/>
<input type="checkbox"/>	QAD_DT_IMG	{QAD_DT_DOC_ROOT}/images/	global	<input type="checkbox"/>
<input type="checkbox"/>	QAD_HOMESERVER	http://sql48.qad.com:8888/qad/zinfandel/	global	<input type="checkbox"/>
<input type="checkbox"/>	QAD_IMG	{QAD_DT_DOC_ROOT}/images/	global	<input type="checkbox"/>
<input type="checkbox"/>	QAD_IMG_DOCUMENT	{QAD_IMG}document.gif	global	<input type="checkbox"/>
<input type="checkbox"/>	QAD_IMG_MENUITEM	{QAD_IMG}table.gif	global	<input type="checkbox"/>
<input type="checkbox"/>	QAD_IMG_PROCESS	{QAD_IMG}process.gif	global	<input type="checkbox"/>
<input type="checkbox"/>	QAD_METRICS_IMAGE	{QAD_HOMESERVER}/configurations/<test>/storage/metrics_images/	global	<input type="checkbox"/>
<input type="checkbox"/>	QAD_PV	ProcessViewer.jsp?ProcessName=	global	<input type="checkbox"/>
<input type="checkbox"/>	QAD_SH	qadsh://menu/invoker/menuitem-alias=	global	<input type="checkbox"/>
<input type="checkbox"/>	QAD_SH_MENU_KEY	qadsh://menu/invoker/menuitem-key=	global	<input type="checkbox"/>

Language Support

Language Support

- The node Label field specifies the node text
- Each label has a key that identifies it
- Use Process Label Maintenance to maintain label keys and text in multiple languages
- Translated label text is stored separately to the node attributes
- Create a new label key for each new node
- Specify this key and its translated text for each required language

Process Label Maintenance

Process Label Maintenance

- Select a language from the drop-down list
- Translated text displays for each label key
- Translated labels are stored in the *properties_language.xml* file
- The system identifies the label text to display based on the label key and the user's language

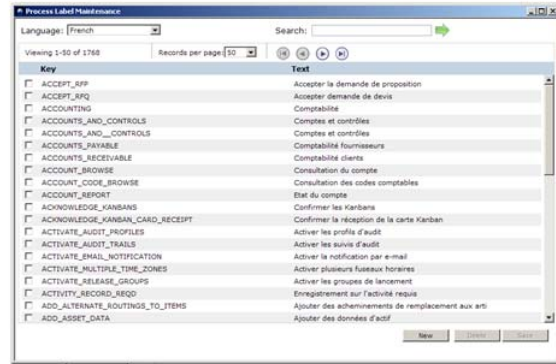

Managing Process Maps

Managing Process Maps

- Process maps are stored as XML files, for example, *FinanceEF_3_4.xml*
- These files are stored in
TomcatInstallDir/webapps/qadhome/configurations/default/storage
- When migrating to a new QAD .NET UI release, you must manually copy the map files to the *configurations/default/storage* directory of the new Web applications server

Knowledge Check

- 1 When a user does not have permissions for a program, how is this represented in the related process map?
- 2 In which menu do you set the default display technology?
- 3 In which file are the map style properties stored?
- 4 What is the purpose of the xml directory parameter?
- 5 Where are process maps stored?
- 6 What is the procedure for migrating process maps from one installation to another?

Chapter 11

Configurable Screens

Objectives

Chapter Objectives

- The objective of this chapter is to describe the Configurable Screens design function

Benefits

Benefits

- You will be able to customize non-component based programs using Configurable Screens features and functions

Training Flow

Training Flow



- Overview
- Terminology
- Components
- Administration Tasks
- Multiple Systems
- Performance Tuning
- Troubleshooting
- Customizing Browsers
- Menu and Browse Collections
- Process Maps
- **Configurable Screens**

Overview

Configurable Screens

- Design tool for configuring non-component based screens
- Equivalent to Design Mode for component-based screens
- Enabled for members of defined UI-design groups



ADM_CONF_050

Configurable Screens lets users in a designated UI design group disable fields for input, hide fields, set a predefined default value for a field, mark a field as required, add fields and frames, and set frame navigation.

Configurable Screens is used for non-component based programs only. Component-based screens are customized using Design Mode.

Note Access to the Configurable Screens functionality is enabled by the system administrator.

Types of Configuration

Types of Configuration

- You can:
 - Disable fields for input
 - Hide fields
 - Set predefined default values for fields
 - Set fields as mandatory
 - Add fields and frames
 - Control frame navigation



ADM_CONF_060

Each company that implements a particular function may use different features. This affects which fields are required and which are optional.

Configuration Examples:

- Generalized codes validation
- Optional modules
- Control settings

You must have a very clear understanding of how a particular function is being used before you change the data input requirements. You must thoroughly test the templates you create before using them in a production environment.

Users and Templates

Users and Templates

- Changes saved as customized UI template
- Templates are assigned to users based on
 - Groups in Standard Edition
 - Roles in Enterprise Edition
- Generic templates can be used by all users



ADM_CONF_070

Screen definitions are stored as UI templates, which can be assigned to user groups so that the screen appearance and behavior can vary based on the user's role within an organization.

In QAD Enterprise Applications Enterprise Edition, the user group function is replaced by the role function. To enable Configurable Screens in Enterprise Edition, you therefore enter the name of the role to which you want to assign the function in the UI Design Group setup field. The users to which this role has been assigned are then authorized to use Configurable Screens.

Error Handling and Template Conflicts

Error Handling and Template Conflicts

- Error messages displayed when mandatory fields hidden or removed
- Possible conflicts when users belong to more than one group
- Conflict management tool to list users, programs, and conflicts



ADM_CONF_080

When you hide a field that is validated by the system, and attempt to progress through the frame containing the field, the system displays the following error message:

```
The following error was caused by a configurable screen setting.
Please contact your System Administrator.
ERROR: Country code does not exist. Please re-enter.
```

Use the Configurable Screen UI Template Conflicts screen to resolve conflicting template assignments. If a user belongs to more than one group, the system uses the template associated with the first group assigned to the user. You can view and manage these conflicts using the UI Template Conflicts function, accessible from the Configurable Screens table on the Configurable Screens Admin screen. The administrator can use the drop-down list in the Conflict column to select the group assignment that the system should prioritize.

Configurable Screens Setup

Configurable Screens Setup

- Administration | Configurable Screens
- Choose Configurable Screens Setup
- Set Enable Configuration Screens
- Specify role (group) for UI Design Group
- Click Save



ADM_CONF_090

To set up configurable screens:

- 1 Choose Administration, Configurable Screens.
- 2 Select Configurable Screens Setup.

Enable Configurable Screens. Select this field to enable the function for members of the UI Design Group. If you do not select the field, the function is disabled for all users.

UI Design Group. Enter the name of a role that is authorized to create and modify screen templates. Only users assigned to this group can create configurable screen templates. In QAD EE, you can create a specific role for Configurable Screens using Role Create (36.3.6.1).

In QAD SE, enter the name of a group created in User Group Maintenance.

Click Save to apply this setting.

Configurable Screens Setup

- In User Option Telnet Maintenance, verify Program Execution is enabled for your user

The screenshot shows a web browser window titled "User Option Maintenance". The browser's address bar contains "User Option Maintenance" and the page has a menu bar with "Go To", "Actions", "Copy", "Print", and "Preview". Below the menu bar, there is a "User ID:" field. The main content area contains several configuration options:

Restrict Menu:	<input type="checkbox"/>	Max Web Connections:	<input type="text" value="2"/>
Menu Substitution:	<input checked="" type="checkbox"/>	Max Browse Records:	<input type="text" value="100"/>
Program Execution:	<input checked="" type="checkbox"/>	Session Timeout:	<input type="text" value="60"/>
Server Print:	<input checked="" type="checkbox"/>	Browse Timeout:	<input type="text" value="2"/>
Save Brw Settings:	<input type="checkbox"/>		

Below these options is an "Expiration Date:" field.

Creating Template

Creating Template

- Select the program to configure
- Right-click to select Design
- Enter a name, description, and roles for the template
- Click Configure to enter Design mode



ADM_CONF_110

Right-click the program name in the Applications area, and select Design to display the setup screen.

You can assign this template to all users, or select a specific role.

Templates are defined per program. When you select Design for a program, the existing templates for this program are listed, and you can use Delete to remove unwanted templates, or Copy to copy an existing template. When you copy a template, the copy is re-named by adding a 1 to the template name.

Creating Template

The screenshot displays the QAD Enterprise Applications interface. A 'Configurable Screens Setup' dialog box is open, showing a table with the following data:

Template	Description	All Users	Groups
SOM_SALES1	Custom SO Maint for Sales 1	<input checked="" type="checkbox"/>	

Buttons for 'Delete', 'Copy', 'Preview', and 'Configure' are visible on the right side of the dialog. The 'Configure' button is highlighted with an orange box. Below the dialog, there are fields for 'Pricing Date:', 'Purchase Order:', 'Remarks:', 'Credit Terms Interest %:', 'Reprice/Edit: ', and 'Entered By:'. 'Back' and 'Next' buttons are at the bottom right.

QAD

ADM_CONF_120

Template Considerations

Template Considerations

- Templates control the behavior of the program
- When creating a new record to navigate through a screen, the database is not updated, but the record sequential number may be incremented
- When using an existing record, you may hide a mandatory field, which will not produce an error until the template is saved and the program is run



ADM_CONF_130

Each template defines how fields display, whether they are required and enabled, if default values are supplied, and any automatic navigation from frame to frame.

To move through the sequence of frames in a program, you must either create a new record or modify an existing one. In cases where new records are assigned sequential numbers, it may be better not to create new records. Although the records are not saved, number sequences are incremented.

If you hide a required field and test with an existing record that has a field value, no error is generated. Later when a user attempts to create a new record, template errors may occur because a field that needs input cannot be updated.

Performance Considerations

Performance Considerations

- Consider the impact on the database of deleting the field at a later stage
- If the field is in constant use, many records are created for it
- When you delete, you delete the field and all its values
- You can remove the field from the frame without deleting it



ADM_CONF_140

When you create your own field and frame, you add the field to the schema, and as the program is used, users add values to it. When you delete, you delete the field and all its stored values from the database. Use the Disable or remove options to remove a field from the screen without deleting it from the database.

Configure Screen

Configure Screen

- Auto Navigate
- Available and Selected Fields
- Field Properties
- Tab Order

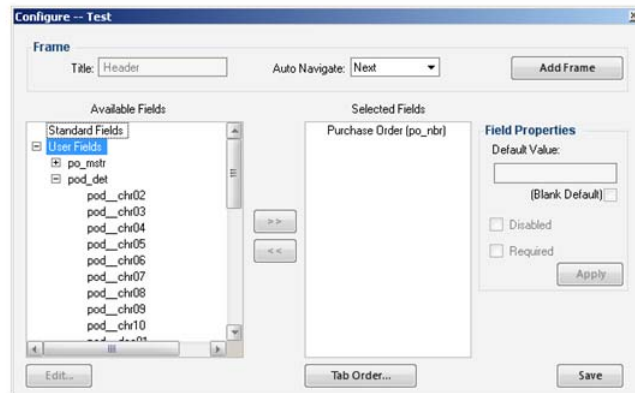

ADM_CONF_150

You can click the Save button at any time to save your changes and leave configuration mode. Your changes are also saved each time you click Next or Back to access a new frame.

Auto-Navigate. Use Auto-Navigate to control navigation between frames. You can use the Next and Back options to skip entire frames. To skip an entire frame without generating an error, the proper defaults must exist for all required fields. Next and Back have a similar effect; use them to skip the display of a frame. Which one you use depends on the normal screen navigation.

Available Fields. This area displays the user-defined fields you can add to the current frame or to a new frame. These fields are defined for each program in the `configscreens.xml` file.

Selected Fields. This area displays the fields selected for use on the current frame.

Tab Order. The tabbing order is the sequence in which you access fields using the Tab key. Click to display the tabbing order of fields in the current Frame. Use the Up and Down buttons to change the order, if required.

Available Fields

Available Fields

- Standard Fields and User Fields
- Tables and fields defined in `configscreens.xml`
- Add new user fields to `configscreens.xml`
- Default values for fields

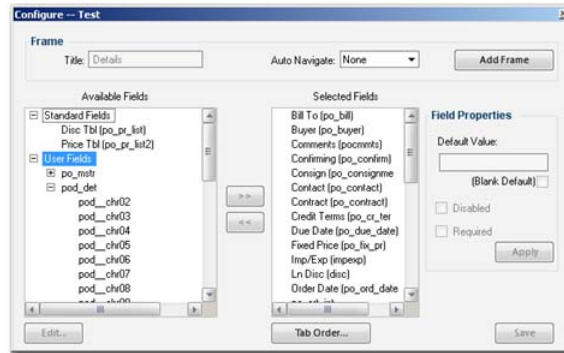

ADM_CONF_160

Standard Fields. These are existing data fields for the program. The Standard fields area only displays fields that have been hidden from the screen as part of a previous customization.

User Fields. These are the default user customization fields that are defined for all tables.

Adding New Fields and Tables to Programs

When you design a program, the user fields available to add to the screen are displayed in the Available Fields area. You can add these to existing frames, or create a new frame to contain one or more of these fields.

By default, only specific tables and fields are displayed for a particular program. These tables and fields are defined in the `configscreens.xml` file.

Default Values

You can add a default value to existing or new fields, which is displayed in red on the screen. A drop-down list of default values (None, True, or False) is displayed beside logical-type fields. Defaults you specify for a template override any other defaulting logic associated with a field and are only applied to new records; when a record is being edited, no field values are overridden.

Field Properties

Field Properties

- Editing Field Properties
- Field Validation
- Generalized Codes
- Program Validation



ADM_CONF_170

The Edit Field screen displays read-only properties for the selected field, and lets you modify the field label and validation.

Note The Edit Field screen is not available for Standard Fields.

Table. This read-only field displays the database table for which this field is defined.

Name. This read-only field displays the field name.

Data Type. This field displays the field type: character, date, logical, decimal, user 1, or user 2

Format. This read-only field displays the field data format, for example, the maximum number of characters for a character field.

Label. This field displays the field label. Note that the system will translate the value you put in the Label field if the value is a label term. Otherwise, the system will just use the value for the label.

Generalized Code Validation. Check this field to ensure that the values for this field are based on the values specified in Generalized Code Maintenance (36.2.13). You can use Generalized Codes Validation Rpt (36.2.15) to view a list of database fields that have schema validation assigned.

Note When adding values in Generalized Codes Maintenance, you must specify the full table and field name. For example, if specifying values for the field `pt_chr01`, you enter the table and field name `pt_mstr.pt.chr01`.

Program. Use this field to enter the name of a user-defined Progress program that validates the field.

You can use the program template `gpvalidate.p` to create your own Progress programs. This template is stored in the `QADInstallDir/qadui/com/qad/shell/interface` directory and contains instructions for usage. Copy the template and rename it appropriately.

Adding Lookups to Fields

Adding Lookups to Fields

- Use Drill-Down/Lookup Maintenance
- Enter the full table and field name

The screenshot shows a window titled "Drill Down/Lookup Maintenance" with a menu bar containing "Go To", "Actions", "Copy", "Print", and "Preview". The main content area displays the following configuration:

- Drill Down/Lookup: Lookup
- Field Name: admastr.adchr02
- Calling Procedure: adbr007.p
- Procedure To Execute:
- Description Term:
- Description:
- Lookup Starts At Row: 7
- Lines In Lookup: 6



ADM_CONF_180

Use Drill-Down/Lookup Maintenance (36.4.8.1) to assign drill-downs or lookups to fields that do not have a browse, to replace a browse, or to delete one.

Warning Most programs attached to a function with Drill-Down/Lookup Maintenance display values in a database table. You can attach any Progress function to a field, and this program executes when the user selects Help. For example, you can attach the program `calculat.p` to field `pt_avg_int` to display a calculator.

Using Added Fields in Character Code

Using Added Fields in Character Code

- Using the `gpngenfld.i` include file
- `gpngenfld.i` get and set function calls



ADM_CONF_190

You can modify character code to add new fields to program screens. New fields can be added to existing tables without requiring schema changes. These fields are not physically part of the master tables but are stored in a side table and thus require a different way to access their values from the code. For this purpose, the include file `gpngenfld.i` gives access to the values of these new fields through function calls.

Note This function is only used when modifying character code.

To gain access to the get and set function calls, include this file at the top of the program that will use them, for example:

```
{com/qad/mfgpro/gpngenfld.i}
```

Adding Frames

Adding Frames

- Custom frames and user-defined fields can be added to configurable screens

The screenshot shows the 'Sales Order Maintenance' window with a 'Custom Frame' dialog box open. The dialog box has three input fields: 'so_dte01' (a dropdown menu), 'so_chv08' (a text field), and 'so_chv07' (a text field). The background form displays various order details including Order: 10001, Sold-To: 01000000, Bill To: 01000000, Ship-To: 01000000, and a list of dates and pricing information.

The Frame button is only available when there are available fields to add. A default message (8622, See User Guide for adding User Fields) is displayed when no fields are available.

The new frame is displayed behind the Configure screen. To add fields to the screen, use the arrow key to move fields from the Available Fields area to the Selected Fields area. Use the cursor to position fields in the frame, and click the Tab Order button to set the tabbing order for the frame.

Click Save to save this frame and insert it into the program sequence, or Remove Frame to remove the frame from the sequence. When you remove a frame, the fields are selectable again in the Available Fields area.

When you create a new frame, save your updates and exit Configure Screens, the frame is displayed immediately following the current frame when you next launch the program.

Adding Frames

- Frames option only available when fields are available
- Use Tab Order to set the tabbing order

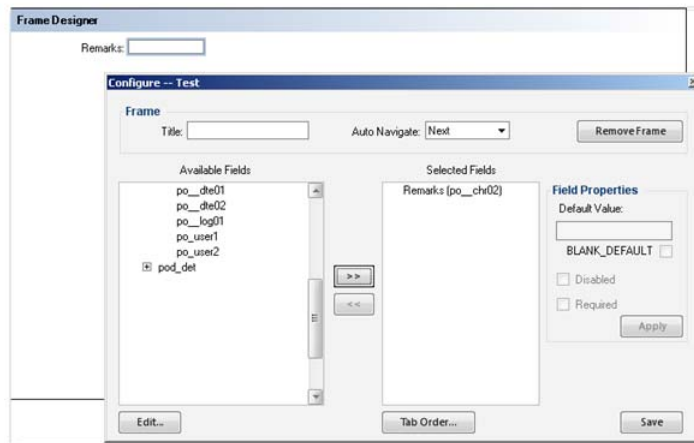

Template Conflicts

Template Conflicts

- Use the Configurable Screen UI Template Conflicts screen to resolve template conflicts
- Conflicts can occur because an option has 2 or more templates, and each template is assigned to different groups, and users belong to both groups
- When a user has two or more templates assigned for the same program, the system uses the template associated with the first role (group) assigned to the user
- This might not be the expected behavior

Template Conflicts

- The UI Templates Conflict screen lists all users that belong to more than one group with an assigned template
- The administrator has to fix this problem by dropping one of the templates

Template Conflicts

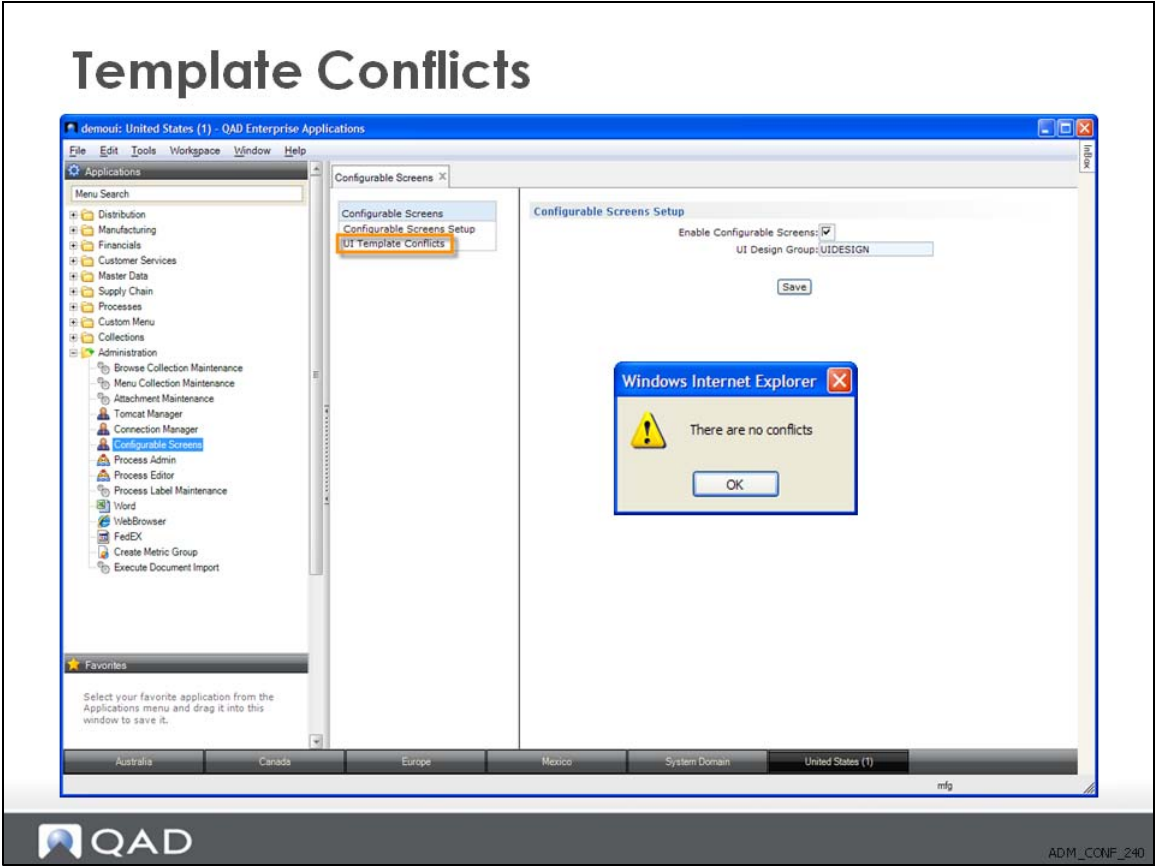

Configurable Screens Report

Configurable Screens Report

- Lists configured screens
- Includes details on individual fields

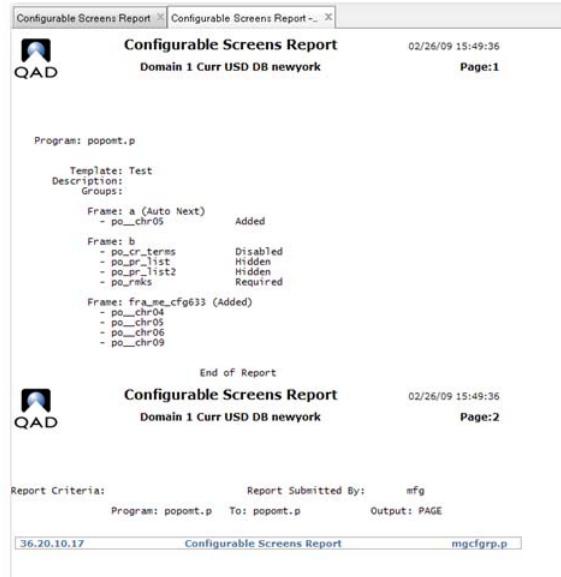

You can generate a report on individual configured screens or on all screens.

Exercise

Exercise

- Enable configurable screens
- Create a template for Item Master Maintenance
- Apply template to all users



Knowledge Check

- 1 How does Configurable Screens handle template conflicts?
- 2 You cannot delete design templates: True or False?
- 3 How do you define the tabbing sequence in a new frame?
- 4 In which file are new fields defined?
- 5 How do you add a lookup to a field?
- 6 What causes the Frame button to be unavailable?