



QAD Enterprise Applications  
Enterprise Edition

# User Guide

# QAD Manufacturing

Product Structures  
Routings and Work Centers  
Formulas and Processes  
Co-products and By-products  
Work Orders  
Shop Floor Control  
Advanced Repetitive  
Repetitive  
WIP Lot Trace  
Quality Management  
Forecasting/Master Schedule Planning  
Material Requirements Planning  
Capacity Requirements Planning  
Reports, Browsers, and Inquiries for .NET UI

70-3171A  
QAD Enterprise Applications 2011.1  
Enterprise Edition  
September 2011

This document contains proprietary information that is protected by copyright and other intellectual property laws. No part of this document may be reproduced, translated, or modified without the prior written consent of QAD Inc. The information contained in this document is subject to change without notice.

QAD Inc. provides this material as is and makes no warranty of any kind, expressed or implied, including, but not limited to, the implied warranties of merchantability and fitness for a particular purpose. QAD Inc. shall not be liable for errors contained herein or for incidental or consequential damages (including lost profits) in connection with the furnishing, performance, or use of this material whether based on warranty, contract, or other legal theory.

QAD and MFG/PRO are registered trademarks of QAD Inc. The QAD logo is a trademark of QAD Inc.

Designations used by other companies to distinguish their products are often claimed as trademarks. In this document, the product names appear in initial capital or all capital letters. Contact the appropriate companies for more information regarding trademarks and registration.

Copyright ©2011 by QAD Inc.

Manufacturing\_UG\_v2011\_1EE.pdf/mat/crl

**QAD Inc.**

100 Innovation Place  
Santa Barbara, California 93108  
Phone (805) 566-6000  
<http://www.qad.com>

# Contents

<b>What's New?</b> .....	<b>xiii</b>
<b>Chapter 1 Introduction to Manufacturing</b> .....	<b>1</b>
Lean Manufacturing Modules .....	3
Flow Scheduling .....	3
Kanban .....	3
<b>Chapter 2 Product Structures</b> .....	<b>5</b>
Introduction .....	6
BOM Codes .....	7
Alternate Structures/Formulas .....	8
Phantoms .....	8
Simulated BOM Inquiries .....	9
Setting Up a Product Structure .....	9
Related Topics .....	13
Floor Stock .....	13
Relationship with Configured Products .....	13
Component Substitutions .....	13
Cumulative Lead Time .....	14
Engineering Effectivity .....	15
<b>Chapter 3 Routings and Work Centers</b> .....	<b>17</b>
Introduction .....	18
Departments .....	19
Work Centers .....	20
Work Center Capacity .....	23
Standard Operations .....	23
Operation Capacity .....	24
Routings .....	25
Alternate Routings .....	26
Work Center Routing Standards .....	27
Routing Cost Roll-Up .....	27
Lead Times .....	27
Operation Lead Time .....	28

Manufacturing Lead Time .....	29
Subcontract Operations .....	29
Yield .....	29
Yield Percent .....	30
Operation-Based Yield .....	30
<b>Chapter 4 Formulas and Processes .....</b>	<b>33</b>
Introduction .....	34
Defining Formulas .....	34
Defining Processes .....	36
Process/Formula Maintenance .....	37
<b>Chapter 5 Co-products and By-products .....</b>	<b>39</b>
Introduction to Co-products and By-products .....	40
Concepts .....	40
Co-product/By-product Workflow .....	42
Setting Up a Co/By-product Operation .....	43
Setting Up Mix Variance Accounts .....	43
Setting Up Sites and Locations for the Base Process .....	44
Setting Up Work Centers .....	44
Setting Up Product Lines .....	44
Setting Up Item Status Codes for the Base Process .....	44
Setting Up the Base Process Item .....	44
Setting Up Items for Co-products and By-products .....	45
Setting Up a Co/By-product Structure .....	45
Setting Up Structures for Recyclable By-products .....	47
Setting Up Unit of Measure Conversion Factors .....	48
Setting Up Alternate Base Processes .....	49
Setting Up Alternate Base Process Routings .....	49
Setting Up Definitions for Valid Substitute Items .....	49
Calculating Costs and Lead Times .....	50
Allocating Costs to Co-products .....	50
Entering By-product Costs .....	51
Freezing By-product Costs .....	52
Rolling Up Costs .....	52
Calculating Average Costs for Co-products .....	52
Defining the Average Cost Allocation Methods .....	53
Average Cost Accounting .....	54
Rolling Up Lead Times .....	55
Reviewing Product Costs .....	55
MRP for Co-products/By-products .....	56
Planning for By-products .....	56

Planning for Co-products .....	56
Planning for Base Processes .....	57
Reviewing, Updating, and Reporting Action Messages .....	58
Approving Planned Work Orders .....	58
Creating Planned Order Reports .....	58
Creating MRP Summary Reports .....	58
Identifying the Source of Demand for a Co-product .....	58
Managing Joint Work Order Sets .....	59
Joint Work Order Sets .....	59
Accessing and Modifying Joint Order Sets .....	59
Creating a Joint Order Set from an Alternate Base Process .....	61
Reviewing, Printing, and Releasing Joint Orders .....	61
Receiving, Scrapping, and Backflushing .....	62
Receiving Unplanned Items .....	63
Processing Shop Floor Control Transactions .....	64
Processing Joint Orders at Work Order Close .....	64
Deleting and Archiving Joint Orders .....	64
Tracing Lots .....	64
Accounting for Joint Orders .....	64
Restrictions .....	70
Inventory .....	70
Purchasing .....	70
Repetitive and Advanced Repetitive .....	71
<b>Chapter 6 Work Orders.....</b>	<b>73</b>
Introduction .....	75
Work Order Life Cycle .....	75
Manufacturing Environments .....	76
Work Order by Site Control .....	76
Restricted Transactions .....	76
Effects of Optional Modules .....	77
Defining Control Settings .....	77
Creating Work Orders .....	78
Work Order Type .....	79
Work Order Status .....	82
Routing Code .....	85
BOM/Formula .....	85
Scheduling Work Orders .....	85
Manually Controlling Due Dates .....	86
Lead Time Calculations .....	87
Scheduling Operations .....	87
Modifying Work Orders .....	88
Modifying Work Order Bills .....	88

Modifying Work Order Routings . . . . .	89
Releasing Work Orders . . . . .	89
Key Items . . . . .	90
Splitting Work Orders . . . . .	90
Creating Picklists . . . . .	90
Reprinting Picklists . . . . .	91
Issuing Components . . . . .	91
Work Order Component Issue . . . . .	92
Issuing and Receiving Between Sites . . . . .	92
Subcontract Operations . . . . .	93
Receiving Work Orders . . . . .	94
Receiving and Backflushing . . . . .	95
Managing Scrap . . . . .	97
Generating Reports . . . . .	99
Closing Work Orders . . . . .	100
Work Order Accounting Close . . . . .	101
General Ledger Period End . . . . .	102
Deleting Work Orders . . . . .	102
<b>Chapter 7 Shop Floor Control . . . . .</b>	<b>103</b>
Introduction . . . . .	104
Reporting Labor by Operation . . . . .	104
Employee . . . . .	104
Department . . . . .	105
Work Center . . . . .	105
Item Quantities . . . . .	105
Times . . . . .	106
Operation Status . . . . .	106
Recording Nonproductive Labor . . . . .	107
Reporting Scrap . . . . .	107
Closing Operations . . . . .	108
Generating Reports . . . . .	109
Transactions . . . . .	109
Downtime . . . . .	111
Input and Output . . . . .	111
Utilization and Efficiency . . . . .	112
Deleting and Archiving Transactions . . . . .	112
<b>Chapter 8 Advanced Repetitive . . . . .</b>	<b>113</b>
Introduction . . . . .	114
Advanced Repetitive and Repetitive . . . . .	114
Distinctive Features of Advanced Repetitive . . . . .	114

Setting Up Advanced Repetitive . . . . .	116
Defining Control Program Settings . . . . .	116
Setting Up Production Lines . . . . .	119
Setting Up Line Allocations . . . . .	122
Setting Up Shifts . . . . .	122
Setting Up Changeover Times . . . . .	124
Setting Up Routings and Operations . . . . .	124
Setting Up Locations . . . . .	126
Simulating Schedules in the Workbench . . . . .	126
Determining Order Multiples . . . . .	127
Sequence Numbers and Due Dates . . . . .	128
Production Quantities . . . . .	128
Scheduling and Lead Times . . . . .	128
Deleting Sequence Records . . . . .	129
Reviewing Line Schedules . . . . .	129
Creating Repetitive Schedules . . . . .	129
Updating a Repetitive Schedule from a Line Schedule . . . . .	129
Schedule Maintenance . . . . .	130
Reviewing Repetitive Schedules . . . . .	130
Exploding Repetitive Schedules . . . . .	130
Using Repetitive Picklists . . . . .	131
Calculate the Picklist . . . . .	132
Print the Picklist . . . . .	133
Transfer the Inventory . . . . .	134
Managing Cumulative Orders . . . . .	135
Cumulative Order Create . . . . .	136
Cumulative Order Close . . . . .	136
Cumulative Order Maintenance . . . . .	138
Executing Repetitive Transactions . . . . .	138
Shipping Documents . . . . .	138
Common Transaction Data . . . . .	139
Warning Messages . . . . .	140
Rate Variances . . . . .	140
Method Change Variances . . . . .	141
Repetitive Transaction Programs . . . . .	141
Generating Repetitive Reports . . . . .	147
Managing Subcontracting . . . . .	148
Subcontracting Overview . . . . .	148
Setting Up Preliminary Subcontract Data . . . . .	149
Setting Up Advanced Repetitive for Subcontract Operations . . . . .	153
Processing Subcontract Shipments . . . . .	155
Viewing Subcontracted WIP Materials . . . . .	165
Deleting/Archiving Subcontract Purchase Orders . . . . .	166

Subcontract Shipping Limitations in API Mode .....	166
Working with Planning and Scheduling Workbenches .....	167
Production Line Item Create .....	168
Production Line Item Update .....	169
<b>Chapter 9 Repetitive .....</b>	<b>171</b>
Introduction .....	172
Setting Up Repetitive .....	172
Defining Control Program Settings .....	172
Simulating Schedules in the Workbench .....	174
Creating and Exploding Repetitive Schedules .....	174
Using Repetitive Picklists .....	174
Managing Cumulative Orders .....	174
Executing Repetitive Transactions .....	174
Operation Reporting .....	175
Repetitive Completions .....	175
Reporting Completions .....	175
Repetitive Scrap Transaction .....	177
Checking Component Availability .....	177
Release Production Orders by Production Line .....	178
Manage Materials for Production Line .....	180
Release Production Orders by Work Center .....	180
Manage Materials for Work Center .....	181
Monitor Material Shortages .....	181
Purchase Direct Materials .....	183
Decimal Places .....	183
System Security .....	183
Component Check Calculations .....	184
Demand Supply Browse .....	185
Demand/Supply Summary Browse .....	185
Viewing Receipt Data .....	186
<b>Chapter 10 WIP Lot Trace .....</b>	<b>189</b>
Overview of WIP Lot Trace .....	190
WIP Lot Trace and Regulatory Attributes .....	190
Features .....	191
Subcontract Processing Features .....	191
Changes to Other Modules .....	191
WIP Lot Trace Programs .....	195
Planning for WIP Lot Trace .....	195
Deciding Which Material to Trace .....	196
Milestone and Non-Milestone Operations .....	196

Before Tracing Subcontracted WIP Material .....	196
Lot Sizing Restrictions .....	197
Inventory Lot Quantity Issuing Restrictions .....	197
Inventory References .....	197
Lot Splitting and Combining .....	197
Custom Lot/Serial Number Formats .....	198
Maintaining Accurate System Configuration Information .....	198
Setting Up WIP Lot Trace .....	199
Defining Control Program Settings .....	200
Registering Routing Exceptions .....	202
Registering BOM Exceptions .....	204
Working with WIP Lot Trace .....	205
Using WLT Data Collection Frames .....	206
Using WLT with Work Orders .....	213
Using WLT with Advanced Repetitive .....	219
Using WLT with Purchasing .....	220
Using WLT with Repetitive .....	223
Reporting WIP Lot Trace Data .....	224
<b>Chapter 11 Quality Management .....</b>	<b>227</b>
Introduction .....	228
Setting Up Quality Management .....	228
Setting Up Control Programs .....	229
Defining Specifications .....	229
Setting Up Procedures .....	231
Defining Sampling Patterns .....	232
Executing Stand-Alone Tests .....	233
Creating Quality Orders .....	234
Entering Quality Order Results .....	235
Deleting Quality Orders .....	235
Conducting Process Inspections .....	235
Conducting Other Tests .....	237
Inventory Audits .....	237
First Article Inspection .....	237
Process Validation .....	237
Destructive Testing .....	238
Printing Test Results .....	238
<b>Chapter 12 Forecasting/Master Schedule Planning .....</b>	<b>239</b>
Creating Forecasts .....	240
Forecast Creation Workflow .....	240
Forecasting Simulation .....	240

Setting Up Forecasting Simulation . . . . .	241
Creating Criteria Templates . . . . .	241
Calculating Forecasts . . . . .	246
Manually Creating Forecasts . . . . .	247
Modifying Forecast Results . . . . .	247
Copying and Combining Forecasts . . . . .	248
Generating Reports . . . . .	251
Making Forecast Data Visible to MRP . . . . .	252
Deleting and Archiving Forecasting Detail Records . . . . .	253
Maintaining Forecasts Outside of Forecast Simulation . . . . .	254
Consuming Forecasts . . . . .	255
Sales Order Demand . . . . .	255
Net Forecast Calculation . . . . .	255
Forward and Backward Forecast Consumption . . . . .	255
Creating Master Production Schedules . . . . .	257
Master Scheduled Items . . . . .	257
Approaches to Master Scheduling . . . . .	257
Available-to-Promise . . . . .	259
Multilevel Master Scheduling . . . . .	259
Maintaining Master Schedule Orders . . . . .	262
Verifying Capacity for Master Schedules . . . . .	263
Master Scheduling for Seasonality . . . . .	263
Generating Master Schedule Reports . . . . .	264

**Chapter 13 Material Requirements Planning . . . . .267**

Introduction . . . . .	268
MRP and Sites . . . . .	268
Sources of Demand and Supply . . . . .	268
Setting Up MRP . . . . .	269
MRP Control . . . . .	269
Item Planning Data . . . . .	271
Inventory Status Codes . . . . .	275
Product Structures and Formulas . . . . .	276
Executing MRP . . . . .	276
MRP Processing . . . . .	276
MRP Scheduling . . . . .	278
MRP Pegged Requirements . . . . .	278
MRP Planning Modes . . . . .	279
Reviewing MRP Output . . . . .	280
Action Messages . . . . .	281
Planned Orders . . . . .	282
Approving Planned Orders . . . . .	283
Approving Planned Purchase Orders . . . . .	283

Approving Planned Work Orders .....	283
Approving Planned Line Orders .....	283
<b>Chapter 14 Capacity Requirements Planning .....</b>	<b>285</b>
Introduction to CRP .....	286
Defining Capacities .....	286
Executing CRP .....	286
Back Scheduling .....	287
Generating Load Reports .....	288
Reviewing Input and Output .....	288
Adjusting Capacity and Load .....	289
Adjusting Capacity .....	289
Adjusting Load .....	289
<b>Chapter 15 Reports, Browsers, and Inquiries for .NET UI .....</b>	<b>291</b>
Introduction .....	292
Using Enhanced Reports .....	292
Running a Report .....	293
Running Reports Directly From Browsers .....	294
List of Modified Reports, Browsers, and Inquiries .....	294
<b>Index .....</b>	<b>295</b>



# What's New?

The following table summarizes significant differences between this document and the version released with QAD 2011 Enterprise Edition.

<b>Date/Version</b>	<b>Description</b>	<b>Reference</b>
September 2011/2011.1 EE	Rebranded for QAD 2011.1 EE	--



# Introduction to Manufacturing

Manufacturing modules handle internal supply and demand—material is moved out of inventory into production, or finished goods or components are moved from production into inventory. These modules are used by make-to-stock, assemble-to-order, process, batch process, flow, kanban, and repetitive operations.

Figure 1.1 illustrates the manufacturing modules.

**Fig. 1.1**  
Manufacturing

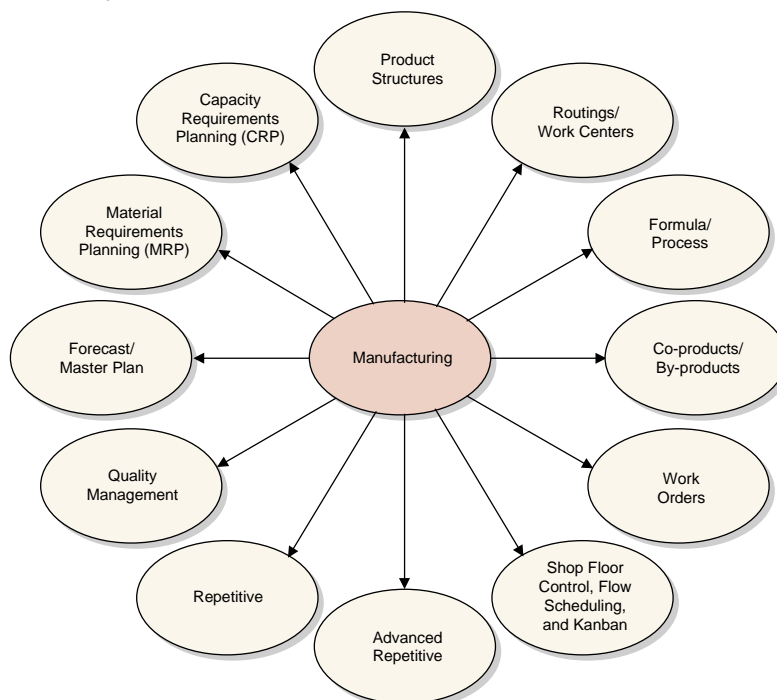

**Product Structures 5**

Once items such as products, components, and materials are identified in your system, the Product Structures module adds and maintains the bills of material for each product, assembly, subassembly, intermediate, and fabricated part.

**Routings and Work Centers 17**

The Routings/Work Centers module defines the areas where manufacturing activities are performed (departments, work centers) and the manufacturing process itself (operations and routings).

**Formulas and Processes 33**

The Formula/Process module defines and maintains the relationships between products and the ingredients that go into them, as well as the process by which they are created. Other Formula/Process functionality is discussed in conjunction with co-products and by-products. Co-products/By-products is used to manage processes that create more than one product.

**Co-products and By-products 39**

Co-product/By-product features manage processes that create more than one product. The module includes tools for setting up items, structures, and routings and supports MRP, work orders, shop floor control, and costing.

**Work Orders 73**

The Work Orders module is used in discrete production environments to control manufacturing orders. Create work orders manually or generate them from MRP planned orders. Generate work orders for configured products directly from a sales order. The Work Orders module supports co-product and by-product manufacturing.

**Shop Floor Control 103**

The Shop Floor Control module tracks activities and records operation status and labor times for manufacturing jobs released through the Work Orders module.

**Advanced Repetitive 113**

The Advanced Repetitive module supports high-volume manufacturing where lead times are more than a day and up to a month or more; where work is continuous and lines are dedicated to one item for days, weeks, or months; and where work in process (WIP) costs are either variable or high enough to track closely.

**Repetitive 171**

The Repetitive module supports high-volume manufacturing where lead times are one day or less, where WIP is complete at the end of each day, where WIP costs are tracked and batches do not overlap, or where WIP costs are insignificant or fairly constant.

**Quality Management 227**

The Quality Management module defines standard testing procedures, applies tests to work orders and repetitive schedules, records quality test results, and manages inventory sampling and quality work orders.

**Forecasting/Master Schedule Planning 239**

The Forecast/Master Schedule Planning module lets you create and maintain shipment forecasts and master production schedules. Using this module, you can analyze sales shipment history, calculate forecasts, and update demand for material requirements planning (MRP), creating a closed-loop system.

**Material Requirements Planning 267**

Material Requirements Planning (MRP) is a key manufacturing planning function. It assesses supply and demand and generates planned order and action messages. For organizations with multiple sites, MRP can be used in conjunction with distributed requirements planning (DRP), which balances supply and demand among sites.

**Capacity Requirements Planning 285**

The Capacity Requirements Planning (CRP) module uses MRP planned orders, other work orders, and repetitive schedules to determine work-center load and generate a capacity requirements plan for a department, work center, or machine.

## Lean Manufacturing Modules

In addition, lean manufacturing functionality is provided by the Flow Scheduling and Kanban modules.

### Flow Scheduling

The Flow Scheduling module lets you create and manage the life cycle of time-phased production schedules for use in a flow-driven, lean manufacturing environment. Optionally, you can link flow scheduled orders with existing demand orders and work orders.

See *User Guide: QAD Lean Manufacturing*.

### Kanban

The Kanban module lets you identify items that are kanban controlled, maintain kanban-related data for these items, print kanban cards on demand, and use kanban transactions to track and manage the movement of kanban-controlled items in and out of the production process.

See *User Guide: QAD Lean Manufacturing*.



# Product Structures

This chapter discusses how product structures—also known as bills of material—are defined and used during MRP and other planning activities to determine what materials are required for manufacturing.

***Introduction*** 6

Outlines the use of product structures and formulas as interdependent variables that describe the relationship between products and components.

***BOM Codes*** 7

Outlines the Bill of Materials (BOM) codes and the programs used to set them up.

***Alternate Structures/Formulas*** 8

Describes alternative methods for using BOM codes and product structures depending on how an item will be used.

***Phantoms*** 8

Defines phantoms and explains how to identify them, how to use them effectively, and changes that may be required to use them.

***Setting Up a Product Structure*** 9

Describes how to define Product Structures and describes important fields in Product Structure Maintenance (13.5).

***Related Topics*** 13

Describes some topics that are related to product structures and how they are used.

## Introduction

Product structures and formulas are much like the list of ingredients for a recipe—they indicate the components and quantities needed to make a product. Unlike a recipe, in many cases, these documents also list the ingredients for each component. Graphically, if a formula or product structure is considered in its entirety, it looks like a tree, with the parent item at the top (level 0) and all the components branching off down to the raw material level (levels 1, 2, 3, and so on).

See Chapter 4, “Formulas and Processes,” on page 33.

Product structures are recorded as single-level relationships between parent (or higher-level items) and component items. For formulas, these are the relationships between products and ingredients.

Product structures are modular. Separate structures are entered for finished goods and lower-level assemblies or intermediate products. So, a component in a higher-level structure might be a parent in a lower-level structure. Looking in the other direction, a parent in a lower-level structure can be a component in a higher-level structure. The system can display product structures as either indented, multilevel bills of material or as single-level bills.

This chapter uses an example of a manufactured product with both a product structure and a formula: sports sunglasses with specially coated lenses.

Viewed from the top, three components make up the parent product: a frame assembly, a left lens, and a right lens. Each component has its own structure. The frame assembly includes a lens frame, left and right sides, and so on. Table 2.1 illustrates this two-level product structure.

**Table 2.1**  
Product Structure for Sunglasses with Coated Lenses

<b>Frame Assembly</b>	<b>Left Lens</b>	<b>Right Lens</b>
Lens frame	Lens blank	Lens blank
Left temple	Tint	Tint
Left hinge kit	Coating	Coating
Right temple		
Right hinge kit		
Screws (2)		
Adhesive		

If a single company manufactures the whole product, each structure has its own specific manufacturing steps:

- Assemble frames.
- Grind lenses to size, polish, tint, and coat.
- Assemble sunglasses from frames and lenses.

Or the company might buy the frames, only doing lens grinding, coating, and final assembly. Because it might be necessary to ensure a supply of spare screws, the frame can have its own product structure so the product structure reports show which frames require these screws.

You can enter product structures for purchased products without affecting planning or product costing programs. This way, you can use all the product structure reporting tools for component and parent items, regardless of the source of the items.

The system also uses product structure records to store alternate bills of material, planning bills, and configuration bills. Separate these from standard bills by using a structure code.

See “BOM Codes” on page 7.

Figure 2.1 shows data records associated with product structures and formulas that are discussed in this chapter. Not every system uses all of these.

**Fig. 2.1**  
Product Structure/Formula Flow

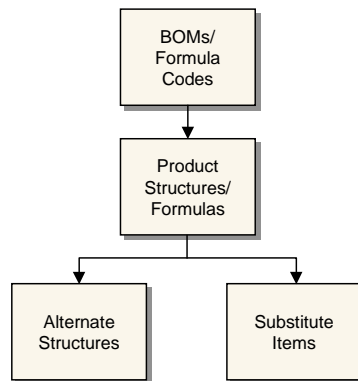

## BOM Codes

Sometimes, a single product structure or formula can produce more than one kind of product.

**Example** A company uses the same formula for a beverage or a cheese, but depending on how it is processed and aged, different products result. In this case, it does not make sense to define the formula with respect to one specific product.

In another case, one product can be produced with several different product structures or formulas.

**Example** A computer workstation is assembled in different countries around the world. Several different product structures use slightly different components produced by different manufacturers. No matter which product structure is used, the end product is functionally equivalent. Depending on where the product is manufactured, one structure may be more favorable as a result of cost differences due to price and/or tax considerations.

In both cases, enter product structures and formulas by using a product structure/formula—or bill of material (BOM)—code as the parent item instead of an item number. Use two programs to set up BOM codes:

- Product Structure Code Maintenance (13.1)
- Formula Code Maintenance (15.1)

**Note** The system automatically creates BOM codes for parent items that are defined in the item master when adding product structures and formulas.

BOM codes and item numbers are entirely independent. You can use the same product structure or formula for multiple items, and any one of several product structures or formulas to make the same item.

When an item number and its BOM code are the same, they are automatically linked. If an item's BOM code is blank, the item number is used as the BOM code. When they are different, you can change the BOM code in Item Planning Maintenance (1.4.7) or Item-Site Planning Maintenance (1.4.17).

## Alternate Structures/Formulas

An item can use a product structure that is defined for a BOM code different from the item number. After you have defined a BOM code and a product structure or formula, link it to an item based on how it will be used.

- If the structure/formula should be the default for an item, update the BOM code in Item Master Maintenance (1.4.1) or Item Planning Maintenance (1.4.7). The system uses this BOM code for MRP, work orders, repetitive manufacturing, and costing.
- If the structure/formula should be the default for an item at a particular site, update the BOM code in Item-Site Planning Maintenance (1.4.17). The system uses this BOM code for MRP, work orders, repetitive manufacturing, and costing for an item at a site. This overrides the BOM code set up at the item level.
- If the structure/formula should be available as an alternate for an item at any site, use Alternate Structure Maintenance (13.15) to link the BOM code with an item. You can then change the BOM code on a work order to this alternate structure/formula.
- If the structure/formula should be available as an alternate for an item at a specific site when a specific routing is used, use Alternate Routing Maintenance (14.15.1) to link a BOM code and routing code to an item-site. You can then change the BOM code on a work order to this alternate structure/formula when using the specified routing code.

## Phantoms

Sometimes engineering drawings and bills define transient product items that exist independently for a relatively short time and are not stocked. Instead, they are immediately consumed by higher-level products. These are called *phantom structures*.

**Example** Frames for sunglasses are assembled or purchased, but before final assembly, the company name is printed on the side. An engineering drawing specifies the exact location. The product structure now has one more level—a labeled frame. In practice, when the sunglasses are being manufactured, the labeling and final assembly processes may be so close together that the labeled frames (without lenses) exist only briefly.

A product that starts out as a normal subassembly that is kitted, manufactured, and stocked can later evolve into a phantom. If manufacturing engineering can support changes to the manufacturing flow, you can use phantoms to reduce inventory movement, shorten lead times, and effectively reduce the levels in a bill of material.

Using phantoms may require changes in manufacturing technology, or something as simple as introducing kanban to control the movement of components and phantoms.

Use Item Planning Maintenance (1.4.7) to identify an item as a phantom for all sites. When an item is a phantom at one site but not at another, indicate exceptions in Item-Site Planning Maintenance (1.4.17). Items that are marked as phantoms using either of these two programs are known as *global phantoms*.

If an item is a phantom only when assembled as a component of a specific parent item, use a structure type of X within the product structure or formula. Such a phantom is known as a *local phantom*, since its use as a phantom depends on a particular bill of material.

When Material Requirements Planning (MRP) plans requirements, it always ignores a local phantom and creates planned orders for its components. This process of driving requirements from the components is sometimes referred to as *blowing through* a phantom.

If there is a quantity on hand of a global phantom, MRP uses it to fill requirements before creating additional requirements for the components.

## Simulated BOM Inquiries

Quantities-on-hand of local phantoms do not impact the Simulated Picklist Item Check (13.8.17) or the Simulated Batch Ingredient Check (15.7.17). Use-up logic is typically not applied to local phantoms. This is one reason to define them as local, rather than global. Quantities-on-hand of global phantoms still decrement quantity requirements when you select use-up logic by setting the Use up PH field to Yes on these two inquiries.

Reports are also available for viewing simulated batch information:

- Simulated Batch Ingredient Report (15.7.18) is a standard report available in any user interface.
- Simulated Batch Ingredient Rpt (15.7.42) is an enhanced version of that report only available in QAD .NET UI.

## Setting Up a Product Structure

Define product structures in Product Structure Maintenance (13.5).

**Note** This section describes navigation in the QAD .NET UI.

You can define a product structure based on:

- An item number. Click the Items tab to select from the list.
- A BOM code. Select the Product Structure tab to select from the list.

Use standard .NET filtering tools to search the selected list as needed.

**Fig. 2.2**  
Product Structure Maintenance (13.5)

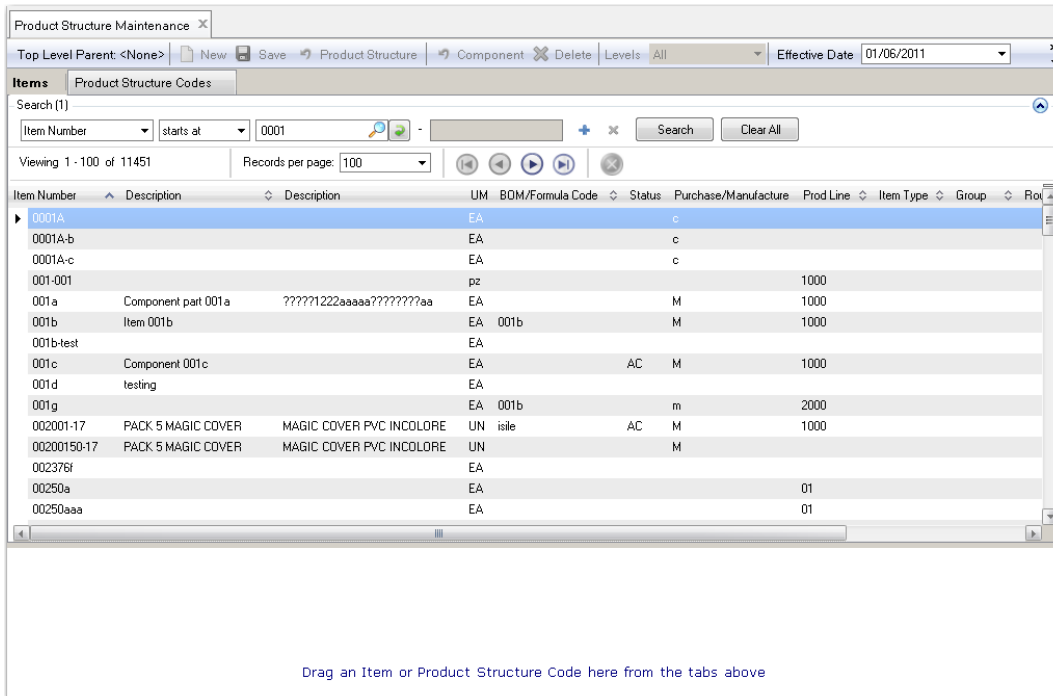

To create or maintain a product structure, drag and drop the item or BOM code into the bottom frame. If a structure already exists, the system displays it in a tree structure. You can modify it as needed.

To add a component item to the structure, drag and drop it onto the parent item.

To delete a component item (and any lower level components), right-click the item. Choose Undo Add if you have not yet saved the latest changes; otherwise, choose Delete.

Double-click a component item in the tree structure to view and update the record.

**Fig. 2.3**  
Product Structure Maintenance, Fields

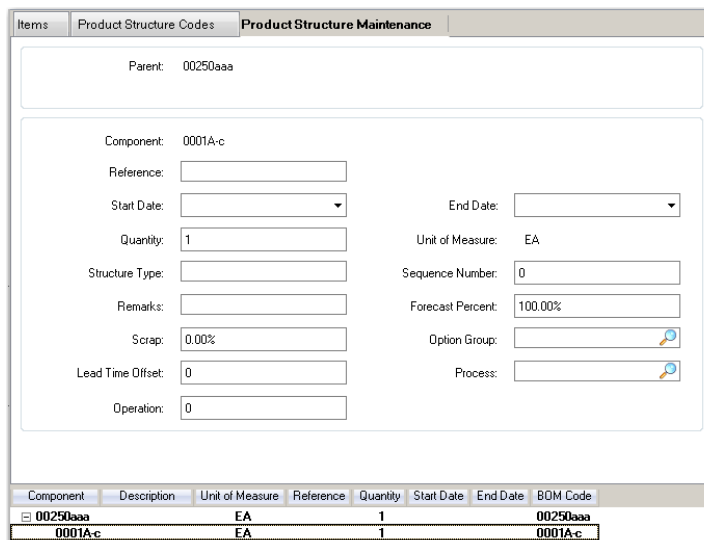

Important fields include the following:

**Reference.** On a complex assembly that contains many components, an item may appear several times on the same drawing and product structure. Use Reference to identify a component that appears multiple times on the same parts list.

The reference code can be a drawing reference number that helps to relate a component to a specific position on a drawing, or a code associated with an engineering change order or an engineering change notice. The system uses parent, component, reference, and start date to define a unique product structure record. A component can have the same parent and same reference as long as the start dates are different.

**Note** If you use the Product Change Control (PCC) module, engineering change notice functions in Product Structures are disabled. See *User Guide: QAD Master Data* for more information on PCC.

Since the system uses product structures to store configuration bills, you can also enter the feature code for configured products in Reference.

See “Engineering Effectivity” on page 15.

**Start and End Effective.** The way an item is manufactured can change over time. New components can be added or unnecessary ones deleted. Use effective dates to store relationships for historical, current, and future product structures.

All parent-component relationships are identified by a start and an end effective date. The start and end effective dates indicate when a relationship is active. A relationship is effective through the end date and becomes obsolete the next day.

**Example** The hinges and fasteners for a frame are being upgraded. The existing components have an end effective date of March 14, and the new components have a start date of March 15. If an adhesive is added to prevent the screws from coming loose, you can also record the new product structure with the start date of March 15.

**Quantity Per.** Specify how much of this component is needed to make the parent item. In discrete manufacturing, items are made in individual units, and the component quantity is the amount needed for a single unit of a parent product. For example, two screws are required for one pair of sunglass frames.

In process manufacturing, products are made in batches and the component quantity per parent on a formula or recipe is stated with respect to a batch quantity for the parent product. Since the only economical way to coat lenses is in batches, the amount of a particular coating might be specified for a batch of several hundred lenses.

**Scrap.** Depending on the product, some components may be lost or unusable as a result of the manufacturing process. There are two ways to anticipate this loss:

- Use the scrap factor.
- Change the component quantity per.

The scrap factor is the percentage of a component expected to be lost during manufacturing. The system uses this with the quantity per to calculate component requirements for work orders and MRP. When a scrap factor is used, component quantities are almost always extended into fractional amounts and not whole units, making it difficult to use with items always handled in discrete quantities.

**Example** One left lens is required for a pair of sunglasses and the scrap factor is 5%. The system calculates a requirement for 105.2631 left lenses to make 100 sunglasses.

Using scrap percentages other than zero promotes waste and can conceal quality problems. If additional quantities are consistently required, consider changing the component quantity per directly. This avoids the problem of fractional quantities but may result in even greater waste than using the scrap factor. Continuing the example of the sunglasses, it is not realistic to change the quantity per on the left lens to 2. If you did so, the system would always plan that 200 left lenses would be necessary to make 100 pairs of sunglasses.

*Structure Type.* Product structure relationships normally have a blank structure type code. Other codes are used for special applications.

**Table 2.2**  
Structure Type Codes

Code	Description
Blank	A normal product structure relationship.
X	A local phantom. Costed and exploded, but never planned as component requirements.
D	Document. Records miscellaneous expense items or documents associated with this bill that are not planned, exploded, or costed.
O	Option. An optional component. Normally defined using Configured Structure Maintenance (8.1), options may also be entered in planning bills.
P	Plan. Planning bill used for multilevel master scheduling. Not exploded or costed.
A	Alternate. Automatically created by the system for an alternate structure for this parent. Not planned, exploded, or costed.

Option and planning bills are used to create production forecasts.

See “Forecasting/Master Schedule Planning” on page 239.

*LT Offset.* Not all of the components of a manufactured item are always required at the beginning. Normally, the differences in timing are not significant. However, if components are required long after the start date and/or the cost of those components is significant, consider using lead time offset.

Enter a positive or negative number, indicating the number of days after or before the start of an order when this component is required. MRP uses lead time offset to determine the need date for components and segregate them on separate picklists for individual work orders.

*Op.* Enter the number identifying the operation in the routing or process where this component is used. When specified, operation has the following effects:

- Determines whether this component is backflushed in repetitive manufacturing operations. If you enter the operation number here, this component is automatically issued when you report quantities for the parent. If Op is blank or does not match a defined operation, this component is not backflushed. See “Backflush Transaction” on page 142.
- Enables component yield cost calculations. Product Structure Cost Roll-Up (13.12.13) and Routing Cost Roll-Up (14.13.13) use this field when calculating material costs. If the operation yield is less than 100% in Routing Maintenance (14.13.1), then material costs are increased to reflect yield loss. If blank, the system assumes components are issued at the first operation. See *User Guide: QAD Costing*.

- Enables operation-based yield calculations. If the parent item is defined with Operation Based Yield set to Yes in Item Master Maintenance and Enable Op Based Yield is Yes in MRP Control (23.24), MRP derives component yield percentages from the operations on the parent's routing. The same method is used when bills of material are exploded in work orders, repetitive, advanced repetitive, and configured products. See "Operation Based Yield" on page 30.
- Determines whether this component prints on Repetitive Picklist Print (18.22.3.5). If you enter an operation code, the component can be picked.

## Related Topics

This section discusses a number of topics related to product structures and how they are used in the system.

### Floor Stock

Continuing the example of the sunglasses, most items such as frame pieces and lenses are issued from an inventory location based on a formal document such as a work order picklist. However, some inexpensive, easily replenished components, such as the screws, may be held on the factory floor and used as needed. Such items are called *floor stock*.

Use Issues–Unplanned (3.7) to record floor stock issued from stores to a work-in-process expense account. To prevent these items from being picked, they should have an issue policy of No in the item master and item-site planning data.

Do not confuse floor stock with expensed items. Expensed items do not appear in the item master or product structure and are expensed immediately when they are received from the supplier. Enter expensed items on a purchase order as non-inventory (memo) purchases with type code M.

### Relationship with Configured Products

Product structure records are also used to store information on product configurations. A configured product is defined in Item Master Maintenance with a purchase/manufacture code of C (configured). The system uses the Reference field to store the option's feature group, and the Structure Code field defaults to Option.

See *User Guide: QAD Sales* for information on configured products.

In some instances, it may be appropriate to change the structure code to Planning.

See page 239.

### Component Substitutions

When an item is not available, you can sometimes issue a different item. For example, for the sunglasses, it may be possible to substitute Phillips-head screws for slotted-head screws. Substitute components during work order issues or when modifying a backflush transaction. Before substituting components, use Item Substitution Maintenance (13.19) to define the relationships between standard items and substitute items.

You can define a substitute item relationship for a component within a specific assembly as a global relationship. Specify a quantity of the alternate item that is equivalent to a single unit of the reference item. For example:

- Deionized water and sterile water can be defined as alternates for equivalent quantities of distilled water.
- Two 6-pin connectors can be defined as an alternate for a single 12-pin connector.
- A fast-setting adhesive can be defined as a substitute for a slower-setting adhesive for a specific assembly.

MRP and work order picking logic do not check substitute item relationships. Substitute items that are phantoms are not exploded when issued on an inventory transaction.

**Fig. 2.4**  
Item Substitution Maintenance (13.19)

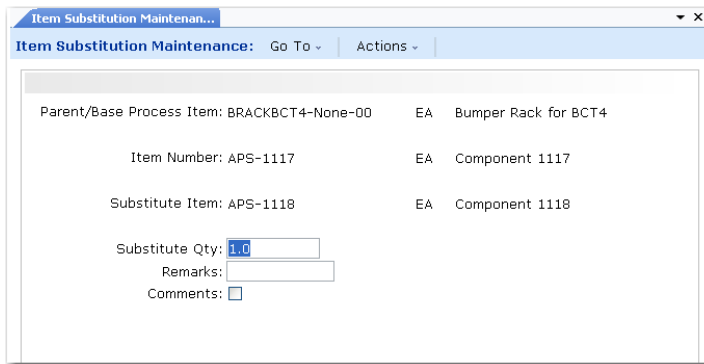

## Cumulative Lead Time

When a product is planned, it is sometimes necessary to know its cumulative lead time—the longest time required to produce it. The cumulative lead time determines the minimum planning horizon for the master schedule and material requirements planning.

Cumulative lead time is calculated by first determining the composite lead times between the product and each of the lowest level components. The longest of these composite lead times determines the critical path and sets the cumulative lead time. When a product structure contains a BOM code in a lower level, the cumulative lead time of the end item includes lead times for components of the BOM code.

**Example** Sunglasses are manufactured from a purchased frame assembly. Table 2.3 shows the lead time for each item.

**Table 2.3**  
Manufacturing Lead Times

Sunglasses with Coated Lenses (1)					
Frame assembly	(28)	Left lens	(2)	Right lens	(2)
		Blank	(7)	Blank	(7)
		Tint	(28)	Tint	(28)
		Coating	(35)	Coating	(35)

The composite lead times for the sunglasses are calculated for each of the component lead time paths starting from the top-level assembly and going down to the component, as illustrated in Table 2.4.

**Table 2.4**  
Composite Lead Times

Assembly or Component	Lead Time
Sunglasses with coated lenses	1
Frame assembly	29 (1 + 28)
Left or right lenses	3 (1 + 2)
Lens blank	10 (1 + 2 + 7)
Tint	31 (1 + 2 + 28)
Coating	38 (1 + 2 + 35)

The cumulative lead time, the longest of these lead time paths, is the lead time for coating (38 days). It could take up to 38 days to produce sunglasses if the critical components (left or right lenses and coating) are not available.

Use Cumulative Lead Time Roll-Up (13.12.14) to calculate and store the cumulative lead time in the item planning data for either the item master or the item-site.

## Engineering Effectivity

In some instances, you can use an engineering change order or engineering change notice so that existing inventory of an old component is consumed before a new component can be used.

**Note** If you are using Product Change Control, you can use the Incorporation Planning Report (1.9.7.3) to determine the best time to introduce an engineering change.

**Example** A particular coating material is to be replaced by new coating material after the old material runs out.

- Set up the new material up as a component of the existing coating material.
- Change the existing coating material to a phantom item in Item Planning Maintenance (1.4.7) and/or Item-Site Planning Maintenance (1.4.17).

Work order picklists use phantom use-up logic to pick available inventory of the existing coating material until it runs out. Afterward, the system explodes the product structure/formula to pick the new coating material.

There are three trade-offs to doing this:

- Product costs and cumulative lead times are not calculated correctly.
- Phantom use-up logic is not used when backflushing components in the Repetitive module. However, it is used when backflushing work orders and in Receipts-Backward Exploded (3.12).
- The product structure will not conform to the engineering structure, so the where-used and product structure programs will be less accurate.

Avoid these potential problems by managing the use of effective dates for engineering changes.



# Routings and Work Centers

This chapter discusses the elements associated with routings, including departments, standard operations, and work centers. Many of these concepts are also common to process definitions.

***Introduction*** 18

Outlines routing operations, their uses, and when they are or are not necessary.

***Departments*** 19

Defines departments, department codes, account numbers, and their uses.

***Work Centers*** 20

Defines work centers and explains how they are used by the system.

***Standard Operations*** 23

Describes how to create standard operations with Standard Operation Maintenance in order to save time and work.

***Routings*** 25

Defines routings, discusses their relationship to operations, and introduces Standard Routing Maintenance.

***Lead Times*** 27

Describes components that are used to describe manufacturing and operation lead times.

***Subcontract Operations*** 29

Describes how to set up work centers and departments to incorporate outside subcontractors.

***Yield*** 29

Describes how the system calculates total yield for an item using Yield Percentage and Operations-Based Yield.

## Introduction

To manufacture an item or product, you must complete one or more activities or operations. The list of required operations is called a routing, which basically defines the process needed to make the item. If a product structure is the list of ingredients in a recipe, a routing is the directions. The routing operations indicate the machines, expected times, and instructions for completing specific tasks.

For example, in manufacturing sunglass lenses, there might be a routing with four operations with instructions to grind, polish, tint, and coat the lenses. These would be separate operations because they involve different machines, tools, skills, and tasks.

In the Shop Floor Control and Repetitive modules, you record actual statistics on what happens during production. This might include how long it takes to produce items, what quantities are produced and by whom, whether there was downtime or some other interruption to production, and so on. These statistics are always recorded against a routing operation. Routings are required if you use the Repetitive module.

In addition to providing manufacturing instructions, routings contain data used as a standard for evaluating production, operation times, yield percentages, the number of machines normally needed, and so on. The department and work center codes associated with routing operations link actual production results with capacity planning, cost accounting, and other programs.

Specifically, routings can be used to:

- Calculate the cost of producing an item.
- Calculate the time it takes to manufacture an item.
- Schedule operations for work orders and repetitive schedules.
- Backflush components in the Repetitive module.
- Calculate work center and department load.
- Print routings for work orders.
- Obtain operation feedback using programs in Shop Floor Control, Repetitive, and Advanced Repetitive.

Some of these capabilities are especially important when there is a combination of medium to long operation lead times, a significant labor component of cost, many operations, and bottleneck operations.

Routing operations may not be necessary when:

- Item lead times are very short.
- Total item costs consist mostly of material and overhead and the labor component is relatively small.
- Capacity can be easily managed.
- Repetitive module is not used.

Figure 3.1 summarizes the steps required to set up routings.

**Fig. 3.1**  
Routing Setup Workflow

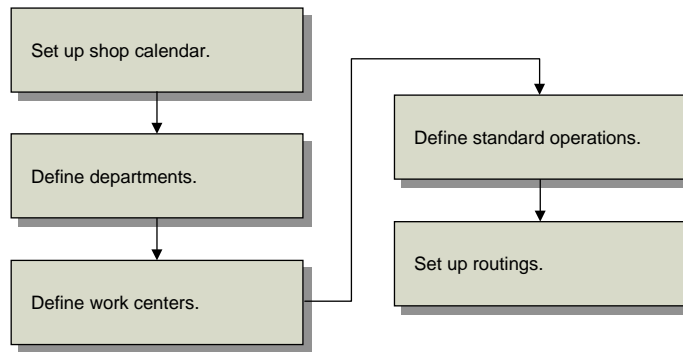

**Important** Work centers and operations work in conjunction with the shop calendar, which determines the work days and hours for the plant. Use Calendar Maintenance (36.2.5) to add work center-specific calendars. Before you begin defining the elements needed to create routings, make sure you set up the shop calendar. See *User Guide: QAD System Administration* for more information on calendars.

## Departments

A department groups similar work centers. Departments are like product lines because they are used to organize information on planning reports and to determine the GL accounts on transactions. Each department is set up with a fixed daily labor capacity and a set of GL accounts.

**Example** A manufacturer of sunglasses has a department for lens fabrication with several work centers for lens grinding and lens polishing. A separate department does lens coating.

The department load reports in the Capacity Requirements Planning (CRP) module use the department labor capacity when calculating the total department capacity for a period of time. The labor capacity should correspond to the sum of the total capacities of all work centers in the department.

See Chapter 14, “Capacity Requirements Planning,” on page 285.

Department account codes are similar to the GL account codes for product lines. They are used:

- When reporting labor and downtime in the Shop Floor Control and Repetitive modules
- When backflushing inventory and closing the accounting for completed work orders

A department code is independent of the GL accounts, sub-accounts, and cost centers defined for it. In the General Ledger module, cost center codes are often used to organize transactions by department. However, you do not have to use the same code for the cost center and department.

Table 3.1 lists the accounts for a department, the account type, and the transactions where the account is used. All department accounts must be of GL type Standard.

**Table 3.1**  
Department GL Accounts

Account	Type	Use
Cost of Production	Expense	Non-Prod Labor, SFC Transfer
Labor (Absorbed)	Expense	SFC, Repetitive, WO Close
Burden (Absorbed)	Expense	SFC, Repetitive, WO Close
Labor Usage Variance	Expense	SFC, Repetitive
Labor Rate Variance	Expense	SFC, Repetitive, WO Receipt
Burden Usage Variance	Expense	SFC, Repetitive
Burden Rate Variance	Expense	SFC, Repetitive, WO Receipt

Use Department Maintenance (14.1) to set up departments. You must define at least one department before setting up work centers or routings.

Account numbers default from Domain/Account Control (36.9.24). The Default Sub-Account/Cost Center and Override fields let you enter the same sub-account or cost center code for all accounts in a department. These fields are useful if you use standard account codes, but differentiate departments with sub-accounts or cost centers.

**Fig. 3.2**  
Department Maintenance (14.1)

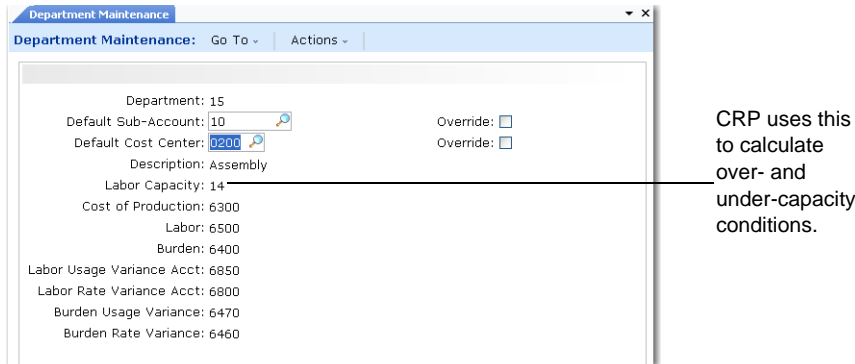

## Work Centers

A work center is a group of people and/or machines. Work centers also link departments with routing operations.

Work centers are the basic unit for operation scheduling and CRP. Depending on how you plan and schedule work, you can set up work centers for an individual machine or for groups of similar machines. If, for example, there are separate machines for polishing plastic lenses and polishing glass lenses, they would be set up as separate work centers. The system uses work centers for scheduling, planning, and determining costs for GL transactions.

Use Work Center Maintenance (14.5) to set up work centers.

**Fig. 3.3**  
Work Center Maintenance (14.5)

The screenshot shows the 'Work Center Maintenance' form with the following fields and values:

- Work Center: 100-01 | Machine:
- Description: Assembly
- Department: 100 | Assembly Dept.
- Auto Firm:
- Last Auto Firm:
- Scheduler ID:
- Queue Time: 2.0
- Wait Time: 1.0
- Mach/Op: 2
- Setup Crew: 2.00 | Setup Rate: 12.00
- Run Crew: 5.000 | Labor Rate: 10.00
- Machines: 3.000 | Labor Burden Rate: 5.00
- Mach Bdn Rate: 2.00 | Labor Bdn %: 3.00%
- Time Period: Horizon End: DAY | Period Number: 5 | Calculate Date: 1/19/2011

**Work Center and Machine.** Uniquely identify a work center by a work center code along with an optional machine code. Leave Machine blank if only one type of machine is in the work center. If there are multiple machine types or models, set up a different record for each machine, using the same work center ID.

**Department.** Enter a department code, set up in Department Maintenance (14.1). You must assign each work center to a department.

**Auto-Firm.** Specify Yes to have the system automatically firm orders scheduled on this production line using Auto Firm Planned Orders (22.20.1). Auto Firm Planned Orders firms planned orders for either production lines or work centers for a specific horizon or a range of dates.

If you use the .NET UI-only Planning and Scheduling Workbenches, you must set this field to Yes if you schedule for work centers and intend to firm planned orders in the workbenches. You must set the same-named field to Yes in Production Line Maintenance (18.1.1) if you intend to firm planned orders for production lines using the workbenches. If Auto Firm is set to No, the system does not firm planned orders.

**Last Auto Firm.** Enter a date of the last auto-firm by selecting a date from the calendars that display when you click the drop-down icon in the .NET UI. You can see the date of the last auto-firm in work center and production line browses in QAD EE.

**Queue and Wait Time.** Enter the standard time, in decimal hours, a job normally spends waiting at this work center before it is set up and processed and after processing has been completed. These values display as defaults when you reference this work center as part of a standard, routing, or process operation.

**Machines/Op.** Enter the number of machines at this work center that can work at the same time to process a given operation. CRP uses this number to calculate work center capacity. This value displays as the default when you reference this work center as part of a standard, routing, or process. See “Work Center Capacity” on page 23.

*Setup and Run Crew.* Optionally, enter the number of people required to set up and run this work center. These fields are for reference only.

*Machines.* Enter the number of machines or people in this work center. CRP calculates the total capacity for a work center by multiplying the number of working hours, defined in the shop calendar, by the number of machines.

*Setup and Labor Rate.* Enter the average labor rates paid per labor hour to set up and run this work center. These values are used by item cost calculations and by labor feedback functions to calculate and post actual costs and variances.

**Note** Rates apply to all operations carried out at this work center. You cannot change them for individual operations.

*Mach and Labor Burden Rate.* Enter the burden rates per hour applicable to machine and labor run time and setup at this work center. These values are used by item cost calculations and by labor feedback functions to calculate and post actual costs and variances.

*Labor Burden %.* Enter the labor burden percentage applicable to the total labor cost at this work center.

*Horizon End.* Specify either Day, Week, or Month as the horizon end for this work center. This field is applicable only when Planning and Scheduling Workbenches are enabled in Site Maintenance.

Work centers display as resources within the Planning and Scheduling Workbench, which is a .NET UI only scheduling tool for both master schedules and production schedules. The workbench depicts the scheduling or sequencing horizon, depending on your order type and which schedule (master or production) with which you work in the workbench. You can change the future and history horizon within the workbench; however, the date you set here depicts the increment for the horizon end.

The calculate date is read-only. The system calculates the date from period and period number, so if you set Horizon End to Day and Period to 5, the Calculate Date is 5 days starting with today. If you set Horizon End to Week and Period to 4, then the Calculate Date is 4 weeks from now including today.

*Period Number.* Specify the number of periods to use for the scheduling horizon for this work center. This field is applicable only when Planning and Scheduling Workbenches are enabled in Site Maintenance.

Work centers display as resources within the Planning and Scheduling Workbench, which is a .NET UI only scheduling tool for both master schedules and production schedules. The workbench depicts the scheduling or sequencing horizon, depending on your order type and which schedule (master or production) with which you work in the workbench. You can change the future and history horizon within the workbench; however, the period number you set here depicts the number of periods for the horizon.

*Calculate Date.* The calculate date is read-only. The system calculates the date from period and period number, so if you set Horizon End to Day and Period to 5, the Calculate Date is 5 days starting with today. If you set Horizon End to Week and Period to 4, then the Calculate Date is 4 weeks from now including today.

**Important** Changes to work center labor and burden fields affect how transaction amounts and product costs are calculated. They should be authorized by your cost accounting department.

## Work Center Capacity

CRP uses work center capacity when evaluating work center load. It is the total number of hours the work center is available to do work. Capacity varies with the work center calendar or shop calendar and the number of machines or people in the work center.

The formula is:

$$\text{Work Center Capacity} = \text{Calendar Hours Available} * \text{Machines}$$

The work center number of machines should be at least as high as the number of machines per operation for this work center and for operations that use this work center.

## Standard Operations

Often, routings share one or more operations that are essentially the same. For example, an automated packaging process may be the same regardless of the color of the products packaged. To save work when entering new routing operations, you can create template steps called *standard operations*.

When you enter a new routing operation, automatically copy the standard data to the routing by referencing the standard operation code. Then edit the standard information as needed. Changes apply only to the new routing—not to the standard operation you copied.

**Note** If you change a standard operation after referencing it on a routing, the changes do not automatically apply to the existing routing. Use Routing Update (14.13.7) to apply any changes you made to standard operations and work centers to existing routings.

Use Standard Operation Maintenance (14.9) to set up standard operations.

**Fig. 3.4**  
Standard Operation Maintenance (14.9)

, Inventory Value: 0.00, Subcontract Cost: 0.00, Subcontract LT: 0, Overlap Units: 0, and Comments: ."/>

**Work Center and Machine.** Enter codes for the work center and machine that normally perform this operation.

**Setup, Run, and Move Time.** Enter the normal times, in decimal hours, to process items during this operation. Run time is per unit; setup and move time are independent of order size. See “Lead Times” on page 27.

*Yield %.* Enter the order percentage expected to be in usable condition after this operation. See “Yield” on page 29.

*Tool Code.* Optionally, enter the code for a tool normally used during this operation. This is for reference only. To standardize tool codes, set them up in Generalized Codes Maintenance (36.2.13) for field ro\_tool.

*Supplier.* If this is a subcontract operation, enter the code of the supplier doing the work.

*Milestone Operation.* Enter Yes to define this as a repetitive labor reporting operation and to backflush all previous operations since the last milestone operation. The field only affects repetitive manufacturing operations. See Chapter 9, “Repetitive,” on page 171.

*Inventory Value.* Optionally, enter accumulated cost through this operation. Only this value is used by the Repetitive WIP Cost Report (18.4.12).

*Subcontract Cost and LT.* If this is a subcontract operation, enter the normal average cost per unit charged by the subcontractor and the normal number of calendar days the subcontractor takes to complete the operation.

*Overlap Units.* Enter the number of units that must be completed before they are moved to the next operation. When there are two consecutive operations, you can sometimes save time by moving partial quantities from one operation to the next before the first operation has been completed.

## Operation Capacity

As the number of machines increases, work center capacity and the number of hours a work center is available for work also increases. If there are 8 hours in a work day and an operation has 2 machines per operation, the work center has 16 hours of capacity for that operation.

$$\text{Operation Capacity} = \text{Calendar Hours Available} * \text{Machines per Operation}$$

The number of machines per operation is also used for calculating the lead time and machine burden cost for an operation.

## Routings

A routing consists of one or more operations—steps needed to make an item. Each operation is identified by a routing code and an operation number.

**Fig. 3.5**  
Routing Maintenance (14.13.1)

The screenshot shows the 'Routing Maintenance' window with the following fields and values:

- Routing Code: 20005
- FG20005
- Operation: 10
- Start Date: 02/22/2007
- End Date:
- Standard Operation:
- Work Center: ROUT-WC1
- Routing Work Center 1
- Machine:
- Description:
- Machines per Operation: 1
- Milestone Operation:
- Overlap Units: 0
- Subcontract LT: 0
- Queue Time: 0.0
- Setup Crew: 0.00
- Wait Time: 0.0
- Run Crew: 1.00
- Setup Time: 0.0
- Tool Code:
- Run Time: 0.0
- Supplier:
- Move Time: 0.0
- Inventory Value: 0.00
- Start Date: 02/22/2007
- Subcontract Cost: 0.00
- End Date:
- Comments:
- Yield Percent: 100.00%

Many of the fields in Routing Maintenance are the same as in Standard Operation Maintenance (14.9). Additional fields are described below.

See page 23.

**Routing Code.** This is typically the same as the item number, but routing codes and item numbers are entirely independent. This allows the same routing to be used for multiple items. One item can also be made using one of several routings. See “Alternate Routings” on page 26.

A matching item number and routing code are automatically linked to each other. When an item’s routing code is blank in the item or item-site planning data, the system uses the item number as the routing code. If they are different, specify the routing code in Item Planning Maintenance (1.4.7) or Item-Site Planning Maintenance (1.4.17).

**Operation.** Each routing consists of a series of steps. Enter a number to identify this step within this specific routing code. Operation numbers must be unique within a routing. Routing operations are always printed in ascending sequence by operation—operation 20 follows operation 10. Number by 10s or 100s, so you can add new intermediate steps without renumbering existing ones.

At least one operation is required to process repetitive labor feedback.

**Start and End Date.** Optionally, define effective dates for this operation. This lets you phase in engineering changes and maintain history online.

Functions that reference the routing always use the routing steps in effect on the current date. Most reports and inquiries can be selected for a specific effective date.

**Standard Operation.** Enter the code for the standard operation to use as the basis of this operation step. Many values then default from that standard operation. You can then modify them as needed to create the specific operation for this routing. See “Standard Operations” on page 23.

**Machines per Operation.** Enter the number of machines that can process work at the same time at this operation. This value defaults from the work center machines per operation.

**Queue and Wait Time.** Enter the times, in decimal hours, a job normally waits at this work center before this operation is set up and processed and after this operation has been completed.

**Setup and Run Crew.** Enter the number of people normally required to set up and run this operation. These fields are for reference only.

**Fig. 3.6**  
Routing Maintenance (14.13.1)

**WIP Item.** Optionally, enter an item number to represent work-in-process material for subcontract shipments. This field is used by Sub Shipper Print (18.22.5.9) when processing repetitive subcontracts. The description and unit weight of the WIP item display on the subcontract shipper.

**Move Next Op.** Enter Yes or No to determine the default for the same field in Backflush Transaction (18.22.13) and Move Transaction (18.22.19).

**Auto Labor Report.** This field is used in the Advanced Repetitive module to determine if standard labor is reported automatically by Backflush Transaction (18.22.13). See “Automatic Labor Reporting” on page 125 for details.

## Alternate Routings

After you enter a routing, you can link it to an item in several ways, depending on whether it should be used as the default routing code or available for use as an alternate routing.

- If the routing should be the default for an item, update the routing code in Item Planning Maintenance (1.4.7). This is the routing code used for CRP, work orders, repetitive, and costing.
- If the routing should be the default for an item at a particular site, update the routing code using Item-Site Planning Maintenance (1.4.17). This is the routing code used for CRP, work orders, repetitive, and costing for an item at a site. It overrides the routing code set up in Item Planning Maintenance.
- If the routing should be available as an alternate for an item at any site but not used as the default, use Alternate Routing Maintenance (14.15.1) to link it with an item. This allows the routing code on a work order to be changed to this alternate routing.
- If the routing should be available as an alternate for an item at a specific site, use Alternate Routing Maintenance to link a routing code to an item-site. This allows the routing code on a work order to be changed to this alternate routing.

## Work Center Routing Standards

Sometimes work is actually performed at a different work center than appears on a routing operation. If the work center where the work was completed has different equipment, it may not be meaningful to compare actual hours with standard hours calculated using the normal work center.

When alternate work centers can be used for specific operations, you can use Work Center/Routing Standards Maintenance (14.17.1) to record the expected run times for the alternate work centers. This cross-reference is used for reporting actual run times on efficiency reports in the Repetitive module.

## Routing Cost Roll-Up

Use Routing Cost Roll-Up (14.13.13) to update the costs for items based on their routing (process) operations. This function can also update the Yield % field in the item planning data based on rolling up the percentages associated with each routing operation.

For details on costing, see *User Guide: QAD Costing*.

## Lead Times

Lead times for operations and manufacturing are expressed in terms of several components.

**Fig. 3.7**  
Lead Time Components

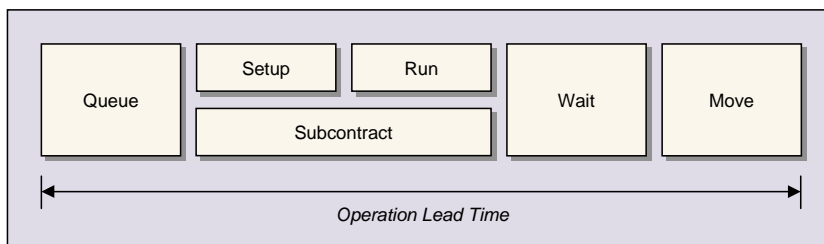

- **Queue.** Amount of time a lot must wait at a work center before the operation is set up and production begins. Occurs when there is a backlog of jobs at a work center and is frequently the single longest component of manufacturing lead time.
- **Setup.** Time required to prepare a work center to process a lot or batch quantity for a specific operation.
- **Run**
  - In Routing Maintenance (14.13.1), the average time required to manufacture a single unit.
  - In Process Definition Maintenance (15.13), the average time to process an entire batch.
  - In Routing Maintenance (Rate Based) (14.13.2), run time is expressed in terms of an hourly production rate.

In all cases, the system stores run time internally as the run time per unit.

- **Wait.** Amount of time a lot or batch must remain at a work center after production is completed before it can be moved to the next operation.
- **Move.** Time a lot or batch spends in transit from one operation to the next.
- **Subcontract.** Number of days required for an outside supplier to process the lot.

## Operation Lead Time

Planning programs use these lead times to determine the duration of an operation and the time between successive operations. The amount of time a work center is actively involved in producing an item is determined by setup, run, and subcontract times. The time between operations—interoperation time—is determined by queue, wait, and move times. Most of these times are stated in hours, except for subcontract, which is stated in days.

The operation lead time is calculated using each of the lead time components, the number of machines per operation, and the item order quantity. The work center or shop calendar is used to convert queue, setup, run, and move times from hours to manufacturing days.

$$\text{Operation LT} = \frac{\text{Queue} + \text{Setup} + \text{Move}}{\text{Hours Available}} + \frac{\text{Run} * \text{Order Quantity}}{\text{Hrs. Avail.} * \text{Mach. per Op.}} + \frac{\text{Wait}}{24} + \text{Subcontract LT}$$

If you examine this formula, several concepts become apparent:

- Queue, setup, and move times are completely independent of the order quantity or lot size.
- Queue, setup, and move times are also independent of machines per operation, since these do not require that a machine be available.
- Queue, setup, and move times are a function of available work center or shop calendar hours since the operation can only be performed during working hours. If queue, setup, and move times add up to 16 hours and there are 8 working hours in a day, 2 manufacturing days are needed.
- The total run time for an operation is a function of order quantity. If the unit run time is 1 hour and the item order quantity is 48, a total of 48 hours of run time is needed.
- The run time for an operation is a function of total run time, work center or shop calendar hours, and the machines per operation. If a work center is open for 8 hours per day and there is one machine per operation, run time is 6 manufacturing days (48 hours over 6 days with 8 machine hours per day). However, if there are 3 machines per operation, run time will take only 2 days (48 hours over 2 days with 24 machine hours per day).
- Wait time is the amount of time a lot must remain at a work center after an operation is completed before it can be moved to the next operation. It is calculated from a straight 24-hour clock, since no machines or people are required.
- Subcontract lead time is stated in days. It is added directly to the other lead time components.

The system schedules work order and repetitive operations sequentially, assigning start and due dates for each operation. The duration of a specific operation—the time between its start date and due date—is determined by the setup, run, and subcontract times for the operation. The interoperation lead time—the time between the due date of one operation and the start date of the next operation—is calculated using the first operation's wait and move times and the following operation's queue time.

**Note** Setup and run times are used for operation scheduling, lead time calculations, product costing calculations, and GL transactions created by activities such as reporting labor and completing repetitive operations in the manufacturing modules. Changes to setup and run times should be coordinated to prevent adverse effects in any one of these areas.

## Manufacturing Lead Time

The manufacturing lead time for an item is the sum of its operation lead times, stated in manufacturing days. Capacity planning uses manufacturing lead time, in conjunction with the work center or shop calendar, to determine order release dates.

There may be differences between operation schedules for an order and the manufacturing lead time for an item due to any one of several reasons:

- The item order quantity used to calculate the manufacturing lead time may be different than the actual order quantity for an operation, resulting in differences in the run time for an operation.
- The shop and/or work center calendars may be scheduled for more (or less) hours than the default calendars used to calculate manufacturing lead time.
- Queue time for the first operation does not affect its start date; therefore, it may fall after the release date of an order.
- Two successive operations may overlap.

## Subcontract Operations

Some operations may be performed by an outside supplier or subcontractor rather than by a work center. This requires some special setup, particularly if you want to include subcontracted operations in supplier load and capacity reports.

Set up at least one department for outside processing and a separate work center for each type of subcontract operation. Each supplier or type of subcontract operation should have at least one work center defined for it. This lets you specify the work center on dispatch reports, which provide visibility of upcoming operations.

Set the work center labor and burden rates to zero to prevent GL transactions from being created. You can express work center lead times in subcontract days if load reporting is not a requirement. Otherwise, use queue, setup, run, wait, and move times in conjunction with a work center calendar.

You can also add one or more departments for specific suppliers for whom capacity is a major concern. Review capacity for these departments by printing the department load reports in the CRP module.

See “Managing Subcontracting” on page 148.

## Yield

Operation and item yield are different than the component scrap percentage in product structures. Component scrap results in additional requirements for individual components of a parent item. When an item’s yield is less than 100 percent, MRP creates additional scrap requirements for the item, causing the item and all of its components to be overplanned. Depending on the manufacturing process, the percentage of a lot expected to be of acceptable quality may also fall below 100 percent.

The system can calculate the total yield for an item in two ways, based on the values in two item planning data fields: Yield % and Op Based Yield.

See “Scrap” on page 11 for a more detailed description of how the component scrap percentage is used.

## Yield Percent

MRP can use the item yield percentage to plan additional supply. Using this method, the expected yield for an operation can be expressed as:

$$\text{Yield} = \text{Acceptable Units at Operation End} * 100$$

The total manufacturing yield for a product is determined by multiplying the yield percentages for each of its operations.

$$\text{Manufacturing Yield} = \text{Yield \% for Op10} * \text{Yield \% for Op20} * \dots$$

Take care when setting yield to anything but 100 percent—particularly when yield is used for multiple operations.

**Example** For four operations, each having a yield of 90 percent, the system calculates the item yield according to the following calculation:

$$90\% * 90\% * 90\% * 90\% = 66\%$$

This equation includes an expected loss of one in three units. If MRP plans this item for a demand of 100 units, the system creates a scrap requirement for 51 units and a planned order for 151 units, based on the following formula:

$$(100 / 66\%)$$

With standard yield percentage, all component quantities use the same 66 percent item yield when MRP derives component requirements. For example, if this item has a requirement for one each of four components, each with a product structure quantity per of 1, MRP determines that 151 units are required for each component item, based on this calculation:

$$(100 * 1) / 66\%$$

## Operation-Based Yield

The system also supports yield calculation for component requirements based on individual operations within a parent item’s routing. To use this method, you must:

- Set Op Based Yield to Yes in Item Planning Maintenance (1.4.1 or 1.4.7) or Item-Site Planning Maintenance (1.4.17).
- Set Enable Op Based Yield to Yes in MRP Control (23.24).

When operation-based yield is in effect, the Yield % field associated with the item is not used to determine component requirements.

Operation-based yield affects the explosion of bills of material in work orders, repetitive, advanced repetitive, and configured products, as well as MRP.

Using this method typically results in more accurate calculations and prevents overplanning of components. This is especially true in a mature process where yield percentages are highly predictable.

**Example**

When subassemblies are scrapped at earlier operations, operation-based yield lessens component quantities required for later operations. Consider the following example:

- An order for 100 ITEM-A is entered in the system.
- ITEM-A has four components: COMP-1, COMP-2, COMP-3, and COMP-4.
- The quantity required for each component is one unit per completed assembly.
- Four operations are needed to build ITEM-A and one component is used at each operation. The first component is used at the first operation, the second component at the second operation, and so on for each component.
- Each operation has a yield of 90 percent.

Based on the demand for 100 ITEM-A, MRP generates a planned order for 151, based on the following calculations:

$$\text{Item Yield} = (90\% * 90\% * 90\% * 90\%) = 66\%$$

$$\text{Planned Order Quantity} = 100 / .66 = 151 \text{ of ITEM-A}$$

The system uses the same calculation for the parent item regardless of the yield calculation method in effect. However, when calculating component requirements, the different methods yield different results, as illustrated in Table 3.2.

**Table 3.2**  
Operation-Based Yield Example

Operation	Component	BOM Qty	Op Yield	Eff Yield	Op Based Yield	Op Based Yield
					Yes Comp Qty Req	No Comp Qty Req
10	COMP-1	1.0	90%	100%	151	151
20	COMP-2	1.0	90%	90%	135	151
30	COMP-3	1.0	90%	81%	122	151
40	COMP-4	1.0	90%	73%	110	151

Because Operation 10 is the first operation, it requires 100 percent of the components. When Op Based Yield is No, the component quantity is calculated from the yield percentage of the parent item. The system applies the same 66 percent item yield to each operation to determine component requirements of 151, according to the formula:

$$(100 * 1) / 66\%$$

When Op Based Yield is Yes, the system uses the yield percentages of the parent’s operation records to determine component quantities. Operation 10 has an effective yield of 90 percent. It is anticipated that 10 percent of the parent items are scrapped at this operation.

As a result, only 135 (151 \* 90%) parent items are input to operation 20 and only 135 COMP-2 items are needed (135 \* 1). Operation 20 also has a 90 percent yield. As a result, only 90 percent of the 135 parent items (122 units) survive to operation 30. This means only 122 COMP-3 items are required, and so on.

As this example indicates, operation-based yield calculation can have a dramatic effect on the requirement for the components associated with the final operations in a manufacturing process.

**Important** Operation-based yield modifies only the quantity planned for production. It does not modify the quantity of components consumed by work orders.

# Formulas and Processes

The Formula/Process module defines and maintains the relationships between products, ingredients, and materials, as well as the processes required to manufacture a product in a batch.

## ***Introduction*** 34

Outlines the Formula/Process Module and describes its relationship to batch numbers and lot control.

## ***Defining Formulas*** 34

Describes how Formula Maintenance can be used to define new formulas and introduces additional fields to use with batches and items.

## ***Defining Processes*** 36

Describes how Process Definition Maintenance can be used to define control information in terms of batches and introduces additional fields to use with processes.

## Introduction

A formula (or recipe) is another way to define a product structure. A process definition is identical to a routing. In fact, there is no difference to the system between defining a set of operations in Routing Maintenance (14.13.1) or Process Definition Maintenance (15.13). Before you set up a process definition, you must set up the shop calendar, departments, and work centers.

See Chapter 3, “Routings and Work Centers,” on page 17.

**Fig. 4.1**  
Formula/Process Module

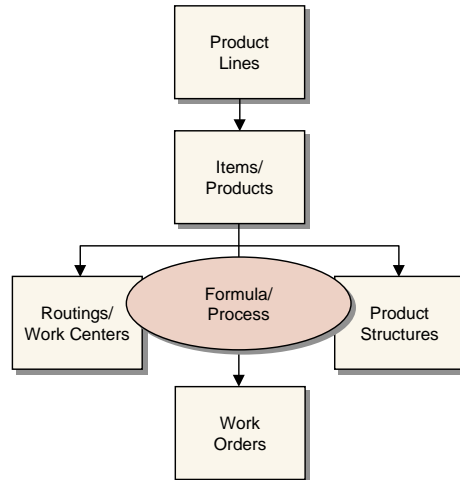

While Routing Maintenance sets up operation run time in hours per unit, and Routing Maintenance (Rate Based) (14.13.2) in terms of units per hour, Formula/Process lets you define a formula in terms of batch size and process it in hours per batch. The batch size is expressed in the parent item’s unit of measure and represents the quantity in which the item is to be produced.

In Formula/Process, all definitions reference a specific batch size. You can specify ingredient quantities as a quantity per batch or as percent of a batch. Process definitions are always expressed as run times per batch. Unlike product structures, formulas relate to a particular batch size.

The Formula/Process module also manages processes that create co-products and by-products, along with the base process that produces them.

See Chapter 5, “Co-products and By-products,” on page 39.

The Formula/Process module works in conjunction with lot/serial control, which is sometimes necessary to comply with government regulations. Lot control can also help companies improve quality, process control, and inventory accuracy.

## Defining Formulas

Formulas are defined as parent item/component relationships. To define a formula for a product, enter the product as the parent, and the formula ingredients as components of the product.

Once a formula has been defined for a particular product, that product can produce a higher-level product. This is typical of a master batch or an oven heat, which processes other items.

When discrete components are issued—such as packaging and labels—closing the process batch work order and issuing the batch to a discrete packaging work order can be useful. The system offers process, discrete, and model/option work orders, or paperless repetitive scheduling in a single environment. You can backflush components for any of these types of production scheduling.

A formula—sometimes called a recipe—defines the ingredients for a manufactured item. Use Formula Maintenance (15.5) to define formulas. The system automatically assigns the item number to the BOM.

**Fig. 4.2**  
Formula Maintenance (15.5)

The screenshot shows the 'Formula Maintenance' window with the following data:

- Parent Item: BRACKBCT4-None-00
- Description: Bumper Rack for BCT4
- Batch Size: 1 EA
- Component Item: APS-1111
- Component: 1111
- Rev: (blank)
- Reference: (blank)
- Effective Date: (blank)
- To: EA
- Quantity per Batch: 0.0
- Quantity Type: B
- Batch Percent: 0.0
- Structure Type: (blank)
- Start Effective: (dropdown arrow)
- End Effective: (dropdown arrow)
- Remarks: (text area)
- Scrap: 0.00%
- Lead Time Offset: (text field)
- Operation: (text field)
- Sequence Number: (text field)
- Forecast Percent: 100.00%
- Option Group: (text field)
- Process: (text field)

This program is very similar to Product Structure Maintenance. Only additional fields are described here.

See page 11.

**Batch Size.** A system-maintained field recording the normal batch size for an item. If a formula code has been defined for the item in Formula Code Maintenance (15.1) or Process/Formula Maintenance (15.18), the batch size displays from that record. Otherwise, the system displays the value from Item Master Maintenance (1.4.1).

**Quantity Type.** Specify how the component or co-product/by-product quantity is used for this formula or base process.

- Blank: parent unit of measure. Defines quantity in terms of a single unit of the parent, in the parent's unit of measure. For example, if the unit of measure of ink is liters and the quantity per of ink concentrate is 10g, 10 grams of concentrate are needed for each liter of ink.
- B: standard batch size. Defines quantity in terms of the parent's batch quantity. For example, if the batch size of ink is 50 liters and the quantity per of ink concentrate is 10g, 10 grams of concentrate are needed for each batch.
- P: percentage of batch. Defines quantity as a percentage of batch, specified in Batch Percent field. For example, if batch size of ink is 50 liters and water makes up 90% of the batch, 45 liters of water are needed for each batch.

**Note** If the batch and component quantities are not in the same unit of measure, set up a UM conversion.

**Batch Percent.** Enter the quantity of the component ingredient required to manufacture a batch of the parent item, expressed as a percentage of the batch. Use this field only if Quantity Type is P.

Use Formula Code Maintenance (15.1) to set up a BOM/Formula that is not an item number.

- **Site-specific formulas.** Set up a BOM/Formula for each required site. For simplicity, use the item number followed by site code. Then use Formula Maintenance to attach the ingredients list. Finally, use Item-Site Planning Maintenance to assign the normal BOM/Formula to each item-site. This designates the formula used for planning and manufacturing at that site.
- **Common formulas.** Several products can use exactly the same ingredients, the only difference being processing or aging. Set up a BOM/Formula and attach the formula to it. Then assign that BOM/Formula to each of the items in Item Planning Maintenance as the default formula.
- **Alternate formulas.** One item can have several formulas, common for different batch sizes. Set up a BOM/Formula for each batch size and attach the formula to that BOM/Formula. Associate these with each BOM/Formula as an alternate using Alternate Structure Maintenance, or link them to items and processes using Alternate Routing Maintenance. Designate one formula in Item Planning Maintenance as the default for planning.
- **Co-product/by-product formulas.** The BOM/Formula code or base process for a co-product/by-product structure is actually a component of the co-products and by-products that it produces. The unit of measure (UM) for the BOM/Formula when it is a base process item should be the same as the UM in the item master for the base process. See Chapter 5, “Co-products and By-products,” on page 39.

**Fig. 4.3**  
Formula Code Maintenance (15.1)

The screenshot shows a software window titled "Formula Code Maintenance". The window has a menu bar with "Go To" and "Actions". The main content area displays the following fields and values:

- BOM Code: BRACKBCT4-None-00
- Description: Bumper Rack for BCT4
- Batch Size: 1.0
- UM: EA
- Formula:
- Comments:

Formula Copy (15.8) creates a new formula by copying another one—useful when items share similar formulas or to create alternates.

If the destination structure already has components, the system displays a warning and prompts you to continue. Using the Combine Common Components field, you can choose to either combine or overwrite the existing item/quantity components being transferred from the source to the destination structure.

After copying, use Formula Maintenance to modify the new formula by adding, deleting, or changing requirements.

## Defining Processes

A process, like a routing, is a sequence of steps to follow in the production of an item. A process definition, however, defines its control information in terms of a batch rather than a completed unit.

Process Definition Maintenance (15.13) is very similar to Routing Maintenance. Only a few fields are different.

See page 25.

**Fig. 4.4**  
Process Definition Maintenance (15.13)

**Batch Quantity.** A system-maintained field recording the normal batch quantity for an item. If the formula was entered in Formula Maintenance, Batch Quantity defaults from the item master. Otherwise, it defaults from Formula Code Maintenance. Use Batch Quantity Change (15.9) to change the value.

Ingredient quantity per and process operation run times are stated in terms of this batch quantity.

**Run Time/Batch Qty.** Enter the process operation run time in terms of the batch quantity for the item.

To save data-entry time when defining processes for items that share similar operations or when creating alternates, copy an existing definition record with Process Definition Copy (15.16). Then add, change, or delete operations as needed.

## Process/Formula Maintenance

Process/Formula Maintenance (15.18) lets you enter formula, batch, process, and co-product/by-product information from a single menu program. This is particularly useful when you are setting up processing for co-products/by-products.

See Chapter 5, “Co-products and By-products,” on page 39.

**Fig. 4.5**  
Process/Formula Maintenance (15.18)

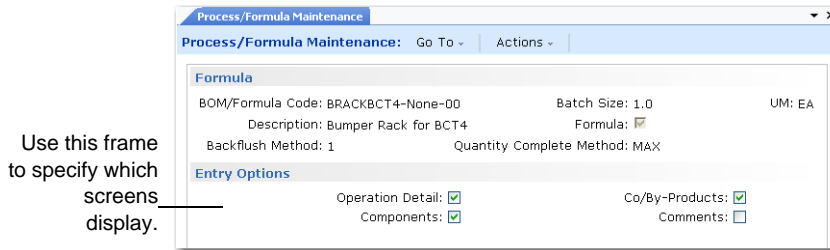

There are four main screens, in addition to a transactions comments screen:

- The Formula/BOM Code screen records the code for the parent item. It is the same as Formula Code Maintenance (15.1).
- The Process Operation Detail screen records information about the operations associated with the formula's process definition. It is the same as Process Definition Maintenance (15.13).
- The Formula Components screen records information about the components used at each operation. It is the same as Formula Maintenance (15.5).
- The Co/By-Products screen records information about co-products and by-products. This is the same as Co/By-Product Maintenance (15.12.1). See "Setting Up a Co/By-product Structure" on page 45.

# Co-products and By-products

These topics describe how to manage processes that create more than one product. Topics related to material requirements planning (MRP) and work orders for co-products and by-products are also discussed.

***Introduction to Co-products and By-products* 40**

Defines co-products and by-products and outlines some of the features and manufacturing options they support.

***Setting Up a Co/By-product Operation* 43**

Describes how to set up a typical operation with co-products or by-products.

***Calculating Costs and Lead Times* 50**

Describes how the system calculates co-product costs and lead times differently from those of by-products, as well as average and overall cost accounting.

***MRP for Co-products/By-products* 56**

Describes how and why to avoid overplanning for some items during setup.

***Managing Joint Work Order Sets* 59**

Defines Joint Work Order Sets and discusses how to create, modify, and review them as well as how to deal with unexpected events.

***Restrictions* 70**

Outlines some categorical restrictions, including inventory, purchasing, repetitive, and advanced repetitive.

## Introduction to Co-products and By-products

You can use a special set of features for managing processes that create more than one product. Such products are referred to as co-products or by-products. Processes that create only one product are supported by regular bills of material (BOM) and formulas.

Co-product/By-product features support a variety of manufacturing operations, including:

*Batch processing.* Production of items by mixing, blending, and refining component ingredients, such as pharmaceuticals, processed foods, and wine.

*Sorting.* Separation of items by characteristics such as size, weight, or quality, such as clothing, computer chips, and produce.

*Disassembly.* Separation of items from larger items, such as juice and seeds from oranges.

*Molding.* Production of items using multiple-cavity molds such as plastics and confections.

Features include support for MRP, work orders, shop floor control, and costing, as well as tools for setting up items, structures, and routings. Great flexibility is provided in defining alternate products structures and routings. As a result, perhaps even more than with regular processes, careful planning is critical.

Implementing and managing co-products/by-products involves:

- Setting up an operation for co-products and by-products
- Developing standard and simulation costs
- Implementing material requirements planning (MRP)
- Managing the work order life cycle for the related products

### Concepts

A *base process* is a manufacturing operation that creates more than one product. These products are called *co-products* or *by-products*. For this discussion, a co-product is an intended result of a base process and generally has significant value. In contrast, a by-product is an incidental result of a base process. Figure 5.1 illustrates a typical base process that produces two co-products.

**Fig. 5.1**  
A Base Process Produces Multiple Products

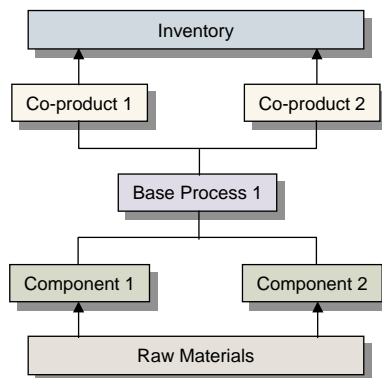

**Example** A sheet metal stamping process yields a piece of sheet metal used to make school bus window casings. The stamping process also yields two other products:

- Pieces of metal that are removed from the window hole and used to make seat brackets in another process
- Metal shavings that are swept up and disposed of at a cost

The pieces cut from the window hole have value, and are considered a co-product. The metal shavings have little value and an associated disposal cost, and are considered a by-product. If the shavings can be sold as scrap, the manufacturer may decide to define them as a co-product instead. See Figure 5.2.

**Fig. 5.2**  
Defining Co-products and By-products

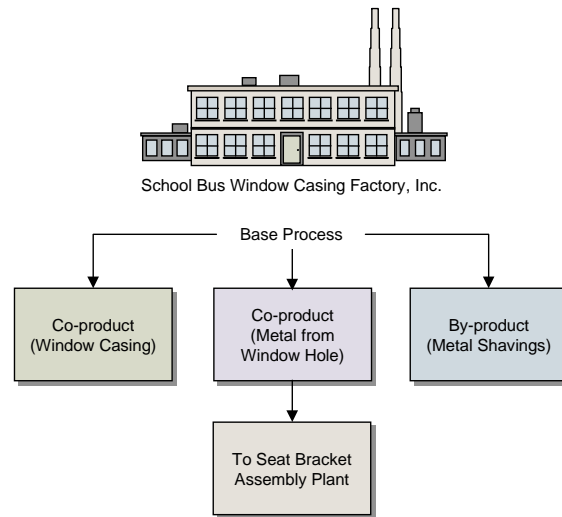

The co-products and by-products of a base process do not have their own product structures or routings. These are defined in the base process. Base processes are items containing formulas for co/by-product operations, and are defined in the same way as regular items. A base process has:

- An associated item record
- A product structure listing its co-products and by-products
- A formula (product structure) listing its component requirements (optional)
- A routing listing its operations (optional)

The BOM/formula code for a co-product is the item number of the co-product's base process.

There are some important distinctions between base process items and regular items:

- Base process items are never regarded as items to be stocked. Item status codes are used to restrict inventory transactions related to base process items and to ensure that these items never appear on sales or purchase orders. Should base process items end up in inventory, or on sales or purchase orders, they are ignored by MRP.
- Base process items cannot be used as components in another process.

Demand for co-products drives the planning of base processes, and the co-product that has the most demand is the one planned for.

**Example** Base process X produces two co-products, Y and Z. Since there is greater demand for Y than for Z, base process X is planned to produce the desired quantity of Y. The quantity of Z produced will therefore exceed demand.

A co-product can be a component of another process or product structure. For instance, for Company Q, nonvintage wine may be a co-product of the wine manufacturing process and a component of the wine cooler manufacturing process, as shown in Figure 5.3.

**Fig. 5.3**  
A Co-product Used as a Component in Another Structure

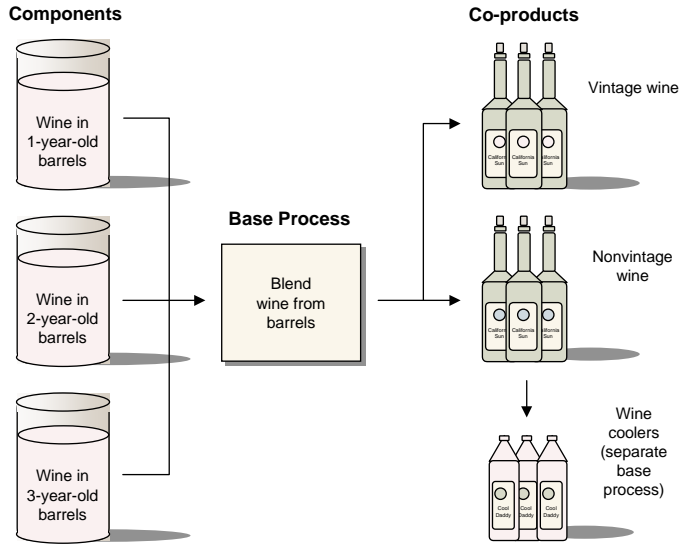

By definition, demand for by-products is not expected. If demand for a by-product is generated, MRP treats it as demand for a normal item. MRP does not plan work orders to satisfy by-product demand.

### Co-product/By-product Workflow

Figure 5.4 shows steps for setting up and managing a typical operation involving a base process with co-products and by-products.

**Fig. 5.4**  
General Workflow for Co-products/ By-products

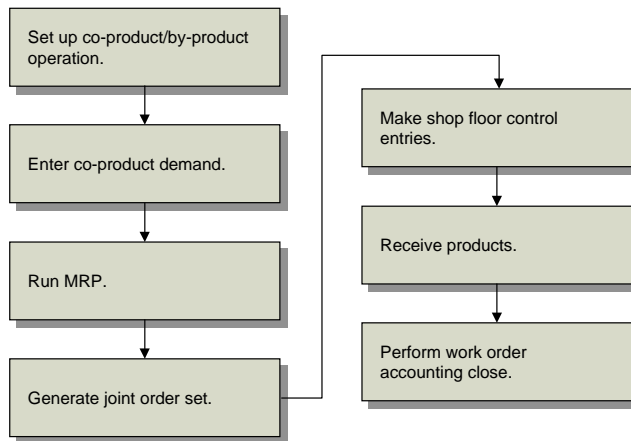

## Setting Up a Co/By-product Operation

Figure 5.5 shows steps for setting up a typical operation for co-products and by-products. Each step is discussed in detail in the following sections.

**Fig. 5.5**

Setting up for Co-products/ By-products

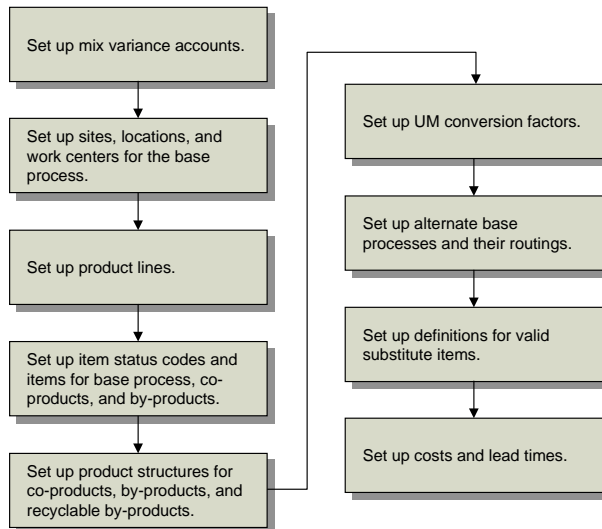

### Setting Up Mix Variance Accounts

If the quantity of a co-product or by-product received to stock differs from the quantity expected, a variance occurs. To record such variances properly, called *mix variances*, a Mix Variance account must be established. Even if you do not plan to use the co-product/by-product features, a Mix Variance account must be established before any work orders can be generated.

- 1 Set up Mix Variance accounts and, optionally, sub-accounts and cost centers in the General Ledger (GL) setup functions (25.3).
- 2 Verify that Mix Variance account numbers appear in the variances frame of Domain/Account Control (36.9.24).
- 3 Set up Mix Variance accounts for specific product lines in Product Line Maintenance (1.2.1).
- 4 Set up Mix Variance accounts for product lines at specific sites in Work Order Accounts Maintenance (1.2.9).
- 5 Associate product lines with co-products and by-products in Item Master Maintenance (1.4.1) or Item Data Maintenance (1.4.3).

Mix variances are generated when co-product and by-product work orders are processed by Work Order Accounting Close (16.21). Variance amounts are posted to the Mix Variance account on the applicable co-product or by-product work order and subtracted from the work-in-process (WIP) amount of the base process work order.

The work order close procedure can be performed more than once for a work order, and the variance amounts are cumulative.

For more information on mix variances, see “Calculating Mix Variances for Joint Orders” on page 65.

## Setting Up Sites and Locations for the Base Process

Establish sites for the base process in Site Maintenance (1.1.13). A location is an area within a site. A site can have an unlimited number of locations. You can use the same location code for different sites. Use Location Maintenance (1.1.18) to set up locations for the base process.

## Setting Up Work Centers

A work center is a production facility capable of performing a certain task. A work center might be a place, a machine or group of machines, a person or group of people. Work centers are the most basic units used for operation scheduling, capacity requirements planning, and cost determinations for GL transactions.

In Work Center Maintenance (14.5), set up work centers by entering for each a unique work center code and a unique machine code.

## Setting Up Product Lines

A product line is a group of similar items or products. At many companies, sales and operations are planned, reported, and analyzed by product line rather than by individual item or product. To establish a product line, use Product Line Maintenance (1.2.1).

## Setting Up Item Status Codes for the Base Process

Base process items are never stocked in inventory. As a result, although base processes are entered as regular items, they are not processed as inventory items. Use item status codes to prevent any inventory transactions related to base process items. Item status codes are created and maintained in Item Status Code Maintenance (1.1.5). Only two transactions should be allowed for the base item:

- ADD-PS, which occurs when the item is added to a product structure.
- ADD-WO, which occurs when the item is added to a work order.

## Setting Up the Base Process Item

1 Create a base process item in Item Master Maintenance (1.4.1). Enter the unit of measure for each batch. Assign an item status that restricts inventory transactions.

2 Enter the following information in the Item Planning Data frame.

*Batch Qty.* This is established in Formula Code Maintenance (15.1) or Process/Formula Maintenance (15.18)

*Plan Orders.* Enter Yes

*Order Policy.* Enter POQ or FOQ. MRP does not use LFL or OTO for base processes.

*Pur/Mfg Code.* Enter M (manufactured) or leave blank.

*BOM/Formula.* Leave blank. A base process item cannot refer to another BOM/Formula.

*Phantom.* Enter No.

## Setting Up Items for Co-products and By-products

Create items for co-products and by-products using standard procedures. For co-products, it is important to set the BOM/Formula field equal to a base process item number.

In Item Master Maintenance (1.4.1), Item Planning Maintenance (1.4.7), or Item-Site Planning Maintenance (1.4.17), enter the following for each co-product and by-product of a given base process.

*Item Number.* Enter an item number for the co-product or by-product.

*Planning Parameters.* Normally, you accept default values for these fields. MRP does not use planning parameters for co-products. Instead, it uses the parameters of the base process. MRP does not plan the base process to satisfy demand for a by-product. Rather, it plans by-products using the conventional method.

*Pur/Mfg.* Leave blank or enter M (manufactured) for co-products. Enter any value for by-products.

*BOM/Formula.* Enter the item number for the base process normally used to produce this co-product or by-product. This field is used for planning, work orders, and cost roll-up. An item can be a by-product and have a normal BOM/Formula code.

**Note** For items that are always by-products, BOM/Formula codes are optional. Entering the base process item number as the BOM/Formula code for by-products and co-products enables you to sort MRP Summary and Detail Reports by BOM/Formula code.

*Routing Code.* This should be left blank in most cases. If a co-product has a preferred routing different from the base process routing, enter that preferred routing. This routing must be set up as an alternate routing for the base process.

*Phantom.* Enter No. A co-product can be a component in a regular product structure, but the structure type cannot be X (phantom).

## Setting Up a Co/By-product Structure

A co-product/by-product structure defines the items that result from a base process and specifies whether they are co-products or by-products. These product structures can be set up in several ways. The easiest way is through Process/Formula Maintenance (15.18), which combines the features of the following programs:

- Master Comment Maintenance (14.12)
- Routing Maintenance (14.13.1)
- Formula Code Maintenance (15.1)
- Formula Maintenance (15.5)

- Co/By-Product Maintenance (15.12.1)

- 1 Set up BOM/formula codes using Process/Formula Maintenance (15.18) or Formula Code Maintenance (15.1).

**Note** You can have the system create BOM/formula codes automatically when you define formulas and product structures.

*BOM Code.* Enter the base process item number.

*Batch Size.* Displays the batch quantity. The default is 0. To modify this field, use Batch Quantity Change (15.9).

*UM.* The BOM unit of measure. Should be the same as the item unit of measure for the base process item.

- 2 Set up the co/by-product structure using Process/Formula Maintenance (15.18) or Co/By-Product Maintenance (15.12.1).

*Backflush Method.* Enter 1 or 2. This determines the calculation method used to backflush base process components. See page 62.

*Quantity Complete Method.* Enter one of five valid calculation methods. This method determines how the expected co-product and by-product receipt quantities used to calculate variances for joint order sets are determined. The default is from Work Order Control (16.24). See page 65.

*Co/By Type.* Enter C for co-product or B for by-product.

*Quantity.* Enter the quantity per batch if Qty Type is Batch, or the quantity per base process unit if Qty Type is blank. The system calculates this field automatically when Qty Type is Percent.

*Qty Type.* Enter B for batch, P for percent, or leave blank to indicate per base process unit.

*Process.* Enter the percent per batch when Qty Type is Percent. This is calculated automatically when Qty Type is Batch.

*Cost Allocation.* Enter the percentage of base process cost to be allocated to this co-product. If Co/By Type is B, an allocation percentage cannot be entered.

Costs for co-products and by-products are calculated using the same programs that calculate regular costs. Once costs are rolled up for a base process (yielding gross cost), by-product costs are subtracted to arrive at the base process net cost. The entire net cost is then allocated to co-products of the base process. Allocation percentages for all co-products of a base process should add up to 100 percent.

See “Allocating Costs to Co-products” on page 50.

*Structure Type.* This field is display-only and always set to J (Joint).

- 3 Set up formulas or product structures used to define the ingredients or components required for a base process. You can use Process/ Formula Maintenance (15.18) or Formula Maintenance (15.5). To enter a product structure, use Product Structure Maintenance (13.5).

*Parent Item.* Enter the base process item number.

*Component Item.* Enter components of the base process item.

When adding a formula, you can enter a batch size. Use Batch Quantity Change (15.9) to modify a formula's batch size.

- 4 Set up routings for the base process using Process/Formula Maintenance (15.18), Process Definition Maintenance (15.13), or Routing Maintenance (14.13.1).
  - In Process/Formula Maintenance, enter the base process in the BOM/Formula Code field.
  - In Process Definition Maintenance or Routing Maintenance, enter the base process in the Routing Code field.

## Setting Up Structures for Recyclable By-products

A recyclable by-product is reused in a manufacturing process.

**Example** In a manufacturing process, dry paint is sprayed onto charged sheet metal. The paint powder adheres to the metal and, after baking in a kiln, becomes a painted surface. Upon application, some of the dry paint falls to the floor, where it is collected by a vacuum funnel and eventually returned to the spraying machine.

Although recyclable materials are technically by-products, the system does not treat them as part of the co-product/by-product structure, but as regular components. Thus, they should be defined as regular components and managed accordingly. Figure 5.6 illustrates a recyclable by-product process.

**Fig. 5.6**  
A Recyclable By-product Process

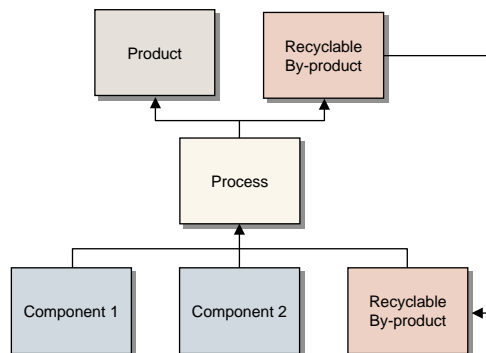

You set up a structure for a recyclable by-product by:

- Entering an item number for the recyclable item.
- Adding a recyclable item to a product structure/formula. Typically, you enter two product structure/formula records for each recyclable by-product:
  - One for the component requirement—a component going into the process—entered as a positive quantity.
  - One for a recyclable by-product—a component coming out of the process—entered as a negative quantity.

To set up a structure for a recyclable by-product, complete the following steps:

**1** In Item Master Maintenance (1.4.1), enter:

*Item Number.* Enter an item number for each recyclable by-product. Use a single item number even if the item requires reprocessing after it is received as a by-product and before it is reintroduced as an ingredient of a process.

**2** In Product Structure Maintenance (13.5) or Formula Maintenance (15.5), enter:

*Component Item.* Enter the item number of the recyclable material.

*Reference.* Enter a code to differentiate between a component requirement and a recyclable by-product. Typically, component requirements have blank reference codes. Recyclable by-product codes are user defined.

*Qty Per.* Enter a quantity for this product structure or formula. For a recyclable by-product, enter a negative number to indicate the quantity expected to be recovered from the process. For a component requirement, enter a positive number to indicate the full amount required.

*LT Offset.* Enter the number of days to be added to the work order start date to determine when the by-product is available for supply.

*Op.* Enter the operation for which the by-product is available or the operation for which the component is required.

Once these steps are complete, you can:

- Print work order picklists with component requirements summarized by operation.
- Roll up costs using the net material requirement for the component (quantity required less the quantity produced).
- Run MRP and have it recognize the demand and supply of the recyclable materials—by-product supply is negative demand.
- Receive by-products using Work Order Component Issue (16.10), Work Order Receipt Backflush (16.12), or Work Order Operation Backflush (16.19) for the operation where a by-product is expected, by entering a negative quantity to receive.

## Setting Up Unit of Measure Conversion Factors

When the base process unit of measure (UM) differs from the UM for a co-product or by-product, UM conversion factors must be defined. Conversions are from the base process UM to the co-product or by-product UM.

**Example** If the base process UM is liters and the co-product UM is kilograms, a UM conversion is required where the UM is liters and the alternate UM is kilograms.

Set up UM conversion factors in Unit of Measure Maintenance (1.13).

*Unit of Measure.* Enter the base process unit of measure.

*Alternate UM.* Enter the co-product or by-product unit of measure.

*Item Number.* Enter the base process item number, or leave blank.

*UM Conversion.* Enter the conversion factor converting quantities from Alternate UM to Unit of Measure.

## Setting Up Alternate Base Processes

An item can be a co-product or by-product of more than one base process. The base process for that item is its BOM/Formula code defined in Item Master Maintenance (1.4.1) or Item-Site Planning Maintenance (1.4.17).

Set up alternate base processes using Alternate Structure Maintenance (13.15).

*Item Number.* Enter the co-product item number.

*BOM/Formula.* Enter the base process item number.

## Setting Up Alternate Base Process Routings

Alternate routings are useful for managing variations in the manufacturing process of an item. For example, a substitute machine is used while the primary machine for a process is being repaired. Like routings for regular items, alternate routings for co-products are assigned when work orders are generated. Routings are not required and are not used in MRP or for developing standard costs.

Only a base process can have alternate processes or routings. This is not true for co-products and by-products because they do not have a formula or process independent of the base process.

Define alternate routings for a base process in Alternate Routing Maintenance (14.15.1).

*Item Number.* Enter the base process item number.

*Routing Code.* Enter the alternate routing number previously defined in Routing Maintenance (14.13.1) or Process Definition Maintenance (15.13).

*Bill of Material.* Leave blank.

## Setting Up Definitions for Valid Substitute Items

Receipt of items on joint work orders is not limited to items set up as co-products or by-products of a base process. Set Modify Co/By Product Receipts in Regulatory Attributes Control (1.22.24) to Yes to allow any item to be received on a joint work order. Set to No to have only valid substitutes received on a joint work order.

**Note** This feature is provided as a means of complying with FDA and other agency regulations. You can use co-products/ by-products without setting this field.

- 1 In Item Substitution Maintenance (13.19), do the following:

*Parent/Base Process Item.* Enter the base process item number or leave blank.

*Item Number.* Enter the co-product or by-product item number.

*Substitute Item.* Enter the item number of valid substitutes for the standard co-product or by-product.

- 2 For users who have the Regulatory Attributes module, go to Regulatory Attributes Control (1.22.24).

See *User Guide: QAD Master Data* for details on the Regulatory Attributes module.

*Modify Co/By-Product Receipts.* The default is Yes. This allows receipt of any item from a base process work order. Enter No to restrict receipts to either items defined as part of the structure of the base process or to valid substitute items defined in Item Substitution Maintenance (13.19).

## Calculating Costs and Lead Times

Co-product costs and lead times are calculated by the same programs that calculate regular costs. Figure 5.7 outlines some typical steps for calculating and allocating co-product costs and lead times. Each step is discussed in more detail in the sections that follow.

**Fig. 5.7**  
Typical Cost Calculation Workflow for Co-products

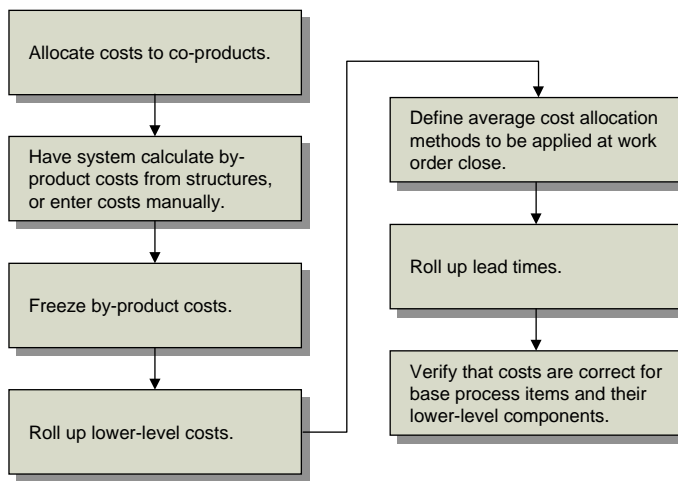

### Allocating Costs to Co-products

Assign cost allocation percentages in Process/Formula Maintenance (15.18) or Co/By-Product Maintenance (15.12.1).

The same co-product can result from more than one base process, but only one base process determines a co-product's cost at a particular site. That is, a co-product receives costs only from the base process specified in the BOM/Formula field of the co-product's item record.

See “Setting Up a Co/By-product Structure” on page 45.

**Example** Base Process A produces three co-products—pitted prunes, prune juice, and prune purée used to make Danish pastry. It also produces one by-product, pits. The net cost calculation for Base Process A is as follows.

Gross Cost (Base Process A)	\$105
By-product Costs	5
Net Cost (Base Process A)	\$100

Although prune juice is a significant co-product of Base Process A, it is also a co-product of Base Process B and, as defined in the BOM/Formula field of Item Master Maintenance (1.4.1), takes its costs from Base Process B. For Base Process A, cost allocation percentages are:

Co-product 1 (Pitted Prunes)	80%
Co-product 2 (Prune Juice)	0%
Co-product 3 (Prune Purée)	20%

Final allocated costs are:

Co-product 1 (Pitted Prunes)	$\$100 * 80\% = \$80$
Co-product 2 (Prune Juice)	$\$100 * 0\% = \$0$
Co-product 3 (Prune Purée)	$\$100 * 20\% = \$20$

By-product costs are calculated the same way as regular costs. That is, they are determined separately from the base process cost roll-up.

Once by-product costs are established, freeze them to ensure they are not changed during cost roll-up. Changing by-product costs after net base process costs have been calculated may result in unanticipated variances.

As in the previous example, the net cost for the base process should equal the sum of the costs allocated to the co-products. If these amounts are not equal, one or more of the following is likely:

- By-product costs were not frozen once subtracted from the base process gross cost. The system recalculated the by-product costs, changing the value of the base process net cost.
- Cost allocation percentages did not add up to 100%.
- Costs were allocated to a co-product whose cost was determined from a different base process than the one being rolled up. This can happen when a co-product is in the product structure of more than one base process.

If co-product costs do not add up to the base process net cost when work orders are closed, method change variances result.

The cost calculations related to base processes, by-products, and co-products are shown in the equations below.

Batch size	*	Base proc. unit cost	=	Base proc. batch cost
Batch size	*	By-prod. unit cost	=	By-prod. batch cost
Base proc. batch cost	-	By-prod. batch cost	=	Net base proc. batch cost
Net base proc. batch cost	*	Allocation %	=	Co-prod. batch cost
Co-prod. batch cost	÷	Quantity per batch	=	Co-prod. unit cost

## Entering By-product Costs

By-product costs are calculated separately from the base process cost roll-up. You can enter by-product costs manually or have the system calculate them from regular product structures or formulas.

Since by-product costs are to be deducted from base process gross cost on an element-by-element basis, there must be sufficient cost in each cost element of the base process to cover the amounts established in corresponding cost elements of the by-product.

If by-product costs are to be entered manually, use Item Master Maintenance (1.4.1), Item Cost Maintenance (1.4.9), or Item-Site Cost Maintenance (1.4.18). Enter costs for by-products of a base process using the same cost elements as the base process item.

**Note** As an alternative to entering by-product costs manually, roll up by-product costs from normal product structures using Routing Cost Roll-Up (14.13.13)

## Freezing By-product Costs

Freeze by-product costs using Roll-Up Freeze/Unfreeze (13.12.1).

*Site.* Enter the site to which these by-product costs apply.

*Cost Set.* Enter the cost set to be frozen.

*Item Number.* Enter item numbers for all by-products whose costs are to be frozen.

*Freeze/Unfreeze.* Enter Freeze.

## Rolling Up Costs

Roll up lower-level costs using Product Structure Cost Roll-Up (13.12.13) or Simulation Structure Cost Roll-Up (30.13.19). Keep in mind that the BOM/Formula code associated in the item master determines the base process for a co-product.

**Note** During roll-up, the system calculates and updates base process item costs using the unit of measure (UM) of the BOM/Formula code for the base process. This UM must be the same as the item UM for the base process.

*Item Number/To.* Typically, this program is run for all items. The system only updates base process item costs when roll-up selection criteria include all items in the co/by-product structure.

*Site.* Enter the site to which these costs apply.

*Cost Set.* Enter the cost set to which these costs apply. This is normally the GL or current cost set at the selected site.

Choose Next to begin roll-up and Back when roll-up is complete. To see the results of the roll-up, use Co/By-Products Cost Report (13.12.7).

## Calculating Average Costs for Co-products

Cost averaging for co-products happens when you close a work order using the following programs:

- Work Order Receipt (16.11)
- Work Order Receipt Backflush (16.12)
- Work Order Accounting Close (16.21)

When you run Work Order Accounting Close, the following occurs:

- Co-product costs are re-averaged by taking any remaining positive or negative WIP costs and allocating them to the co-products. If additional costs are recorded for a work order after costs are allocated, the remaining costs can be reallocated by reopening the closed work order, applying the transaction, and closing it again.
- General ledger (GL) and current costs are updated.

Some typical steps for calculating average GL costs and average current costs for co-products follow:

- 1 Define the average cost allocation methods in Average Cost Method Maintenance (15.12.5).
- 2 Verify that the following are correct:
  - Co-product/by-product definitions
  - Prices for co-products, if allocation method involves price
  - By-product costs
  - Base process batch size
  - UM of the BOM/Formula code for the base process equals the item UM for the base process
  - Site setup for cost sets (GL Cost Set and Current Cost Set)
  - Unit of measure conversions from base process to co-products and by-products

### Defining the Average Cost Allocation Methods

Define the average cost allocation methods using Average Cost Method Maintenance (15.12.5). The system provides three methods for allocating costs from a joint order set to co-products:

- Price
- Receipt Quantity
- Receipt Quantity and Price

If other methods are needed, users can provide their own programs. If no method is specified for a site, the Receipt Quantity method is used.

Allocation of base process costs to co-products is based on the cost of a standard batch size. All allocation percentages are calculated using equivalent units of measure based on the unit of measure for the base process. Where co-product units of measure differ from the unit of measure for the base process, the system employs conversion factors in order to express all costs in the base process unit of measure.

### Allocation by Price

The percentage of cost to allocate to a co-product is determined by its price, relative to the prices for the other co-products from a base process. Table 5.1 shows how costs are allocated by price.

**Table 5.1**  
Co-product Costs Allocated by Price

Item	UM	Conv	Price	Price (KG)	Price Based Allocation
P1	KG	1.00	2.00	2.00	25%
P2	KG	1.00	4.00	4.00	50%
P3	LT	0.50	1.00	2.00	25%

### Allocation by Receipt Quantity

The percentage of cost allocated to a co-product is determined by the total quantity produced (plus reject) for the co-product, relative to the receipt (plus reject) quantities for other co-products of the base process. Table 5.2 shows how costs are allocated by receipt quantity.

**Table 5.2**  
Co-product Costs Allocated by Receipt Quantity

Item	UM	Conv	Receipt Qty	Receipt Qty (KG)	Receipt Based Allocation
P1	KG	1.00	50.00	50.00	50%
P2	KG	1.00	30.00	30.00	30%
P3	LT	0.50	40.00	20.00	20%

### Allocation by Receipt Quantity and Price

The percentage of cost allocated to a co-product is determined by the extended price of the total quantity received plus reject for that co-product, relative to the prices and receipt plus reject quantities for the other co-products from a base process. All quantities are converted to the base process unit of measure.

Table 5.3 shows how costs are allocated by receipt quantity and price.

**Table 5.3**  
Co-product Costs Allocated by Price and Receipt Quantity

Item	UM	Conv	Rcpt Qty	Rcpt Qty (KG)	Price	Price (KG)	Price Qty	Price/Rcpt Allocation
P1	KG	1.00	50.00	50.00	2.00	2.00	100	38.48%
P2	KG	1.00	30.00	30.00	4.00	4.00	120	48.15%
P3	LT	0.50	40.00	20.00	1.00	2.00	40	15.38%

### Average Cost Accounting

WIP costs are the sum of component costs and shop floor control costs, and are reduced by the cost of co-products and by-products received plus reject quantity. These transactions do not update GL or current costs.

Costs are averaged by taking the costs accumulated in WIP and adjusting the costs of items in inventory received from WIP. The system does this in two steps:

- 1 Co-products and by-products are received from work orders into inventory using their current average costs.
- 2 Average GL costs and average current costs are re-averaged based on the costs accumulated for an item's work order when the work order is closed. Co-product costs are re-averaged based on any WIP costs accumulated by this process. Costs can be accumulated when the Work Order Accounting Close program closes any work order operations that have not been closed.

Costs are not re-averaged for quantities received to sites other than the work order (WIP) site. Receipts are handled in two ways depending on whether the work order status is closed or not closed:

- *Not closed.* Co-product costs are not re-averaged. Items are received to the work order WIP site using current average costs. These costs are deducted from WIP. If quantities are received at a different site, they are received at the work order WIP site using current average costs, then transferred to the indicated site.
- *Closed.* Co-product costs are re-averaged. Items are received to the work order WIP site using current average costs. These costs are deducted from WIP. The re-averaging process takes into account quantities received during previous receipt transactions for the same work order.

If quantities are received to a different site than the work order WIP site, it is likely that the inventory quantity on hand is less than the quantity received. This increases the chance that some of the costs cannot be allocated and re-averaged at the WIP site and that costs will be booked to the Inventory Discrepancy account for the base process.

To maximize the accuracy of average costs and reduce costs booked to discrepancy accounts, the following should be emphasized:

- Complete reporting of co-product and by-product quantities when all quantities for all items are completed.
- Setting of work order status to Closed when receipt quantities are reported.
- Running of Work Order Accounting Close on a regular basis to process recently closed work orders.

**Note** Re-averaging of co-product costs is time-sensitive. The greater the time between receipt and close, the greater the probability that some of the products produced have been consumed.

The cost change taken to inventory is bounded as follows:

- *Upper limit.* Greater of the existing average cost or calculated work order unit cost.
- *Lower limit.* Lesser of the existing average cost or calculated work order unit cost.

## Rolling Up Lead Times

The lead time to produce the co-products resulting from a base process is the same as the lead time for the base process. Cumulative Lead Time Roll-Up (13.12.14) copies the manufacturing lead time and the cumulative lead time for a base process to its co-products. Typically, the roll-up program is run for all items, not just those involved in co-product/by-product structures.

By-product lead times are not derived from the base process, but from roll-ups of regular product structures and routings. Enter by-product lead times in Item Planning Maintenance (1.4.7) or Item-Site Planning Maintenance (1.4.17).

## Reviewing Product Costs

To verify that costs are correct for base process items and their lower-level components, review costs using one of the following:

- Product Structure Cost Report (13.12.4). This report identifies an item as a co-product or a base process.

- Co/By-Products Cost Report (13.12.7). This report shows you how co-product costs were calculated from a base process and its by-products.

## MRP for Co-products/By-products

Because planned orders for co-products and by-products can be from more than one base process, overplanning of some items can result. This is because MRP plans each base process individually, based on unsatisfied demand for its co-products, rather than evaluating multiple base processes and delivering an optimum plan. Careful planning and setup of these operations by the manufacturer is therefore essential.

### Planning for By-products

MRP plans orders for a by-product as a result of creating planned orders for a base process. By-product demand is not considered when planning a base process, but unsatisfied demand for a by-product can result in a normal planned order if the item is purchased, distributed, or has a BOM/Formula code for a regular formula or product structure.

### Planning for Co-products

MRP creates base process demand records from the unsatisfied demand for a co-product. An item is a co-product if two conditions are met:

- It is manufactured—its Pur/Mfg code is Manufactured, Routable, or blank.
- Its BOM/Formula code is a base process that has the item as a co-product.

If these conditions are not met, the item is planned like a regular item.

MRP evaluates the beginning inventory, demand, supply, and safety stock for a co-product, and when there is unsatisfied demand, creates a demand record for its base process. This demand record reflects the amount of the base process required to meet the unsatisfied demand for the co-product.

As shown in Figure 5.8, MRP passes demand records directly from the co-product to the base process without using the co-product's order policy or related planning parameters.

**Fig. 5.8**  
MRP Processing of Co-products

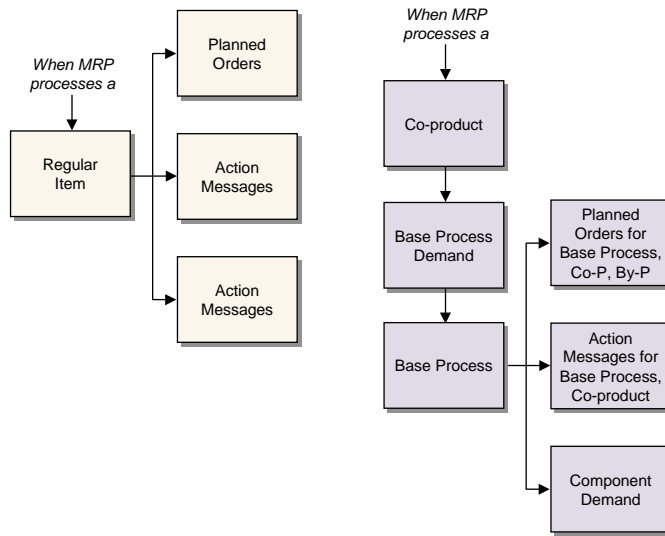

A co-product is like a parent of its base process. MRP plans all items in a site by low-level code, then by item number. Low-level codes are determined by parent/component relationships.

### Planning for Base Processes

MRP plans for a base process by determining the unsatisfied co-product demand for all co-products that reference the base process as their BOM/Formula code. MRP then creates planned orders to fill the unsatisfied co-product demand without regard to projected quantities on hand for the base process.

Unlike the planning process for regular items, MRP does not consider base process inventory. There should never be an on-hand balance for a base process. Use item status codes to prohibit inventory movements, sales, purchases, and repetitive orders on base process items.

See “Setting Up Item Status Codes for the Base Process” on page 44.

MRP does use the order policy and order modifiers for the base process, except safety stock, when creating planned orders. If the order policy is not period order quantity (POQ) or fixed order quantity (FOQ), MRP uses an order policy of POQ. If no order period is specified, MRP uses an order period of seven days.

When MRP plans a base process, it searches for the first unsatisfied demand record for a co-product. Then, depending on whether the order policy is POQ or FOQ, MRP evaluates unsatisfied demand records for all co-products of the base process:

*POQ.* MRP searches from the first unsatisfied demand record through the end of the order period.

*FOQ.* MRP looks at all unsatisfied demand records for all co-products that fall on the same date as the first unsatisfied demand record.

MRP creates one or more planned orders to satisfy demand for the co-product that presents the greatest demand for the base process for a specific date or date range. As a result, planned orders for the other co-products of the base process are also created.

## Reviewing, Updating, and Reporting Action Messages

MRP creates action messages for base processes and co-products, but not for by-products. Action Message Review/Update (23.5) and Action Message Report (23.7) allow reporting of action messages using various selection criteria, including BOM/Formula code. You can also exclude action messages for base process orders.

## Approving Planned Work Orders

To approve planned work orders, use Planned Work Order Approval (23.10). Specify base processes by entering a BOM/Formula code range. This program changes the status on all orders in a joint set from Planned to Firm. The joint set is not updated based on effectivity dates for the co-product/by-product structure (as is done when using Work Order Maintenance or Multiple Work Order Status Change), and work order detail is not re-created.

When a planned purchase order is approved, the system creates a regular firm planned work order, even if the item has a BOM/Formula code for a base process. If an MRP-planned order is originally purchased, MRP does not create a joint order set when it is approved as a work order.

## Creating Planned Order Reports

To create planned order reports, use Planned Order Report (23.12). To support features related to base processes, you can:

- Select planned orders by BOM/Formula code
- Include/exclude base process planned orders
- Include/exclude by-product planned orders
- Sort the report output by item number or BOM/Formula code

## Creating MRP Summary Reports

To create MRP summary reports, use MRP Summary Report (23.14). To support features related to base processes, you can:

- Select planned orders by BOM/Formula code
- Include/exclude base process planned orders
- Sort the report output by item number or BOM/Formula code

## Identifying the Source of Demand for a Co-product

To get detailed MRP information for co-products, by-products, and base processes, use MRP Detail Report (23.17). This feature provides pegging, which enables you to identify the source of demand for co-products. Indicate co-products by item number. You can also:

- Select planned orders by BOM/Formula code
- Include/exclude base process orders
- Sort the report by item number or BOM/Formula code within site

## Managing Joint Work Order Sets

Figure 5.9 outlines some typical steps for managing joint work order sets.

**Fig. 5.9**  
Typical Workflow for Joint Work Order Sets

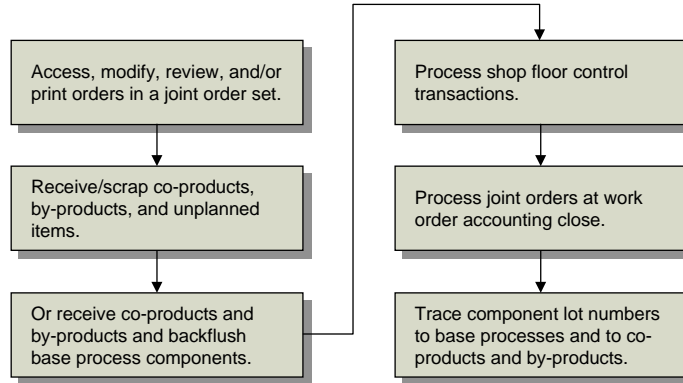

### Joint Work Order Sets

When you enter a work order for a base process or co-product, the system creates a *joint order set* comprised of a work order for the base process and one for each of its co-products and by-products. All work orders in the joint set (called *joint orders*) share the same work order number, site, and status, but have different work order IDs.

**Note** While Rework and Expense work orders may retain the work order number shared by the joint order set, they have a different status and are not considered part of the joint order set.

A joint order set consists of the following:

- A work order for the base process
- A work order for each co-product and by-product
- A work order bill for the base process
- A work order routing for the base process

### Accessing and Modifying Joint Order Sets

Joint orders for co-products and by-products can be added or deleted from a joint set when the status of the set is Exploded, Allocated, or Released. Status codes determine when and how joint work orders can be modified relative to each other. Status codes are always the same for all orders in a joint set. The processing and restrictions applied are similar to those applied to work order bills.

Table 5.4 describes how work order status codes affect joint work orders.

**Table 5.4**  
Effect of Work Order Status Codes

Code	Status	Description
P	Planned	MRP creates an imploded joint order set reflecting the base product structure as of the order release date.
B	Batch	An order is created for a single co-product or base process item. Orders are not imploded.
F	Firm	Orders are imploded to reflect the base product structure as of the order release date. You can modify co-product/by-product quantities and the base process quantity. All quantities are automatically rescaled. When an MRP-planned order in a joint order set is approved, all joint orders in the set are changed to status Firm.
E	Exploded	The same as Firm, except you can modify quantities for co-product or by-product orders without automatically rescaling other orders. You can add or delete orders from a joint order set. Delete is not allowed if quantities or costs have been received for an item on that order.
A	Allocated	Same as exploded.
R	Released	Same as exploded.
C	Closed	When the status of a joint order set is changed to Closed, and average cost method is used, updates are made to current AVG, current LAST, and GL average costs.

Joint order sets can be created for regular work orders (where Type is blank), but not for work order types such as Expense, Rework, Scheduled, Cumulative, and Final Assembly. Joint orders can be added to or deleted from a joint set when the status is Exploded, Allocated, or Released.

**Note** A joint order set must have only one base process order and at least one co-product order. If you delete the base process order or the only co-product order, the entire set is deleted.

To access and modify a joint order set, use Work Order Maintenance (16.1).

*Item Number.* Enter the item number for a base process or a co-product.

*Type.* Leave blank.

*Routing Code.* Optionally, enter an alternate routing code set up for the base process in Alternate Routing Maintenance (14.15.1).

*BOM/Formula.* Optionally, enter an alternate base process item number. To enter this field, the work order must be for a co-product, *and* the base process must be set up as an alternate product structure in Alternate Structure Maintenance (13.15).

*Adjust Co/By Order Quantities.* Enter Yes or No. This field does not appear on base process work orders.

If the order quantity changes, entering Yes automatically rescales all order quantities in the joint order set. The work order status must be E, A, R, or C to optionally rescale quantities. Joint order quantities are recalculated automatically when:

- Order quantity changes on a joint order whose status is Firm.
- Status of a work order changes from any status to Firm.

- Status of a work order changes from Batch, Planned, or Firm, to Exploded, Allocated, or Released.

The system calculates the quantities for joint orders from quantities entered in Co/By-Product Maintenance (15.12.1). Order quantities for a joint order set can be recalculated automatically or maintained manually, depending on the work order status.

*Adjust Co/By Order Dates.* Enter Yes or No. This prompt does not appear on base process work orders. If the order, release, or due date changes, entering Yes resynchronizes the dates for all orders in the joint order set. The work order status must be E, A, R, or C to optionally adjust dates. Firm status orders always resynchronize the dates for all orders in the set.

Default due dates for orders in a joint set are calculated using the manufacturing lead time for the base process.

*Mix Variance Acct, Sub-Account, and Cost Center.* Enter the account number for Mix Variance. Account defaults from the product line of the item and may be different for work orders within a joint order set. If this field is blank, you should define a default account in Product Line Maintenance (1.2.1). See “Setting Up Mix Variance Accounts” on page 43.

## Creating a Joint Order Set from an Alternate Base Process

To create a joint order set using an alternate base process, use Work Order Maintenance (16.1).

- Enter a work order using the item number for the alternate base process.
- Enter a work order for a co-product and specify an alternate base process as its BOM/Formula code. Define valid alternate base processes using Alternate Structure Maintenance (13.15). Enter the co-product item as the item number and the base process as the BOM/Formula.

## Reviewing, Printing, and Releasing Joint Orders

To review joint work orders, use Joint Work Order Inquiry (16.3.13). Orders can be specified by item number, work order number, work order ID, BOM/Formula code, due date, site, or any combination of these.

To print a joint order set, use Work Order Release/Print (16.6) or Multiple Work Order Release/Print (16.7). Both programs release the joint order set, provided one order in the set is selected for processing. In addition to standard work order picklists and routings, you can also print documents listing the co-products and by-products expected for a base process. You can print the list of co-products and by-products before the picklist or after the routing operations.

- When a joint order’s status changes to Released and the associated base process has a component that is routable (the Pur/Mfg Code for the component item is R), a routable work order is automatically created. When created, the routable work order’s status is Batch.  
Routable work orders created from a joint order set use the joint set work order number, but are given a unique suffix. For example, a joint order set with work order number 1234 can create routable work orders 1234-1 and 1234-2.
- When a routable work order is created from a regular work order, the routable work order uses the work order number of the parent, but has a unique work order ID.

To select closed work orders and print summary data on each, use Work Order History Report (16.3.6). You have the option to print bill of material detail or routing detail. To print joint order sets, set Print Co/By-Product Orders to Yes. If Yes, the report displays information for each of the co-product and by-product orders for a base process work order.

To print information for each order related to a base process work order, use Work Order WIP Cost Report (16.3.5). To print information on items received and scrapped from a joint order set, use Work Order Cost Report (16.3.4). These reports show the costs for joint order sets once they have been closed in Work Order Accounting Close (16.21).

## Receiving, Scrapping, and Backflushing

To receive and scrap co-product and by-products in a joint order set, use Work Order Receipt (16.11), Work Order Receipt Backflush (16.12), or Work Order Operation Backflush (16.19). You can initiate these programs using any work order in a joint order set.

In Work Order Receipt (16.11):

*Work Order.* Enter any work order number in the joint order set.

*ID.* Enter the specific ID desired, or leave blank to retrieve the first ID in the joint order set.

*Receive All Co/By-Products.* Enter Yes if all co-products and by-products are to be received. Enter No if only this particular order is to be received. This prompt only applies if the order being received is not for the base process. When the base process order is received, all related work orders are received by default.

Use Work Order Receipt Backflush (16.12) and Work Order Operation Backflush (16.19) to:

- Modify the backflush quantity and method.
- Initiate transactions to receive co-products and by-products.
- Backflush (issue) base process components. When components are backflushed, the receipt and scrapped quantities are used to calculate default issue quantities for the components.

## Backflush Calculation Methods

Specify one of two backflush methods for the base process in Co/By-Product Maintenance (15.12.1) or Process/Formula Maintenance (15.18). The backflush quantity for the base process is used to calculate backflush (issue) quantities for the components of a joint order set.

In Work Order Receipt Backflush (16.12):

*Work Order.* Enter any work order number in the joint order set.

*ID.* Enter the specific ID desired, or leave blank to retrieve the first ID in the joint order set.

*Receive All Co/By-Products.* Enter Yes if all co-products and by-products are to be received. Enter No if only the items on this particular order are to be received.

*Backflush Method.* Enter 1 or 2. Method 1 backflushes based on the co-product and by-product quantities received. Method 2 backflushes based on the order quantity of the base process. The following two sections describe each method in more detail.

### Backflush Method 1

The backflush (base process) quantity is calculated from the receipt quantities processed for all the co-products and by-products. Unit of measure conversion factors are used to express all item quantities in base process units.

Use Method 1 when the quantity for a batch is directly related to the sum of its output. For example, for a process that sorts fruit into different sizes and grades, the batch quantity can be calculated from the total amount of fruit processed for all sizes and grades. This method is generally used when there is greater variability in output percentages for products.

### Backflush Method 2

The default backflush (base process) quantity is the order quantity for the base process work order. You can change the backflush quantity to reflect the actual quantity processed for a batch.

Use Method 2 when the batch quantity is closely related to the expected output of a particular co-product. For example, for a process that makes ice cream, the batch quantity can be calculated from the amount of ice cream processed. Any by-products, such as waste water, are not necessary for the calculation of the batch quantity.

## Receiving Unexpected Items

Occasionally, an item produced from a joint order has a different grade or quality than expected. When this is the case, and the item assumes a different item number than the expected item, it can be received even without a joint order in the set for the unexpected item. These items are received as substitutes. A new order with a quantity of zero is added to the joint set.

Regulatory Attributes Control (1.22.24) setting for Modify Co/By-Product Receipts determines what items can be received by:

- Work Order Receipt (16.11)
- Work Order Receipt Backflush (16.12)
- Work Order Operation Backflush (16.19)

When an item does not have a joint order in the joint order set being processed:

- Yes enables a receipt to be processed for any item number, even if it is not defined as a co-product or by-product of the base process.
- No enables you to receive only the expected items or valid substitute items. Valid substitute items are defined in Item Substitution Maintenance (13.19).

When a substitute item is received instead of an expected one, change the status of the joint set to Closed shortly after recording the receipt. The order and open quantities for the expected item remain unchanged when another item is received as an unplanned receipt. Closing the joint order set effectively changes the open or expected quantities for all items to zero.

See “Setting Up Definitions for Valid Substitute Items” on page 49.

## Receiving Unplanned Items

Use Unplanned Receipts (3.9) to receive an item that has no work order. Related items in the co-product/by-product structure cannot be received with the item.

## Processing Shop Floor Control Transactions

Shop floor control transactions are processed using the base process order for a joint order set.

## Processing Joint Orders at Work Order Close

Use Work Order Accounting Close (16.21) to process joint orders when a base process order is selected to be closed. This procedure calculates mix variances, updates current average and last costs, and updates GL average costs for co-products and by-products.

## Deleting and Archiving Joint Orders

Use Work Order Delete/Archive (16.23) to process all orders in a joint set when any one of the work orders in the set is selected for processing.

## Tracing Lots

The lot number for a base process is its work order ID number or the lot number assigned to that order using Work Order Attribute Maintenance (1.22.4). The system automatically maintains lot-to-lot relationships for joint orders by creating receipt and issue transactions between a base process and its joint order set. These are memo transactions that do not update inventory or create GL transactions.

- Use Lot Where-Used Inquiry (3.22.4) to trace a component lot number to a base process and trace upward from the base process to the co-product and by-product lots produced from it.
- Use Lot Actual Bill Inquiry (3.22.3) to trace a co-product or by-product lot number to the base process that produced it and trace downward to the component lots for the base process.

## Accounting for Joint Orders

All GL transactions for issues, receipts, and shop floor control transactions update the WIP account for the base process work order. Table 5.5 shows the origins of account, sub-account, and cost center information for work order transactions.

**Table 5.5**  
Origins of Account, Sub-Account, and Cost Center Information

Account/Sub-Account/Cost Center	Base Process	Co-product By-product	Component
Inventory		Product Line	Product Line
Scrap		Product Line	
WIP	Work Order		
Material Usage Variance	Work Order		
Material Rate Variance	Work Order		
Subcontract Usage Variance	Work Order		
Mix Variance		Work Order	
Floor Stock	Work Order		

## Calculating Mix Variances for Joint Orders

Mix, or yield, variance is the costed difference between the actual quantities received and scrapped for a co-product or by-product and the expected receipt quantity for that product.

For a co-product or by-product, the expected receipt quantity is not always the same as the quantity planned when the joint order set was created. For example, you may receive more or fewer co-product or by-product items than ordered because you issued fewer components than originally planned. In this case, you will probably want the system to consider actual product receipt quantities as part of the mix variance calculation.

Mix variance calculation methods for co-products and by-products can accommodate a wide range of base process types and receipt scenarios.

To determine the mix variance amount for a co-product or by-product work order, the system first calculates the expected receipt quantity for the order by multiplying the following two factors:

- The ratio between the co-product or by-product quantity ordered and the base process quantity ordered, expressed as a decimal value
- The base process quantity complete, which is variable and calculated based on the quantity complete method specified in the co/by-product structure

Also see “Setting Up Mix Variance Accounts” on page 43.

The base process quantity complete can be based on any one of the following, depending on the setting of Quantity Complete Method in Process/Formula Maintenance (15.18) or Co/By-Product Maintenance (15.12.1):

- The total quantity complete for all co-products and by-products in the joint order set (SUM)
- The total quantity complete for co-products only (SUMC)
- The base process quantity required to complete the co-product that consumed the greatest amount of the base process in proportion to the quantity ordered (MAX)
- The base process quantity required to complete the co-product that consumed the least amount of the base process in proportion to the quantity ordered (MIN)
- The quantity ordered on the base process order (ORD)

See “Setting Up a Co/By-product Structure” on page 45.

**Note** When method SUM or SUMC is used, the system converts co-product or by-product quantities to the base process unit of measure before adding them together.

The following equation is used to calculate the expected receipt quantity for a co-product or by-product:

$$\text{Expected Receipt Quantity} = \text{Base Process Quantity Complete} * (\text{Co-product or By-product Qty Ordered} / \text{Base Process Quantity Ordered})$$

To calculate the mix variance amount for a co-product or by-product work order, the system compares the actual work order receipt quantity with what the system expected to receive based on the base process quantity complete. The equation used to calculate mix variance is as follows:

$$\text{Mix Variance} = (\text{Expected Receipt Quantity} - \text{Co/By-product Actual Receipt Qty}) * \text{Co/By-product Unit Cost}$$

The base process quantity complete, as determined by the quantity complete method, is also used in place of the work order quantity when calculating material and labor usage variances for a base process work order.

For more information on work order variances, see “Work Order Accounting Close” on page 101.

The following examples illustrate how the setting of Quantity Complete Method on the co/by-product structure determines how mix variances are calculated for co-products and by-product work orders. Each example uses the sample co/by-product structure shown in Figure 5.10.

**Fig. 5.10**  
Sample Co/By-product Structure

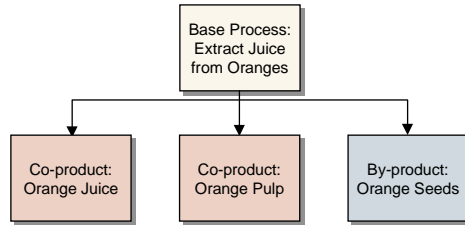

The sample base process has only one component: oranges. Base process work orders have a batch quantity of 100 base-process units and the expected yield quantities per batch (order quantities) shown in Table 5.6.

**Table 5.6**  
Sample Co-product and By-product Order Quantities

Co/By-product	Order Quantity
Orange Juice (Co-product)	50 liters
Pulp (Co-product)	30 kg
Seeds (By-product)	10 kg

The base process unit of measure (UM) is KG (kilograms). For the first co-product, orange juice, the conversion factor between the base process and co-product units of measure is 1.2 liters (LT) per 1.0 KG.

Co-product and by-product costs are shown in Table 5.7.

**Table 5.7**  
Sample Co-product and By-product Costs

Co/By-product	Standard Cost
Orange Juice	\$1.50 per LT
Pulp	\$0.50 per KG
Seeds	\$0.60 per KG

For a given joint order set, actual co-product and by-product yields are as shown in Table 5.8.

**Table 5.8**  
Sample Co-product and By-product Yields

Order ID	Product	Qty Complete	Qty Rejected
1001	Orange Juice	55 liters	1 liter
1002	Pulp	25 kg	3 kg
1003	Seeds	15 kg	0 kg

**Note** Although a single example is used to illustrate all five quantity complete methods, some methods may be more appropriate to particular process environments than others.

To display numeric values in the following examples, these conventions are used:

- Currency amounts are rounded to the nearest hundredth.
- Non-currency decimal values are rounded to the nearest ten-thousandth.

### Summarize

If Quantity Complete Method is set to SUM in the co/by-product structure, the following equation is used to determine the base process quantity complete:

$$\text{Base Process Quantity Complete} = [(\text{Co-prod1 Quantity Complete} + \text{Scrap}) * \text{Base Process UM Conversion Factor}] + (\text{Co-prod2 Quantity Complete} + \text{Scrap}) + (\text{By-prod1 Quantity Complete} + \text{Scrap})$$

$$\text{Base Process Quantity Complete} = [(55 + 1) * 1.2] + (25 + 3) + (15 + 0) = (56 * 1.2) + 28 + 15 = 67.2 + 28 + 15 = 110.2$$

In this case, expected co-product and by-product order receipt quantities are calculated as shown in Table 5.9.

**Table 5.9**  
Sample Expected Receipt Calculations for SUM Method

Order ID	Product	Expected Receipt Calculation
1001	Orange Juice	$110.2 * (50 / 100) = 110.2 * 0.5 = 55.1$
1002	Pulp	$110.2 * (30 / 100) = 110.2 * 0.3 = 33.06$
1003	Seeds	$110.2 * (10 / 100) = 110.2 * 0.1 = 11.02$

Based on these expected quantities, mix variance calculations are as shown in Table 5.10.

**Table 5.10**  
Sample Mix Variance Calculations for SUM Method

Order ID	Product	Mix Variance Calculation
1001	Orange Juice	$(55.1 - 56) * \$1.50 = 0.9 * \$1.50 = -\$1.35$
1002	Pulp	$(33.06 - 28) * \$0.50 = 5.06 * \$0.50 = \$2.53$
1003	Seeds	$(11.02 - 15) * \$0.60 = -3.98 * \$0.60 = -\$2.39$

The Summarize method may be appropriate for base processes in which the sum of the co-product and by-product output quantities is always close to or equal to the base process quantity. Examples of this type of base process include processes that involve sorting and separation of co-products and by-products, such as a process that sorts fruit by size and weight.

### Summarize Co-products

If Quantity Complete Method is set to SUMC in the co/by-product structure, the following equation is used to determine base process quantity complete:

$$\text{Base Process Quantity Complete} = [(\text{Co-prod1 Quantity Complete} + \text{Scrap}) * \text{Base Process UM Conversion Factor}] + (\text{Co-prod2 Quantity Complete} + \text{Scrap})$$

$$\text{Base Process Quantity Complete} = [(55 + 1) * 1.2] + (25 + 3) = (56 * 1.2) + 28 = 67.2 + 28 = 95.2$$

In this case, expected co-product and by-product order receipt quantities are calculated as shown in Table 5.11.

**Table 5.11**  
Sample Expected Receipt Calculations for SUMC Method

Order ID	Product	Expected Receipt Calculation
1001	Orange Juice	$95.2 * (50 / 100) = 95.2 * 0.5 = 47.6$
1002	Pulp	$95.2 * (30 / 100) = 95.2 * 0.3 = 28.56$
1003	Seeds	$95.2 * (10 / 100) = 95.2 * 0.1 = 9.52$

Based on these expected quantities, mix variance calculations are as shown in Table 5.12.

**Table 5.12**  
Sample Mix Variance Calculations for SUMC Method

Order ID	Product	Mix Variance Calculation
1001	Orange Juice	$(47.6 - 56) * \$1.50 = -8.4 * \$1.50 = -\$12.60$
1002	Pulp	$(28.56 - 28) * \$0.50 = 0.56 * \$0.50 = \$0.28$
1003	Seeds	$(9.52 - 15) * \$0.60 = -5.48 * \$0.60 = -\$3.29$

Because it does not consider by-product quantities, the Summarize Co-products method may be appropriate in environments where completed by-products cannot always be traced to particular base process orders. For example, in some business environments, completed by-product quantities are reported in bulk at the end of each shift instead of in conjunction with work order operations.

#### Maximum

If Quantity Complete Method is set to MAX in the co/by-product structure, the system considers the quantity complete for each co-product and determines the quantity of the base process typically required to generate that co-product quantity.

The following calculation is performed for each co-product with a nonzero order quantity:

$$(Co-product\ Quantity\ Complete + Scrap) * (Base\ Process\ Quantity\ Ordered / Co-product\ Quantity\ Ordered)$$

The co-product that yields the highest result determines the base process quantity complete for the joint order set.

For the sample joint order set, calculations are as follows:

$$Co-prod1\ Quantity = (55 + 1) * (100 / 50) = 56 * 2 = 112$$

$$Co-prod2\ Quantity = (25 + 3) * (100 / 30) = 28 * 3.3333 = 93.3324$$

Since the calculation for co-product 1 (orange juice) yields the highest result, 112 is used as the base process quantity complete for the joint order set.

Expected co-product and by-product receipt quantities are calculated as shown in Table 5.13.

**Table 5.13**  
Sample Expected Receipt Calculations for MAX Method

Order ID	Product	Expected Receipt Calculation
1001	Orange Juice	$112 * (50 / 100) = 112 * 0.5 = 56$
1002	Pulp	$112 * (30 / 100) = 112 * 0.3 = 33.6$
1003	Seeds	$112 * (10 / 100) = 112 * 0.1 = 11.2$

Based on these expected quantities, mix variance calculations are as shown in Table 5.14.

**Table 5.14**  
Sample Mix Variance Calculations for MAX Method

Order ID	Product	Mix Variance Calculation
1001	Orange Juice	$(56 - 56) * \$1.50 = 0 * \$1.50 = \$0.00$
1002	Pulp	$(33.6 - 28) * \$0.50 = 5.6 * \$0.50 = \$2.80$
1003	Seeds	$(11.2 - 15) * \$0.60 = -3.8 * \$0.60 = -\$2.28$

When the Maximum method is used, the co-product that consumed the largest quantity of the base process in proportion to the quantity ordered always has a zero mix variance. This is because the base process quantity complete is derived directly from the actual quantity complete for that co-product.

The Maximum and Minimum methods are most appropriate when a particular co-product in the co/by-product structure is considered the primary co-product for the base process. A primary co-product typically drives demand and determines the rate of production for the base process. Examples of production processes that involve a primary co-product include sheet-metal stamping and injection molding.

#### Minimum

If Quantity Complete Method is set to MIN in the co/by-product structure, the system performs the same calculations for each co-product in the joint order set as when Quantity Complete Method is MAX. However, the calculation that yields the lowest rather than the highest result is used to determine the base process quantity complete.

For the sample joint order set, calculations are as follows:

$$\text{Co-prod1 Quantity} = (55 + 1) * (100 / 50) = 56 * 2 = 112$$

$$\text{Co-prod2 Quantity} = (25 + 3) * (100 / 30) = 28 * 3.3333 = 93.3324$$

Since the calculation for co-product 2 (pulp) yields the lowest result, 93.3324 is used as the base process quantity complete for the joint order set.

Expected co-product and by-product receipt quantities are calculated as shown in Table 5.15.

**Table 5.15**  
Sample Expected Receipt Calculations for MIN Method

Order ID	Product	Expected Receipt Calculation
1001	Orange Juice	$93.3324 * (50 / 100) = 93.3324 * 0.5 = 46.6662$
1002	Pulp	$93.3324 * (30 / 100) = 93.3324 * 0.3 = 27.9997$
1003	Seeds	$93.3324 * (10 / 100) = 93.3324 * 0.1 = 9.3332$

Based on these expected quantities, mix variance calculations are as shown in Table 5.16.

**Table 5.16**  
Sample Mix Variance Calculations for MIN Method

Order ID	Product	Mix Variance Calculation
1001	Orange Juice	$(46.6662 - 56) * \$1.50 = -9.3338 * \$1.50 = -\$14.00$
1002	Pulp	$(27.9997 - 28) * \$0.50 = 0.0003 * \$0.50 = \$0.00$
1003	Seeds	$(9.3332 - 15) * \$0.60 = -5.6668 * \$0.60 = -\$3.40$

When the Minimum method is used, the co-product that consumed the smallest quantity of the base process in proportion to the quantity ordered always has a zero mix variance. This is because the base process quantity complete is derived directly from the actual quantity complete for that co-product.

For more information on when to use this method, see “Maximum” on page 68.

## Order

If the Quantity Complete Method for the co/by-product structure is ORD, the base process quantity complete is equal to the quantity ordered on the original base process work order (100).

In this case, expected co-product and by-product order receipt quantities are calculated as shown in Table 5.17.

**Table 5.17**  
Sample Expected Receipt Calculations for ORD Method

Order ID	Product	Expected Receipt Calculation
1001	Orange Juice	$100 * (50 / 100) = 100 * 0.5 = 50$
1002	Pulp	$100 * (30 / 100) = 100 * 0.3 = 30$
1003	Seeds	$100 * (10 / 100) = 100 * 0.1 = 10$

Based on these expected quantities, mix variance calculations are as shown in Table 5.18.

**Table 5.18**  
Sample Mix Variance Calculations for ORD Method

Order ID	Product	Mix Variance Calculation
1001	Orange Juice	$(60 - 56) * \$1.50 = 4 * \$1.50 = \$6.00$
1002	Pulp	$(30 - 28) * \$0.50 = 2 * \$0.50 = \$1.00$
1003	Seeds	$(10 - 15) * \$0.60 = -5 * \$0.60 = -\$3.00$

The Order method may be appropriate in environments where batch quantities for co-products and by-products are determined by some external factor such as the production equipment used and are, therefore, constant.

## Restrictions

### Inventory

*Receipts–Backward Exploded (3.12).* The inventory backflush program can be used to receive an item using a normal BOM/Formula code, but cannot be used to receive a base process item or process an item with a base process as its BOM/Formula code.

### Purchasing

*Purchase Order Maintenance (5.7).* A subcontract purchase order line (Type is Subcontract) cannot reference a work order that is a co-product, by-product, or base process work order.

*Purchase Order Receipts (5.13.1).* A joint work order cannot be referenced when processing a receipt of an item on a subcontract purchase order line.

*(Supplier) Schedule Update from MRP (5.5.3.1).* A supplier schedule cannot be updated with an MRP-planned order for a co-product or base process from a joint order set.

## Repetitive and Advanced Repetitive

The Repetitive and Advanced Repetitive modules do not support joint schedules like the Work Orders module supports joint order sets.

*Line Schedule Workbench (18.1.10, 18.22.1.10).* The line schedule (workbench) can be updated using normal MRP-planned orders for an item on a production line, but not using MRP-planned orders for a co-product or base process from a joint order set.

*Schedule Maintenance (18.2.1, 18.22.2.1) and Schedule Explosion (18.2.4, 18.22.2.4).*

A repetitive schedule can be entered for a co-product, but the schedule that is exploded from it does not include the other co-products and/or by-products for its base process.

Similarly, a repetitive schedule can be entered for a base process, but the schedule that is exploded from it does not include co-products or by-products.



# Work Orders

The Work Orders module enables you to manage manufacturing orders in discrete manufacturing environments.

## ***Introduction*** 75

Defines work orders and discusses work order life cycles, restrictions, and other features.

## ***Defining Control Settings*** 77

Describes using Work Order Maintenance and Master Schedule Order Maintenance as well as types of work order, work order status, routing codes, and BOMs/formulas.

## ***Creating Work Orders*** 78

Describes how work orders can be scheduled manually and how lead time calculations and operation schedules are generated.

## ***Scheduling Work Orders*** 85

Describes how work order schedules can be controlled manually, lead times can be calculated, and operations can be scheduled.

## ***Modifying Work Orders*** 88

Describes how to modify work order bills and routings.

## ***Releasing Work Orders*** 89

Outlines the circumstances under which a work order can be released, the effects of releasing an order, and how key items can be used to prevent an order from being released when there are component shortages.

## ***Splitting Work Orders*** 90

Describes why splitting orders is sometimes necessary and how splitting an order affects order IDs.

## ***Creating Picklists*** 90

Defines a picklist, outlines the basics of picklist logic, and describes printing and reprinting them.

## ***Issuing Components*** 91

Describes how to issue components to a work order, how to issue and receive items at sites other than the order site, and work with subcontractors to complete operations.

## ***Receiving Work Orders*** 94

Describes how to receive and backflush work orders and manage scrap.

## ***Generating Reports*** 99

Describes how to generate types of reports using the Repetitive module.

## ***Closing Work Orders*** 100

Describes how to close a work order using Work Order Maintenance or Work Order Accounting Close, as well as how to write procedures for period-sensitive closes and ledger ends.

***Deleting Work Orders*** 102

Describes the necessary conditions for deleting and/or archiving work orders using Work Order Maintenance, Work Order Accounting Close, and Work Order Delete/Archive.

## Introduction

A work order is an authorization to produce a specific quantity of an item for a specific date. A work order may represent a manufacturing production order, a repetitive schedule, or a sequenced production line.

Work orders are typically created in response to current or projected demand for an item. You can also use them to build up inventory in anticipation of future demand when there is unused manufacturing capacity.

## Work Order Life Cycle

Figure 6.1 illustrates a typical work order life cycle.

**Fig. 6.1**  
Work Order Life Cycle

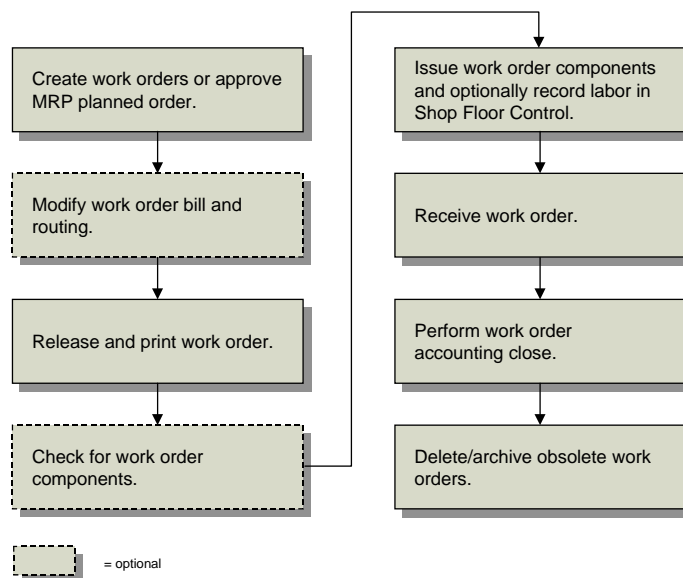

Work Order Operation Backflush (16.19) combines:

- The issuing functions of Work Order Component Issue (16.10)
- The labor reporting functions of Labor Feedback by Work Order (16.20.1)
- The receipt functions of Work Order Receipts (16.11)

If you use Work Order Operation Backflush, the typical workflow for work orders is simplified, since you can combine three separate steps into one.

Work orders are tightly integrated with other manufacturing modules:

- Define bills of material and product structures for work orders in the Product Structures module. See page 5.
- Define routings and operations for work orders in the Routings/Work Centers module. See page 17.
- Create planned orders to fill demand with Material Requirements Planning. See page 267.
- Schedule operations with Capacity Requirements Plan. See page 285.

- Monitor and report on the progress of a work order in the Shop Floor Control module. See page 103.

## Manufacturing Environments

Features that support different manufacturing environments are provided. The Work Orders and Shop Floor Control modules are typically used to manage job shop manufacturing. The Advanced Repetitive or Repetitive modules manage manufacturing in an assembly line environment. Table 6.1 compares and contrasts the two types of environments.

See Chapter 8 and Chapter 9 for details.

**Table 6.1**  
Manufacturing Environments

	<b>Work Orders</b>	<b>Repetitive</b>
<b>Plant Organization</b>	Variable by product	Fixed by assembly line
<b>Routing</b>	Functional departments	Fixed by line
<b>Material Handling</b>	Fork lifts, tote bins	Conveyors, containers
<b>Product Mix</b>	Many products	Similar products
<b>Amount of Work in Process</b>	High	Low
<b>Time to Manufacture</b>	Variable by product	Short
<b>Examples</b>	Tools, furniture	Auto assembly, tires

## Work Order by Site Control

When two or more manufacturing sites exist within one physical database, they are often managed by different production controllers or planners.

Many work order programs let users select a range of orders to process. When a database has multiple sites, it is important that planners update only the orders for which they are responsible. In most cases this means restricting order update to a single site.

Most work order update programs and reports include either a site selection or a site range selection. Site security, defined in the System Security menu (36.3) is checked for all programs that update the database. If the site selection is blank, the user must have access to all sites. Users with access to only specific sites must run the programs by limiting the site selection appropriately.

See *User Guide: QAD Security and Controls* for details.

## Restricted Transactions

In some cases, the work order release mechanism needs to be controlled for an item because engineering changes must be completed before the order can be released into the manufacturing process.

You can prevent such an item from inadvertently reaching the shop floor on a work order by setting up a status code in Item Status Code Maintenance (1.1.5) that is restricted for the ADD-WO transaction. Then enter that code in the Status field in Item Master Maintenance (1.4.1) or Item Data Maintenance (1.4.3).

In Work Order Maintenance (16.1), you cannot enter an order or change the work order status of an MRP planned order for an item with a restricted item status code. Additionally, the following programs display an error message if you attempt to release or update the status on a work order for such an item:

- Work Order Release/Print (16.6)
- Multiple WO Release/Print (16.7)
- Multiple WO Status Change (16.8)

## Effects of Optional Modules

Some features of work orders are affected if you are using the Regulatory Attributes module. When this module is active, you can assign batch numbers, restrict items issued to an order, restrict items received, and enforce stricter lot/serial control rules. These features are described in detail in the discussion of the Regulatory Attributes module. The description of work orders in this chapter assumes that Regulatory Attributes features are not active.

See *User Guide: QAD Master Data* for details on the Regulatory Attributes module.

The WIP Lot Trace module (WLT) affects some work order functions. When WIP Lot Trace is active, you can:

- Monitor and trace work in process (WIP) inventory.
- Track WIP material lot/serials processed by multiple subcontractors.
- Maintain detailed historical records, including which components produced a finished item and which finished items went to a customer.

WIP Lot Trace is available as option 3.22.13. When activated, additional frames display in some work order programs. The discussion in this chapter assumes that WLT features are not active.

See Chapter 10, “WIP Lot Trace,” on page 189.

## Defining Control Settings

Use two programs to specify control and default values for work order processing.

Work Order Control (16.24) includes several settings that mainly affect numbering and comment defaults. An additional field affects the work order release process.

**Fig. 6.2**  
Work Order Control (16.24)

The screenshot shows a software dialog box titled "Work Order Control". At the top, there is a title bar with a close button (X) and a menu bar containing "Go To" and "Actions". The main content area is a list of settings, each with a checkbox:

- Auto W/O Numbers:
- Next W/O Nbr:
- Work Order Comments:
- Routing Comments:
- Move First Operation:

**Move First Operation.** This field determines whether the work order release function sets the status of the first operation to Queue. If No, the operation status is left blank and must be changed manually.

This field is typically set to Yes. The released order then appears on the dispatch list for the specified work center and the Queue status indicates it is waiting to be started. If a lengthy picking effort is required, the work order may not be ready as soon as it is released. In this case, set this field to No. Use Operation Move to change the status later.

Work Order Accounting Control (36.9.11) includes two settings that impact the general ledger transactions created by work orders.

**Fig. 6.3**  
Work Order Accounting Control (36.9.11)

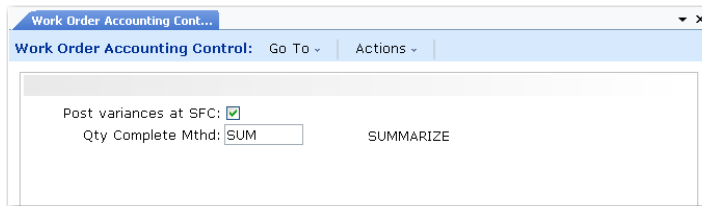

**Post variances at SFC.** This field sets the default for the same field in Work Order Maintenance.

**Yes:** Labor and burden variances are calculated and posted whenever shop floor labor feedback transactions are entered.

**No:** Variances are suppressed and not calculated or posted until the work order is received.

Setting this field to No reduces the number of variance transactions posted to the general ledger, particularly if there are many shop floor labor transactions processed before material receipts are recorded.

If you have very long run times, set this field to No, suppressing variance calculations until finished product is received. If you have short run times, set this field to Yes.

**Quantity Complete Method.** The value of this field defaults to Process/Formula Maintenance (15.18) and Co/By-Product Maintenance (15.12.1) and affects the calculation of mixed variances. See “Calculating Mix Variances for Joint Orders” on page 65.

## Creating Work Orders

Work orders are created directly using Work Order Maintenance (16.1). For convenience, you can also create them in Master Schedule Order Maintenance (22.13). The two programs are identical.

Work orders are also created as the result of executing other functions.

- Running MRP generates planned orders. Once approved in Planned Work Order Approval (23.10), these orders can be managed in the Work Orders module.
- Releasing a sales order or service return material authorization (RMA) for a configured item to a work order in Sales Order Release to Work Order (8.13).
- Releasing an RMA receipt line to a work order with RMA Release to Work Order (11.7.1.5).
- Releasing a parent work order for an item with a routable component creates a related work order for the component.

Some work orders are created and managed in other modules. These cannot be updated in Work Order Maintenance.

- Work orders created by entering repetitive schedules are managed in the repetitive module.

- Work orders created to handle customer service activities are managed with Call Activity Recording (11.1.1.13) in the Service/Support Management module and Project Activity Recording (10.5.13) in the Project Realization Management module. Customer services work orders are included on standard work order reports. See *User Guide: QAD Service/Support Management* for details.
- Work orders created by entering flow scheduled orders in Flow Schedule Maintenance (17.13.3) that do not include references to existing work orders are managed in the Flow Schedule module. See *User Guide: QAD Lean Manufacturing*.

**Fig. 6.4**  
Work Order Maintenance (16.1)

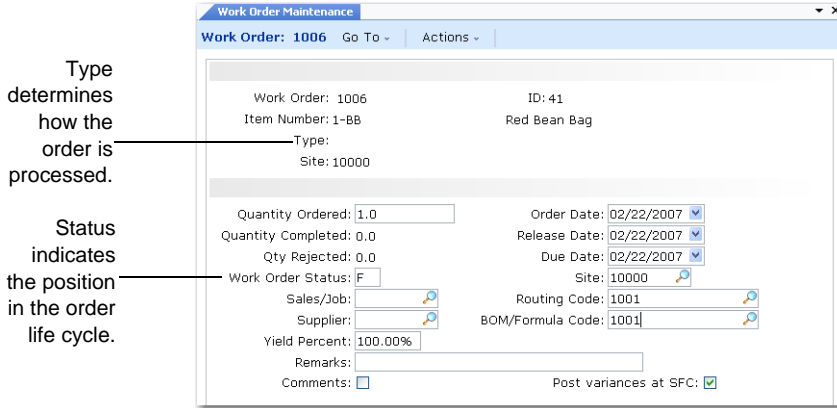

Important elements of a work order include:

- The type, which identifies the source of the order and indicates how it should be processed.
- The status, which determines where a work order is in its life cycle.
- The bill of material (BOM), which lists the quantities of components required to fulfill an order.
- The routing, which lists the operations required to complete the order.

**Note** The BOM and routing are also called a process sheet.

These elements are discussed in the following sections.

## Work Order Type

Most work orders are entered with a blank type. These represent normal manufacturing orders with a standard product structure and routing. The other types indicate special kinds of work orders.

Table 6.2 lists work order type codes.

**Table 6.2**  
Work Order Types

Type Code	Description	Type Code	Description
Blank	Standard	S	Scheduled
F	Final Assembly	C	Cumulative
R	Rework	W	Flow
E	Expense		

All work order types are similar in terms of planning, inventory, and accounting. They differ in their default bills, routings, and status codes. These defaults are shown in Table 6.3 for each order type.

See “Work Order Status” on page 82 for more details.

**Note** Scheduled and cumulative orders are managed using repetitive functions and are not included in this table.

**Table 6.3**

Work Order Type Defaults

Work Order Type	Type Code	Default Bill	Default Routing	Default Status
Standard	blank	Standard	Standard	Firm Planned
Rework	R	Parent Item	None	Allocated
Final Assembly	F	Sales Order	Standard	Exploded
Expense	E	None	None	Released
Flow	W	Standard	Standard	Exploded

### Rework Work Orders

Use rework orders to manage repair, reprocessing, or completion of non-conforming items. A rework order has the parent item as its only component, and no routing.

After creating a rework order, you can modify its bill and routing by adding components and operations before it is released. If additional items are needed, use Work Order Component Issue (16.10) or directly modify the bill using Work Order Bill Maintenance (16.13.1).

If rework activity is a common procedure, consider establishing a rework routing in Routing Maintenance (14.13.1) and attaching it in Work Order Maintenance (16.1), or create one in Work Order Bill Maintenance (16.13.1).

If you are using the Service/Support Management module to receive items from customers and rework them, you can establish default service routings in Service Item Maintenance (11.3.7).

In Work Order Maintenance (16.1), set the WIP account, sub-account, cost center, and project to an appropriate expense account for posting rework costs.

### Final Assembly Work Orders

Final assembly (FAS) orders are used to manufacture configured products of type assemble to order (ATO). Kit-configured items do not require a work order. These are indicated by a Pur/Mfg code of Configured in Item Master Maintenance (1.4.1). FAS orders are generated when a sales order for a configured product is released to manufacturing using Sales Order Release to Work Order (8.13).

An FAS order uses the standard item routing, but its BOM contain only the items specified in the sales order configuration. Release and process FAS orders the same as regular work orders.

See *User Guide: QAD Sales* for more information about configured items.

### Expense Work Orders

Use expense work orders for non-inventory jobs, such as engineering prototypes or design projects. Expense work orders have no bill or routing, but you can attach these manually as needed.

**Note** You should define a separate site, item code, and product line for expense orders to keep their planning and manufacturing separate from regular manufacturing.

To separate cost accounting, specify an expense account rather than the default WIP account. Or use the Project field to track expenses in the GL.

If you process expense work orders frequently, streamline the process by:

- 1 Creating a product line with account numbers for this type of work.
- 2 Creating an item of type E to use for expense orders. Define a blank order quantity to prevent planning functions from treating it like a normal item.
- 3 Creating a status code that restricts all inventory transactions and assign it to the item.

### Scheduled Work Orders

Scheduled work orders are generated by the system when repetitive schedules are entered. Like standard work orders, they have a standard work order bill and routing.

A scheduled work order cannot be processed as a standard work order unless you change its status to Allocated or Released. Changing a scheduled order to a regular order automatically updates the repetitive schedule to exclude it; however, the work order type remains Scheduled.

See Chapter 8, “Advanced Repetitive,” and Chapter 9, “Repetitive,” for more information on scheduled orders.

### Cumulative Work Orders

Cumulative orders are generated by the system to track repetitive production costs. They cannot be processed using work order functions.

See “Managing Cumulative Orders” on page 135.

### Routable Work Orders

The system manages one other kind of work order that is not represented by a separate type code. Subassemblies can be set up so that work orders are automatically created for them when a parent item is allocated or released using:

- Work Order Release/Print (16.6)
- Multiple Work Order Release/Print (16.7)

To do this, set the Pur/Mfg code for the item to Routable in Item Master Maintenance (1.4.1) or Item Planning Maintenance (1.4.7). A work order for a routable item has the same number as the parent work order, but a unique work order ID.

These work orders can be allocated, released, and used for processing component issues, inventory receipts, and shop floor control transactions. When the subassembly is finished:

- Process a work order receipt from the routable work order.
- Then issue the subassembly as a component to the parent work order.

### Flow Work Order

Flow work orders are generated by the system when flow scheduled orders are entered and do not include a reference to an existing standard work order. Like standard work orders, they have a standard work order bill and routing.

A flow work order cannot be processed as a standard work order. It is automatically updated when you process the associated flow scheduled order.

### Work Order Status

Work order status codes correspond to stages in a work order's life cycle:

- Planned
- Firm planned
- Batch
- Exploded
- Allocated
- Released
- Closed

The status of a work order determines how much control you have over its bill, routing, inventory allocations, inventory transactions, and labor feedback:

- You cannot make any changes to orders with status Planned. These are managed by MRP.
- For orders with status Firm Planned, you can change the dates and quantities as needed, and specify an approved alternate bill or routing.
- For orders with status Exploded, Allocated, or Released, bills and routings can be modified or alternate ones specified.

A work order progresses from one status code to the next and, unless prematurely released, does not return to an earlier status.

**Table 6.4**  
Work Order Life Cycle

Type Code	Description	Life Cycle
Blank	Standard	Planned—Firm Planned—Exploded—Allocated—Released—Closed
F	Final Assembly	Exploded—Allocated—Released—Closed
R	Rework	Allocated—Released—Closed
E	Expense	Released—Closed
S	Scheduled	Exploded—Closed

Type Code	Description	Life Cycle
C	Cumulative	Released—Closed
W	Flow	Exploded—Deleted (system action)

After entering an order, change its status to Firm Planned, Exploded, or Allocated using Multiple Work Order Status Change (16.8). Table 6.5 shows how the status changes affect a work order's BOM and routing.

**Table 6.5**  
Effect of Status Change on Bill and Routing

	Planned	Firm Planned	Exploded	Allocated	Released	Closed
Bills	Bill created		Components frozen	Inventory allocated	Inventory picked	
Routings		Routing created and scheduled	Routing operations frozen			

### Planned

Planned orders are generated by MRP and are replanned as requirements change. You cannot record inventory transactions or labor feedback against them, or change quantities, dates, bills of material, or routings.

Approving a planned work order with Planned Work Order Approval (23.10) changes its status to firm planned.

See Chapter 13, “Material Requirements Planning,” for more information about planned orders.

**Note** Work orders with statuses other than Planned have fixed quantities and due dates and are therefore not replanned by MRP.

### Firm Planned

A firm planned order has been approved. This is the default status for an order you create in Work Order Maintenance. MRP does not replan these orders, but instead, generates action messages as needed.

A firm planned order has a work order bill and a routing with scheduled operations. These are not fixed. Bills are re-exploded by MRP, while routings are re-exploded by CRP. Both are re-exploded when the status is changed to Exploded, Allocated, or Released. This allows entry of a work order for a fixed quantity and date, while reflecting future engineering changes in the bill or routing as the order advances toward release.

You cannot record inventory transactions or labor feedback against firm planned orders.

### Batch

A batch status indicates that this is a firm planned order entered in batch. This method speeds up processing for large numbers of orders. The system does not create and explode bills or routings for these orders until their status changes. As a result, MRP does not recognize any component demand.

Enter batch work orders manually as needed, or create them automatically for routable components when changing the order status to Allocated or Released. Use Multiple WO Status Change (16.8) to change order status at the appropriate time.

You cannot record inventory transactions or labor feedback against a batch order.

### Exploded

Exploding a work order recalculates the work order bill and freezes the bill along with the routing. The bill and routing can only be changed manually—until the order is released.

**Note** When the explosion takes place, any requirements for phantom items are not exploded into requirements for their lower-level components.

You cannot record inventory transactions or labor feedback against work orders with status Exploded.

### Allocated

Allocated orders are extensions of exploded orders and are used for inventory transactions. You cannot record labor feedback against orders with status Allocated. Allocated orders differ from exploded orders in the following ways:

- Inventory allocations are made for all of the required components.
- When the work order bill is created, the system explodes through the requirements for phantoms if needed, using up quantities of phantom items already in inventory before creating requirements for their components.
- Work orders are automatically created for components with Pur/Mfg codes set to Routable in Item Planning Maintenance (1.4.7). These orders normally have a status of Batch.

### Released

A released order is like an allocated order except that detail allocations are made for its components and its operations are scheduled. Depending on which program is used, a picklist or routing can be printed when an order is released. The picklist uses detail allocations to indicate the specific inventory detail records to pick for the order.

You can record inventory transactions or labor feedback against work orders with status Released.

### Closed

Work orders are typically closed when the items are received. This status is useful for reporting. For most purposes, this ends the life cycle. You cannot process inventory transactions for closed orders. However, additional labor can be reported until either:

- The operations are closed in Shop Floor Control.
- Work Order Accounting Close (16.21) is executed.

## Routing Code

Work order routings, identified by routing codes, specify the operations, or steps, required to manufacture an item. Set up routings and operations using the Routings/Work Centers module. Link routings to items using Item Master Maintenance (1.4.1) or Item Data Maintenance (1.4.3).

When a work order is created, the standard routing is copied into it. As work progresses, required changes can be made to this copy using Work Order Routing Maintenance (16.13.13). This way, what actually happens can be compared to the standard. Monitor work order operations using the Shop Floor Control module.

See “Routings and Work Centers” on page 17.

See Chapter 7, “Shop Floor Control,” on page 103.

Once the work order status is Exploded, Allocated, or Released, no more changes can be made to the routing.

If the operation-based yield calculation method is used for the item on the work order, any manual changes to the Yield field in the work order header have no effect on component requirements.

When the work order is exploded, the system always uses the yield percentages from operations in the item’s routing to determine component quantities.

See “Yield” on page 29.

## BOM/Formula

The work order BOM is derived from the item’s product structure, defined in Product Structure Maintenance (13.5) or Formula Maintenance (15.5), and the quantity ordered. Inventory allocations and issues are based on the bill. MRP uses the bill of material to calculate component demand.

See “Material Requirements Planning” on page 267.

As work progresses, you can make any required changes to the work order BOM. This way, you can compare what you actually use with the standard. Item quantities allocated, issued, or picked are also maintained in the BOM.

Once the work order status is Exploded, Allocated, or Released, no more changes can be made to the BOM. However, you can reassign the picking location for items on the bill even if the work order status is Allocated or Released. Use Work Order Bill Maintenance (16.13.1) to make adjustments.

## Scheduling Work Orders

MRP uses a combination of work order due date, release date, and manufacturing lead time to schedule work orders.

**Fig. 6.5**  
Work Order Maintenance (16.1)

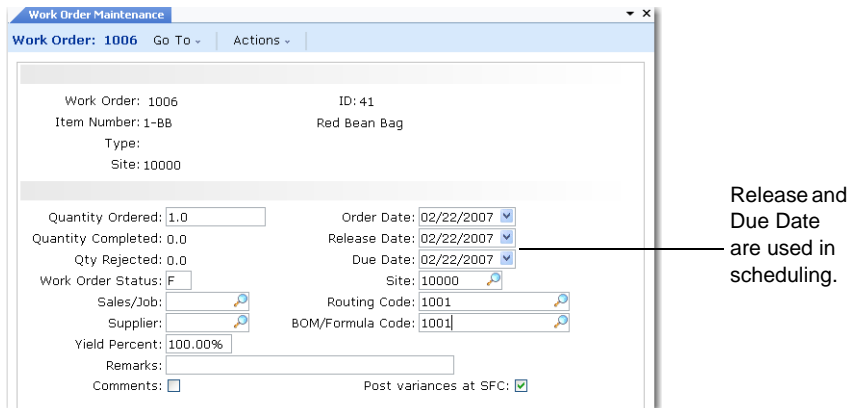

- The due date determines the date when inventory is needed and an order should be complete. MRP uses order due dates to determine when quantities will be available to replenish inventory.
- The release date is the date when an order is scheduled for release to the shop floor. MRP uses the release date to determine when components are required. When an order is released, the scheduled release date is changed to the date actually released. For more details, see “Releasing Work Orders” on page 89.
- The release and due dates for an order are offset by the lead time for the item produced. For example, if it takes an average of five working days to manufacture an item, the release and due dates are separated by one week. This ensures that an order for that item will be completed on time provided that it is released on time.

## Manually Controlling Due Dates

When you create an order in Work Order Maintenance, the due date is calculated from the release date. The calculation begins by setting the release date to the current date, then uses the manufacturing lead time and shop calendar to calculate the due date.

To define either the release or due date and have the program calculate the undefined date, enter the defined date and enter a question mark for the date you want calculated. The system calculates the date for the field containing the question mark using the date from the other field and the operation times from the item routing.

- If you enter a release date and enter a question mark in the Due Date field, the system calculates the due date by starting at the beginning of the release date and forward scheduling starting with queue time for the first operation.
- If you enter a due date and enter a question mark in the Release Date field, the system starts at the end of the due date and backward schedules by starting with the last move time for the last operation.
- If you leave both dates blank, the release date is set to today’s date and forward scheduling is used.

**Note** In all cases, the order quantity is used in calculating run time.

**Example** Figure 6.6 illustrates two schedules created based on the data listed in Table 6.6. The schedule is generated for 100 items, assuming six-hour shop days.

**Table 6.6**  
Sample Schedule Setup

	Queue	Setup	Run	Subcontract
Operation 10	6	1	.05	
Operation 20				1 day
Operation 30	5		.01	

**Fig. 6.6**  
Operation Times

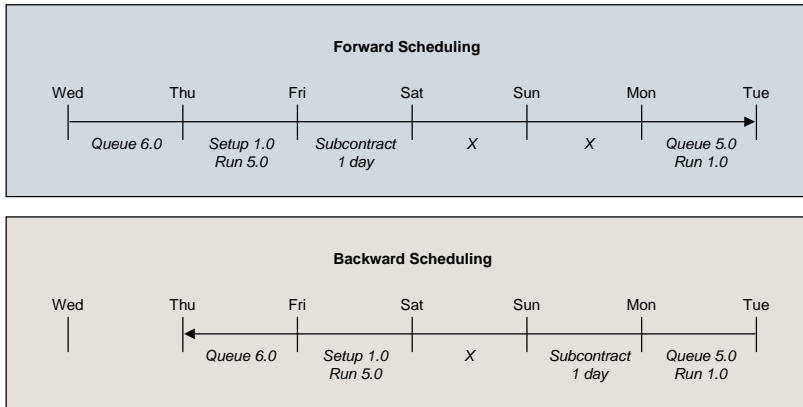

Different release and due dates are possible using forward versus backward scheduling. This is because some lead time components are scheduled in shop days and some in calendar days. A shop day lead time component may be in effect over a weekend in one direction, whereas in the opposite direction, a calendar day component may be in effect.

### Lead Time Calculations

The system uses an average manufacturing lead time calculated from averages of queue, setup, run, subcontract, wait, and move times for routings. The calculation assumes the average order quantity for the item-site or item.

The operation start and stop dates indicate when an order will occupy a work center. Queue time precedes the start date. Setup, run, and subcontract times fall between the start and stop dates. Wait and move times follow the stop date.

When an order quantity differs significantly from the average order quantity, the system may allow too little or too much time to complete the order. The greater the difference between the actual quantity ordered and the average order quantity, the less likely it is that these dates will be realistic or reasonable.

See “Lead Times” on page 27 for details.

### Scheduling Operations

The distinction between setup and run time is important when more than one machine is used to perform an operation.

**Example** Each machine takes four hours to perform an operation on 100 units and each requires an hour of setup time.

**Table 6.7**  
Operation Lead Time with Multiple Components

	<b>Setup</b>	<b>Run</b>	<b>Packaging</b>	<b>Inspection</b>
One Machine	1 hour	8 hours	16 hours	8 hours
Two Machines	1 hour	4 hours	16 hours	8 hours
	1 hour	4 hours		

In Table 6.7, if you decide to make 200 units with one machine, it takes nine hours (setup plus run). If you then decide to use two machines, it takes five hours for each machine, because the setup time is the same for each, but the run time is halved.

Some adjustments may be necessary when operations overlap. This occurs when some units proceed from one operation to the next before all units for that operation are complete. This reduces the aggregate lead time for completing multiple operations. Specify the number of overlap units in Routing Maintenance (14.13.1).

### Rescheduling Operations

If you modify the operation start and end dates, changes are reflected on CRP and work order dispatch reports. However, executing Recalculate Capacity Plan (24.1) will return the schedule to the original dates.

To prevent this, do not recalculate Exploded, Allocated, or Released orders. You can also modify the queue or wait time for the operation, rather than its start date.

See “Executing CRP” on page 286 for more details.

## Modifying Work Orders

Every work order has a BOM and a routing code, which determine the order’s product structure and routing. When a routing or BOM code is blank, it defaults to the item number value. You can specify these for each daily scheduled requirement. Modify these codes as needed in Work Order Maintenance (16.1) and then re-explode the order.

Re-explode Planned, Firm Planned, or Batch orders as needed by running MRP or by changing the work order status to Exploded, Allocated, or Released.

### Modifying Work Order Bills

Often you must modify the bill of a rework order by adding components. Sometimes, as well, you must modify the bill of a regular work order. For example, there may be an engineering change order needing immediate implementation for all work-in-process, including orders that have been exploded, allocated, or released.

How you make a replace an existing component with a new one depends on the work order status.

- If an order has been released, you can issue the new component and return the old one. This results in an unfavorable material usage variance for the new component and a favorable usage variance for the old one. Use Work Order Bill Maintenance (16.13.1) to add the new component to the work order before issuing it.

- If an order is allocated or exploded, use Work Order Bill Maintenance to add the new component, updating the quantity required and quantity allocated, and delete the old one.

After modifying a work order bill, you should not change the status back to Firm Planned, since that causes the standard bill to be re-exploded.

## Modifying Work Order Routings

Use Work Order Routing Maintenance (16.13.13) to add, delete, or change the routing of a work order that is exploded, allocated, or released.

In general, the start and stop dates for work order operations are not frozen. The system automatically reschedules the operations from the due date in any of the following situations:

- A work order is processed in Work Order Maintenance (16.1) and the initial status is Batch, Planned, or Firm Planned.
- A work order is processed using Work Order Maintenance and the final status is Firm Planned.
- A work order's due date changes.
- A work order is replanned by CRP.

**Note** If you are using the Advanced Repetitive module, you cannot add a routing operation to a cumulative order using Work Order Routing Maintenance. Instead, you must change the routing and roll up the cost again. See “Advanced Repetitive” on page 113.

## Releasing Work Orders

Inventory can only be issued or received against a released work order.

- Release orders one at a time using Work Order Release/Print (16.6).
- Release multiple orders at the same time using Multiple Work Order Release/Print (16.7).
- Release orders in Work Order Maintenance (16.1) by changing their status to Released. This method does not let you print a picklist or routing, but it still explodes phantom components and creates work orders for routable components.

Releasing a work order has the following effects:

- Items not previously allocated are detail allocated. The system uses the default picking logic defined in Inventory Control (3.24).
- The picklist is printed, showing the location and quantity of the material in Picked status for this order.
- The first operation is moved to the queue status if Move First Operation is Yes in Work Order Control (16.24). See page 77.

It is possible to prevent work orders for specified items from being released to the shop floor. For example, you might want to restrict from release any items that are going to be phased out or obsoleted in the near future.

To use this feature, use Item Status Code Maintenance (1.1.5) to identify one or more status codes that you want to associate with items that cannot have work orders released. Assign REL-WO to these codes as a restricted transaction, then enter one of these codes in the Status field in Item Master Maintenance (1.4.1) or Item Data Maintenance (1.4.3) for any item you want to prevent from being released on a work order.

If you attempt to release an order for such an item in Work Order Maintenance (16.1), Work Order Release/Print (16.6), or Multiple WO Release/Print (16.7), the system displays an error message.

## Key Items

If there are shortages of important work order components, you can prevent the system from releasing an order or printing a picklist. Do this by designating these items as key items in:

- Item Master Maintenance (1.4.1)
- Item Inventory Data Maintenance (1.4.5)
- Item-Site Inventory Data Maintenance (1.4.6)

You can also change any component on a work order bill to a key item using Work Order Bill Maintenance (16.13.1).

If detail allocations cannot be made for the total quantity required for a key item, the order is not released. To check availability of non-key items before releasing an order, use Work Order Component Check (16.3.18).

## Splitting Work Orders

Even if you check for potential shortages before an order is released, quality problems and inaccurate inventory balances may result in a shortage of components. These shortages can be monitored using Work Order Bill Shortage Report (16.16) and Work Order Bill Shortage by Item Report (16.17).

If necessary, use Work Order Split (16.9) to move part of a work order through remaining operations, while the rest waits for needed components. You can split open operations between the original and new work order.

When an order is split, each portion keeps the same work order number, but has a unique ID. Component costs are typically tracked under the original ID. However, when you split the order, you are prompted to divide the components between the original work order and the new work order. You can divide component only if they have not been issued. Use Work Order Bill Maintenance (16.13.1) to adjust the bills as required. Labor is tracked separately for each ID on the work order.

## Creating Picklists

After you release a work order, you can print its picklist. The picklist lists the component requirements and the sites, locations, lot/serial numbers, and reference numbers for the items to be issued. The system creates detail allocations when an order is released, regardless of whether or not you print a picklist. Detail allocations reserve specific quantities in inventory for a work order.

The picking logic used is determined by settings in Inventory Control.

You can release an order without printing a picklist and routing, but you cannot print a picklist for an order without releasing it.

In a picklist, floor stock appears separately, without site or location. Floor stock should have issue policy set to No for the item-site or item.

For an order with several operations, components can be grouped together on separate picklists by setting their lead time offset (LT Offset) to indicate when they are required with respect to the release date. Define lead time offset in Product Structure Maintenance (13.5) or Formula Maintenance (15.5).

See *User Guide: QAD Master Data* for details.

## Reprinting Picklists

You may need to reprint a picklist if not all items were available when it was first issued. Use Work Order Release/Print (16.6) and set Reprint Picked Quantities to No (the default). All items that were not available before are listed.

Another way to reprint a picklist while tracking components already issued to an order is to change the status to Allocated, then re-release the order.

Changing the status to Exploded is possible, but this can cause differences in how phantom use-up logic is applied. If no components have been issued and no changes made to the work order bill or routing, then the status can be changed to Firm Planned, Exploded, or Allocated before re-releasing. Changing the status to Firm Planned eliminates changes entered manually to the work order bill or routing.

## Issuing Components

Work order operations begin when a work order is released and its components issued. Monitor operations using the Shop Floor Control module.

See Chapter 7, “Shop Floor Control,” on page 103.

There are three ways to issue inventory to a work order:

- Issue inventory directly with Work Order Component Issue (16.10).
- Issue inventory as completed products are received with Work Order Receipt Backflush (16.12).
- Issue inventory, report labor, and receive items with Work Order Operation Backflush (16.19).

Inventory transactions occur at different points depending on which method you use. Component QOH is reduced at a later time using the backflush method.

Work Order Receipt Backflush combines the functions of Work Order Component Issue and Work Order Receipt. You can also backflush quantities different from those received. Either method keeps track of the inventory transactions used to issue components to a work order and excludes floor stock, which is issued using an unplanned issue transaction.

For more on using Work Order Receipt Backflush, see “Subcontract Operations” on page 93.

## Work Order Component Issue

If all components were picked from the locations printed on the work order picklist, they can be issued automatically by setting Issue Picked to Yes. This reduces manual entry because it sets the default sites, locations, lot/serial numbers, references, and quantities from the detail allocations on the picklist.

**Fig. 6.7**  
Work Order Component Issue (16.10)

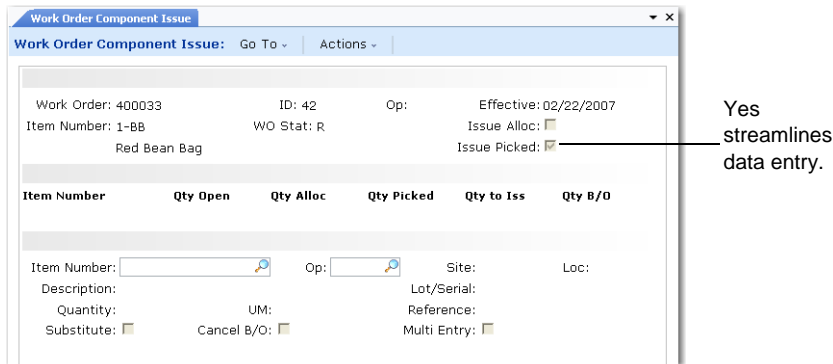

Work Order Component Issue: Go To - Actions -

Work Order: 400033 ID: 42 Op: Effective: 02/22/2007  
 Item Number: 1-BB WO Stat: R Issue Alloc:   
 Red Bean Bag Issue Picked:

Item Number	Qty Open	Qty Alloc	Qty Picked	Qty to Iss	Qty B/O
Item Number: <input type="text"/>					
Description: <input type="text"/>					
Quantity: <input type="text"/>	UM: <input type="text"/>			Reference: <input type="text"/>	
Substitute: <input type="checkbox"/>	Cancel B/O: <input type="checkbox"/>			Multi Entry: <input type="checkbox"/>	

Yes streamlines data entry.

Issues are not restricted to what the system has allocated. You can override the selections manually. The work order and inventory balances are updated only after approval of the quantities to issue from inventory.

The system does not prohibit shipments from using inventory already allocated to another order. This makes timing important. The longer the period between the time a picklist is printed and the time it is picked for shipment, the greater the chances inventory will not be available when you finally try to pick it.

In some instances, when an item is not available, it is possible to substitute a different item—Philips head screws for slotted head screws, for example. When this is required, first set up valid substitute relationships in Alternate Structure Maintenance (13.15) or Item Substitution Maintenance (13.19). When a substitute item is issued to a work order, the requirement for the original component item is reduced.

**Note** If you enter additional quantities or negative quantities for an item during Work Order Component Issue or a Work Order Receipt Backflush, the quantity allocated cannot become more than the quantity required or less than zero (0). It is set to the quantity required or the quantity open, whichever is less.

Components issued to a work order are posted to WIP at GL cost.

## Issuing and Receiving Between Sites

You can receive or issue items at a site other than the order creation site. There are two basic scenarios:

- Receive completed items at a site other than the order.
- Issue items to a site other than the order site.

In the first scenario, you receive at Site 2 a work order created at Site 1. First, a receipt transaction is created at Site 1, the order site. Then an issue transfer transaction is created at Site 1, subtracting the received quantity. A balancing receipt transfer transaction is then created at the receiving site, Site 2. Table 6.8 shows this transaction for a quantity of 100.

**Table 6.8**  
Scenario One

Site 1		Site 2	
RCT-WO	100.0		
ISS-TR	-100.0		
		RCT-TR	100.0

In the second scenario, if you issue components from Site 2 for an order created at Site 1, an issue transfer is first created at Site 2, the issuing site. Then a receipt transfer is created at the order site, Site 1, and then the issue work order transaction is created, again at Site 1.

**Table 6.9**  
Scenario Two

Site 1		Site 2	
		ISS-TR	-100.0
		RCT-TR	100.0
ISS-WO	-100.0		

You can specify the issue or receipt location and site on any of these transactions. However, if the order site is defined with automatic locations set to No, the item's default location must exist at the order site. For example, if the part master site and location are Site 3 and Location 99, you would need to create Location 99 at the order site, Site 1, before you could execute the issue or receipt transaction.

**Note** You can specify the item's default location for all sites in Item Master Maintenance (1.4.1); however, since locations often vary by site, you can set up site-specific values in Item-Site Inventory Data Maintenance (1.4.16).

If you are using shipping groups and inventory movement codes, you can enter shipment information and generate shippers during work order issues. The system looks for a shipping group with matching addresses for the issuing and receiving sites and with inventory movement codes that include ISS-WO.

See the Shipping chapter in *User Guide: QAD Sales* for details.

## Subcontract Operations

Work orders with subcontract operations can be used in conjunction with special subcontract purchase orders. When units are returned from a supplier with a subcontract purchase order, the system recognizes the value added to the work order, completes units for that operation, and debits the WIP account.

Separate departments, and possibly work centers, should be set up for outside processing to distinguish them from internal operations. For example, if all subcontract work center codes begin with a common character such as S, it is easy to identify them on Work Order Dispatch Report (16.18) and other reports. Departments and work centers can be defined more specifically for individual suppliers, depending on whether operations are performed by a single supplier.

See “Subcontract Operations” on page 29 for more setup details.

### Subcontract Life Cycle

When the Work Orders, Shop Floor Control, and Purchasing modules are used together, the subcontract cycle includes the following steps:

- Work Order Maintenance (16.1) or Planned Work Order Approval (23.10)
- Work Order Component Check (16.3.18)
- Work Order Release/Print (16.6)
- Work Order Component Issue (16.10)
- Work Order Dispatch Report (16.18)
- Purchase Order Maintenance (5.7)
- Purchase Order Receipts (5.13.1)
- Labor Feedback by Work Center (16.20.1) (optional)
- Work Order Receipt (16.11)
- Work Order Accounting Close (16.21)

### Requirements for Subcontract Purchase Orders

Use Work Order Dispatch Report (16.18) and Work Center Dispatch Report (18.4.8) to determine when purchase orders for subcontract operations should be released.

The Work Order Dispatch Report displays the operations scheduled at a work center, sorted by start date. The report includes the item being built, the work order that authorizes the work, standard setup and run times, and the open quantity on the order at that work center.

Use this report to provide work visibility for a specified number of days, determined by the Window Days field. Also use it as a measurement tool for comparing production progress with production plans.

## Receiving Work Orders

When a work order is completed on the shop floor, the items are typically sent to the stockroom.

- Use Work Order Receipt (16.11) to receive items, close the order, and backflush components of final assembly work orders.
- If you did not issue items previously, issue them when completed products are received with Work Order Receipt Backflush (16.12).
- Use Work Order Operation Backflush (16.19) to issue items, report labor, and receive completed items at an operation.

If you use the Shop Floor Control module, you can enter labor feedback and test results at receipt, and report individual operations as completed.

When a work order is received:

- Inventory increases by the amount of the receipt.
- The open order quantity decreases by the amount of the receipt.
- Any reject quantity is written off to the Scrap account and not placed in inventory.

If Auto Lot Numbers is Yes in Item Inventory Data Maintenance (1.4.5), the system automatically assigns the work order ID as the lot number for inventory received from a work order. This is true regardless of the value of Lot/Serial Control for the item.

**Note** If you are using the Regulatory Attributes module, you can set up lot groups for assigning automatic numbers. If defined, lot groups are used rather than the work order ID. See *User Guide: QAD Master Data*.

During receipt, you can set the work order status to Closed. Once closed, no further component issues or completions can be recorded against the order.

See “Closing Work Orders” on page 100.

The system captures the receipt and close date as well as the user ID of the person who received or closed the work order. This information automatically appears on two reports:

- Work Order Status Report (16.3.3)
- Work Order History Report (16.3.6)

Closing a work order does not clear the balance in WIP. This action is done by using Work Order Accounting Close (16.21).

## Receiving and Backflushing

When you backflush components at work order receipt, the system explodes the item product structure by the quantity of the parent item received to calculate the standard component quantities used. Users can control the location and default quantity for backflushing.

In Work Order Receipt Backflush (16.12), specify a location in Backflush Loc. The alternative is to backflush from the default location on the work order picklist.

Two fields in Work Order Receipt Backflush (16.12) enable you to control the default values for quantity to issue, depending on the history of the work order.

**Fig. 6.8**  
Work Order Receipt Backflush (16.12)

Work Order Receipt Backflush

Work Order Receipt Backflush: Go To - Actions -

Work Order: 400033 ID: 42 Effective Date: 08/31/2007  
 Item Number: 1-BB WO Stat: R Receive:   
 Red Bean Bag Backflush:

Quantity Ordered: 100.0  
 Quantity Completed: 100.0  
 Backflush Qty: 100.0  
 Backflush Loc:

Issue Alloc:   
 Issue Picked:   
 Cancel Backorders:

Quantity Calculation Method: Component Required Quantity  
 Backflush Method: Standard Backflush

Back Next

These fields control issue quantity defaults.

**Quantity Calculation Method.** Sets the calculation method used to determine the quantity to issue for all components. The default is Component Required Quantity. Other valid choices are Work Order Bill Qty Per and Phantoms First. You can still adjust each issue quantity on a line-by-line basis in the detail screen.

**Backflush Method.** Defines whether to use the backflush quantity you entered (the default standard backflush) or to include prior issues and receipts against this order.

The two fields work in conjunction with each other. In most cases, you should accept the default. However, in three instances, you obtain more accurate issue quantities by resetting these values:

- The first instance occurs when you issued components to the order or made a partial receipt without issuing all components. In this instance, set the backflush method to Net of Prior Issues and Receipts. This setting factors in prior receipts and issues to derive the Quantity to Issue value.

**Example** If you issue all of a component or more than you need, the quantity to issue is 0. If, however, you receive and backflush 50 out of 100 parents and then receive the remaining 50, the quantity to issue for a component with a Qty Per of 1 is 50. When this is the only special condition, leave Quantity Calculation Method set to Component Required Quantity.

- A variation on the previous example occurs when you complete a partial receipt and then modify the Qty Required and/or the Qty Per values for a component in Work Order Bill Maintenance (16.13.1). For the quantity to issue calculation to take into account full requirements for prior completions, use Net of Prior Issues and Receipts in the Backflush Method field. Otherwise, the quantity to issue reflects component requirements for the open order quantity only.
- The last instance occurs when you change the work order bill Qty Per for a component without recalculating the quantity required. To recalculate the quantity to issue including the revised component Qty Per, use the Work Order Bill Qty Per in the Quantity Calculation Method field.

**Example** The work order bill quantity is reset from 1.0 to 1.5 on an order for 100. With a calculation method of Work Order Bill Qty Per, the quantity to issue is 150. Otherwise, it remains 100. If this is the only special condition on an order, leave Backflush Method set to Standard Backflush.

If you have a combination of the two circumstances, use Net of Prior Issues and Receipts and Work Order Bill Qty Per.

Use the Component Required Quantity option for the Quantity Calculation Method field when rounding or truncation errors may occur during backflush as a result of a component having a small or non-evenly divisible quantity relative to the bill.

If you are completing a partial receipt and want to use up global phantoms before issuing components for the phantom, enter Phantoms First in the Quantity Calculation Method field.

**Example** Ten phantoms are in stock. If you complete a partial receipt backflush for 10 items and the phantom and its components have a quantity per of 1, the phantom quantity to issue is 10. Otherwise, the phantom and its components are calculated proportionally, each with a quantity to issue of 5.

Since phantoms are not defined as phantoms in the work order bill, the Phantoms First option uses the current product structure to identify phantom items.

When you use Work Order Backflush Receipt to receive or close work orders, the system records the system date as the receipt or close date and your user ID. These items appear on two work order reports.

See “Closing Work Orders” on page 100.

## Managing Scrap

Scrap refers to unusable items. In the manufacturing process, there can be two kinds of scrap:

- Components issued to the work order
- Items built by the work order that are unusable

## Component Loss

When additional components are required for a work order because items were lost or unusable, the replacement components should be issued to the work order. This results in an unfavorable material usage variance for the order.

**Fig. 6.9**  
Scrap Cycle

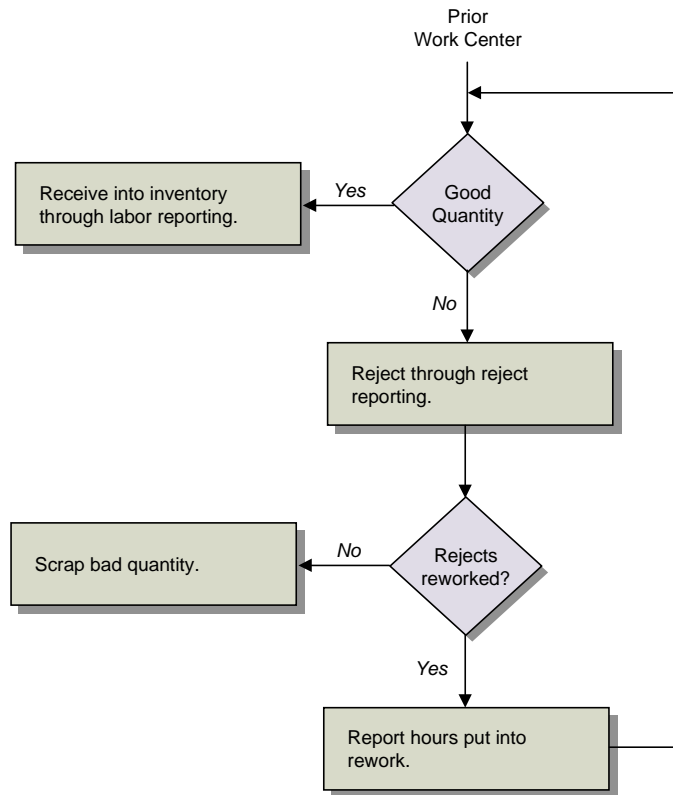

### Product Loss

When products are lost during manufacturing, you can record the loss for the work order when it is received. For an operation, you can record the loss using Shop Floor Control, but this is for reporting only. Shop Floor Control creates WO-SCRAP operation history records but does not update the general ledger.

Only units recorded as rejects during work order receipt affect the general ledger, debiting scrap and crediting WIP. You can use Work Order Receipt, Work Order Receipt Backflush, or Work Order Operation Backflush to update the general ledger.

**Note** Another way to scrap items is by using an unplanned issue and changing the default account debit account to the Scrap account.

### Scrap Quantities by Order

To view scrap quantities by order, regardless of costing method, use Work Order by Order Report (16.3.1).

## Generating Reports

Many of the Work Order Reports (16.3) reflect activities supported by the Repetitive module.

**Table 6.10**  
Work Order Reports

Menu	Report	Description
16.3.1	Work Order by Order Report	Designed for managers who need the information available in Work Order Maintenance (16.1), without work order bill or routing details.
16.3.2	Work Order by Item Report	Designed for managers who need the information available in Work Order Maintenance (16.1), without work order bill or routing detail.
16.3.3	Work Order Status Report	Designed for managers who need information on the current status of work orders, including bills and routings, receipt and close dates, and the user ID of the person who receives or closes them.
16.3.4	Work Order Cost Report	<p>Designed for accountants and managers who need to analyze the costs and variances associated with work orders. This report is normally used for closed work orders.</p> <p>It identifies work order costs, grouping them into five categories: material, labor, burden, subcontract, and method change. Material costs are supported by inventory transaction data for work order components. Labor, burden, and subcontract costs are supported by transactions for operations.</p> <p>If this report is run for work orders that have not been processed by Work Order Accounting Close (16.21), the variances calculated may be incomplete.</p>
16.3.5	Work Order WIP Cost Report	<p>Designed for accountants who need to see how the WIP balance is supported by work order activity. It sorts first by WIP account, then work order, displaying the accumulated material, labor, burden, and subcontract costs, and the cost of receipts and rejects, to arrive at the cost currently in WIP for each order and each WIP account.</p> <p>Activities affecting these costs include component issues, labor feedback, operation completions, purchase order receipts (for subcontract orders), and work order receipts.</p>

Menu	Report	Description
16.3.6	Work Order History Report	Designed for managers and accountants who need to see closed work orders with their bills, routings, date of closure, and user ID of the person who closed them. Components are reported with the quantities required and issued. Operations are reported with the number of units completed, and the expected and actual hours for setup and run time.
16.18	Work Order Dispatch Report	In a job shop, it is important to know which work orders will arrive at a work center and which orders are already there. This information helps you determine priorities and anticipate work load. This report groups this type of information by work center.  The Window field lets you control and filter incoming orders based on the start date of the operation and today's date. For example, when the window is three days, the report includes open work order operations that should be started within three days of today.

**Note** Most of the reports in the Work Orders and Shop Floor Control modules can also be used for Repetitive. In particular, Work Order Cost Report (16.3.4), Work Order WIP Cost Report (16.3.5), and Work Order History Report (16.3.6) play an important role in reporting activity against cumulative work orders.

## Closing Work Orders

To close a work order, complete the following steps:

- 1 Change the order's status to Closed. You can do this by setting Close to Yes when completed units are received, or by using Work Order Maintenance (16.1).

**Note** When a work order is referenced by a flow scheduled order and you close the flow scheduled order using Flow Schedule Close (17.13.19), the system automatically changes the work order's status to Closed. You can reopen it using Work Order Maintenance. See *User Guide: QAD Lean Manufacturing*.

- 2 Run Work Order Accounting Close (16.21) to post variances, clear WIP, and close outstanding operations. Execute this program regularly, at least at the end of each fiscal month, for completed orders.

The system prevents component issues and work order receipts for a closed work order. If you want to process inventory for a closed work order, you must change its status back to Released.

The system records the work order close date (the system date). The system also records the user ID of the person who closed the work order.

The work order close date and user ID are captured when the work order is closed through the following:

- Work Order Maintenance (16.1)
- Multiple WO Status Change (16.8)

- Work Order Receipt (16.11)
- Work Order Receipt Backflush (16.12)
- Work Order Operation Backflush (16.19)

Although you are not prompted to enter the work order close date or your user ID, these items are captured by the system and appear automatically on two work order reports:

- Work Order Status Report (16.3.3)
- Work Order History Report (16.3.6)

Work order close and receipt dates are recorded on discrete work orders only. Scheduled and cumulative work orders, created through Repetitive and Advance Repetitive, do not include this functionality.

The work order close and receipt dates do not affect the effective date of the accounting close function. GL period control does not apply to the work order and receipt dates.

See “General Ledger Period End” on page 102.

## Work Order Accounting Close

Work Order Accounting Close (16.21):

- Completes open work order operations.
- Calculates and posts work order variances for material, labor, burden, and subcontract costs.
  - Calculates and posts usage variances when the labor quantity used differs from the standard.

For example, if it took six hours to complete an operation scheduled for five hours, a labor usage variance of one hour is posted.

- Calculates and posts rate variances for material and subcontract when cost used differs from standard cost. If pay rates are defined in Actual Pay Rate Maintenance (14.13.21), rate variances are also calculated for labor.
 

For example, when the standard subcontract cost is \$10 and the PO cost is \$12, the subcontract rate variance is \$2.
- Reconciles the WIP account for closed work orders by calculating and posting method change variances for any residual variances. WIP balances cannot be changed after the work order variances are posted.
- Updates current labor and subcontract costs.
- Posts floor stock amounts.

For Repetitive programs, Cumulative Order Accounting Close (18.9) performs the same operations, but only for repetitive work orders. Work Order Accounting Close (16.21) closes both repetitive work orders and standard work orders.

## General Ledger Period End

Since you can enter a GL effective date on work order, shop floor control, and repetitive transactions, a strict procedure is not required to account correctly for activity in the general ledger. Some reports, such as Work Order WIP Cost Report (16.3.5), are sensitive to period-end procedures. Use the following outline to write a procedure that fits your needs.

- 1 All work order, shop floor control, and repetitive transactions should be completed and reviewed before starting the new period, including the following:
  - Work Order Component Issues (16.10)
  - Work Order Receipts (16.11)
  - Work Order Receipt Backflush (16.12)
  - Work Order Operation Backflush (16.19)
  - Labor Feedback by Work Order (16.20.1), by Employee (16.20.2), by Work Center (16.20.3)
  - Operation Complete Transaction (16.20.5)
  - Repetitive Setup Transaction (18.13)
  - Repetitive Labor Transaction (18.14)
  - Non-Productive Labor Feedback (16.20.4)
- 2 The status of all closed work orders should be changed to Closed.
- 3 All open cumulative work orders in the Repetitive module should be changed to Closed.
- 4 Run WIP Material Cost Revaluation (16.22) to update allocated, released, and closed work orders.
- 5 Run Work Order Accounting Close (16.21) and Cumulative Order Accounting Close (18.9).
- 6 Print Work Order WIP Cost Report (16.3.5) and any other time-sensitive reports required.
- 7 After reviewing these reports, proceed with the new period.

## Deleting Work Orders

You can delete work orders using Work Order Maintenance under two conditions:

- They have a status of P (Planned), B (Batch Input Firm Planned), or F (Firm Planned) with a WIP total of zero.
- They have a status of C (Closed), a WIP total of zero, and a valid accounting close record.

Obsolete work orders can also be deleted and/or archived with Work Order Delete/Archive (16.23). Only orders closed with Work Order Accounting Close can be deleted.

# Shop Floor Control

The Shop Floor Control module tracks activities and records operation status and labor times for manufacturing jobs released using the Work Orders module.

***Introduction 104***

Describes the purpose and functions of Shop Floor Control.

***Reporting Labor by Operation 104***

Describes how to report labor using various functions, as well as how to monitor statuses by employee, department, work center, item quantities, time, or operation.

***Recording Nonproductive Labor 107***

Outlines how nonproductive labor can be recorded and how specific types should be categorized.

***Reporting Scrap 107***

Describes how to report scrap with Operation Scrap Transaction.

***Closing Operations 108***

Describes how to close operations using Operation Complete Transaction.

***Generating Reports 109***

Describes how the Shop Floor Control Reports menu displays reports based on certain data.

## Introduction

Use Shop Floor Control to report setup time, hours worked, material scrapped, and the number of units completed for a specific work order operation. This information is used to track the status of work order operations, monitor performance of work centers, and update the general ledger (GL) for manufacturing costs.

The Repetitive and Advanced Repetitive modules contain reports and transactions similar to those in Shop Floor Control. Review Chapter 8 and Chapter 9 for information on these modules.

The WIP Lot Trace (WLT) module affects some features of the Shop Floor Control module. WIP Lot Trace is available as menu option 3.22.13. When activated, additional frames display in some programs. The discussion in this chapter assumes that WLT features are not active.

For details, see Chapter 10, “WIP Lot Trace,” on page 189.

## Reporting Labor by Operation

You can report labor in Shop Floor Control by work order, employee, or work center, using:

- Labor Feedback by Work Order (16.20.1)
- Labor Feedback by Employee (16.20.2)
- Labor Feedback by Work Center (16.20.3)

For each feedback transaction, you must specify an employee code, a department code, and a work center or production line code.

**Fig. 7.1**

Labor Feedback by Work Order (16.20.1)

The screenshot shows the 'Labor Feedback by Work Order' form. The title bar reads 'Labor Feedback by Work Order'. Below the title bar, there are 'Go To' and 'Actions' menus. The form contains the following fields and values:

Work Order: 400033	ID: 42
Operation: 10	Op Status:
Employee: 8001 Susan	Pay Code:
Department: 100	Work Center: 100-01
Shift: 1	Machine:
	Time Ind: Decimal Hours
	Project:
Quantity Completed: 2,000.0	Effective Date: 02/22/2007
Rejects: <input type="checkbox"/>	Operation Complete: <input checked="" type="checkbox"/>
Rework: <input type="checkbox"/>	Move to Next Operation: <input type="checkbox"/>
	Previous Ops Complete: <input checked="" type="checkbox"/>
Start Setup:	
Elapsed/Stop Setup:	Elapsed Setup: 0.000
Start Run:	
Elapsed/Stop Run:	Elapsed Run: 0.000
Comment:	
Down Time:	Down Time Reason:

## Employee

Some companies summarize the hours worked by all employees for an operation and record them in a single transaction. Others record the hours worked by each employee. Use the second method if you want to report on employee efficiency or examine labor rate variances.

You can calculate employee efficiency when you report labor by employee, provided that only one employee works on any given operation.

See “Utilization and Efficiency” on page 112 for more information.

The system calculates labor rate variances by comparing the labor rate defined for an employee in Actual Pay Rate Maintenance (14.13.21) to the standard labor rate for the operation’s work center, defined in Work Center Maintenance (14.5).

**Note** The employee code specified for a transaction does not need to correspond to an actual person. You can set up an employee code in Employee Create (36.1.7.1) to be used for reporting purposes only.

## Department

The department code defaults from the work order routing. The system creates GL transactions using the accounts associated with this department code. Changing the department code changes the accounts used for the GL transactions created by these programs.

## Work Center

The work center code defaults from the work order routing. The system uses the work center setup, labor, and burden rates to calculate costs and create GL transactions. Changing the work center code results in method change variances when the work center rates differ.

## Item Quantities

For each work order operation, you can record the item quantities completed, rejected, and reworked.

**Note** Labor feedback transactions cannot be modified or deleted once they have been processed. To reverse the effect of incorrect transactions, you can enter transactions for negative values.

When you enter a transaction, the system moves either the quantity ordered or the quantity reported complete at the last operation to the operation being reported. Which quantity displays depends on the setting of Move Next Operation for the previous operation. The quantity open for an operation is this starting quantity minus the quantities completed and rejected at that operation.

*Quantity Completed.* The number of acceptable units produced at this operation, used to calculate variances, work center efficiency, and GL transactions:

- If Move Next Operation is Yes, the quantity completed for an operation automatically moves to the next operation. This occurs regardless of whether the previous operation is complete.
- If Move Next Operation is No, the quantity completed for an operation does not affect the quantity open at the next operation.

Set the default value for this field in Shop Floor Control (16.20.24).

*Quantity Rejected.* The number of unacceptable units produced at this operation that cannot be moved to the next operation.

*Quantity Reworked.* The number of unacceptable units requiring additional processing produced at this operation. These do not all need to result in good units that can be moved to the next operation.

Quantities reported as completed, rejected, and reworked do not affect the quantity open for a work order. If the reject quantity significantly reduces the expected receipt quantity for an order, you should use Work Order Maintenance (16.1) to reduce the order quantity to the expected quantity so that MRP plans based on the correct order quantity.

Rejected and reworked quantities are independent of each other. For example, if you report 25 units as rejected and later report 25 units as reworked, the system shows both the reject and rework quantities as 25. If you want to change the reject quantity to zero, you must specify a reject quantity of -25 units.

Reject and rework quantities have no impact on GL, since no transactions are created when they are reported. They are not used to calculate variances or work center efficiency.

## Times

You can enter setup times, run times, and downtimes in decimal hours (D) or clock hours (H). For example, an hour and 15 minutes can be entered as 1.25 decimal hours or 01:15:00.

Enter elapsed setup and run times directly, or let the system calculate them from the start and stop times. For example, for a start time of 08:00:00 and a stop time of 14:45:00, the system calculates an elapsed time of 6.75 decimal hours.

## Operation Status

Operation status codes indicate the detailed status of individual operations. The system automatically assigns status codes to operations as transactions are processed.

*Queue.* An operation's status is automatically set to Queue when material is moved to that operation, either by releasing a work order, entering labor feedback for that operation, or using Operation Move Transaction (16.20.6) to manually move material.

When Move Next Operation is Yes in a labor feedback transaction, the next operation is automatically set to status Queue and quantities reported complete are moved to that operation.

*Setup.* An operation's status changes to Setup when you report setup time for that operation.

*Running.* An operation's status changes to Running when you report run time for that operation. This is not affected by the number of units reported as completed, rejected, or reworked.

*Complete.* An operation's status changes to Complete when you:

- Report it as completed using one of the labor feedback transactions or Work Order Operation Backflush (16.19).
- Close it using Operation Complete Transaction (16.20.5).
- Run Work Order Accounting Close (16.21). For more information, see “Closing Operations” on page 108.

When an operation is complete, you cannot process additional transactions against it. However, you can reopen operations if required using Work Order Routing Maintenance (16.13.13).

*Hold.* Indicates the operation is on hold. This status can only be set manually in Work Order Routing Maintenance.

A blank status indicates an inactive operation. An operation's status is blank when the work order routing is first exploded and remains blank until you record activity for it.

Use Work Order Routing Maintenance to manually change an operation's status, if required.

## Recording Nonproductive Labor

Shop floor control functions let you record nonproductive or indirect labor for employees—for example, preventive maintenance and meetings—and downtime for work centers—for example, machine failures. Shop floor reports use this information when calculating utilization and efficiency.

For nonproductive labor or downtime not associated with a specific work order, use Non-Productive Labor Feedback (16.20.4). Otherwise, record nonproductive labor and downtime using the Down Time field in standard labor feedback transactions.

Nonproductive labor transactions reference reason codes set up in Reason Codes Maintenance (36.2.17) with a reason type of Down.

**Note** Many types of nonproductive labor, such as paid vacations, paid holidays, and paid sick leave, should be handled in a payroll system.

**Fig. 7.2**  
Non-Productive Labor Feedback (16.20.4)

The screenshot shows a software window titled "Non-productive Labor Feedback" with a menu bar containing "Go To" and "Actions". The main area contains the following fields:

- Employee: B JW
- Shift: 1
- Pay Code: Reg
- Project: 500
- Effective Date: 02/22/2007
- Work Center: WC1
- Machine: 20
- Site: 10000
- Dept: 100
- Reason: (empty)
- Type: DOWN
- Time Ind: Decimal Hours
- Start Down: (empty)
- Elapsed/Stop Down: 1.25
- Elapsed Down: 0.000
- Comment: Plant Meeting

You can review recorded downtime using Down Time Report (16.20.13.16) or Down Time by Reason Report (16.20.13.17).

## Reporting Scrap

You can use Operation Scrap Transaction (16.20.7) to report scrap of partially completed finished-goods items at a work order operation. This program generates WO-SCRAP operation history records for transactions and has no effect on GL accounts.

The first frame is used to identify the work order operation. Use the last frame to enter quantities scrapped and the corresponding reason codes.

**Fig. 7.3**  
Operation Scrap Transaction (16.20.7)

The screenshot shows the 'Operation Scrap Transaction' window. It contains the following fields and values:

- Work Order: mat100
- Item Number: 1-BB
- Operation: 10
- Effective Date: 02/22/2007
- Employee: 0001
- Work Center: 100-01
- Department: 100
- Project: 500
- ID: 43
- Red Bean Bag
- Shift: 1
- UM: EA
- Conv: 1.0000
- Machine: Assembly
- Assembly Dept.
- New Assembly Machine
- Work Order Status: R
- Op Status:

Quantity	Reason	Quantity	Reason
1.0	expired	0.0	
0.0	size	0.0	
0.0		0.0	
0.0		0.0	
0.0		0.0	
0.0		0.0	

## Closing Operations

You can close an operation by running Operation Complete Transaction (16.20.5). Quantity completed for an operation needs to be entered in any of the Labor Feedback Transactions (by Work Order, Employee, or Work Center).

Setting Previous Ops Complete to Yes closes all previous open operations. For these operations, the system reflects quantity completed at the current operation being closed. The system calculates labor using the standard setup and run times for the change in completed quantity in prior operations.

**Fig. 7.4**  
Operation Complete Transaction (16.20.5)

The screenshot shows the 'Operation Complete Transaction' window. It contains the following fields and values:

- Work Order: mat100
- Item Number: 1-BB
- Operation: 10
- Operation Status: COMPLETE
- Work Center: 100-01
- Department: 100
- Project:
- ID: 43
- Red Bean Bag
- Machine:
- Quantity Ordered: 5.0
- Quantity Completed: 0.0
- Qty Rejected: 0.0
- Effective Date: 02/22/2007
- Previous Ops Complete:
- Comment:

For example, if a work order has five open operations: 10, 20, 30, 40, and 50, and no completions were reported for any of these operations, when operation 50 is closed for a quantity of 100, the system optionally closes operations 10, 20, 30, and 40 for 100 units. However, if operation 50 is closed for 75 units and 90 units had been previously reported as complete at operation 20, the system closes operations 10 and 20 for a quantity of 90 units, and operations 30 and 40 for a quantity of 75 units.

Operation	Previously Completed	Completed
10	0	90
20	90	90
30	0	75
40	0	75
50	0	75

If operation 40 was closed for a quantity of 85 units, the system closes operation 30 for a quantity of 85, and operations 10 and 20 for a quantity of 90.

Operation	Previously Completed	Completed
10	0	90
20	90	90
30	0	85
40	85	85
50	0	75

**Note** Work Order Accounting Close (16.21) closes open operations using the same logic.

Closed operations do not contribute to the projected load for a work center.

## Generating Reports

The Shop Floor Control Reports menu (16.20.13) contains reports that display data based on the following:

- Transactions
- Downtime
- Input and output
- Utilization and efficiency

### Transactions

Transactions are created when you record labor feedback, nonproductive labor, downtime, and operation completions. You can review these transactions by work center, work order, or employee.

The system automatically assigns a transaction number and transaction type that identifies the operation history record. Table 7.1 lists the system-generated types and the name of one or more of the programs that creates the transaction.

**Note** Many of these transactions are created in more than one program. In this case, the table simply indicates one or more typical programs associated with the transaction and is not intended to be a complete list.

**Table 7.1**  
Operation History Transaction Types

<b>Transaction Type</b>	<b>Description</b>	<b>Program</b>
BACKFLSH	Advanced Repetitive labor and material usage.	Backflush Transaction (18.22.13)
CLOSE	Operation closed.	Cumulative Order Close (18.22.10)
DOWN	Non-productive labor reported for Shop Floor Control functions.	Labor Feedback by Work Order (16.20.1)
DOWNTIME	Downtime hours reported for Repetitive and Advanced Repetitive functions.	Repetitive Labor Transaction (18.14) Down Time Transaction (18.22.20)
EXPENSE	Expense consumed for Customer Services functions.	Call Activity Recording (11.1.1.13) Project Activity Recording (10.5.13)
FLOORSTK	Floor stock inventory expense posted at order close.	Post Accumulated Usage Variance (18.22.9)
LABOR	Labor hours reported for Repetitive, Advanced Repetitive, and Customer Services functions.	Repetitive Labor Transaction (18.14) Run Labor Transaction (18.22.14) Call Activity Recording (11.1.1.13) Project Activity Recording (10.5.13)
MOVE	Moved to next operation.	Labor Feedback by Work Order (16.20.1)
MUV-CMP	Material usage variance posted for component usage variance at order close.	Post Accumulated Usage Variance (18.22.9)
MUV-WIP	Material usage variance posted for WIP material scrap usage variance at operation close.	Post Accumulated Usage Variance (18.22.9)
RBUV	Run labor burden usage variance posted at operation close.	Post Accumulated Usage Variance (18.22.9)
REWORK	Quantity reworked and labor hours posted.	Rework Transaction (18.22.17)
RLUV	Run labor usage variance posted at operation close.	Post Accumulated Usage Variance (18.22.9)
SBUV	Setup labor burden usage variance posted.	Post Accumulated Usage Variances (18.22.9)
SCRAP	Quantity scrapped at an operation.	Operation Scrap Transaction (16.20.7)
SETUP	Setup hours recorded.	Setup Labor Transaction (18.22.15)
SLUV	Setup labor usage variance posted.	Post Accumulated Usage Variances (18.22.9)
SUBCNT	Subcontract quantity received or returned at an operation.	Purchase Order Receipts (5.13.1) Purchase Order Returns (5.13.7)

Table 7.1 — Operation History Transaction Types — (Page 1 of 2)

Transaction Type	Description	Program
SUBSHIP	Quantity of WIP shipped to a subcontractor.	Sub Shipper Issue (18.22.5.11)
SUV	Subcontract processing usage variance posted at operation close.	Post Accumulated Usage Variance (18.22.9)
TRANSFER	Quantity of WIP transferred to another cumulative order at operation close.	Cumulative Order Close (18.22.10)
VAR-POST	Labor variance posted at work order receipt.	Work Order Receipt Backflush (16.12)
WIPADJ-I	Quantity adjusted for input queue.	WIP Adjust Transaction (18.22.21)
WIPADJ-O	Quantity adjusted for output queue.	WIP Adjust Transaction (18.22.21)
WIPADJ-R	Quantity adjusted for reject queue.	WIP Adjust Transaction (18.22.21)
WO-CLOSE	Work order accounting close post.	Work Order Accounting Close (16.21)

Table 7.1 — Operation History Transaction Types — (Page 2 of 2)

Use either of the following reports to review operation history records:

- Operation Transaction Browse (17.13.8)
- Operation Transaction Detail Inquiry (16.20.13.9)
- Operation Transaction Detail Report (16.20.13.33)

**Note** This enhanced report is available only in .NET UI.

Use Operations Numbering Report (16.20.13.22) to review operation transaction history by number or date range. Transaction sequence numbers apply to the database as a whole; as a result, transactions within a domain may appear to have gaps. This report lets you see transactions created in all domains and verify that numbering is sequential.

## Downtime

Review recorded downtime by work center or reason code using the following reports:

- Down Time Report (16.20.13.16)
- Down Time by Reason Report (16.20.13.17)

See “Recording Nonproductive Labor” on page 107.

## Input and Output

Use Input/Output Report (16.20.13.12) to review the load at work centers. You can use this function to compare planned input and output with actual input and output for a given period. The planned input and output data are based on work order operation start dates, standard setup and run times, and the work center or shop calendar. Actual input is based on the quantities moved to a work center, while actual output is based on the quantities completed at a work center.

## Utilization and Efficiency

Two key measures of performance are utilization and efficiency. Utilization is the ratio of the total number of hours worked to the total number of hours available to be worked, as defined in the shop calendar.

$$\text{Utilization \%} = \text{Actual Hours Worked} / \text{Clock Time Scheduled} * 100$$

Use Work Center Utilization Report (16.20.13.18) to review this information.

Efficiency is the ratio of the total number of standard hours earned by completing units at operations to the total number of hours worked.

$$\text{Efficiency} = \text{Standard Hours Earned} / \text{Actual Hours Worked} * 100$$

Productivity is the ratio of standard hours earned divided by the number of available hours. It is not reported, but can be manually calculated by multiplying utilization by efficiency.

$$\text{Productivity \%} = \text{Standard Hours Earned} / \text{Clock Time Scheduled} * 100$$

Use any of the following reports to review efficiency data:

- Efficiency by Work Center Report (16.20.13.19)
- Efficiency by Work Order Report (16.20.13.20)
- Efficiency by Employee Report (16.20.13.21)

## Deleting and Archiving Transactions

Depending on the volume of transactions, you may only want to maintain one to three months of history online. Use Operations History Delete/Archive (16.20.23) to archive old transactions and delete them from the database.

Use this programs carefully to prevent deleting data or archiving data that may be needed online. While recovery of archived data is relatively easy, it is not possible to recover deleted data that has not been archived.

# Advanced Repetitive

Repetitive schedules perform the same functions as work orders in a process environment. This chapter discusses how repetitive schedules are created and exploded, and how inventory is issued when the process is complete.

## ***Introduction*** 114

Outlines the Repetitive and Advanced Repetitive modules and their unique features.

## ***Setting Up Advanced Repetitive*** 116

Defines the basic data and program settings that must be in place to run Advanced Repetitive.

## ***Simulating Schedules in the Workbench*** 126

Describes when and how to set up simulated schedules using Line Schedule Workbench.

## ***Creating Repetitive Schedules*** 129

Defines a repetitive schedule and describes how to update and maintain it.

## ***Exploding Repetitive Schedules*** 130

Defines exploding a schedule and explains how and why to do so.

## ***Using Repetitive Picklists*** 131

Describes why repetitive picklists are used, how to calculate and print them, and how to transfer inventory if necessary.

## ***Managing Cumulative Orders*** 135

Describes how to create, close, and maintain cumulative orders.

## ***Executing Repetitive Transactions*** 138

Describes when repetitive transaction programs are used and how they relate to shipping documents, transaction data, rate variances, and method change variances.

## ***Generating Repetitive Reports*** 147

Describes different kinds of repetitive reports.

## ***Managing Subcontracting*** 148

Describes how to set up subcontract data, operations, and other functions in Advanced Repetitive.

## ***Working with Planning and Scheduling Workbenches*** 167

Describes the .NET UI-only Planning and Scheduling Workbenches, provides information to find user information for the workbenches, and describes setup programs in QAD EE for the workbenches.

## Introduction

Repetitive manufacturing is executed with schedules rather than work orders. Schedules require fewer steps and less paperwork to execute and are typical in manufacturing environments that use assembly lines to produce similar products using the same process. Since the same activities are repeated regularly, there is little variation.

Repetitive scheduling enables you to:

- Build to a repetitive schedule.
- Run a production line without finite schedules.
- Run a production line with repetitive schedules, forward scheduled to capacity limits.
- Report production and let MRP adjust inventory plans.

## Advanced Repetitive and Repetitive

You can use one of two ways to manage repetitive production, appropriate in different business environments. The Repetitive module works well when one or more of the following is true:

- Manufacturing lead times are relatively short and batches do not overlap.
- All work in process is complete by the end of each day.
- Work-in-process (WIP) costs are either insignificant or fairly constant.
- The routing does not include subcontract operations.

The Advanced Repetitive module supports manufacturing environments where the following apply:

- Manufacturing lead times are long.
- Continuous processing is in use; lines are dedicated to one item for days, weeks, or months.
- WIP costs are variable or high.
- Subcontracting operations are managed in a release management (just-in-time) environment.
- Batches can overlap and visibility of and control over WIP are necessary.

**Note** The WIP Lot Trace (WLT) module affects some features of the Advanced Repetitive and Repetitive modules. WIP Lot Trace is available as menu option 3.22.13. When activated, additional frames display in some programs. The discussion in this chapter assumes that WLT features are not active. For details, see Chapter 10, “WIP Lot Trace,” on page 189.

## Distinctive Features of Advanced Repetitive

Advanced Repetitive provides features that are not available in the basic Repetitive module.

### Cumulative Work Order Processing

- Ability to post usage variances without having to close a cumulative order.
- Ability to close a cumulative order and transfer work-in-process (WIP) balances to a new cumulative order for easy phase-in of product structure or routing changes. This also supports accounting period cutoffs.
- Automatic start and end effective date assignment for cumulative order expiration dates.

- Expanded WIP inventory visibility and control.
- Addition of WIP accumulators to track cumulative work moved, rejected, reworked, scrapped, and adjusted.

### Scrap, Reject, Rework, and Adjustments Reporting

- Scrap or adjust from either the input, output, or reject queue.
- Record multiple scrap, reject, and rework quantities with reason codes.
- Generate analysis reports, scrap and adjustments usage variance reports, and scrap and adjustments valuation reports.

### Subcontract Processing

- Integration of supplier scheduled orders with Advanced Repetitive supports repetitive purchasing of subcontract services. For example, use Backflush Transaction (18.22.13) to optionally backflush components up to the subcontractor operation and create a cumulative work order to track subcontractor activity.

When the system creates the cumulative work order, it assigns a work order ID and automatically updates blank work order ID fields on subcontract order lines with the new ID.

Also, the system automatically populates the subcontract operation on subcontract purchase order lines. Therefore, you do not have to return to Purchase Order Maintenance programs to enter the work order ID and subcontract operation.

See “Managing Subcontracting” on page 148.

- Subcontract shippers let you create shipment paperwork, register the physical shipment of materials to the subcontractor, and track subcontract activities.
- Using EDI eCommerce to support electronic data interchange (EDI) transactions lets you receive an advance ship notice (ASN) from your supplier to register the receipt of processed materials.

### Non-Milestone Operation Processing

- The Backflush Transaction (18.22.13) and subcontract processing activities let you use non-milestone backflushing. This replaces the Repetitive Labor Transaction in basic Repetitive.
- Non-milestone backflushing uses a demand-pull strategy to determine the units needed from non-milestone operations. The amount depends on the net requirement of the processing milestone operations. The net requirement is satisfied by consuming units in the output and input queues of preceding non-milestone operations until either the requirement is satisfied or another milestone operation is encountered.
- You can use any repetitive transaction at a non-milestone operation.

### Scheduling

- In Advanced Repetitive, the earliest open schedule is always consumed—not just completions over the scheduled quantity for that date.

- Cumulative Completed Maintenance (18.22.2.6) lets you modify the quantity completed on a repetitive schedule. Changes to a schedule's cumulative completed are reapplied to the schedule using the consume-earliest-open logic.
- WIP inventory is visible to the Schedule Explosion (18.22.2.4) and MRP programs. This prevents overplanning for components that might result from not including WIP.
- Schedule Delete (18.22.2.7) enables easy deletion of repetitive schedules and their planned work orders. Limit schedule consumption in the past by deleting schedules left open that fall before a specific date. In Schedule Delete, the date defaults to Monday's date. Use this to establish the earliest open schedule.

Many activities in the two modules are exactly the same or similar. This chapter describes how to use Advanced Repetitive. Chapter 9 describes the features of basic Repetitive that differ.

See “Repetitive” on page 171.

## Setting Up Advanced Repetitive

Repetitive activities assume that base data is already set up. Much of this is the same data that is required by work orders.

- Define master data such as items, sites, and locations. Also set up each employee who will be reporting labor.
- Define bills of material and product structures in the Product Structures module for each item to be scheduled. Also associate each component in the product structure with a routing operation. See page 5.
- Define departments and work centers, routings, and operations in the Routings/Work Centers module. Each work center must have a corresponding location with the same ID as the work center. See page 17.

Within the Advanced Repetitive module, you must complete additional setup activities:

- Set up values in Repetitive Control and Advanced Repetitive Accounting Control.
- Set up production lines by defining line allocations, shifts (if you use them), production line capacities, and changeover times.

### Defining Control Program Settings

If you have previously used the Repetitive module, you must run Cumulative Ord Accounting Close (18.9) to close any open cumulative orders. Then, set the Enable New Repetitive field in Repetitive Control (18.22.24) to Yes.

**Note** In addition to these Repetitive Control settings, use the WIP Transfer Account fields in Advanced Repetitive Accounting Control (36.9.12) to specify the account type, GL account, sub-account, and cost center debited or credited when closing a cumulative order and transferring WIP to a new cumulative order.

**Fig. 8.1**  
Repetitive Control (18.22.24)

*Next Picklist and P/L Prefix.* Enter values to be used for automatic numbering of repetitive picklists.

*Transfer Work in Process.* Enter Yes or No to set the default for the same field in Cumulative Order Close (18.22.10).

*End Eff Default Method.* Specify the method you normally use to set end effective dates on cumulative orders. Choices are:

Blank: Start and end effective dates are not set.

1: Start and end effective dates match the dates of the GL period in effect during the transaction.

2: Start and end effective dates match the calendar start and end effective dates of the month of the transaction.

3: Start and end effective dates cover a number of days, so the transaction effective date falls in that interval.

The setting determines effective date calculation for orders created in the background by repetitive transactions or in batch using Cumulative Order Create (18.22.11).

*End Eff Days.* If End Eff Default Method is 3, specify the number of days that the start and end effective dates cover.

Figure 8.2 shows how the system uses the End Eff Days field to set the start and end effective dates on cumulative orders. In this example, an End Eff Days value of 10 days is entered, as indicated by the diagonally shaded boxes.

**Fig. 8.2**  
Example of End Eff Days Use

November 2000						
Sun	Mon	Tue	Wed	Thu	Fri	Sat
			1	2	3	4
5	6	7	8	9	10	11
12	13	14	15	16	17	18
19	20	21	22	23	24	25
26	27	28	29	30		

End effective date of last cumulative order points to the cell containing '1' (Wed, Nov 1).

Start effective date of next cumulative order points to the cell containing '12' (Sun, Nov 12).

Start effective date of last cumulative order points to the cell containing '4' (Sat, Nov 4).

End effective date of next cumulative order points to the cell containing '11' (Sat, Nov 11).

Date of transaction points to the cell containing '24' (Fri, Nov 24).

**Include Yield.** Set this to Yes to have the system include the yield percent established in Routing Maintenance (14.13.1) in the cumulative order standard cost. It should match the setting for Include Yield % used normally when running other cost rollup functions.

For example, if there is a yield of less than 100% at an operation, this will cause the overall cost to manufacture to increase, since not all the material produced is expected to be good.

If No, then 100% is substituted for the Yield% field.

**Zero Balance WIP.** This field determines how queue quantities at non-milestone operations are affected when production is reported at subsequent operations. This setting affects:

- Quantities processed in Backflush Transaction (18.22.13)
- Subcontract shipper issues in Sub Shipper Issue (18.22.5.11)
- Receipts from subcontract shippers or purchase orders using PO Shipper Receipt (5.5.5.11) or Purchase Order Receipts (5.13.1)

When Zero Balance WIP is Yes, the system does the following after transferring the item quantity processed, issued, or received from the input queue of the reporting operation and, when needed, the queues of previous non-milestone operations:

- Moves any leftover quantities from previous non-milestone operation queues to the input queue of the non-milestone operation that directly follows the previous milestone operation.
- Sets all other queue quantities to zero for previous non-milestone operations up to the preceding milestone operation.

When Zero Balance WIP is No, leftover quantities remain in non-milestone operation queues until they are moved to subsequent operation queues or manually deleted using WIP Adjust Transaction (18.22.21).

For more information, see “Milestone and Non-Milestone Operations” on page 125.

**Reason Code Criticality.** Specify the system response when an invalid reason code is entered while recording repetitive backflush transactions.

W (Warning): The system displays a warning message and pauses; the system accepts the value when you press any key. This is the default value.

**C (Critical):** The system displays an error message and prompts you to continue. If you choose No, the system returns to the Reason field so you can modify it. If you choose Yes, the system accepts the value.

**Allow Zero Run Rate.** Specify whether item-level records defined in Production Line Maintenance can include a 0 (zero) value in the Units/Hour field.

**No (default):** The item Units/Hour defaults from the production-line run rate. The system always uses the item run rate when calculating schedules for the item. Although you can change the default, you cannot set it to 0.

**Yes:** The item Units/Hour defaults to 0. Unless you change it, the system uses the production line run rate when scheduling the item. Otherwise, it uses the specified non-zero item-level value.

Set the field to Yes to define a global run rate for all items on each production line. In Production Line Maintenance, you can then specify a Units/Hour value at the production-line level and leave all or most item-level fields set to 0. If individual items are exceptions, you can define item-specific run rates just for them.

## Setting Up Production Lines

A production line is defined at a site by specifying the hourly production rate for items produced on that line during a normal shift. One or more items can be made on the same production line, and the same item can be produced on several production lines, all at the same or at different production rates. Optionally, orders for an item can be allocated to several different production lines.

**Fig. 8.3**  
Production Line Maintenance (18.22.1.1)

The screenshot shows the 'Production Line Maintenance' form for 'Production Line: 1000' at 'Site: 10000'. The form includes the following fields and values:

- Description:** Repetitive Production Li
- Units/Hour:** 100.00
- Run Size Enabled:**
- Number of Lines:** 1.0
- Duration Buffer (D H:M:S):** 1 | 04:00:00
- Setup Time (D H:M:S):** 2 | 00:00:00
- Auto Firm:**
- Scheduler ID:** [Searchable field]
- Time Period:** Horizon End: DAY
- Period Number:** 5
- Calculate Date:** 2/13/2011

**Production Line and Site.** Enter the name or code for the production line; then, enter the site for the production line.

**Description.** Optionally, enter a description of the production line.

**Units/Hour.** Enter the standard production rate on this line. The production rate for an item on a production line is equal to that of the operation with the lowest production rate. A production line is no faster than its slowest operation.

*Run Size Enabled.* Enter Yes to enable a link between the run crew size and the run rate. The default is Yes. When Yes, any modification to the run crew size on the production order causes the system to calculate the run crew productivity value and subsequently the required capacity and project duration values for the order. The field exists only at the production line header level.

*Number of Lines.* Enter the number of lines/machines the system uses to process the production order. The default is 1. The system uses it to calculate the production order duration by dividing the production run time by the number of lines/machines the production line represents. Changes to this field cause the system to recalculate duration hours and duration days.

*Duration Buffer (D, H, M, S).* Enter the number of days in the first blank, then the number of hours, minutes, and seconds in the second blank for the duration buffer. Changes to this field cause the system to recalculate duration hours and duration days. You can use this field to add miscellaneous time required to a production order. This field is read at the production line header level.

*Setup (D, H, M, S).* Enter the number of days in the first blank, then the number of hours, minutes, and seconds in the second blank required to set up the production line for this item. The default is 0 (zero). This field exists at the header and detail levels. The header value defaults to the detail level.

*Auto-Firm.* Specify Yes to have the system automatically firm orders scheduled on this production line using Auto Firm Planned Orders (22.20.2). Auto Firm Planned Orders firms planned orders for either production lines or work centers for a specific horizon or a range of dates.

If you use the .NET UI-only Planning and Scheduling Workbenches, you must set this field to Yes if you schedule for production lines and intend to firm planned orders in the workbenches. You must set the same-named field to Yes in Work Center Maintenance if you intend to firm planned orders for work centers using the workbenches. If Auto Firm is set to No, the system does not firm planned orders.

*Last Auto Firm.* Enter a date of the last auto-firm by selecting a date from the calendars that display when you click the drop-down icon in the .NET UI. You can see the date of the last auto-firm in work center and production line browses in QAD EE.

*Scheduler ID.* Enter a valid identification for the scheduler who typically schedules this production line.

*Horizon End.* Specify either Day, Week, or Month as the horizon end for this work center. This field is applicable only when Planning and Scheduling Workbenches are enabled in Site Maintenance.

Work centers display as resources within the Planning and Scheduling Workbench, which is a .NET UI only scheduling tool for both master schedules and production schedules. The workbench depicts the scheduling or sequencing horizon, depending on your order type and which schedule (master or production) with which you work in the workbench. You can change the future and history horizon within the workbench; however, the date you set here depicts the increment for the horizon end.

**Period Number.** Specify the number of periods to use for the scheduling horizon for this work center. This field is applicable only when Planning and Scheduling Workbenches are enabled in Site Maintenance.

Work centers display as resources within the Planning and Scheduling Workbench, which is a .NET UI only scheduling tool for both master schedules and production schedules. The workbench depicts the scheduling or sequencing horizon, depending on your order type and which schedule (master or production) with which you work in the workbench. You can change the future and history horizon within the workbench; however, the period number you set here depicts the number of periods for the horizon.

**Calculate Date.** The calculate date is read-only. The system calculates the date from period and period number, so if you set Horizon End to Day and Period to 5, the Calculate Date is 5 days starting with today. If you set Horizon End to Week and Period to 4, then the Calculate Date is 4 weeks from now including today.

## Items Frame

Use the Items frame to specify attributes and options for a specific item that you manufacture on the production line. The units/hours, number of lines, and setup are display-only and default from the production line setup.

**Fig. 8.4**  
Production Line Maintenance, Items Frame

The screenshot shows the 'Items' frame in a software application. It contains the following fields and values:

- Item Number: WLT18-P1
- Start Date: 6/27/2001
- Units/Hour: 100.00
- Number of Lines: 1.0
- Setup (D:H:M:S): 0 00:00:00
- Primary Line:
- Setup Crew: Size: 0
- Run Crew: Size: 1
- BOM Code: (empty)
- Tool ID: (empty)
- Run Sequence 1: 2
- Comments:

**Primary Line.** Specify whether this item is produced on one or multiple lines.

**Yes:** 100% of the item's production occurs on this line. If you assign a primary line for an item that already has one, the system displays a warning message and the item's previous primary line is reset to No.

**No:** An item's production can occur on multiple lines. To allocate item production percentages to different lines, use Line Allocation Maintenance (18.22.1.11) to set the percent of an item's production for each line; see "Setting Up Line Allocations" on page 122.

**Setup Crew/Size.** Specify a code that identifies the crew that typically sets up the production line for this item; then, specify the number of people in the crew. No scheduling or cost calculations use setup and run crew. This field displays on reports and inquiries.

**Run Crew/Size.** Specify a code that identifies the crew that typically runs the production line for this item; then, specify the number of people in the crew. No scheduling or cost calculations use setup and run crew. This field displays on reports and inquiries.

*BOM Code/Routing.* Enter a valid BOM code and routing for the item.

*Tool ID.* Enter a valid code for the tool that the run crew typically uses for this item to be produced on this production line.

*Run Sequence 1/2.* Enter the code for the item's primary run sequence. A value is typically specified only for items that are line manufactured (Pur/Mfg code is L).

You can use run sequences to schedule items on production lines when approving MRP planned orders for line manufacture. When Sort by Run Sequence is Yes in Planned Repetitive Sched Approve, planned orders for all items produced on a given production line are scheduled by due date, primary run sequence, secondary run sequence, then item number.

See “Approving Planned Line Orders” on page 283.

After you enter a primary run sequence, enter a secondary run sequence in the 2 field. See “Run Sequences” on page 272.

## Setting Up Line Allocations

Within a supply site, items can be produced on one or more production lines. The line allocation specifies how production is distributed among multiple lines.

To set up production line allocations, use Line Allocation Maintenance (18.22.1.11). Set up line allocations for items that can be produced on multiple production lines within a site. The line percentages must total 100%.

**Fig. 8.5**  
Line Allocation Maintenance (18.22.1.11)

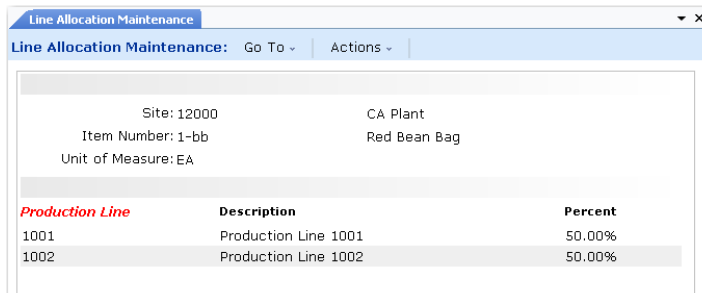

<i>Production Line</i>	<i>Description</i>	<i>Percent</i>
1001	Production Line 1001	50.00%
1002	Production Line 1002	50.00%

Use Line Allocation Inquiry (18.22.1.12) to view line allocations by site and item number.

## Setting Up Shifts

Use Shift Maintenance (18.22.1.22) to define the normal hours and production rate factor for each shift during a day. You can also define any exceptions to that normal pattern.

Set up shifts for a site or for a production line at a site. You can define up to four shifts for a day of the week. A working day should have at least one shift with some number of hours greater than zero and a rate adjustment factor also greater than zero.

**Fig. 8.6**  
Shift Maintenance (18.22.1.22)

The screenshot shows a window titled "Shift Maintenance" with a menu bar containing "Go To" and "Actions". The main content area displays the following information:

- Site: T100
- Production Line: TT
- Shifts: Sunday, Monday, Tuesday, Wednesday, Thursday, Friday, Saturday
- Modify: A column of checkboxes corresponding to the days above.

Below this is a section titled "Monday Shifts" containing a table with the following columns: Shift, Start Time, Hours, Pattern, and Productivity.

Shift	Start Time	Hours	Pattern	Productivity
	08:00	8.0		100.00%
	00:00	0.0		100.00%
	00:00	0.0		100.00%
	00:00	0.0		100.00%

The system rates shift capacity as:

$$\text{Shift Capacity} = \text{Production Rate} * \text{Hours} * \text{Productivity}$$

The hours per shift is the number of hours the shift is capable of producing, rather than the total number of working hours for the shift. Shifts can overlap—so the total number of hours for all shifts can exceed 24 hours.

When a shift is more or less productive than a normal shift, enter an adjustment factor in Productivity.

**Note** This Productivity field has no connection to productivity measures elsewhere in the system.

**Example** A production line has three shifts, and the third shift has only 20% of the employees of the first two shifts. Enter a shift adjustment factor of 20% for that shift.

If the production rate is 100 units per hour, a shift is capable of production for seven hours, and the productivity factor is 100.00%, then its capacity is 700 units per shift. If a second shift has a productivity factor of 50%, then its capacity is 350 units.

The hours worked by a particular shift can change because of holidays, planned shutdowns, or periods with planned overtime. Manage exceptions by adding reference hours to shifts by effective date, in the same way you modify the shop calendar.

**Example** A shutdown is planned for shifts 2 and 3, which normally work seven hours a day. Add -7 hours to those shifts for the affected date range. If overtime is planned for shift 4, then specify additional hours for that shift.

Unlike with the shop calendar, you can add shifts that do not fall on normal working days.

Use Shift Report (18.22.1.23) to see active shift status, exception dates, and shift hour.

**Note** An enhanced version of Shift Report is available at menu 18.22.1.47 for .NET UI users only.

## Setting Up Changeover Times

Define changeover times for a production line in Line Changeover Maintenance (18.22.1.6). For the system to work correctly, you should define changeover times between each pair of items. For instance, on a line where red, green, and gray items are manufactured, the changeover time can vary depending on whether red is being switched to green or to gray.

**Example** If a line manufactures three items—A, B, and C—define changeover times for each of the following.

From	To
A	B
B	A
A	C
C	A
B	C
C	A

A large number of changeover times might be more effectively managed outside of the system using spreadsheet software. Use the CIM interface programs to load the data into Line Changeover Maintenance.

See *User Guide: QAD System Administration* for details on CIM.

## Setting Up Routings and Operations

Items on a repetitive schedule must have a routing. The operations of a routing are used to backflush components and receive completed products into inventory. When you define a routing, you do not have to specify every operation performed on a product. The manufacturing lead time, the length and number of operations, and capacity planning at work center operations must all be considered. Tracking, measuring, and accounting for labor by work center and operation are also factors to consider when specifying a routing.

See “Routings” on page 25 for more details.

In some cases, it is appropriate to set up a routing with a single operation used for backflushing and receiving material.

- Product lead times are short—less than two or three days.
- Capacity is planned by production line.
- Labor is collected and reported in aggregates, such as by department or production line.

The routing operations for an item must be integrated with the item’s product structure for components to be backflushed. All components backflushed from inventory must reference a routing operation. However, all components do not have to refer to the same operation number. With long lead times, different components can be backflushed when different operations are completed.

A number of fields in Routing Maintenance have special significance for repetitive processing.

**Fig. 8.7**  
Routing Maintenance (14.13.1)

The screenshot shows the 'Routing Maintenance' window with the following fields and values:

- Routing Code: 1001
- Operation: 0
- Standard Operation:
- Work Center: 100-01
- Machine:
- Description:
- Machines per Operation: 2
- Overlap Units: 0
- Queue Time: 2.0
- Wait Time: 1.0
- Setup Time: 0.0
- Start Date:
- End Date:
- Assembly:
- Milestone Operation:
- Subcontract LT: 0
- Setup Crew: 2.00
- Run Crew: 5.00
- Tool Code:
- WIP Item: 100A-01
- Move Next Operation:
- Auto Labor Report:
- Yield Percent: 100.00%

Repetitive reporting typically uses milestone operations.

Determines how labor is reported.

### Milestone and Non-Milestone Operations

Milestone operations are routing operations where production counts are recorded. Milestone operations are normally used to report all labor and completions—the last operation is always treated as a milestone. However, you can also use non-milestone operations to report scrap, rejects, rework, or discrepant labor. In this case, you create WIP balances at non-milestones. This allows for more accurate tracking of WIP costs and quantities.

Normally, however, non-milestones are maintained at zero inventory. This can be done automatically by the system or manually, based on the setting of Zero Balance WIP in Repetitive Control (18.22.24).

When Zero Balance WIP is Yes, and you report a processed quantity or a subcontract issue or receipt at any repetitive operation, the system moves any quantities remaining at previous non-milestone operations to the input queue of the non-milestone operation that directly follows the closest preceding milestone operation.

See “Zero Balance WIP” on page 118.

**Example** Operation 10 is a milestone operation and operations 20 and 30 are non-milestones. You report a quantity complete at the next operation, 40. At this time, if an open quantity remains at operation 30, the system moves it into the input queue of operation 20 and the quantity at operation 30 is set to 0 (zero).

When Zero Balance WIP is No, the system does not automatically move quantities out of non-milestone operation queues when you report at subsequent operations. Rather, leftover quantities remain at these operations until you move them out or delete them manually using WIP Adjust Transaction (18.22.21).

### Automatic Labor Reporting

The Auto Labor Report field determines if standard labor is reported automatically by Backflush Transaction (18.22.13).

When Yes, Backflush Transaction automatically reports the standard number of run hours for the quantity processed. Any hours specified directly are considered as additional to the standard. Negative numbers are subtracted from the standard. Backflush Transaction also automatically reports standard hours for each prior non-milestone operation that also has this field set to Yes.

Set this field to No if you do not want to generate labor reporting automatically. In this case, you should report labor explicitly in either the Backflush Transaction or the Run Labor Transaction (18.22.14).

In either case, all setup labor must be reported using the Setup Labor Transaction (18.22.15).

### Subcontract Routings

The way the routing is defined affects subcontracting for repetitive and advanced repetitive operations, including subcontract lead time and subcontract cost.

See “Managing Subcontracting” on page 148 for more details.

### Setting Up Locations

The locations used to backflush inventory vary depending on the number of production lines and how items are supplied. The flow of inventory to the production line usually follows one of two patterns:

- Inventory is received from a supplier or WIP into a central storage location, then transferred from storage to the production line as needed.
- Inventory is received directly from a supplier or WIP to the production line where it is consumed.

In the first, there is a primary stocking location and one or more locations where the item is eventually consumed. In the second, there may be a single stocking location on the production line.

**Note** An item’s primary stocking location is defined in Item Data Maintenance (1.4.3).

A production line location, instead of the primary stocking location, can be set up to backflush material. To do this, set up an inventory location for the production line and give it a location code that is the same as the work center code for the backflush operation.

## Simulating Schedules in the Workbench

You can use a single repetitive schedule for an item that is manufactured on a single production line with a known rate of production. However, consider using Line Schedule Workbench (18.22.1.10) to create simulated schedules when:

- Many different items are produced on a single line.
- Several different lines produce the same item.
- The production rate of a line varies.

You can use Line Schedule Workbench to:

- Create a simulated repetitive schedule (line schedule) for a specific production line and site combination.

- Have the system automatically modify line schedules based on the capacity constraints of the specified production line.

In addition, Line Schedule Workbench lets you update or create repetitive schedules from MRP planned orders. When planned orders for line-manufactured items are approved, these orders are added to the item's line schedule. The sequence in which orders are added to a schedule can be controlled using the Sort by Run Sequence field in Planned Repetitive Sched Approve (23.8). You can review and modify sequences, quantities, and dates as needed.

Simulation usually takes place during production planning. The planner creates a line schedule that meets production requirements and balances line utilization and then uses it to generate repetitive production schedules.

See “Approving Planned Line Orders” on page 283.

The line schedules you create in the workbench are simulations only and are not considered by MRP or other planning functions until you copy them to repetitive schedules using Repetitive Schedule Update (18.22.1.18).

See “Updating a Repetitive Schedule from a Line Schedule” on page 129.

To create a simulated schedule, specify the production line, site, and start date. Set the Multiple field to a positive number to limit the quantity for each line sequence record to multiples of that number.

Then, enter production quantities and dates into the workbench or review and modify existing sequence records as needed. Each entry has a sequence (priority) number. By manipulating the sequence number, you can change the order in which items will be manufactured. Use Insert to create a new line sequence record in the workbench.

**Fig. 8.8**  
Line Schedule Workbench (18.22.1.10)

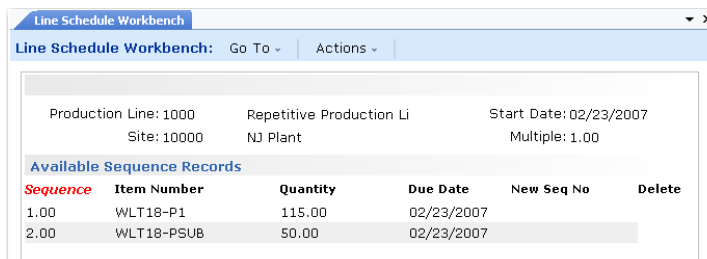

The screenshot shows the 'Line Schedule Workbench' window. At the top, it displays 'Line Schedule Workbench: Go To Actions'. Below this, there are three fields: 'Production Line: 1000', 'Repetitive Production Li', and 'Start Date: 02/23/2007'. Underneath, it shows 'Site: 10000', 'NJ Plant', and 'Multiple: 1.00'. A section titled 'Available Sequence Records' contains a table with the following data:

Sequence	Item Number	Quantity	Due Date	New Seq No	Delete
1.00	WLT18-P1	115.00	02/23/2007		
2.00	WLT18-PSUB	50.00	02/23/2007		

## Determining Order Multiples

The Multiple field controls the minimum divisible schedule quantity for a workbench session. The default setting of 1.00 lets you create schedules with whole integer quantities only. When set to zero, Line Schedule Workbench attempts to use all available time to manufacture scheduled quantities. As a result, it will schedule decimal quantities if necessary.

You can set Multiple to any other quantity, as needed. This is useful if you plan orders in single units and schedule in multiples. Or, you can set Multiple to any meaningful decimal quantity such as 0.5. Then, you can enter schedule quantities in units of 0.5. A negative value is not allowed.

You cannot change the value of Multiple on existing schedules if non-divisible quantities would result.

## Sequence Numbers and Due Dates

The workbench uses sequence numbers and due dates to resolve scheduling conflicts. When two production runs are scheduled for the same due date but there is only enough capacity for one, the system gives priority to the one with the lower sequence number. After planning the first production run and making adjustments for changeover time, it plans output for the second production run. Because the system uses finite loading, the first scheduled due date for the second production run may be later than the date originally entered.

Whenever you create or modify a sequence record, the system automatically reschedules the production quantities and dates and reassigns new sequence numbers. To insert a new production quantity between two existing quantities, enter a sequence number with a value between the two and a due date equal to the earlier of the two dates.

## Production Quantities

Add production quantities to the workbench directly or select from MRP planned orders. The system converts the quantities on the planned orders to schedule quantities and deletes the selected orders.

As a general rule, production quantities should be directly related to the period used for scheduling production. If production is scheduled by day, the production quantity should not be sufficient to cover an entire week. This becomes important when a production line is scheduled to process different products during a given week.

If MRP uses a POQ order policy and the period is a week or longer, the production quantities recommended by MRP planned orders might cover a week. In this case, separate the quantity recommended by MRP into smaller quantities.

One day is the shortest period you can use to schedule production. You can schedule multiple items each day, but if scheduled production is by shift, then you must summarize production into daily quantities before entering it into the workbench.

## Scheduling and Lead Times

In some situations, different products manufactured on a line have significantly different lead times. Even if flow rates are similar through most of the line, some products might spend more or less time at an operation—for example, products that are burned-in, dried, aged, or cured.

When a line is changed over from processing one product to another with a significantly longer lead time, the line's output is interrupted by the changeover time plus the new lead time. This might not be important if you are manually determining the due date for expected output from a line. But if the system encounters a scheduling conflict and reschedules due dates, these dates will not take into account the new lead time.

There are two ways to avoid this:

- Assign due dates manually and then monitor the line schedule to see if any due dates following a changeover have been automatically rescheduled.
- Increase the changeover time to reflect the increased lead time between two products. This way the changeover time reflects the total time a line is disrupted between model changes.

## Deleting Sequence Records

Delete records from the workbench in two ways:

- Select one or more records for deletion and choose Delete.
- Reverse the original production quantity by entering a negative value. For example, enter a quantity of –2000 for a production quantity of 2000. The system deletes all of the scheduled quantities and dates created by that entry.

## Reviewing Line Schedules

Use Line Utilization Report (18.22.1.15) to review the results generated by the workbench. This report provides information for evaluating the load placed by a line schedule on a production line if it replaced the existing repetitive schedule. It also shows the changeover load between shifts, when appropriate.

## Creating Repetitive Schedules

A repetitive schedule is a statement of planned output for a production line for one day. It consists of a list of scheduled quantities and due dates. A repetitive schedule controls the same activities as a work order. However, because it is used for continuous process manufacturing, it issues components from inventory by backflushing. This method deducts the required quantities from inventory when order quantities are reported as complete.

If you used Line Schedule Workbench (18.22.1.10) or Planned Repetitive Sched Approve (23.8) to create a line schedule, use Repetitive Schedule Update (18.22.1.18) to turn the line schedule into a repetitive schedule. Otherwise, create repetitive schedules using Schedule Maintenance (18.22.2.1).

See “Simulating Schedules in the Workbench” on page 126.

## Updating a Repetitive Schedule from a Line Schedule

Once you are satisfied with a line schedule in the workbench, use Repetitive Schedule Update (18.22.1.18) to generate the repetitive schedule or update an existing one.

**Fig. 8.9**  
Repetitive Schedule Update (18.22.1.18)

Site: 10000	To: 10000
Production Line: 1000	To: 1000
Item Number: 100A	To:
Due Date: 02/23/2007	To:
Update: <input checked="" type="checkbox"/>	
Delete Line Schedule: <input type="checkbox"/>	

Output: WinPrint  
Batch ID:

You can delete the line schedule as you update, or retain it. Typically, you retain the line schedule, since you can continuously maintain it by adding new MRP orders. However, you can use this function to delete an unneeded simulation by setting Update Repetitive to No and Delete Line Schedule to Yes.

**Example** A four-week repetitive schedule for an item on a production line needs an additional week added every week. Use the workbench to schedule the new week, and Repetitive Schedule Update to update the schedule.

After updating repetitive schedules, run MRP to synchronize planned orders with the schedule changes.

## Schedule Maintenance

Use Schedule Maintenance (18.22.2.1) to enter or maintain daily schedules for each production line at a site. If the production line has multiple shifts, the schedule represents the total for all shifts. If there are no production lines at the site, you can enter a schedule for the whole site.

**Fig. 8.10**  
Schedule Maintenance (18.22.2.1)

Day	Due Date	Scheduled	Routing	BOM Code
Monday:	06/25/2007	8.0	MDR100	1-BB
Tuesday:	06/26/2007	8.0	MDR100	1-BB
Wednesday:	06/27/2007	8.0	MDR100	1-BB
Thursday:	06/28/2007	8.0	MDR100	1-BB
Friday:	06/29/2007	8.0	MDR100	1-BB
Saturday:	06/30/2007	0.0	MDR100	1-BB
Sunday:	07/01/2007	0.0	MDR100	
Total:		40.0		

The bill of material (BOM) and routing for an item on a repetitive schedule default from Item Master Maintenance (1.4.1) or Item-Site Planning Maintenance (1.4.17). You can specify valid alternates, but you cannot combine different BOMs and routings on one order.

## Reviewing Repetitive Schedules

Use Production Line Schedule Inquiry (18.22.2.13) to review the production schedule for a selected production line and day.

Use Production Line Schedule Report (18.22.2.15) to review the production schedule for a range of production lines and dates.

## Exploding Repetitive Schedules

Once you establish a schedule, you must explode it using Schedule Explosion (18.22.2.4). The explosion creates the material and work center operation requirements necessary to support the schedule.

Until exploded, changes to the schedule are not reflected in component demand or work center load. MRP reports for the components or CRP reports for the affected work centers do not reflect the current repetitive schedule until it is exploded.

The schedule explodes automatically when MRP plans the item and site or when you run Schedule Explosion. An exploded schedule creates scheduled work orders for each day of production. Review these work orders in the Work Orders module. They have a type of S (scheduled).

Run Repetitive Picklist Calculation (18.22.3.1) to see if shortages at work centers need to be corrected.

## Using Repetitive Picklists

In most repetitive operations, issues are managed solely by backflushing. However, in many operations, you also need to manage the movement of inventory to the point where it is used. In environments where inventory is stored on the production line, the repetitive picklist lets you easily replenish the line's work centers.

Use repetitive picklists to move inventory from stocking locations to a work center. To use this method, you must define work centers as inventory locations.

Each repetitive schedule creates inventory requirements at the work centers in its routing. When you run Repetitive Picklist Calculation (18.22.3.1), the system:

- Determines the available inventory and requirements at each work center for the specified range of parent items
- Determines where shortages exist
- Allocates inventory to meet shortages
- Creates a picklist for each work center shortage

**Fig. 8.11**  
Picklist Processing Flow

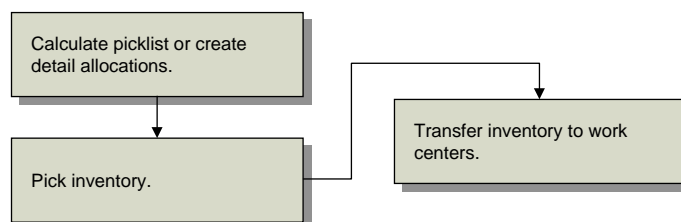

The system creates a picklist if there is a shortage and inventory is available to be picked. When you print the picklist, the inventory is picked. Use Repetitive Picklist Transfer (18.22.3.6) to transfer the inventory from its current inventory location to the work center. This move is a location transfer, not an issue to WIP, so there are no GL transactions until the inventory is backflushed.

**Example** Item A is installed in four different end items at work center OPS. The work center has 900 of Item A on location. For the next week, the repetitive schedules for these items have a total requirement of 1,000. The repetitive picklist calculation will show a shortage of 100 of Item A at OPS and detail allocates 100 at the inventory location. When the picklist is printed, the 100 will be shown as picked, and 100 will be moved to location OPS when the transfer is run. The inventory will not be issued until labor is reported for each operation.

**Note** To use picklists, you must set up a location with the same ID as the work center.

## Calculate the Picklist

Calculate the picklist and create detail allocations using Repetitive Picklist Calculation (18.22.3.1). The calculation considers component requirements from the exploded repetitive schedules that match the sites, items, work centers, and production dates specified.

**Fig. 8.12**  
Repetitive Picklist Calculation (18.22.3.1)

Repetitive Picklist Calculation

Repetitive Picklist Calculation: Go To - Actions -

Site: 10000 To: 10000  
 Parent Item: To:  
 Component Item: To:  
 Work Center: 100-01 To: 100-01  
 Production Date: 02/23/2007 To: 02/27/2007  
 Release Date: To:

Use Work Center Inventory:   
 Use Order Multiple:   
 Detail Requirements:   
 Picklist Number: PL1  
 Delete When Done:

Output: WinPrint  
 Batch ID:

For a new schedule creating requirements at a work center with no shortages, Repetitive Picklist Calculation uses the following equation.

$$\text{Shortage at Work Center} = \text{New Requirements} - \text{Net Available}$$

Where net available equals:

$$\text{Actual OH} - \text{Qty Alloc} - \text{Qty Req by Other Scheds} + \text{Untransferred Picked}$$

The Net Available is the material available for these requirements at the work center, consisting of the material already there (Actual OH) and the material to be transferred (Untransferred Picked) minus the existing requirements. The existing requirements consist of the Qty Req by Other Scheds and the quantity allocated at that work center to work orders or sales orders (Qty Alloc).

**Note** When Use Work Center Inventory is No, on-hand inventory and quantities from untransferred picklists are not considered in the calculation.

As the equation shows, the picklist supplies material for the work center, not individual schedules. You can ensure that picklists supply individual schedules by running the picklist calculation immediately after exploding each new schedule. The picklist calculation already considers all existing picklists, so the new picklist will only meet the new requirements.

## Choosing Options

Repetitive Picklist Calculation offers several options to control the picklist calculation.

*Use Work Center Inventory.* When Yes, the system counts inventory in a work center, as well as quantities from untransferred picklists, as inventory.

*Use Order Multiple.* When Yes, the system determines the number of items to be transferred (quantity required) and then rounds that number up based on the order multiple defined in Item Master Maintenance (1.4.1), Item Planning Maintenance (1.4.7), or Item-Site Planning Maintenance (1.4.17).

When No, the exact quantity required prints on the picklist and no rounding is applied by the system. Set this field to No when you are using lean manufacturing techniques and do not want any extra items on the shop floor.

*Detail Requirements.* When Yes, the system prints all repetitive schedules generating requirements for a component, including the quantity required, parent item, due and start dates, machine, and operation.

*Delete When Done.* When Yes, the picklist is automatically deleted after the calculation. Use this option to review shortages without actually allocating inventory. The Next Picklist field in Repetitive Control (18.22.24) is not incremented.

### Troubleshooting Problems

If problems occur with the picklist calculation, remember the following:

- A location must be created with the same name as the work center.
- The calculation does not create a picklist if there is no inventory to detail allocate. You cannot allocate negative quantities. The system does not warn you if inventory is insufficient to meet the requirements—it just does not create a picklist.
- The system does not create a picklist if there is sufficient inventory at the work center.
- Detail allocations are not associated with specific orders, so no order IDs are shown in the allocated inventory inquiry.
- Depending on the setting of Use Work Center Inventory in Repetitive Picklist Calculation, the system may use untransferred picklists as sources of supply. To recalculate total requirements at a work center, delete all untransferred picklists. A picklist remains open until deleted or inventory is transferred, even if the schedule changes.
- The picklist calculation blows through phantoms. There is no phantom use-up logic.
- The picklist does not calculate requirements by shift.
- Since the calculation is based on requirements from an exploded repetitive schedule, it is not affected by changes in structures or routings.
- You can further control the quantities on a picklist using the item-site planning parameters Minimum Order and Maximum Order.

### Print the Picklist

Print the picklist in Repetitive Picklist Print (18.22.3.5). Printing changes the status of the detail-allocated inventory to picked. The picking logic is the same logic used elsewhere in the system, set in Inventory Control (3.24). You can reprint the picklist without affecting inventory status.

Use Repetitive Picklist Undo (18.22.3.8) to cancel a picklist and reprint it later. It changes the inventory status back to detail allocated.

When a picklist exists, it is considered supply by later picklist calculations. If you want to start over, you must delete the outstanding picklists with Repetitive Picklist Delete (18.22.3.9). Deleting reverses all effects of running any picklist function. If the inventory is picked or allocated, it is returned to unallocated status.

See *User Guide: QAD Master Data* for information on picking logic.

## Transfer the Inventory

Use Repetitive Picklist Transfer (18.22.3.6) to transfer inventory from the stocking location to the work center. Inventory is transferred, not issued. The new location must exist and must have the same name as the work center. After transferring the inventory, the system deletes the picklist.

Specify the date of the transfer in a pop-up frame after clicking Next on the header. The default is the system date.

**Fig. 8.13**  
Repetitive Picklist Transfer (18.22.3.6)

The screenshot shows the 'Repetitive Picklist Transfer' window. At the top, there are two menus: 'Go To' and 'Actions'. Below these are several input fields: 'Site' with the value '12000', 'Picklist' with 'PL1', 'Sequence' with '2', 'Alloc' with a checked checkbox, and 'Picked' with a checked checkbox. Below the input fields is a table with the following columns: 'Work Ctr', 'Item Number', 'Qty Open', 'Qty Alloc', 'Qty Picked', and 'Qty to Iss'. Below the table, there are several fields for 'Work Center:', 'Item Number:', 'Description:', 'Quantity:', 'Site:', 'Lot/Serial:', 'Reference:', and 'Multi Entry:'. The 'Multi Entry' field has a checked checkbox.

Use the Sequence code to transfer only part of the total if space at the work center is limited.

**Example** If a work center holds 1,000 of an item, but the total requirements are 5,000, one picklist is created allocating 5,000, while the material is picked and transferred in sequences of 1,000 (sequence 1 for 1,000, sequence 2 for 1,000, and so on).

Set the maximum order quantity for an item in the Order Multiple field (Ord Mult) in Item Planning Maintenance (1.4.7) or Item-Site Planning Maintenance (1.4.17).

To transfer specified quantities other than the order maximum, set the amount in Order Mult.

**Example** If the stocking unit of an item is liters but the item is delivered to the work center in 500-liter barrels, set an order multiple of 500 to ensure the item is transferred 500 liters at a time.

You can transfer inventory even if a picklist has not been created or printed. Use the Alloc and Picked fields to set the default for your transfers. You can also directly specify inventory to issue.

After issuing inventory, the system records an ISS-TR transaction and a RCT-TR transaction in transaction history.

## Managing Cumulative Orders

The system keeps a running total for each combination of items, sites, production lines, product structures, and routings using a cumulative order. The cumulative order tracks work-in-process (WIP) costs and quantities for repetitive production. A cumulative order is created for a profile that defines the site, item number, production line, routing code, BOM/formula code for the order, and start and end effective dates.

Cumulative orders can be created three ways:

- Automatically by the system when you execute a repetitive transaction (18.22.13 –18.22.21)
- One at a time with Cumulative Order Maintenance (18.22.6)
- In a batch with Cumulative Order Create (18.22.11)

When a cumulative order is created, a cost rollout establishes the cumulative order cost. Cumulative orders have an assigned ID number, but no order number.

Repetitive transactions create a cumulative order when they cannot find one with the same profile (site, item, production line, routing, BOM or formula code) where the effective date range includes the effective date of the repetitive transaction. The system sets effective dates on new cumulative orders using the parameters defined in Repetitive Control.

When you run an Advanced Repetitive transaction or create a cumulative ID with an Advanced Repetitive maintenance program, the system:

- Searches for discrete or scheduled subcontract purchase orders associated with subcontract routing operations. See “Managing Subcontracting” on page 148.
- Automatically updates blank ID fields on subcontract purchase order lines with the newly created cumulative order ID.
- Automatically updates blank subcontract operation fields with the subcontract operation for the item on the purchase order.
- Replaces any existing, expired cumulative order IDs with an open cumulative order ID on subcontract purchase orders.

For scheduled orders, the system first checks the effective dates for the scheduled order line. If the effective dates indicate that the scheduled order line expired, the system does not update the line with the new open cumulative order ID.

When standard costing is used at the site on the cumulative order, recording repetitive transactions generates rate variances and creates GL entries for them. Usage and method variances are accumulated and posted when you run one of the following:

- Post Accumulated Usage Variances (18.22.9) generates GL entries for usage and method change variances accumulated since this function was last run.
- Cumulative Order Close (18.22.10) closes cumulative orders and creates GL entries for usage and method variances accumulated since Post Accumulated Usage Variances was last run. You can transfer WIP balances to another cumulative order or post them to Method Change Variance.

Post Accumulated Usage Variances and Cumulative Order Close can be run in report-only mode if needed.

All rate and usage variances are measured against the cumulative order cost. GL scrap entries are not created until you run either Post Accumulated Usage Variances or Cumulative Order Close.

Use Cumulative Order Browse (18.22.7) or Cumulative Order Report (18.22.8) to review cumulative order information including start and end effective dates and status.

## Cumulative Order Create

Use Cumulative Order Create (18.22.11) to create new cumulative orders in advance in a batch-oriented setting. This prevents the system from having to create them during repetitive transactions, and ensures a better response time for items with many components.

To use this function, orders must already exist in the system. The new order is based on the old, with a different effective date. For each cumulative order selected, the system checks to see if a cumulative order exists with an effective date range that includes the day after the entered End Effective date. A new cumulative order is created if none exists. The Start and End Effective dates of the new cumulative order are set based on the End Eff Default Method in Repetitive Control.

See “End Eff Default Method” on page 117.

A cumulative order is created for a profile that defines the site, item number, production line, routing code, and BOM/formula code for the order, and start and end effective dates. Two orders that have the same profile cannot have overlapping effective dates. When a cumulative order is created:

- The work order ID is automatically assigned.
- The work order number is blank.
- The work order type is C.
- The work order status is R.
- Blank cumulative order ID and operation fields on subcontract scheduled orders or discrete purchase orders are updated with the new ID and the subcontract operation from the routing. See “Managing Subcontracting” on page 148.

## Cumulative Order Close

Use Cumulative Order Close (18.22.10) to select and close open cumulative orders according to various criteria. You can optionally create successive cumulative orders and transfer WIP queue balances to them. Cumulative orders must have an end effective date on or before the End Effective value you enter. Orders with a blank end effective date will not be selected.

**Note** To close orders with blank end effective dates, first enter an end effective date using Cumulative Order Maintenance (18.22.6).

Closing a cumulative order performs the same processing as the Post Accumulated Usage Variances transaction. Variances are calculated, posted, and reported. When Transfer WIP is Yes, WIP queue balances are transferred from the closed cumulative orders to new cumulative orders.

To close a cumulative order before its end effective date, use Cumulative Order Maintenance to set the end effective date to yesterday’s date. The system creates a new cumulative order for the balance of the period if the End Eff Default Method is set to 1 or 2 in Repetitive Control (18.22.24).

## Transferring WIP

To transfer WIP values and quantities from closed orders to new cumulative orders, set Transfer WIP to Yes in Cumulative Order Close. The system searches for a cumulative order with the same profile (site, item number, production line, routing, and product structure code) and a start effective date equal to the day after the end effective date specified in the selection criteria.

**Table 8.1**  
Transferring WIP

If	Then
An open cumulative order exists,	the system receives the WIP quantities of the cumulative order being closed.
A closed cumulative order exists,	WIP quantities do not transfer.
There is no cumulative order,	the system creates a new one to which WIP is transferred.

## Processing Steps

Cumulative Order Close does the following for each operation in the cumulative orders selected for processing:

- 1 Posts the value of the WIP queue inventory to the appropriate cost account.
  - When Transfer WIP is Yes, this is the WIP Transfer account specified in Advanced Repetitive Accounting Control (36.9.12).
  - When Transfer WIP is No, this is the Method Change Variance account.
- 2 Records the posting event by creating an operation history record of type Close.
- 3 Changes the cumulative order status to Closed.

## Transferring WIP

When Transfer WIP is Yes, the system transfers WIP queue quantities from each cumulative order operation that meets the following conditions:

- The WIP quantity is not zero.
- It has a corresponding operation record in the receiving cumulative order.

The system follows these steps to transfer WIP queue balances from closed cumulative orders to new orders:

- 1 For each operation with a WIP quantity to transfer, the system searches for an operation in the receiving order with the same operation code. If it finds one, it proceeds with the transfer. Otherwise, it ignores that operation and does not transfer the WIP.
 

**Note** For the system to transfer WIP to the first operation in the receiving order, the corresponding operation in the transferring order must also be the first operation, in addition to having the same operation code. Unless both these conditions are met, the system ignores the operation and does not transfer WIP.
- 2 The system transfers the WIP queue quantities from the old cumulative order operations to the output queues in the receiving order operations.

- 3 The system records the transfer by creating an operation history record of type Transfer.
- 4 The system generates the appropriate GL transactions to transfer the WIP value to the new cumulative order.
- 5 When the cost of the WIP queue inventory for an old cumulative order operation differs from the cost at the receiving operation, the system posts the difference to Method Variance.

After these calculations are complete, a residual value may remain in WIP. This is because when the system debits WIP during repetitive reporting transactions, fractional values may remain in WIP due to rounding differences. These residual values accumulate in WIP until the cumulative order is closed. Cumulative Order Close posts the residual WIP value from each closed cumulative order to Method Variance.

You can run Cumulative Order Close in report-only mode as needed.

### Cumulative Order Maintenance

Use Cumulative Order Maintenance (18.22.6) to create new cumulative orders manually or maintain the start and end effective dates on an existing order. You cannot change effective dates so that they overlap those on another cumulative order for the same profile. You can also delete closed cumulative orders.

## Executing Repetitive Transactions

As work is performed, labor and movement of WIP units are reported. You can report these activities using various types of transactions, including downtime, scrap, rework, move, and rejects. There are nine transaction types and several purchase order functions for subcontract activities.

Repetitive transactions affect other areas of the system. As quantities are moved through repetitive operations, inventory transactions are recorded and posted as backflushing occurs. Labor and burden costs are recorded by manual entry or as a result of backflushing.

Transactions generate cost variances and create GL entries. Most transactions generate quantity and cost posting to the cumulative order and associated operation and bill of material (BOM) records.

Transactions affect any one of the three quantity queues associated with routing operations:

- The input queue, which holds quantities from the previous operation
- The output queue, which holds quantities from the current operation that have not been moved to the next operation
- The reject queue, which holds quantities rejected by the current or a subsequent operation

### Shipping Documents

Many countries require that formal shipping documents accompany any movement of goods. If you are using shipping groups, you can record shipping information and generate shipping documents from some repetitive transactions.

When a backflush occurs at a site other than the work order site and the site addresses exist in a shipping group with an inventory movement code that allows ISS-WO, you are prompted for shipper information. This can occur in Backflush Transaction (18.22.13) and Rework Transaction (18.22.17).

Shippers can also be generated when a picklist transfer occurs in Repetitive Picklist Transfer (18.22.3.6) and the addresses associated with the from and to site or location are associated with a shipping group with an inventory movement code that allows ISS-TR.

See the Shipping chapter in *User Guide: QAD Sales* for details.

## Common Transaction Data

All repetitive transactions use common information entered in the first frame. Figure 8.14 shows the first frame of Backflush Transaction (18.22.13).

**Fig. 8.14**  
Transaction Programs— Common Information

The screenshot shows a software window titled "Backflush Transaction" with a menu bar containing "Go To" and "Actions". The form is divided into several sections:

- Employee Information:** Employee: MFS01, Effective: 06/18/2007, Shift: (blank), Site: 10000, WIP Lot Std Rep (blank).
- Item Information:** Item Number: WLT18-P1, Repetitive Production Li (blank), BOM Code: WLT18-P1, ID: 129.
- Operation Information:** Operation: 10, Line: 1000, Routing: WLT18-P1.
- Work Center Information:** Work Center: 10000, Department: 10, Machine: (blank), General # 1.
- Production Data:** Qty Processed: 0.0, Qty Scrapped: 0.0, Qty Rejected: 0.0, Reject To Op: 10, Actual Run Time: 0.0, Earning Code: (blank).
- General Settings:** UM: EA, Reason Code: (blank), Modify Backflush: , Conversion: 1.0000, Multi Entry: , Move Next Op: , Start Time: (blank), Elapsed or Stop Time: (blank).

The Employee field is mandatory. Enter a valid employee set up either in Employee Create (36.1.7.1) or Actual Pay Rate Maintenance (14.13.21). A valid effective date, site, item number, and operation are required. Shift is optional.

If the item number is associated with a production line, you must enter a valid production line in the Line field. Enter Routing and BOM only if you are not using the default. ID is a system-generated cumulative order ID and cannot be modified.

The system uses the values entered in the Effective, Site, Item Number, Operation, (Production) Line, BOM, and Routing fields to locate the appropriate cumulative order.

The selected cumulative order has start and end effective dates that include the transaction effective date. Table 8.2 describes the way a cumulative order is selected, based on the effective date entered.

**Table 8.2**  
How a Cumulative Order is Selected

If	Then
A cumulative order has a blank start effective date, indicating that its effective interval is from the end effective date into the indefinite past,	it will always be selected if the transaction effective date is on or before the end effective date.
A cumulative order has a blank end effective date,	its effective interval is from its start effective date into the indefinite future, and will always be selected if the transaction effective date is on or after the start effective date.

If	Then
A cumulative order has blank start and end effective dates,	the cumulative order will always be selected.
No cumulative order is found matching the above criteria,	one is immediately created. The start and end effective dates are set according to the parameters defined in Repetitive Control.
The dates in the new order overlap with the dates in some other cumulative order,	the dates in the new order are adjusted forward or backward to prevent overlap.

The cumulative order creation process retrieves the routing in effect as of the transaction effective date and copies it to the cumulative order. For each operation in the routing, this process retrieves the product structure in effect as of the transaction effective date and copies it to the cumulative order operation. Any phantoms are blown through.

See “Phantoms” on page 8.

A cost rollup is then performed in the new cumulative order, and the calculated operation costs are recorded by operation in the cumulative order routing. These costs are used for WIP valuation reporting and calculating variances.

The costs are independent of the item cost and routing cost. The Cumulative Order Cost Report (18.22.4.10) displays the operation costs stored in the cumulative order.

## Warning Messages

All transaction programs issue warning messages when one of the following occurs:

- The operation being accessed is a non-milestone operation.
- A transaction would cause a WIP queue for an operation to become negative.

All transaction programs write operation history records to record the transaction events.

## Rate Variances

All transactions consuming resources immediately calculate and post rate variances. These are generated when the standard costs in effect for components or labor at the time of the transaction differ from the resource costs recorded on the cumulative order.

The component costs recorded in a cumulative order are based on the GL standards in effect when the order was created. Labor, burden, and subcontract costs in the cumulative order are based on the routing and work center data in effect when the order was created.

For component material, rate variance is calculated as the difference between the GL standard cost currently in effect and the GL standard cost captured in the cumulative order. This type of variance is rare and typically occurs when the GL standard cost of the component material changes during the life of the cumulative order.

Labor and burden rate variance is calculated in a similar way. When a cumulative order is created, standard labor and burden rates are captured from the routing and work center data in effect. When labor is reported at a cumulative order operation work center, rate variance is calculated as the difference between the actual employee pay rate and the standard rate recorded on the cumulative order.

Subcontract rate variance is the difference between the PO price per unit and the subcontract cost per unit as captured in the cumulative order. This is posted when subcontract items are received from a shipper or PO.

Rate variances are posted only if GL standard costing is in effect for the finished item. They are not posted if GL average costing is in effect.

## Method Change Variances

Method change variance (MCV), when calculated, is posted by the following transactions:

- Cumulative Order Close (18.22.10)
- Backflush Transaction (18.22.13)
- Run Labor Transaction (18.22.14)
- Setup Labor Transaction (18.22.15)
- Rework Transaction (18.22.17)
- Move Transaction (18.22.19)

MCV is calculated as the difference between the final operation cost recorded in the cumulative order and the GL standard cost of the finished material, extended by the quantity being reported. In the backflush and move transactions, MCV can be posted when moving from the output queue of the last operation to finished material inventory.

In the transactions where labor is reported, MCV is also generated when reporting at a work center other than the cumulative order operation work center. MCV is calculated as the difference between the standard labor and burden rates of the work center being reported and the standard labor and burden rates of the cumulative order operation work center, extended by the number of hours reported. This prevents unexpected rate variances from being applied to work centers.

In Cumulative Order Close, MCV can be posted when transferring WIP quantities to new cumulative orders. MCV is calculated as the difference between the operation cost in the former cumulative order operation and the operation cost of the new cumulative order operation, extended by the quantity transferred.

See “Cumulative Order Close” on page 136.

Method change variances are posted only if GL standard costing is in effect for the finished item. They are not posted if GL average costing is in effect.

## Repetitive Transaction Programs

The following sections describe the use and application of various transaction programs on the Advanced Repetitive menu.

## Backflush Transaction

Backflush Transaction (18.22.13) is the primary tool for reporting production line activity and the only transaction that automatically backflushes component inventory. You can report the number of gross units processed, scrapped units, rejected units, and labor hours. Backflush Transaction can be used at both milestone and non-milestone operations. If the transaction is reported at the last operation, you can receive completed items into inventory.

You can backflush components of the current operation and any preceding non-milestone operations. You can also backflush standard labor and burden if the routing record of the reporting operation, or any preceding non-milestone operation, has Auto Labor Report set to Yes.

When you report that you have completed and moved items at the final operation, the quantity is posted as complete at the operation, and is also posted to the repetitive schedule and the related work order. If there are multiple schedules for an item, the system determines the earliest open schedule date and posts the completed quantities from that point forward.

If the system cannot find enough open balances, the operation is posted with the transaction quantity. However, the repetitive schedule and work order record are posted with the open quantity available.

You can modify repetitive schedule completions using Cumulative Completed Maintenance (18.22.2.6). You can view the repetitive schedule completions using either Schedule Inquiry (18.22.2.2) or Operation Schedule Report (18.22.2.5). You can view work order completions using Work Order Browse (16.2).

**Fig. 8.15**  
Backflush Transaction (18.22.13)

The following are fields in the second frame of Backflush Transaction (18.22.13). Work Center, Machine, and Department default from the routing operation and can be overridden.

**Qty Processed.** Shows the quantity processed through the operation. This value includes any quantity entered in the Qty Scrapped and Qty Rejected fields. Entering a value in this field has two effects.

- The input queue quantity is reduced by the amount entered.
- The output queue quantity is increased by the amount entered.

Components for the operation are backflushed by the quantities per unit extended by the quantity processed.

*Qty Scrapped, Reason Code, Multi Entry.* Report scrap quantity along with the processed quantity. Enter up to 10 scrap quantities and reason codes in a separate pop-up.

*Qty Rejected, Reason Code, Multi Entry, Reject To Op.* Report reject quantity along with the processed quantity. Enter up to 10 scrap quantities and reason codes in a separate pop-up. Reject To Op must reference either the current operation or the one that precedes it. The default is the current operation.

*Modify Backflush.* When Yes, the Component Issue frame displays so you can modify the default list of sites, locations, lot and serial numbers, and quantities used for component backflush and finished material receipt.

The component backflush logic considers the product structure in effect on the transaction effective date. If components are added, changed, or removed from the current product structure during the life of a cumulative order and backflush transactions occur, the differences cause material usage variances. Product structure and routing changes can be phased into cumulative orders by setting the cumulative order effective dates to match the product structure and routing effective dates.

*Move Next Op.* When Yes, the Receipt Data frame displays when reporting against the last operation. The Move Next Op field indicates whether the quantity processed—minus rejected and scrapped quantities—is moved to the input queue of the next operation. If the operation being reported is the last operation, the move increases finished goods inventory. This value defaults from the routing operation.

**Note** You cannot add an operation to the routing for an open cumulative order. You must close the cumulative order, make the routing changes, roll up the cost, then open a new cumulative order.

### Run and Setup Labor Transactions

Use these programs to easily report run and setup labor only for non-milestone or milestone operations:

- Use Run Labor Transaction (18.22.14) to report regular labor chargeable against WIP.
- Use Setup Labor Transaction (18.22.15) to enter separate setup times, also charged against WIP.
- Use Down Time Transaction (18.22.20) and Non-Productive Labor Feedback (18.22.22) to report indirect labor. These transactions are not subject to applied burden.

### Reject Transaction

Reject Transaction (18.22.16) has two uses:

- To reject previously backflushed units from an operation's output queue to the same operation's reject queue or to the reject queue of any preceding operation
- To reject units from an operation's input queue and record the reject at the previous operation

Enter up to 10 different reject codes at a time. You cannot report hours, and no backflushing takes place.

Use Backflush Transaction (18.22.13) for most reject reporting. This transaction backflushes the rejected units and records all costs at the operation. When you use this transaction to report rejects at a milestone operation, the quantity must be in the input queue of the current operation or in the input or output queues of prior non-milestone operations.

**Note** If you are rejecting with backflush at a non-milestone operation, the quantity to be rejected must be in the input queue of that non-milestone operation.

### Rework Transaction

When you first report rejected quantities, use the Reject To Op field in Backflush Transaction (18.22.13) or the To Operation field in Reject Transaction (18.22.16) to send the quantity to the operation where rework occurs. In WIP Status Inquiry (18.22.12), the rejected quantities appear as negative numbers in the output queue of the operation where the reject occurred, and as a positive number in the reject queue of the receiving operation.

Reworked units are backflushed at the operation rejecting them. After reworking items, use Rework Transaction (18.22.17) to move the reworked items back into the production line. Use the To Operation and To Queue fields to select the operation and queue, typically one of the following:

- The rejecting operation's output queue
- The input queue of the operation following the rejecting operation

**Note** This method requires an additional Move Transaction (18.22.19).

You can enter rework hours and issue additional components. However, no automatic backflushing takes place. Enter up to 10 reject quantities and reason codes at a time.

### Scrap Transaction

Use Backflush Transaction (18.22.13) for most of your scrap reporting. It backflushes the scrapped units and records all costs at the operation.

Use Scrap Transaction (18.22.18) to scrap or remove quantities from any queue of an operation without backflushing. This transaction is often used to scrap previously rejected units. Enter up to 10 scrap quantities and reason codes at a time.

When scrapping from an operation's input queue, the scrap quantity is first moved back to the prior operation's output queue and then posted as scrap at that operation. This ensures a proper balance in the queues and cumulative quantities (as seen in the WIP Status Report and Browse).

You cannot report hours, and no backflushing takes place with this transaction.

### WIP Adjust Transaction

You can reconcile actual WIP quantities with those recorded in your database by using the WIP Status Inquiry (18.22.12) or WIP Status Report (18.22.4.11). Labor hours cannot be entered, and no backflushing takes place. When quantities do not match, use WIP Adjust Transaction (18.22.21) to adjust quantities at an operation's input, output, or reject queues. The current queue balances display when you run the program.

- When you adjust the output or reject queues, you change their balances at the current operation.
- When you adjust the input queue, the net change is made to the prior operation's output queue as well as to the current operation's input queue.

Each adjustment creates operation history records and generates GL transactions. A queue increase debits WIP and credits the Inventory Discrepancy account. Negative adjustments credit WIP and debit the Inventory Discrepancy account. You can designate a GL account, sub-account, and cost center for the transaction. The default is the Inventory Discrepancy account from Product Line Maintenance (1.2.1) or Inventory Account Maintenance (1.2.13).

Open schedule quantities are also updated by this transaction. Increases in the balances of the final operation's output queue increase scheduled completions and vice versa.

### Move Transaction

Move Transaction (18.22.19) transfers quantities from an operation's output queue to the following operation's input queue. For the final operation, items are moved to finished material inventory. In this case, the Modify Receipt field lets you modify the default list of sites, locations, lot and serial numbers, and quantities.

You cannot report labor hours. This transaction normally has limited use, since an operation can be set to have the backflush transaction and rework transaction perform this task automatically.

### Reporting Downtime and Non-productive Labor

Use Down Time Transaction (18.22.20) and Non-productive Labor Feedback (18.22.22) for reporting. These transactions do not charge costs against WIP. Both debit Cost of Production and credit Labor.

Down Time Transaction references the cumulative order, operation, item, production line, and site. Non-productive Labor Feedback lets you enter a GL project code and record comments.

You can enter reason codes for both transactions, with type Downtime for Down Time Transaction and type Down for Non-productive Labor Feedback.

### Post Accumulated Usage Variances

Post Accumulated Usage Variances (18.22.9) calculates and posts accumulated usage variances in cumulative orders, according to the criteria entered. You can post usage variances on demand without having to close the cumulative order.

For each open cumulative order selected, usage variances are calculated by operation for component material, WIP material, labor, burden, and subcontract. The variances calculated are for the entire life of the cumulative order. The amounts to post are reduced by any amounts previously posted. Additionally, floor stock expense is posted.

See "Managing Cumulative Orders" on page 135.

### Component Material Usage Variances

Component material usage variance is calculated as the difference between the actual and expected quantities issued, extended by the cumulative order operation component cost. The expected issue quantity is the cumulative order operation standard quantity required per unit multiplied by the quantity processed at the operation. When you issue component materials that are not in the cumulative order BOM for that operation, they are considered nonstandard and treated entirely as usage variance.

### WIP Material Scrap Usage Variances

WIP material scrap usage variance is calculated as the difference between the actual and expected scrap quantities, extended by the cumulative order operation cost. The expected scrap quantity is the quantity processed less the cumulative order expected yield for that operation. For example, if the yield factor at an operation is 75%, and 100 units were processed at the operation, the expected scrap quantity would be 100 less 75%, or 25. The variance amount is posted to the Scrap account from the end-item product line.

You can scrap a quantity without producing a scrap posting. Consider the above example where yield is 75% and the expected scrap quantity is 25. If the actual quantity scrapped is 25, then no variance results. If there is no labor or component usage variance elsewhere, WIP is charged with exactly the amount of resources expected to produce 75. This is reflected in the fact that the operation cost includes an expected scrap amount.

If scrap is always posted regardless of yield, then Include Yield in Repetitive Control should be No. This sets the cumulative order yields to 100%.

See “Include Yield” on page 118.

Usage variances are posted only if GL standard costing is in effect for the finished item. Usage variances are not posted if GL average costing is in effect.

### Labor and Burden Usage Variances

Labor and burden usage variances are calculated as the difference between actual and expected labor hours, extended by the cumulative order operation labor or burden rate. The expected labor hours equal the cumulative order operation standard labor hours per unit multiplied by the quantity processed at the operation.

### Usage Variance Transaction Records

The system records each usage variance posting by creating an operation history record with one of the following types:

- MUV-CMP (material usage variance—component)
- MUV-WIP (material usage variance—work in process)
- FLOORSTK (floor stock expense)
- RLUV (run labor usage variance)
- RBUV (run labor burden usage variance)
- SLUV (setup labor usage variance)
- SBUV (setup labor burden usage variance)

SUV (subcontract usage variance)

You can run this program in a non-update mode. In this case, the report is generated, but no database updates occur.

## Generating Repetitive Reports

Table 8.3 lists reports on the Reports Menu, with a brief description of their purpose.

**Table 8.3**  
Repetitive Reports

Report	Description
WIP Status Inquiry (18.22.12)	Displays quantities in the input, output, and reject queues for an operation.
WIP Status Report (18.22.4.11)	Generates a report of WIP queue quantities for all operations in selected cumulative orders. The report also shows the cumulative activities affecting each of the queue quantities, such as cumulative completed, scrapped, adjusted, rejected, reworked and moved to next operation.
Operation Transaction Inquiry (18.22.4.1)	Displays repetitive operation history records.
Scrap Analysis Report (18.22.4.3)	Displays percentages scrapped by reason code over an interval of time compared to the quantity completed in that interval.
Reject Analysis Report (18.22.4.4)	Displays percentages rejected by reason code over an interval of time compared to the quantity completed in that interval.
Rework Analysis Report (18.22.4.5)	Displays percentages reworked by reason code over an interval of time compared to the quantity completed in that interval.
WIP Adjustments Analysis Reports (18.22.4.6)	Displays WIP adjustments over an interval of time.
Cumulative Order Cost Report (18.22.4.10)	Displays all data related to costing captured in the cumulative order when it is created. It reports by operation the product structure and component costs, labor hours per operation, labor cost per hour, burden factors, yield factor, subcontract cost, and the group of costs.
Operations Numbering Report (18.22.4.12)	Displays operation transaction history by number or date range. Transaction sequence numbers apply to the database as a whole; as a result, transactions within a domain may appear to have gaps. This report lets you see transactions created in all domains and verify that numbering is sequential.

Report	Description
WIP Valuation Report (18.22.4.13)	Reports the value of the WIP queues at the operation costs contained in the selected cumulative orders. Either the cumulative order operation standard costs, the cumulative order average costs, or the current GL standard operation costs can be used for valuation. You have the option to display cost elements.
Scrap and WIP Adjustments Valuation Reports (18.22.4.14 and 18.22.4.15)	Reports the value of material scrapped/adjusted within an interval of time. The data can be sorted by either site and item or by descending value. Either the cumulative order operation standard costs, the cumulative order average costs, or the current GL standard operation costs can be used for valuation. You have the option to display cost elements.

## Managing Subcontracting

Use Advanced Repetitive with other programs to manage subcontract operations. You can:

- Track item quantities sent to and received from subcontractors by updating subcontract shippers with receipt, return, and scrapped quantities.
- Save processing steps by combining receipt and inventory placement of the finished item from the subcontractor.
- Define multiple subcontractors for a single routing and operation.
- Optionally, use subcontractors other than those defined for the subcontract operation.
- Scrap subcontract materials during receipt or using a separate program also using the receipt function.
- View subcontractor activity and history through inquiries and status reports.
- Receive lot/serial-controlled items into inventory.

### Subcontracting Overview

Subcontract operations vary, depending on whether your company subcontracts WIP lot- or serial-controlled items, how many subcontractors you use to perform the same operation on the same item-site-routing combination, and where in the routing you use subcontract services.

If your company uses WIP Lot Trace (WLT) to control items, setup and transactions for subcontract operations may involve additional WLT-related steps.

See Chapter 10, “WIP Lot Trace,” on page 189.

If you typically use more than one subcontractor in your WIP operations, you can optionally activate features that improve visibility and efficiency in managing multiple subcontract operations.

If your subcontract services are the last operation in a WIP item’s routing, you can save processing steps by combining receipt and inventory placement of the finished item from the subcontractor.

**Note** If WIP item components are lot/serial controlled, you must use the Advanced Repetitive Move Transaction (18.22.19) to record the WIP item placement into inventory. If only the WIP item is lot/serial controlled, then the placement of inventory occurs during receipt.

Subcontract processing requires the use of several modules. Although most of the processing occurs in the Advanced Repetitive module, you must complete setup steps in other modules as well as Advanced Repetitive. All setup tasks are described here.

## Setting Up Preliminary Subcontract Data

This section describes tasks you complete before you can begin shipping items to and receiving items from subcontractors. Setting up this data saves you time and extra steps once you begin Advanced Repetitive operations.

**Fig. 8.16**  
Preliminary Subcontract Setup

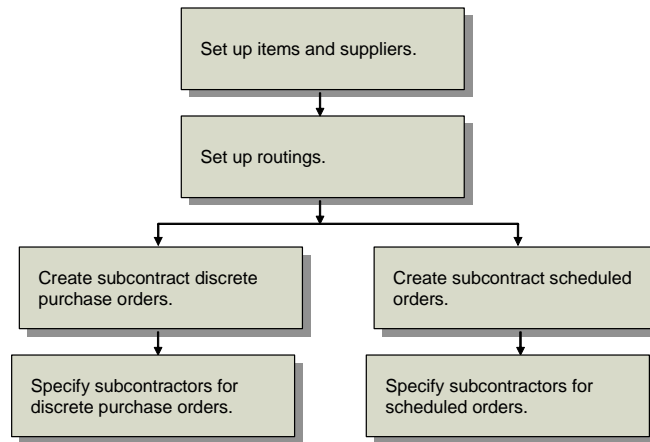

Data setup varies depending on whether you are using discrete purchase orders or scheduled orders.

## Setting Up Subcontract Items and Suppliers

Using WIP items helps ensure consistent pricing for subcontract services. Use WIP items to represent services being purchased from subcontractors. For example, you can use HEAT-TREAT-SERVICE as a WIP item for a subcontractor.

Set up WIP items in Item Master Maintenance (1.4.1) before entering them on supplier schedules. Enter the routing code in the Routing Code field in the Item Planning Data frame. The routing code you enter here defaults to Advanced Repetitive operations.

Use Standard Operation Maintenance (14.9) to set up subcontractors as suppliers in your standard operations. Enter a code for the subcontractor in the Supplier field.

See *User Guide: QAD Master Data*.

## Setting Up Subcontract Routings

There are a few subcontract-related fields that you can set when defining the routing for an item in Routing Maintenance (14.13.1).

**Fig. 8.17**  
Routing Maintenance (14.13.1)

Set these fields for subcontract operations.

**Work Center.** Set up subcontractors as work centers. You can use codes such as PAINT, HEAT, or STAMP for subcontractor work. You can also enter a supplier code, if you set up your subcontractor as a supplier in your standard operations.

**Subcontract LT.** Enter the average number of calendar days it normally takes a subcontractor to perform the operation. You should enter either subcontract cost and lead time or setup, run, and move time. Specifying both can overstate lead time and result in incorrect schedules.

**Subcontract Cost.** Enter the average cost per unit normally charged by the subcontractor to perform the operation. Cost calculation functions determine item costs based on subcontract cost. Enter either subcontract cost and lead time or setup, run, and move time. Specifying both can overstate cost and lead time and result in incorrect schedules.

**WIP Item.** Enter the item that represents WIP material for the subcontractor. Sub Shipper Print (18.22.5.9) uses this field to provide the description and unit weight on the subcontractor shipper.

**Move Next Operation.** This field sets the default for the same named field in Repetitive Backflush (18.22.13). Move Next Op at the milestone operation before the subcontracting operation must be No. Sub Shipper Issue (18.22.5.11) transfers items from the output queue of the previous milestone (reported) operation into the input queue of the subcontract operation.

## Creating Subcontract Orders

You can use either supplier scheduled orders or purchase orders to handle the purchasing side of a subcontract operation.

You create supplier scheduled orders using Supplier Scheduled Order Maintenance (5.5.1.13). You create discrete subcontract purchase orders using Purchase Order Maintenance (5.7).

Fields in Supplier Scheduled Order Maintenance or Purchase Order Maintenance play an important role in subcontract operations.

See *User Guide: QAD Scheduled Order Management*.

In the line-item frame, specify the item being sent to the subcontractor and the site that receives the item when the subcontractor finishes the service.

**Fig. 8.18**  
Supplier Scheduled Order Maintenance (5.5.1.13)

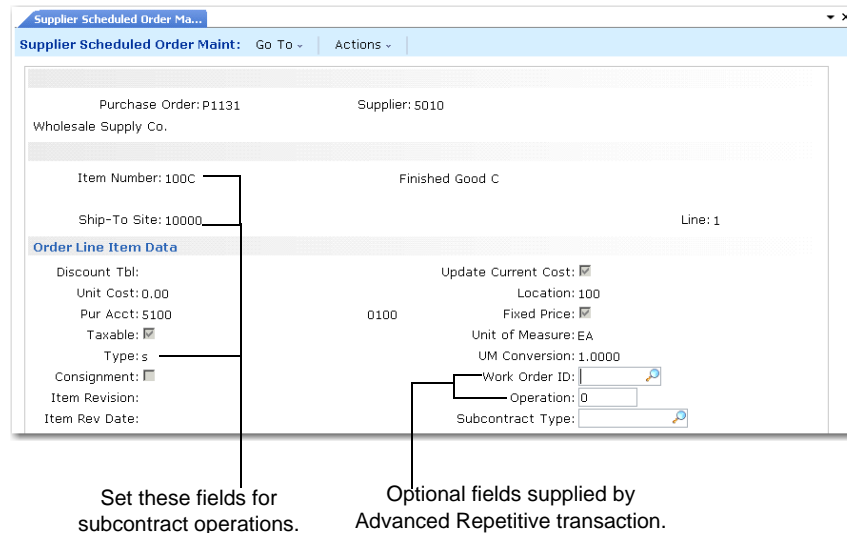

In the Order Line Item Data frame, set the following:

**Type.** Enter S to specify that the line item is for a subcontract operation. The Type field defaults from the Memo Order Type in Item Master Maintenance (1.4.1) and determines the effect of inventory, planning, and cost accounting when the item is received. When you set the field to S, a work order number, lot ID, and operation are specified on the order and on the receipt. When the receipt is processed, work order operation status is updated and a GL transaction debits the WIP account from the work order.

**Work Order ID.** Enter the work order ID or cumulative order ID associated with the subcontract item. When you use Advanced Repetitive features, you can leave this field blank. The system validates this field when the order type is S and automatically updates the ID when it creates a cumulative ID in Advanced Repetitive transactions.

**Operation.** Specify the operation code for the operation that the subcontractor performs. When you use Advanced Repetitive features, you can leave this field blank. The system validates this field when the order type is S and automatically updates the operation field when it creates a cumulative ID in Advanced Repetitive transactions.

When you execute Schedule Update from MRP (5.5.3.1), the system creates the subcontract lines on the scheduled purchase order to produce schedules for subcontracted services.

## Specifying Subcontractors for a Routing Operation

If your company contracts various subcontractors for one routing operation, you can associate each subcontract with a single routing operation.

If you use scheduled orders for subcontracts, use Subcontract Order MRP % Maint (5.5.1.21) to associate subcontractors with a single routing operation. If you use discrete purchase orders, use Subcontract Routing Op/PO Maint (5.11).

When you specify subcontract orders for a specific routing operation, the system uses the information to:

- Create schedules for subcontractors, if using scheduled orders.
- Set defaults in Advanced Repetitive subcontract shipper programs.
- Find subcontract purchase orders and automatically update the cumulative ID and Operation fields when an Advanced Repetitive transaction creates a cumulative ID.
- Populate subcontract-related browses and reports.

### Specifying Subcontractors for Scheduled Orders

In Subcontract Order MRP % Maint, you allocate a percentage of the total subcontract services required for the routing operation to each subcontractor. Enter the site, item, effective date, routing, and subcontract operation in the header.

Then enter the percentage for each subcontract order in the Purchase Order Percents frame. Percentages must equal either 100% for each item or be 0%. If 0%, the system does not allocate planned orders for the scheduled order. To phase in new percentages, enter the same ship-to site, item number, routing, and operation with different effective dates.

You must set the subcontract order MRP % allocation record effective date within the scheduled order effective date range. Enter the MRP % effective date in the Effective field in the header, then select orders with:

- Start effective dates that are after the MRP % effective date.
- End effective dates that are before the MRP % effective date.

**Note** Orders with a 0% allocation do not have to fall within this date range.

The system displays the line end effective date in the End Effective field in the Purchase Order Percents frame. This date indicates when the scheduled order line is no longer active.

You can modify the percentage or remove a record if the end effective date is earlier than the system date and the order is closed as long as remaining records equal 100% for each item or are 0%.

**Fig. 8.19**  
Subcontract Order MRP % Maint (5.5.1.21)

Order	Percent	Line	End Effective
P1131			

### Specifying Subcontractors for Discrete Purchase Orders

In Subcontract Routing/Op PO Maint, enter the site, item, effective date, routing, and subcontract operation in the header, then enter either the supplier or the PO number and line number. You cannot enter the line number without entering the PO number. The system then connects subcontract purchase orders to a routing and operation based on the supplier. You cannot allocate percentages for orders with this program.

**Fig. 8.20**  
Subcontract Routing/Op PO Maint (5.11)

Supplier	Order	Line
EDSsup01	P1126	1

## Setting Up Advanced Repetitive for Subcontract Operations

For subcontract operations in Advanced Repetitive, set up schedules and subcontract shipping control options.

### Setting Up Schedules

Use Schedule Maintenance (18.22.2.1) to set up repetitive schedule requirements for a subcontracted item. The repetitive schedule defines how much of an item can be manufactured per day and provides visibility to the quantity per day that requires subcontracted services.

See “Schedule Maintenance” on page 130.

### Defining Subcontract Shipping Control Options

You set subcontract shipping options in Subcontract Shipping Control (18.22.5.24). The options let you ship items to alternate subcontractors, manually track subcontract shipper numbers sent to and received back from a subcontractor, and scrap items that the subcontractor does not return.

**Fig. 8.21**  
Subcontract Shipping Control (18.22.5.24)

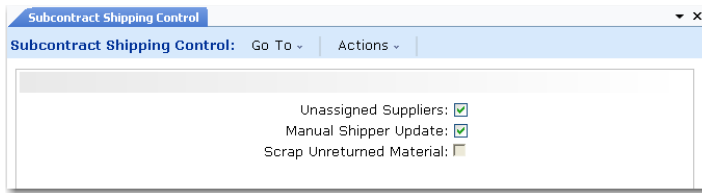

*Unassigned Suppliers.* Indicate if you want to restrict subcontractors to those specifically assigned to a routing operation when you create the subcontract shipper.

No (the default): You can specify only subcontractors associated with the routing and operation when creating the subcontract shipper.

Yes: You can specify subcontractors not associated with the routing and operation when creating the subcontract shipper.

**Note** You specify scheduled orders for a specific routing and operation in Subcontract MRP % Maint (5.5.1.21). You specify discrete purchase orders for a specific routing and operation through Subcontract Routing/Op PO Maint (5.11).

When you create a subcontract shipper, you can specify a cumulative ID. The system populates subcontract shipper fields with the subcontractor data associated with the ID. To be able to associate a subcontract shipper with a different subcontractor, set this field to Yes.

See “Specifying Subcontractors for a Routing Operation” on page 152.

**Example** Your company uses three different subcontractors to paint item A, bicycle frames: subcontract suppliers A, B, and C. Work order 20 specifies that item A is painted red. In Subcontract Routing/Op PO Maint, you specify the subcontract PAINT operation and routing for subcontract supplier A and B only. If you set this field to Yes, you can specify subcontractor supplier C on the subcontract shipper with item A, work order 20, the subcontract PAINT operation, and other data associated with the order. If you set this field to No, you can only specify subcontract supplier A or B on the subcontract shipper.

*Manual Shipper Update.* Indicate if you want to manually track subcontract activity by connecting subcontract shipper numbers to subcontract purchase order lines when you receive or return items.

No (the default): The system automatically updates subcontract shipper records with receipt or return quantities.

The system updates the open subcontract shipper with the oldest ship date. As open subcontract shippers are consumed (closed), the system updates the next open subcontract shipper with the oldest ship date and so on.

Yes: The system lets you specify the subcontract shipper and updates the subcontract shippers with the quantities received or returned, beginning with the shippers you selected.

When Yes, the system displays the Subcontract Shippers frame in Purchase Order Receipts (5.13.1), Purchase Order Returns (5.13.7), and PO Shipper Maintenance (5.5.5.5 and 5.13.14). Use the frame to:

- View and associate multiple subcontract shippers with the receipt or return.
- View WIP lot/serial numbers of items being received or returned.
  - Indicate whether the subcontract shipper is fully received even when the quantity received does not match the original quantity shipped.

- Scrap unreturned material.
- Enter comments about the receipt.

*Scrap Unreturned Material.* Indicate if you want to be able to scrap the quantity short from the subcontractor when you receive or return subcontract items. You cannot set this field to Yes unless Manual Shipper Update is Yes.

No (the default): You cannot specify a scrap quantity when you receive or return items. The system does not register a scrap transaction for the quantity short. If No and you have subcontract items to scrap, you should manually enter the scrap quantity through Advanced Repetitive Scrap Transaction (18.22.18) or Subcontract Scrap Transaction (18.22.5.13).

Yes: You can enter the quantity scrapped when you receive or return items using Purchase Order Receipts (5.13.1) and Purchase Order Returns (5.13.7).

The system updates the subcontract shipper you select and registers a scrap transaction for the quantity you specify in the Subcontract Shippers frame.

To scrap unreturned subcontracted items, the quantity received must be less than the quantity indicated on the subcontract shipper, minus the quantity already received.

See “Viewing Subcontracted WIP Materials” on page 165.

## Processing Subcontract Shipments

If you are processing WLT-controlled items for subcontract shipping, additional processing occurs. This includes additional WLT frames that display when you process a subcontract order.

See Chapter 10, “WIP Lot Trace,” on page 189.

Figure 8.22 depicts the tasks involved when processing a subcontract shipment that is not WLT-controlled.

**Fig. 8.22**  
Subcontract Shipping Process

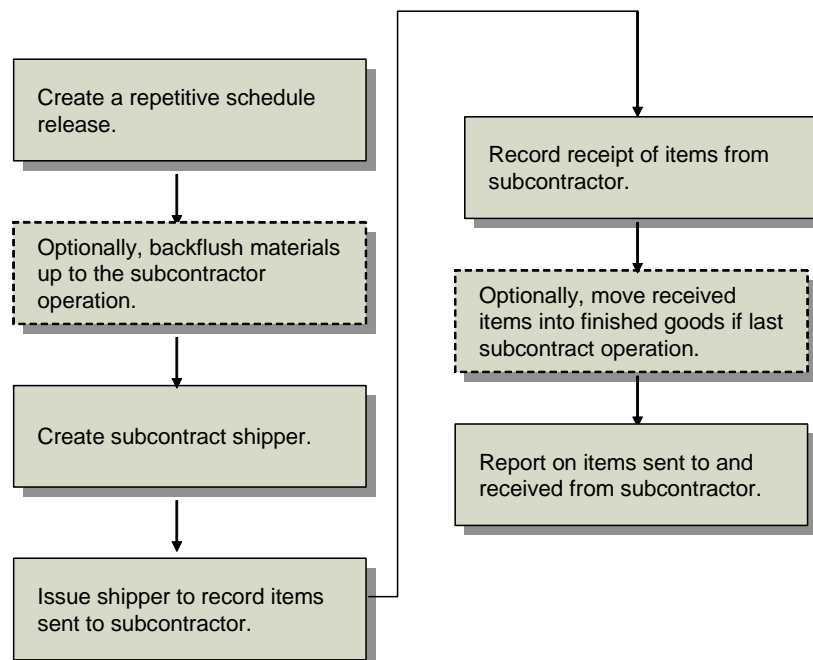

## Creating Repetitive Schedule Releases

Use Schedule Explosion (18.22.2.4) to explode the subcontract schedule. When you explode a repetitive schedule, the system creates the scheduled work orders, generating component demands for each item and day.

**Note** The generated work orders are identified as a type S. The S indicates a scheduled work order, not a subcontract work order.

Next, create the subcontract schedule release by running Schedule Update from MRP (5.5.3.1). Schedule Update from MRP uses the percentages you defined to allocate MRP planned orders for the item among subcontractors.

See “Specifying Subcontractors for a Routing Operation” on page 152.

Transmit the schedules to subcontractors using Schedule Print (5.5.3.8), Schedule Print in Fax Format (5.5.3.9), or Supplier Shipping Schedule (35.4.8) if you are using EDI eCommerce to export schedules in electronic data interchange (EDI) format.

See *User Guide: QAD EDI eCommerce*.

## Backflushing Subcontract Materials

You can use Backflush Transaction (18.22.13) to optionally backflush components up to the subcontractor operation and create a cumulative work order and its ID to track subcontractor activity.

When the system creates the cumulative work order, it assigns a work order ID. The system automatically updates blank work order ID fields on subcontract order lines with the new ID if you connected a subcontract:

- Discrete purchase order to the subcontract routing and operation through Subcontract Routing/Op PO Maint (5.11).
- Scheduled order to the subcontract routing and operation in Subcontract Order MRP % Maint (5.5.1.21).

Also, the system automatically populates the subcontract operation on subcontract purchase order lines. Therefore, you do not have to return to purchase order maintenance programs to enter the work order ID and subcontract operation.

In Backflush Transaction, set Move Next Op to No for subcontractor operations. Since the backflush operation is prior to the subcontract operation, you set Move Next Op to No because subcontract shipping functionality moves WIP material from the prior operation to the subcontract operation.

**Fig. 8.23**  
Backflush Transaction (18.22.13)

The screenshot shows the 'Backflush Transaction' window with the following fields and annotations:

- Employee:** MFS01
- Effective:** 06/18/2007
- Shift:** (blank)
- Site:** 10000
- Item Number:** WLT18-P1
- WIP Lot Std Rep:** (blank)
- Operation:** 10
- Line:** 1000
- Repetitive Production Li:** (blank)
- Routing:** WLT18-P1
- BOM Code:** WLT18-P1
- ID:** 129
- Work Center:** 10000
- Department:** 10
- Qty Processed:** 0.0
- Qty Scrapped:** 0.0
- Qty Rejected:** 0.0
- Reject To Op:** 10
- Actual Run Time:** 0.0
- Earning Code:** (blank)
- Machine:** (blank)
- General #** 1
- UM:** EA
- Reason Code:** (blank)
- Reason Code:** (blank)
- Modify Backflush:**
- Conversion:** 1.0000
- Multi Entry:**
- Multi Entry:**
- Move Next Op:**
- Start Time:** (blank)
- Elapsed or Stop Time:** (blank)

Annotations below the window:

- Line pointing to 'Modify Backflush': Set to No for subcontract operations.
- Line pointing to 'ID: 129': Updates subcontract purchase orders with this ID.

### Creating Subcontract Shippers

Use Sub Shipper Maintenance (18.22.5.5) to create shippers for shipment of items to subcontractors. The subcontract shipper can consist of container items, WIP items, and the components used at this operation that are also being shipped to the subcontractor.

You specify only one subcontractor per subcontract shipper. Identify the subcontractor in the Ship-To/Dock field in the header frame. You indicate the correct work order or cumulative ID, routing, operation, item, production line, and other data pertinent to this subcontractor shipment in the Contents (Items) frame.

You can use the subcontractor data in the Contents (Items) frame for a subcontractor other than the subcontractor defined for the item's routing and operation by setting Unassigned Suppliers to Yes in Subcontract Shipping Control (18.22.5.24).

See "Defining Subcontract Shipping Control Options" on page 153.

**Note** Use Subcontract Routing/Op PO Maint (5.11) to specify subcontract suppliers for a specific routing operation or use Subcontract MRP % Maint (5.5.1.21) to specify scheduled orders for a specific routing operation.

When you enter an open cumulative work order ID in the Contents (Items) frame, the system automatically updates the following fields in the Contents (Items) frame with data from the cumulative work order:

- Effective Date
- Site
- Item Number
- Production Line
- Routing
- BOM Code

Conversely, when you enter data in the fields listed above, the system automatically updates the ID field with the correct cumulative work order ID.

Figure 8.24 shows the Sub Shipper Maintenance Contents (Items) frame.

**Fig. 8.24**  
Sub Shipper Maintenance, Contents (Items) Frame (18.22.5.5)

The screenshot shows a software window titled "Sub Shipper Maintenance" with a "Contents (Items)" section. The fields are arranged as follows:

- Effective Date: 06/18/2007
- Site: 10000
- Item Number: [ ]
- Operation: [ ]
- Production Line: [ ]
- Routing: [ ]
- BOM Code: [ ]
- ID: [ ]
- Quantity: [ ]
- UM: [ ]
- UM Conv: [ ]
- Location: [ ]
- Lot/Serial: [ ]
- Reference: [ ]
- WIP Item: [ ]
- Multi Entry:
- Comments:

**Effective Date.** Enter the effective date of the transaction. The system searches open cumulative orders that pertain to the effective date.

**Site.** Enter the site from which the subcontract material will be shipped.

**Item Number.** Enter the item to be shipped to the subcontractor.

**Operation.** Enter the number of the subcontract operation on the routing for this item.

**Production Line.** Enter the production line on which the item is manufactured.

**Routing.** Enter the routing code for the items being shipped.

**BOM Code.** Enter the BOM code for the items being shipped.

**ID.** Enter the ID of the work order associated with the items being shipped.

**Quantity.** Enter the quantity of the items being shipped to the subcontractor.

**UM Conv.** Enter the unit of measure conversion for the item.

**Location.** Enter the location of the items to be shipped.

**Lot/Serial.** Optional. Enter the lot/serial number for the items shipped on this subcontract shipper if items are tracked by lot or serial number.

**Reference.** Enter the optional lot reference number for the items shipped on this subcontract shipper.

**WIP Item.** The system displays the WIP item number indicated in the routing operation.

**Multi Entry.** Indicate whether this transaction references multiple sites, locations, lot number, serial numbers, or lot reference numbers.

**No:** This transaction is processed using values you enter on this screen.

**Yes:** Another entry screen displays letting you enter multiple lines for this transaction. The system creates an individual transaction history record for each transaction line. The total of all lines is used to update the inventory balance.

**Comments.** Enter comments about the shipment.

## Issuing Subcontract Shippers

Confirm the subcontract shipper using Sub Shipper Issue (18.22.5.11). For the quantities identified on the subcontract shipper, the equivalent of a move transaction is performed from the output queue of the operation preceding the subcontract operation. If the preceding operation is a non-milestone, then non-milestone backflushing takes place for that operation and any other preceding non-milestone until the quantity requirement is either satisfied or another milestone operation is encountered.

For component material requirements of the subcontract operation, the system performs the equivalent of an inventory location transfer. Inventory is transferred from the site and location entered on the subcontract shipper to the cumulative order site and operation work center location, if there is a corresponding record in the location master. Otherwise, the inventory is transferred to the item default location.

## Receiving Completed Subcontract Items

You receive shipments from the subcontractor using Purchase Order Receipts (5.13.1) or PO Shipper Maintenance (5.5.5.5 and 5.13.14).

If you use Purchase Order Receipts, the receipt of subcontract items:

- Moves goods out of subcontract operations
- Creates GL transactions
- Backflushes components used in the subcontract items

If you use PO Shipper Maintenance, you can record the subcontract receipt and take time to compare the actual received items against the receipt quantity.

Use PO Shipper Receipt (5.5.5.11 and 5.13.20) to update inventory and the GL after you manually verify received subcontract items and quantities with PO Shipper Maintenance.

**Note** PO Fiscal Receiving (5.13.16) functions similarly to PO Shipper Maintenance; however, fiscal receipts are typically for inventory as opposed to receipts for subcontracted services. Therefore, subcontract shipping receipt functionality as described in this section does not apply to PO Fiscal Receiving.

## Connecting Shippers to Received Items

When receiving subcontracted items, you can connect subcontract shippers to the receipt for more subcontract visibility.

For more information on connecting shippers, see page 154.

When you connect a subcontract shipper ID to purchase order lines you are receiving against, you can also:

- Place the items into finished goods automatically if the subcontract operation is the last operation and the items are lot- or serial- controlled. See “Moving Finished Subcontract Items to Inventory” on page 165.

**Note** If WIP item components are lot/serial controlled, you must use the Advanced Repetitive Move Transaction (18.22.19) to record the WIP item placement into inventory. If only the WIP item is lot/serial controlled, then the placement into inventory occurs during receipt.

- Optionally scrap unreturned subcontracted items.
- Optionally close the subcontract shipper.

To receive against a subcontract shipper, set Manual Shipper Update to Yes in Subcontract Shipping Control (18.22.5.24). When you set this field to Yes, the Subcontract Shippers frame displays in Purchase Order Receipts (5.13.1), PO Shipper Maintenance (5.5.5.5 or 5.13.14), and Purchase Order Returns (5.13.7). After you select a shipper, the system displays shipper data in the lower portion of the screen.

See “Defining Subcontract Shipping Control Options” on page 153.

**Fig. 8.25**  
Subcontract Shippers Frame (5.13.1)

Shipper Number	Lot/Serial	Reference	Open Qty	Receipt Qty
SH01			n.nn	n.nn

Shipper Number: SH01  
 Lot/Serial:  
 Reference:  
 Receipt Quantity: 0.0  
 Scrap Quantity: 1.0  
 Comments:

**Shipper Number.** Accept the ID that displays or enter another ID of the subcontract shipper you want to track. Entering the number here lets you track subcontract shippers sent to and received from subcontractors. Use Subcontract Item Status Report (18.22.5.16) to display the status and history of items sent to and received from subcontractors.

**Lot/Serial.** If the item is lot- or serial-controlled, enter the lot/serial number for the items received on this purchase order line if items are tracked by lot or serial number.

**Reference.** Enter the optional lot reference number for the items received on this purchase order line.

**Receipt Quantity.** Enter the quantity of items you received from the subcontractor. The system tracks the receipt quantity for the subcontract shipper you specified. This information displays as received quantities in the subcontract shipping programs.

If you enter a positive quantity, the system considers this a received quantity if you are in a receipt program or a returned quantity if you are in a return program. The system updates the shipper you selected with the quantity. If you select a subcontract shipper that has an expired cumulative order associated with it, the system uses the current cumulative ID on the scheduled order.

See “Returning Items to Subcontractors” on page 161.

If you enter a negative quantity, the system considers this as a return quantity if you are in a receipt program. The system updates the shipper you selected with the quantity.

When entering a quantity, note the following:

- The quantity you receive cannot exceed the quantity on the subcontract shipper.

- The total quantity for all specified subcontract shippers cannot exceed the total purchase order receipt quantity

**Scrap Qty.** Enter the quantity you want to scrap. To enter a quantity, you must set Scrap Unreturned Material to Yes in Subcontract Shipping Control (18.22.5.24). If you enter a scrap quantity that equals the open quantity, the system closes the subcontract shipper. See “Scrapping Subcontract Items” on page 162.

**Note** You cannot enter a scrap quantity in PO Shipper Maintenance (5.5.5.5 and 5.13.14).

**Close Sub Shipper.** This field lets you indicate whether the entire subcontract shipper is complete or not. You can specify the subcontract shipper as fully received even when the quantity received does not match the original quantity shipped.

If you reopen a previously closed subcontract shipper and the cumulative ID has expired, the system uses the ID from the scheduled order.

No: The subcontract shipper is not complete and remains open.

Yes: The entire subcontract shipper is complete. If there are several lines for the same subcontract shipper, setting this field to Yes on just one line updates all lines for that subcontract shipper as closed.

For example, for a subcontract shipper that includes four lines, if you set this field to Yes because you received the entire shipment of line 1, then the system sets the Close Sub Shipper field to Yes for the remaining three lines, too.

**Comments.** Enter comments about the receipt.

Use Subcontract Item Status Inquiry (18.22.5.17) to view the shipment status of subcontract items. Set Show Shipped Complete to Yes to display the complete status. If Show Shipped Complete is No, the system displays open subcontract shippers only. If Yes, the system displays both open and closed subcontract shippers.

When you receive subcontracted items, you can return items to the subcontractor, scrap items, or move finished items into inventory. The following sections cover these optional receipt-related tasks.

### Returning Items to Subcontractors

In some instances, you may have to return items to the subcontractor that you received. You can control whether subcontract shippers are manually updated with return quantities and return items against the same cumulative ID.

To return against a subcontract shipper, set Manual Shipper Update to Yes in Subcontract Shipping Control (18.22.5.24).

When you set this field to Yes, the Subcontract Shippers frame displays in the following programs for each different purchase order line against which you are returning items.

- PO Shipper Maintenance (5.5.5.5 and 5.13.14)
- Purchase Order Receipts (5.13.1)
- Purchase Order Returns (5.13.7)

See “Defining Subcontract Shipping Control Options” on page 153.

Use the following procedure to return items against a subcontract shipper:

- 1 Select a subcontract shipper from a list of all open and closed subcontract shippers in the Subcontract Shippers frame.
- 2 Choose one of the following:
  - a Enter a negative number in the Receipt Quantity field to indicate returned quantities if the Subcontract Shippers frame displays in PO Shipper Maintenance or Purchase Order Receipts. The quantity you enter cannot exceed the subcontract shipper quantity.
  - b Enter a positive number in the Receipt Quantity field to indicate returned quantities if the Subcontract Shippers frame displays in Purchase Order Returns. The quantity you enter cannot exceed the subcontract shipper quantity.
- 3 To return an item on a purchase order that is linked to a previously closed subcontract shipper, set Close Sub Shipper to No.

The system reopens the subcontract shipper and updates the received quantities to reflect the portion of the item quantity that you return. Once you update the quantity, the system opens the subcontract shipper for that quantity.

- 4 Add comments about why you are returning items or reopening the subcontract shipper in the Comments field.

**Fig. 8.26**  
Subcontract Shippers Frame

Purchase Order: BCP0A      Supplier: SUP01      Status:      RTV No:

**Subcontract Shippers**

Shipper Number	Lot/Serial	Reference	Open Qty	Receipt Qty
SH01			00.00	0.00

Shipper Number: SH01      Lot/Serial:

Receipt Quantity: 0.0      Reference:

Close Sub Shipper: [ ]      Scrap Quantity: 1.3

Comments: [ ]

Enter a positive quantity in a return program or a negative quantity in a receipt program.

Use Subcontract Item Status Report (18.22.5.16) to display total quantities returned to the subcontractor.

### Scraping Subcontract Items

If the quantity you receive from the subcontractor is less than the quantity indicated on the subcontract shipper, you can optionally scrap the items that you did not receive from the subcontractor.

There are two ways to register scrap items from subcontractors and update the subcontract shipper associated with the order:

- Scrap when receiving or returning items against a purchase order, using the Subcontract Shippers frame.
- Scrap through Subcontract Scrap Maintenance (18.22.5.13).

Both methods let you adjust the scrap quantity on subcontract shippers and register a scrap transaction with Advanced Repetitive.

**Note** You can also scrap items not returned from the subcontractor through Scrap Transaction (18.22.18); however, this method does not update subcontract shippers.

### Scraping Items Using the Subcontract Shippers Frame

When you scrap items using purchase order receipts or returns, you can:

- Complete the receipt as short and scrap the short.
- Do not complete the receipt as short and manually adjust WIP quantities using the scrap transaction of your choice.

Follow these steps to scrap the quantity at the subcontract shipper level:

- 1 In Subcontract Shipping Control (18.22.5.24), set Manual Shipper Update to Yes.  
This causes the Subcontract Shippers frame to display in Purchase Order Receipt (5.13.1) or Purchase Order Returns (5.13.7).

- 2 In Subcontract Shipping Control, set Scrap Unreturned Material to Yes.

This lets you enter a scrap quantity in the Subcontract Shippers frame when you receive or return items and update a subcontract shipper with the scrap quantity.

See “Defining Subcontract Shipping Control Options” on page 153.

**Note** The Subcontract Shippers frame also displays in PO Shipper Maintenance (5.5.5.5 or 5.13.14); however, you cannot enter scrap quantities in the frame and the Scrap Details frame does not display.

- 3 In the Subcontract Shippers frame, enter the quantity you are short in the Scrap Qty field.

**Fig. 8.27**  
Subcontract Shippers Frame, Scrap Quantity Field

Shipper Number	Lot/Serial	Reference	Open Qty	Receipt Qty
SH01			80.00	0.00

Shipper Number: SH01  
 Lot/Serial:  
 Reference:  
 Receipt Quantity: 3.0  
 Close Sub Shipper :   
 Scrap Quantity:   
 Comments:

**SCRAP DETAILS**  
 Employee:  Shift:  Queue:  Reason Code:

Set Subcontract Shipping Control option to edit this field, then enter the quantity to scrap.

The system informs you that unreceived quantities for subcontract shipper items will be scrapped and prompts you to continue.

**Note** If you enter a quantity that equals the open quantity, the system closes the subcontract shipper.

- 4 Specify Yes when prompted to continue.

Continue processing the receipt or return. When you are ready to complete the transaction, the Scrap Details frame displays.

**Note** The Scrap Details frame displays in Purchase Order Receipts (5.13.1) and Purchase Order Returns (5.13.7); see Figure 8.27.

- 5 Enter the employee code of the person reporting this labor in the Employee field.
- 6 Enter a code identifying the work shift associated with this operation in the Shift field.
- 7 Enter Input or Output in the Queue field to indicate the subcontract operation queue from which the items are scrapped.

**Note** If the subcontract operation is the first operation and WIP Lot Trace is enabled, you cannot update the queue and reason code.

**Input:** Enter Input if you want the system to adjust the scrapped material at the input queue of the subcontract operation. The system does not include subcontract labor and materials for the scrapped items when calculating the value of the scrapped material.

**Output:** Enter Output if you want the system to adjust scrapped material at the output queue of the subcontract operation. The system includes subcontract-consumed labor and materials for the scrapped items.

**Note** To scrap at the subcontract output queue, you must set Move Next Op to No in Purchase Order Receipts.

- 8 Enter a code for the reason items are scrapped.

**Note** You must create reason codes with a reason type of Scrap in Reason Codes Maintenance (36.2.17).

To scrap the quantity manually, set:

- Scrap Unreturned Material in Subcontract Shipping Control (18.22.5.24) to No.
- Close Sub Shipper in the Subcontract Shippers frame to Yes.
- Scrap the short amount using the scrap program of your choice.

#### Scrapping Items through Subcontract Scrap Maintenance

Use Subcontract Scrap Maintenance (18.22.5.13) to register a scrap transaction for subcontracted material against one or more subcontract shippers. This program:

- Registers a scrap transaction in Advanced Repetitive records
- Adjusts the scrap quantity on the subcontract shipper
- Removes quantities from the input and output queues of a subcontract operation

To register scrap through Subcontract Scrap Maintenance, use the following procedure:

- 1 Enter selection criteria in the header, including the item, supplier, site, ship date, subcontract shipper ID, and cumulative ID.

**Note** If the cumulative ID you entered expired but the subcontract shipper is not complete, the system may have replaced the cumulative ID on the purchase order. When this happens, the system finds the subcontract PO lines for the supplier you entered, then matches the item number on the new cumulative ID to the item number on the expired cumulative ID to determine which shipper to display.

- 2 Select a subcontract shipper from the display in the Subcontract Shippers frame.  
Information about the subcontract shipper displays in the Shipper Details frame. The fields are display only, except for Employee, Shift, and Scrap Qty.
- 3 Enter the scrap quantity.
- 4 When prompted, enter the employee and shift ID.  
**Note** The fields are identical to those that appear when scrapping in the Subcontract Shippers frame when receiving or returning subcontract items.

Use Subcontract Item Status Report (18.22.5.16) to view scrapped items.

See “Scrapping Subcontract Items” on page 162.

### Moving Finished Subcontract Items to Inventory

If the last operation is a subcontract operation and the items are lot or serial controlled, you can move items automatically into inventory during the receipt.

**Note** If WIP item components are lot/serial controlled, you must use the Advanced Repetitive Move Transaction (18.22.19) to record the WIP item placement into inventory.

Use Purchase Order Receipts (5.13.1) or PO Shipper Receipt (5.5.5.5 and 5.13.14) to place items received from subcontractors into finished goods automatically. You must Set Move to Next Operation to Yes in Purchase Order Receipts. The system displays the Receipt Data Input frame where you can edit received item information before an inventory record is created.

The system updates the quantity completed and reduces the quantity open on the repetitive schedule.

### Viewing Subcontracted WIP Materials

Table 8.4 lists reports and inquiries you can use to view or track subcontractor data.

**Table 8.4**  
Subcontract Reports/Inquiries

Report/Inquiry	Menu Number	Description
Subcontract Routing/Op PO Browse	5.12	Displays the supplier, PO number, and PO line for each discrete purchase order allocation detail record
WIP Status Inquiry	18.22.12	Displays where WIP material resides within the manufacturing process.
Sub Shipper/Container Inquiry	18.22.5.6	Displays subcontract shipper information. This program is the same as the subcontract shipper and container inquiries in Customer Schedules, except that Work Order ID and Operation replace PO, Order, and Line.

Report/Inquiry	Menu Number	Description
Subcontract Item Status Report	18.22.5.16	Displays status and history of items sent to and received from subcontractors. View either summary or detailed reports. Summary reports show a subset of data related to material in transit to and from a subcontractor. Detailed reports show subcontract shipper data for material in transit to and from a subcontractor. You can sort by: <ul style="list-style-type: none"> <li>• Work Center and Location: The work center represents the subcontractor.</li> <li>• Location and Work Center: The location is the location where subcontractors ship their completed subcontracted material</li> </ul>
Subcontract Item Status Inquiry	18.22.5.17	Displays a subset of data related to material in transit to and from a subcontractor.

## Deleting/Archiving Subcontract Purchase Orders

Before you can delete or archive a closed subcontract order, you must follow these steps to ensure that all records associated with the subcontract order are also deleted:

- 1 Delete all releases for the subcontract schedule in Schedule Maintenance (5.5.3.3).  
**Note** You can use Schedule Delete/Archive (5.5.3.23) to delete all releases when there are a large number of schedule releases.
- 2 Delete the MRP percentage in Subcontract Order MRP % Maint (5.5.1.21).
- 3 Delete records in Subcontract Routing/Op PO Maint (5.11).
- 4 Delete the subcontract scheduled order with Closed PO Delete/Archive.

You can use Closed PO Delete/Archive to delete and archive subcontractor purchase orders that do not have an associated active or inactive schedule.

## Subcontract Shipping Limitations in API Mode

When using programs in application programming interface (API) mode, the user interface is suppressed; therefore, the Subcontract Shippers frame and Receipt Data Input frame do not display when you receive subcontracted goods in:

- Purchase Order Receipts (5.13.1)
- PO Shipper Receipt (5.5.511)

Without the Subcontract Shippers frame displaying, you cannot:

- Scrap material
- Manually record a partial or full receipt against a subcontract shipper

See “Connecting Shippers to Received Items” on page 159.

**Note** You update a subcontract shipper during a receipt through Purchase Order Receipt, not PO Shipper Receipt.

You can manually process scrap by using Subcontract Scrap Maintenance (18.22.5.13).

Without the Receipt Data Input frame displaying, you cannot automatically move received material into finished goods. You must manually move the received material into finished goods. Use either of the following transactions to manually move received finished goods:

- Advanced Repetitive Move Transaction (18.22.19)
- Shop Floor Control Move Transaction (17.6)

See “Moving Finished Subcontract Items to Inventory” on page 165

Since you cannot update subcontract shippers during PO receipt while in API mode, the system automatically updates them for you. The system sorts shippers by effective date and cumulative ID and uses first-in-first-out (FIFO) and last-in-first-out (LIFO) logic to process them. The system updates shippers starting with the oldest shipper for the subcontractor being processed. This includes expired subshippers and closed cumulative orders that are not complete. If the system is processing a negative receipt, the system processes subshippers starting with the most recent subshipper.

## Working with Planning and Scheduling Workbenches

You can use the .NET UI-only Planning and Scheduling Workbenches to effectively view or manipulate schedule data in a single view. You can plan and schedule resources for a master schedule or a production schedule from a single workbench for each type of schedule.

You can select the Planning and Scheduling Workbenches from the .NET UI’s list of applications; you can select to run:

- Master Scheduling Workbench (MSW)
- Production Scheduling Workbench (PSW)
- Several QAD EE programs with supporting schedule data
- Component Availability Check (CAC)

You can concurrently plan and schedule production based on any or all aspects of production that are available because changes that you make to data in the MSW updates data in the PSW and vice versa.

For information on the Planning and Scheduling Workbenches, see *User Guide: Planning and Scheduling Workbenches*.

You must enable the workbenches by setting the Use Plan/Sched Workbenches field to Yes in Site Maintenance (1.1.13). Refer to *User Guide: Master Data* for more information.

You can also set up data and update the data in a mass method to use with the workbenches. You can set up items on production lines to be updated in a mass update method within QAD EE:

- Use Production Line Item Create (18.22.1.20) to set up items on production lines in a mass update method.
- Use Production Line Item Update (18.22.1.21) to update the production lines/item setup in a mass update method.

The following topics discuss the two programs.

## Production Line Item Create

Use Production Line Item Create (18.22.120) to set up items on production lines in a mass update method.

To use the .NET UI-only Planning and Scheduling Workbenches to work with either master or production schedules, you must have production lines and items set up. If you have existing records but want to avoid manual re-entry of setup data, you can use Production Line Item Create to:

- Mass set up items on primary production lines.
- Mass set up items on alternate production lines.

This ensures that the Planning and Scheduling Workbenches display data and alert the scheduler of all items requiring attention.

You can either process items for this work center machine or assign items to this site or production line. The program locates sites where the item routing contains a specified work center/machine, and for those items, associates—sets up—those items to a specified production line. The default item routing is the source for the work centers associated with an item.

The following figure depicts the relationship between production lines and work centers.

**Fig. 8.28**  
Work Center/Production Line Relationship

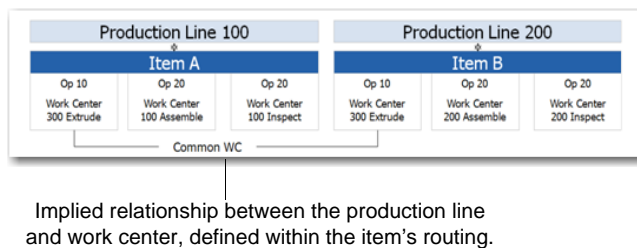

**Note** If the item has no routing (no item/resource record), the program does not find the item to associate with a production line.

You can run the program in batch mode to automate the process and eliminate the need to manually set up items on production lines.

The output report contains the following information:

- For each item, the current primary production and alternate production lines
- For each item, the new target production line

Once you associate items with the resource—that is, the work center, machine, or production line—you can update in mass using Production Line Item Update (18.22.121).

**Fig. 8.29**  
Production Line Item Create(18.22.1.20)

Process Items for this Work Center Machine:

*Work Center.* Specify the work center for which you want items set up for schedule processing using the .NET UI Planning and Scheduling Workbenches. Items and supporting data associated with this work center within the routing display in the workbenches.

*Machine.* Specify the machine for which you want items set up for schedule processing.

Assign Items to This Site/Production Line:

*Site.* Specify the site for the work center or machine.

*Production Line.* Specify the production line for which you want items set up for schedule processing.

*Update.* Specify Yes to update according to criteria you set here. Specify No to run a report of the mass update before you commit.

## Production Line Item Update

Use Production Line Item Update (18.22.1.21) to update the production lines/item setup in a mass update method. You mass set up production lines, machines, or work centers with items using Production Line Item Create.

Use Production Line Item Update to:

- Update/change the Pur/Mfg code for all items on a production line when you have not historically maintained the Pur/Mfg code.
- Apply the default production line run rate against all items on a production line.
- Apply run rates to production lines.
- Make a production line the primary line.
- Delete items from a production line.

The following table shows you the Pur/Mfg codes for production orders and order types.

**Table 8.5**  
Pur/Mfg Codes for Production Orders

Pur/Mfg Code	Production Order Status	Production Order Type
N/A	P	Generic
Blank	F	Discrete
M	F	Discrete
L	F	Repetitive
All others	F	Discrete

**Fig. 8.30**  
Production Line Item Update (18.22.1.21)

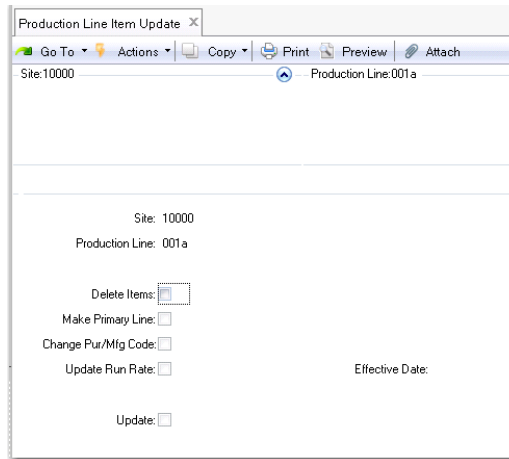

*Site.* Enter target site for the production line/items.

*Production Line.* Enter the target production line/items for applied actions.

*Delete Items.* Specify Yes to remove all items from production lines.

*Make Primary Line.* Specify Yes to change the primary line of the existing item/production line target relationship.

*Update Run Rate.* Specify Yes to apply the production line run rate against all items assigned to the target production line.

*Change Item Pur/Man Code.* Specify Yes to change the item master and site master (if it exists) Pur/Mfg code on all items associated to the production line.

# Repetitive

The Repetitive module supports high-volume manufacturing where lead times are one day or less, WIP is complete at the end of each day, WIP costs are tracked and batches do not overlap, or WIP costs are insignificant or fairly constant.

This chapter outlines the differences between Repetitive and Advanced Repetitive functions. Refer to Chapter 8, “Advanced Repetitive,” for a full discussion of repetitive functionality.

***Introduction*** 172

Outlines the differences between Repetitive and Advanced Repetitive.

***Setting Up Repetitive*** 172

Describes the settings in Repetitive Control.

***Simulating Schedules in the Workbench*** 174

Outlines when and how to set up simulated schedules using Line Schedule Workbench.

***Creating and Exploding Repetitive Schedules*** 174

Defines a repetitive schedule and describes how to update, maintain, and explode it.

***Using Repetitive Picklists*** 174

Outlines why repetitive picklists are used, how to calculate and print them, and how to transfer inventory if necessary.

***Managing Cumulative Orders*** 174

Describes how to create, close, and maintain cumulative orders and introduces Cumulative Order Maintenance.

***Executing Repetitive Transactions*** 174

Describes how repetitive transactions deal with operation reporting, completions, and scrap.

***Checking Component Availability*** 177

Illustrates how to use Component Check browse collections to check component availability, and calculate availability for work orders.

## Introduction

The Repetitive module provides many of the basic features of Advanced Repetitive, but differs in some significant respects:

- You can only post usage variances when you close a cumulative order.
- You do not have the same control over the assignment of start and end effective dates.
- You do not have as many options for reporting and tracking WIP throughout the life of the cumulative order. In addition, you cannot transfer WIP from an order that is being closed to a new order.
- You cannot report detailed information about scrap, reject, and rework quantities or enter multiple reason codes.
- Repetitive does not have the integrated support for managing subcontracting operations— from shipping to receiving.
- You can only report against milestone operations.
- Repetitive uses a consume forward or backward logic when completions exceed scheduled quantities. Advanced Repetitive always uses the earliest open schedule.
- Advanced Repetitive has additional utility programs that let you modify the quantity completed on a repetitive schedule and delete schedules as needed.

See “Distinctive Features of Advanced Repetitive” on page 114.

**Note** The WIP Lot Trace (WLT) module affects some features of the Advanced Repetitive and Repetitive modules. WIP Lot Trace is available as menu option 3.22.13. When activated, additional frames display in some programs. The discussion in this chapter assumes that WLT features are not active. For details, Chapter 10, “WIP Lot Trace,” on page 189.

## Setting Up Repetitive

Setup activities for Repetitive are almost exactly the same as for Advanced Repetitive. You need the same kind of base data such as items, sites, locations, employees, product structures, and routings.

The programs used to set up production lines, allocation percentages, shifts, and changeover times are identical in both modules.

See “Setting Up Production Lines” on page 119.

## Defining Control Program Settings

Settings in Repetitive Control (18.24) differ from those in Advanced Repetitive.

**Fig. 9.1**  
Repetitive Control (18.24)

*Next Picklist and P/L Prefix.* Same as Repetitive Control (18.22.24) in Advanced Repetitive.

*Consume Forward and Consume Back.* These fields, in coordination with Start of Week, determine how the system handles item completions that exceed the quantity scheduled for a given day.

When Consume Back or Consume Forward is nonzero and you record more completions than scheduled, the system consumes open quantities on past schedules, then future schedules, based on the number of calendar days specified in these fields. Schedules with due dates before the day specified in the Start of Week field are not considered.

This process stops when all available schedule quantities are consumed or all excess completions have been recorded against a schedule.

For schedules with due dates in the past, the Consume Back value also determines which open quantities planning functions such as Material Requirements Planning (MRP) consider as sources of supply.

*Start of Week.* Enter the day of the week for the system to use in coordination with the Consume Back value:

- When searching for exploded schedules with past due dates on which to record excess item completions
- To determine which open quantities on past schedules to consider as sources of supply in planning functions such as MRP

Valid values are Sunday–Saturday, Today, and None.

To ensure that all completions are recorded only against scheduled orders for the current week, you can define control program settings as follows:

- Set Start of Week to the first day of your company's business week (typically Monday).
- Set Consume Back to 7.
- Set Consume Forward to 0 (zero).

*Allow Zero Run Rate.* Specify whether item-level records defined in Production Line Maintenance can include a 0 (zero) value in the Units/Hour field.

**No (default):** The item Units/Hour defaults from the production-line run rate. The system always uses the item run rate when calculating schedules for the item. Although you can change the default, you cannot set it to 0.

**Yes:** The item Units/Hour defaults to 0. Unless you change it, the system uses the production line run rate when scheduling the item. Otherwise, it uses the specified non-zero item-level value.

Set the field to Yes to define a global run rate for all items on each production line. In Production Line Maintenance, you can then specify a Units/Hour value at the production-line level and leave all or most item-level fields set to 0. If individual items are exceptions, you can define item-specific run rates just for them.

## Simulating Schedules in the Workbench

Line Schedule Workbench (18.1.10) is exactly the same as the workbench (18.22.1.10) in Advanced Repetitive.

See “Simulating Schedules in the Workbench” on page 126.

## Creating and Exploding Repetitive Schedules

These functions are almost identical in the two modules. Internally, the system processes additional information for Advanced Repetitive schedules, but the interface and input values are the same.

See “Creating Repetitive Schedules” on page 129.

## Using Repetitive Picklists

Picklist Menu (18.3) functions are identical in both the Repetitive and Advanced Repetitive modules.

See “Using Repetitive Picklists” on page 131.

## Managing Cumulative Orders

Cumulative orders track repetitive activities in much the same way as in Advanced Repetitive. Cumulative orders can be added manually using Cumulative Order Maintenance (18.6). However, this function’s primary purpose is to change the status of an existing cumulative order to Closed so that Cumulative Order Accounting Close (18.9) can be used. Cumulative orders should remain open for the periods used by accounting to monitor WIP costs. Procedures should be in place to ensure they are closed at the end of each fiscal month or period.

See “Managing Cumulative Orders” on page 135.

## Executing Repetitive Transactions

Repetitive transactions provide feedback for repetitive operations. Like those in the Shop Floor Control module, they require use of an employee code. However, Repetitive Labor Transaction differs significantly from shop floor control transactions because it triggers inventory transactions to backflush components and receive completed units.

See Chapter 7, “Shop Floor Control,” on page 103.

## Operation Reporting

The reporting of setup hours, labor hours, downtime, reject quantities, rework quantities, and scrap quantities works much the same in Repetitive as in the Shop Floor Control module but with the following differences:

- The reason codes for nonproductive labor should use DOWNTIME instead of DOWN.
- Operation scrap can be reported in Repetitive but not in Shop Floor Control. Like the reporting of reject and rework quantities, scrap quantities have no impact on the general ledger and do not affect costing.
- Reports for reporting reject quantities are available in Repetitive.
- The Repetitive module includes some reports specific to that module.

## Repetitive Completions

When a routing has many operations, there may be a few that are used to report completions, called milestone operations.

### Milestone Operations

In Routing Maintenance (14.13.1), you can define any operation—including standard operations—to be a milestone. At a milestone operation, that operation and all previous non-milestone operations are backflushed when repetitive labor is reported. The last operation is always treated as a milestone.

The following rules govern reporting:

- You cannot report labor against a non-milestone operation.
- You can report setup, downtime, reject, and scrap against a non-milestone operation. However, this reporting does not affect WIP.
- If you report scrap or reject at a non-milestone operation, it will backflush at that operation.

If you do not report setup at non-milestone operations and report labor at milestone operations, the standard setup will be backflushed. If you report setup at the milestone operation, then no setup will be backflushed.

## Reporting Completions

Completed units are received into inventory when quantities are reported as complete for the last operation for an item, using Repetitive Labor Transaction (18.14). Components can be backflushed when completed units are received if the components are linked to the last operation.

**Note** For each change in the quantity complete at a milestone operation, the quantity complete at all of the previous non-milestone operations is changed to reflect the fact that the later operation was completed.

If completions are recorded on nonscheduled dates, the reporting of quantities on these dates causes entries to be automatically added to the repetitive schedule.

If you are using shipping groups and inventory movement codes, you can enter shipment information and generate shippers when items are backflushed. The system looks for a shipping group with matching addresses for the issuing and work order sites and with inventory movement codes that include ISS-WO.

See the Shipping chapter in *User Guide: QAD Sales* for details.

If you report completions for today's date using Repetitive Labor Transaction, the report has the following effects:

- Inventory is incremented by the completion amount. A backflush occurs. Component inventory is shown as issued to the repetitive order. The requirements for components at all previous non-milestone operations are decremented. Floor stock items are accounted for.
- If there is a scheduled amount for today, the quantity completed is incremented and the quantity open decremented until the scheduled quantity is reached. These quantities can be reviewed in Operation Schedule Report (18.2.5).
- If there are previous non-milestone operations, the quantity completed at each previous operation is also incremented, up to the amount required to make the scheduled amount of the finished item.
- If the quantity open at the last operation is still nonzero, indicating the quantity completed is less than the quantity scheduled, the quantity open is treated as supply by MRP, and shown as the current amount of the planned order in MRP Detail Inquiry (23.16). See Chapter 13, "Material Requirements Planning," on page 267.

The Consume Forward, Consume Back, and Start of Week settings in Repetitive Control (18.24) determine how the system handles item completions that exceed the quantity scheduled on a given day. For example, you may complete some items ahead of schedule or scrap fewer items than expected. When this occurs, the system follows these steps to record the excess completions against other exploded schedules:

- 1 The system searches for a scheduled order routing with a start and due date range that includes the effective date of the repetitive labor transaction. If the system finds scheduled order routings that meet this criterion, it applies the excess completions to their corresponding schedules, starting with the schedule that has a due date closest to the reporting transaction effective date.
- 2 If excess quantities still remain after the previous step has executed, the system subtracts the number of days specified in the Consume Back field from the reporting transaction effective date. It then searches for exploded schedules with due dates that are between this day and the effective date. Schedules with due dates that are before the day specified in the Start of Week field are not considered.

See "Defining Control Program Settings" on page 172.

Starting with the schedule that has the earliest due date, the system consumes open scheduled quantities until all available quantities are consumed or all excess completions have been recorded against a schedule.

**Note** When Start of Week is set to Today, the system does not consider the Consume Back value when searching for open schedule quantities to consume. Only the Consume Forward setting is used.

- 3 If excess quantities still remain after the system has consumed open quantities on past schedules, the system adds the number of days in the Consume Forward field to the reporting transaction effective date. It then searches for exploded schedules with due dates that are between this day and the effective date.

Starting with the schedule that has a due date closest to the transaction effective date, the system consumes open scheduled quantities until all available quantities are consumed or all excess completions have been recorded against a schedule.

When Consume Back and Consume Forward are both 0 (zero), the system simply transfers excess completed quantities to inventory and does not report them against a repetitive schedule. This also occurs when the system runs out of open schedule quantities to consume.

Completed planned orders are not considered by MRP.

## Repetitive Scrap Transaction

An item scrapped in the first operation may have a lower cost than one scrapped on receipt. It will not have the accumulated labor, burden, and additional material costs that accrue during subsequent operations.

Repetitive Scrap Transaction (18.18) reports scrap at the item's accumulated cost through the operation where it is scrapped. The system uses the standard cost created by the most recent use of Operation Cost Calculation (14.13.17). However, if no operation costs exist for the item/routing/cost set, Repetitive Scrap Transaction automatically rolls up and totals the material, labor, burden, and subcontract costs by operation. It also does this for scrap reported for alternate BOMs/routings not included in Operation Cost Calculation.

The item cost by operation can be reviewed using the Operation Cost Browse, (14.13.18) or the Operation Cost Report (14.13.19). After the scrap transaction is recorded, the scrap cost can be verified using the Repetitive Operations Accounting Report (18.4.10). Repetitive Scrap Transaction debits scrap and credits WIP for the operation cost multiplied by the quantity scrapped.

## Checking Component Availability

You can use the following component check browse collections for real-time retrieval of work order component availability, maintenance, manipulation, viewing, and reporting of production details:

- Release Production Orders by Production Line
- Manage Materials for Production Line
- Release Production Orders by Work Center
- Manage Materials for Work Center
- Monitor Material Shortages
- Purchase Direct Materials

The browse collections let you perform material component shortage checks across your selected range of work orders and order statuses. Since most manufacturers experience shortages, the component check programs let you quickly identify and analyze the shortage so that your orders can still be met.

The browse collections let you look at current and future component projected quantity on hand (PQOH) statuses. And the status check is automated in a single display, so there is no need to manually search through various reports, programs, and browses to check for shortages.

You can use the component check browse collections to drill down into component shortage information for selected jobs (work orders) to identify the root cause and possible solutions.

Your selection drives the data that displays in the details programs. An asterisk (\*) displays in the row of data within the detail programs that relates to your selection in other browse programs. This helps you trace data back to the record upon which you are calculating component availability; see Figure 9.2.

**Fig. 9.2**  
Data Trace

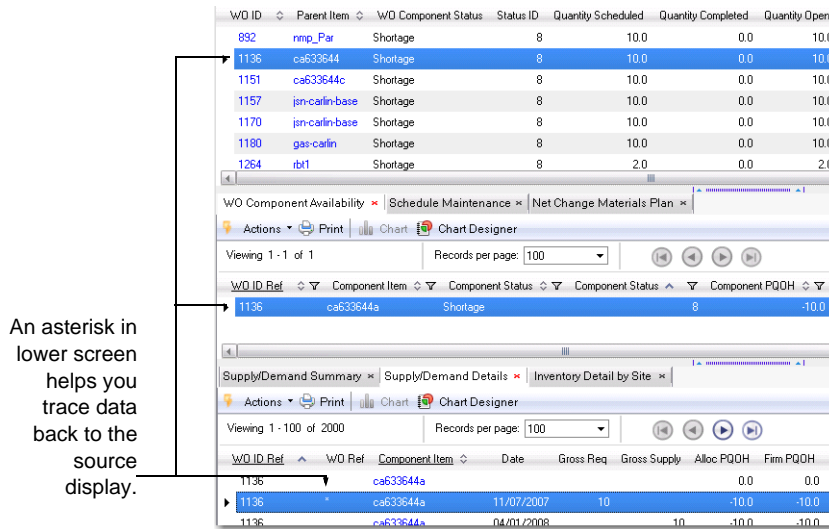

## Release Production Orders by Production Line

Release Production Orders by Production Line and Manage Materials for Production Line have the same program name (qpbr003.p). You use the two browse collections in conjunction to resolve production line shortages. Both pull in additional browses.

Production schedulers can use Release Production Orders by Production Line to quickly determine if the production schedule is viable for the day, week, month, or any specified time period. Release Production Orders by Production Line provides quick answers for production schedulers when they need to know the following:

- Before releasing a work order (WO) to the floor, are all components available?
- For production orders scheduled over the next one+ days, are there component shortages?

For repetitive production schedules, you can determine if there are material shortages, which components are short and by when, or whether you have enough supply coming in to meet future demand. This is accomplished with a time-phased component shortage engine that calculates availability and lets you view work order component status in terms of shortage severity. That is, you can easily determine which components have a shortage and the level of severity for the shortage.

Because the system provides a time-phased view of component supply and demand, you can know your supply and demand based on any given date, work order, or production line. You can:

- View production schedule data by any combination of site; production line or operation; item, due, or release dates; quantity complete, open, or ordered; and more.
- View both planned and scheduled orders associated with a production line.
- Identify which repetitive orders have material shortages related to them.
- Identify the components causing the shortage related to a repetitive order.
- Locate and determine the cause of material shortages.
- View in-transit supply in the form of ASN receipts.

Release Production Orders by Production Line includes the following programs and browses:

- Work Order Browse - Lists selected work orders along with component shortage severity status. The WO component status that displays is the most severe component status found among the components. The browse is located at the top of the screen.
- Work Order Component Browse - Lists work order components for a particular work order. Each component listed has a component shortage severity status associated with it. The browse is a child of the Work Order Browse, and located in the middle of the screen.
- Work Order Component Details - Contains Supply/Demand Detail and Supply/Demand Summary. The browses are located at the bottom of the screen.
- Supporting Business Process Browses and Programs - The default browse collection contains other supporting browses and programs. For example, Schedule Maintenance is provided so that you can quickly access and modify a scheduled quantity if a material shortage exists. Net Change Materials Plan is also provided so that you can view results once you change the schedule, make a net change, and explode a schedule.

### Example

As a Production Planner, you want to ensure that all work orders scheduled over the next week have enough components available. You run Release Production Orders by Production Line to look at work orders that have a release date during the next seven days. To do this, you set search criteria for work order release date for seven days away. You add secondary search criteria to find work order component status that contains a shortage.

The system displays all work orders with a status of 7 (Projected Shortage) or 8 (Shortage). You look at the Supply/Demand Summary Browse to see the cumulative supply and demand information for that work order component detail record. To get more information, you look at the Supply/Demand Detail Browse to view the MRP details the system used to calculate the work order component status.

You have several options to resolve the shortage. You can reschedule either supply or demand. For example, to reschedule supply you can reschedule a purchase order receipt if the component is purchased. Or, if the component is manufactured, you can reschedule a work order. To reschedule demand, you can reschedule a sales order or forecast demand.

**Note** The functions and programs described are the defaults; however, you can add other core system browse and maintenance programs that help you resolve shortage problems.

Once you make the change, you refresh the data in Work Order Browse to determine if the shortage no longer exists for the component.

## Manage Materials for Production Line

Materials personnel can use Manage Materials for Production Line to:

- Create material picklists
- Transfer materials to production line locations

Manage Materials for Production Line includes the following programs and browses:

- Production Order Component List
- Repetitive Picklist Calculation
- Repetitive Picklist Print
- Repetitive Picklist Transfer
- Repetitive Picklist Undo
- Repetitive Picklist Delete
- Supply Demand Summary
- Supply/Demand Details
- Transfer Single Item

## Release Production Orders by Work Center

Release Production Orders by Work Center and Manage Materials for Work Center have the same program name (qpbr005.p). You use the two browse collections in conjunction to resolve work center shortages. Both pull in additional browses.

Production schedulers can use Release Production Orders by Work Center to quickly determine component availability for discrete work orders for a particular work center. Checking components by work center lets production schedulers know if the production schedule is viable for the week. Release Production Orders by Work Center provides quick answers for production schedulers when they need to know the following:

- Before releasing a work order (WO) to the floor, are all components available?
- For production orders scheduled over the next one+ days, are there component shortages?

For discrete work orders, you can determine if there are material shortages, which components are short and by when, or whether you have enough supply coming in to meet future demand. This is accomplished with a time-phased component shortage engine that calculates availability and lets you view work order component status in terms of shortage severity. That is, you can easily determine which components have a shortage and the level of severity for the shortage.

Release Production Orders by Work Center includes the same supporting programs and browses that Release Production Orders by Production Line uses.

## Example

As a Production Planner, you want to ensure that all work orders scheduled over the next week have enough components available. You run Release Production Orders by Work Center to look at work orders that have a release date during the next seven days. To do this, you set search criteria for work order release date for seven days away. You add secondary search criteria to find work order component status that contains a shortage.

The system displays all work orders with a status of 7 (Projected Shortage) or 8 (Shortage). You look at the Supply/Demand Summary Browse to see the cumulative supply and demand information for that work order component detail record. To get more information, you look at the Supply/Demand Detail Browse to view the MRP details the system used to calculate the work order component status.

You have several options to resolve the shortage. You can reschedule either supply or demand. For example, to reschedule supply you can reschedule a purchase order receipt if the component is purchased. Or, if the component is manufactured, you can reschedule a work order. To reschedule demand, you can reschedule a sales order or forecast demand.

## Manage Materials for Work Center

Materials personnel can use Manage Materials for Work Center to:

- Create material picklists
- Transfer materials to work center locations

Manage Materials for Work Center includes the same supporting programs and browses that Manage Materials for Production Line uses, except that it also includes Inventory Detail by Site.

## Monitor Material Shortages

Monitor Material Shortages and Purchase Direct Materials Manage Materials have the same program name (qpbr006.p). You use the two browse collections in conjunction to resolve material shortages. Both pull in additional browses.

Materials Planners can use Monitor Material Shortages to quickly identify the components they manage and determine if there are shortages that impact production. Material managers or expeditors typically use this program to ensure that there are no component shortages for scheduled production orders. They can view a list of items and the jobs (work orders) that are impacted by item shortages. Having this information helps keep production running and expedites order processing.

The system calculates availability and lets you view item status in terms of shortage severity. That is, you can easily determine which items have a shortage and the level of severity for the shortage. Because you can view time-phased supply and demand, you can know your supply and demand based on any given item, date, or work order. You can:

- Select from a wide range of item attributes to include in the component monitoring, such as buyer/planner codes.
- Identify which items have component or material shortages related to them.
- Identify the work order to which the shortage is related.
- Locate and determine the cause of material shortages.

Use the Next Scheduled Receipt column to view dates of the next scheduled receipt of the item. You can use functions of Purchase Direct Materials Browse Collection to review or create purchases of the item. The column also shows you when authorized or scheduled receipts are delayed.

Monitor Material Shortages includes the same supporting programs and browses as Release Production Orders by Production Line except that it does not include Work Order Browse.

### Example

As a Materials Expediter, you want to ensure that you have enough components for all orders of an item. You want to start at the work order component level, accessing data by component item number. To do this, you set search criteria for buyer/planner ID to see items assigned to you. You add secondary search criteria to find items that contain a specific work order release date; then click Search. The system displays the component per your selection criteria.

**Note** To view only items with shortages, you can filter on a specific item status, such as Shortage, or you can include this as part of your browse selection criteria.

To get a summary of the issue, you then look at Supply/Demand Summary to determine the total source of the supply demand for this component. You then drill down into the details using the Supply/Demand Detail Browse, viewing projected QOH based on supply and demand by date.

You have several options to resolve the shortage. You can contact your company Sales Planner or Production Planner to reschedule either supply or demand. For example, to reschedule supply the planner can reschedule a purchase order receipt if the component is purchased. Or, if the component is manufactured, the planner can reschedule a work order. To reschedule demand, the planner can reschedule a sales order or forecast demand.

**Note** The functions and programs described are the defaults; however, you can add other core system browse and maintenance programs that help you resolve shortage problems. Once you make the change, you refresh the data in Work Order Browse to determine if the shortage no longer exists for the component.

### Displaying Components

Your purchased component may not display in Monitor Material Shortages Browse. When this happens, it is typically because:

- The browse is driven by work order demand records where an exploded BOM exists. An item/record only displays on the list when it is created by an exploded BOM record. If the purchased part demand is driven directly from a sales order, forecast, safety stock, and so on, the item/record does not display in the list.
- If the item belongs to a BOM of a make item but does not display on the browse, it is because you need to run CRP to explode the P(lanned) status work order to which this item belongs. Run CRP for planned orders to generate the exploded BOM.

## Purchase Direct Materials

Buyers or planners who are responsible for ensuring available material to support production can use Purchase Direct Materials to:

- Enable monitoring of planned orders.
- Generate purchase orders for direct material requirements.

Users of this browse collection are typically authorized to create discrete purchase orders, release blanket purchase orders, create supplier scheduled orders, and update supplier schedules with firm receipt requirements.

**Note** Materials expeditors who do not create purchase orders for direct materials can use the Monitor Material Shortages browse collection.

Purchase Direct Materials uses the following supporting programs and browses:

- Supply Demand Summary
- Supply/Demand Details
- Inventory Detail by Site
- Scheduled Order Browse
- Purchase Order Browse

## Decimal Places

In the component check browses, numbers display only a single digit after the decimal point—unlike typical system screens and reports that can display up to eight places after the point; for example, in component check browses, the system displays 1.1, not 1.111399.

To expand the decimal places, modify the format of the field in Browse Collection Maintenance. Changing the format does not impact calculations.

## System Security

System security can be set for any program or browse that has a menu entry. If the program or browse exists within one of the component check browse collections, the following security issues can exist:

- If you do not have access to either a program or the menu within which the program resides, you cannot access the program in a component check browse collection.

**Example** If you do not have access to Repetitive Schedule Maintenance in the Schedule Menu (18.2), but have access to it in the Advanced Repetitive Menu (18.22.2), the program is not be available to you in the component check browse collection.

- Of the browse components in the component check browse collections, only the top-level browses have menu entries and, therefore, can be secured.

## Component Check Calculations

The system calculates component availability for a work order component record by calculating projected quantity on hand (PQOH) using MRP supply and demand detail information. The calculation results display in two columns within the Work Order and Work Order Component Browsers:

- Component Status
- Status ID

**Fig. 9.3**  
Work Order Browse

W/O ID	Parent Item	W/O Component Status	Status ID	Quantity Scheduled	Quantity Completed	Quantity Open	Release Date	Due Date	W/O Status	Production Line	Primary Line	Site	
10	20001	Projected Shortage	7	10.0	0.0	10.0	01/10/2007	01/10/2007	F			1000	2006
892	rmc_Pir	Shortage	8	10.0	0.0	10.0	10/31/2007	10/31/2007	R				reqpsh
1090	418a	Projected Shortage	7	100.0	0.0	100.0	11/06/2007	11/06/2007	e	pace1			dkb
1100	418b	Projected Shortage	7	100.0	0.0	100.0	11/06/2007	11/06/2007	e	pace			dkb
1136	ca63344	Shortage	8	10.0	0.0	10.0	11/07/2007	11/07/2007	R				va431
1137	418c	Projected Shortage	7	100.0	0.0	100.0	11/07/2007	11/07/2007	e	dk			dkb
1140	622418	Projected Shortage	7	100.0	40.0	60.0	11/07/2007	11/07/2007	e	pace			10000

System-calculated shortage severity displays here.

The Component Status column displays a textual description of the status, while the Status ID column displays the numeric value of the severity. Status IDs can range from 1 to 8, with 8 being the highest severity. The following lists the possible Status IDs and associated Component Status:

- 1: No components. The work order does not have any components.
- 2: Issued complete. All materials have been issued for the work order component.
- 3: Available. Sufficient inventory is projected to be available for the work order component. This only includes nettable on-hand inventory. It does not include unconfirmed shipper receipts (for example, ASNs), scheduled receipts (for example, purchase orders) and planned receipts (that is, MRP planned work orders).
- 4: Unconfirmed shipper receipts. A PO shipper receipt was created but not confirmed (for example, goods may still be in transit). Sufficient inventory is projected to be available for the work order component. This includes nettable on-hand inventory and unconfirmed shipper receipts.
- 5: Scheduled receipts. Sufficient inventory is projected to be available for the work order component. This includes nettable on-hand inventory, unconfirmed shipper receipts, and scheduled receipts.
- 6: Planned receipts. Sufficient inventory is projected to be available for the work order component. This includes nettable on-hand inventory, unconfirmed shipper receipts, scheduled receipts, and planned receipts.
- 7: Projected shortage. There is insufficient inventory projected to be available for the work order component. This includes nettable on-hand inventory, unconfirmed shipper receipts, scheduled receipts, and planned receipts. This applies to work orders with status P(lanned), F(irm), B(atch) and E(xploded) only.
- 8: Shortage. There is insufficient inventory projected to be available for the work order component. Nettable on-hand inventory is not sufficient to cover requirements. This applies to work orders with status A(llocated) and R(eleased) only.

The system considers the status of a work order. Work orders can have a status of:

- (P)lanned
- (F)irm
- (B)atch
- (E)xploded
- (A)llocated
- (R)eleased

The system groups the work order statuses into three commitment categories when calculating component availability:

- Planned work orders are in the Plan category.
- Firm, Batch, and Exploded work orders are in the Firm category.
- Allocated and Released work orders are in the Release category.

## Demand Supply Browse

These categories correspond to the three PQOH columns that display in the Supply/Demand Detail Browse.

**Fig. 9.4**  
Supply/Demand Detail Browse, PQOH Columns

W/O ID	Ref	Component Item	Date	Gross Req	Gross Supply	Alloc PQOH	Firm PQOH	Plan PQOH	Source
1136		ca633644a				0.0	0.0	0.0	Beginning Available
1136	*	ca633644a	11/07/2007	10		-10.0	-10.0	-10.0	Work Order Component
1136		ca633644a	04/01/2008		10	-10.0	-10.0	0.0	Work Order

Columns correspond to WO  
commitment categories.

The system uses the commitment category to determine into which PQOH column it compiles the work order. Use the information in Supply/Demand Detail to view MRP supply and demand detail data for a component by date.

## Demand/Supply Summary Browse

There can be hundreds of MRP detail records for the component you select; but how do the records relate to the component of the work order you selected?

For a selected work order and work order component, the system collects and totals all MRP supply and demand records prior to, and including, the work order record you selected. You can see these aggregated records in the Supply/Demand Detail Browse.

The Supply/Demand Summary Browse lets you view the aggregated records from a matrix point of view:

- The first row in the display is the Supply Row. It lists the current QOH for the work order component item and other sources of cumulative supply up through the work order component's demand release date.
- The next three rows are Demand Rows. They list the three categories of demand. Each row starts with prior demand requirements and the gross requirements of the selected work order. Then from left to right, it adds in the current QOH, then adds in the cumulative supply to calculate the component PQOH.

This supply and demand matrix format provides you with a global view of component supply/demand.

**Fig. 9.5**  
Supply/Demand Summary

Supply added in, starting with current QOH.

W/O ID	Component Item	Type	Status	Net Avail/PQOH	Shipper Rcpt/PQOH	Scheduled Rcpt/PQOH	MRP Plan Rcpt/PQOH
1136	ca632644s	Supply		0.0	0.0	0.0	0.0
1136	ca632644s	Demand	Allocated	-10.0	-10.0	-10.0	-10.0
1136	ca632644s	Demand	FIRM	-10.0	-10.0	-10.0	-10.0
1136	ca632644s	Demand	Planned	-10.0	-10.0	-10.0	-10.0

Demand added in.

You can anticipate when a material shortage typically occurs in your production cycle to determine if your supply meets future demand. For example, if a material shortage typically occurs two to three days before a standard supplier delivery on the first of every month, you can factor in this anticipated shortage and view incoming supply to determine if the demand can be met.

Since you can view both planned and confirmed orders for short components, you can always take into account the worst-case items; that is, you can factor in orders, receipts, or work centers for items that take the longest time to process.

## Viewing Receipt Data

When drilling down to find the reason for shortages, you can view receipts. You can also view the expected receipt dates based upon the date of an Advance Ship Notice (ASN). Figure 9.6 shows an unconfirmed shipper receipt in supply.

**Note** The system consumes the unconfirmed ASN receipt quantities from scheduled and planned receipt quantities to avoid double-counting the receipt.

**Fig. 9.6**  
Unconfirmed Receipt

W/O ID	Parent Item	W/O Component Status	Quantity Completed	Quantity Open	Release Date	Primary Line
7464	A F100	Unconfirmed Shipper Rcpt	0.0	10.0	07/19/2008 A-100	Finished Product
7465	A F100	Unconfirmed Shipper Rcpt	0.0	20.0	07/20/2008 A-100	Finished Product
7466	A F100	Unconfirmed Shipper Rcpt	0.0	30.0	07/21/2008 A-100	Finished Product

If you click on the unconfirmed receipt, the system factors in the unconfirmed receipt. Click the refresh button to view results, shown in Figure 9.7.

**Fig. 9.7**  
Calculated Unconfirmed Receipt

WO ID	Component	Type	Status	Pick Gross Req	Gross Req	Net Avail/PQD	UnConf Shipper Rcpt/PQD	Scheduled Rctz/PQD	MRP Plan
7464	A-F140	Supply		0.0	0.0	0.0	0.0	0.0	0.0
7464	A-F140	Demand	Allocated	0.0	0.0	0.0	0.0	50.0	50.0
7464	A-F140	Demand	Repl	0.0	10.0	-10.0	0.0	50.0	50.0
7464	A-F140	Demand	Planned	0.0	0.0	-10.0	0.0	50.0	50.0

If you have planned orders only, you can see planned receipts, too.

**Fig. 9.8**  
Planned Receipts

WO ID	Parent Item	WO Component	Status	Quantity Completed	Quantity Open	Release Date	Primary Line
7465	A-F100	Unconfirmed Shipper Rcpt		0.0	30.0	07/20/2008	A-100 Finished
7474	A-F100	Unconfirmed Shipper Rcpt		0.0	30.0	07/27/2008	A-100 Finished
7475	A-F100	Planned Receipts		0.0	30.0	08/03/2008	A-100 Finished

You can rectify shortages by moving up receipts. Then, you can change the schedule in Schedule Maintenance, launched from the browse collection, then, optionally, rerun Net Change Materials Plan to clear any planned receipts. Finally, you refresh the top component availability portion of the screen to determine if this resolved the shortage.



# WIP Lot Trace

This chapter describes how to set up and use features of the WIP Lot Trace module (WLT).

***Overview of WIP Lot Trace*** 190

Describes the functions of the WIP Lot Trace, its attributes, and functions.

***Planning for WIP Lot Trace*** 195

Describes what to do and which issues to resolve to prepare.

***Setting Up WIP Lot Trace*** 199

Outlines how to set up a WIP Lot Trace.

***Working with WIP Lot Trace*** 205

Details minor modifications, specific needs, restrictions, functions, and case-specific aspects of the WIP Lot Trace.

***Reporting WIP Lot Trace Data*** 224

Contains details and tables about types of WIP Lot Trace Reports.

## Overview of WIP Lot Trace

The WIP Lot Trace (WLT) module lets you monitor and trace work in process (WIP) inventory at each operation in the manufacturing process easily and accurately. It facilitates tracking of WIP material lot/serials processed by multiple subcontractors and supports serial tracking of WIP material as needed. This module maintains detailed historical records, including which components produced a finished item and which finished items went to a customer.

WLT can be used in manufacturing environments supported by the Repetitive, Advanced Repetitive, or Work Orders modules. It adds WIP lot and serial tracing and reporting functions to manufacturing operations. Tracing records are created at the operation level whenever registered resources are consumed or produced.

Data recorded includes the lot numbers and optionally the serial numbers and references of:

- Component material consumed
- WIP material consumed
- WIP material scrapped
- WIP material produced
- Finished material produced

Cumulative WIP quantity-on-hand (QOH) balances are maintained for all traced lots and serials at each operation queue at the site/work center/machine location where the lot/serial resides.

While you can use this module to trace specific items throughout the manufacturing process, it can be used most efficiently to trace the component and WIP material consumed in the manufacturing of parent items. Use it to trace component, WIP material, and finished goods based on parent items, product structures, and routings.

### WIP Lot Trace and Regulatory Attributes

The WIP Lot Trace module and the Regulatory Attributes module trace material at different stages in the manufacturing process.

With Regulatory Attributes lot control, you trace inventory and the consumption of component material lots into finished-material lots. With WLT, you trace consumption of component material lots into WIP material lots, and the consumption of WIP and additional component material lots into finished-material lots.

The two modules can work together or individually. Performance is seamless when using one or both of these related, but different, modules. Each module requires separate setup and operation.

When using automatic lot numbering features of Regulatory Attributes, the finished item lot/serial number is automatically created when the item is moved into finished item inventory. Automatic lot numbering occurs even if you are using WLT. If you are not using automatic lot numbering, you can assign a new lot/serial number to the finished item or use the WIP lot/serial for the finished item.

See *User Guide: QAD Master Data*.

## Features

Using the WIP Lot Trace module, you can:

- Trace lot and serial numbers of WIP material throughout the manufacturing process, including WIP material processed by multiple subcontractors.
- Create flexible registrations to activate or deactivate WIP lot/serial tracking for all or specific BOMs, routing codes, parent items, component item, routings, and routing operations.
- Maintain complete WIP tracing history.
- Generate reports providing visibility of WIP lot/serial numbers and quantities.
- Optionally generate and assign WIP lot/serial numbers automatically using Number Range Management (NRM) features.
- Control the lot sizes for all traced material.
- Control combining and splitting of lot and component material being traced.
- Control the WIP inventory quantity-on-hand balances for WIP material lot/serials being traced.
- Trace component material lots consumed at any operation in a routing to WIP or finished material lots.
- Trace WIP material lots from operation to operation.
- Renumber lot/serials from one operation to the next, or retain the same numbers throughout all operations.
- Determine the constituent WIP or component material lots of finished or WIP material lots.
- Maintain up-to-date cumulative scrapped, consumed, and produced quantities for traced WIP lot/serials at the operation level.
- Maintain quantity-on-hand balances at the operation level for traced WIP lot/serials.

## Subcontract Processing Features

With WIP Lot Trace, you can track all subcontracted WIP material. With the subcontract tracing features, you can:

- Capture WIP lot/serial information and maintain quantity-on-hand balances for WIP material sent to multiple subcontractors.
- Print WIP lot numbers in subcontract shippers.
- Move WIP lots to subcontract operations during shipper confirm.
- Print WIP lot numbers on subcontract POs.
- Backflush subcontracted WIP lots as part of the PO receipts process.

## Changes to Other Modules

When activated, the WLT module adds a number of similar data collection frames and fields to the programs in the following modules:

- Inventory Control
- Purchasing
- Work Orders

- Shop Floor Control
- Repetitive
- Advanced Repetitive

WLT also modifies some reports and inquiries to include WLT information. Most frames function identically whenever they are used.

See “Working with WIP Lot Trace” on page 205.

## Inventory Control

Table 10.1 shows the Inventory Control programs affected by enabling the WIP Lot Trace module.

**Table 10.1**  
Inventory Control Programs Affected by WLT

Menu	Description	Program
3.4.3	Transfer With Lot/Serial Change	iclotr03.p
3.4.4	Batchload Transfer With Lot/Serial Change	iclotr04.p
3.21.1	Transactions Detail Inquiry	ictriq.p
3.21.25	Transactions Detail Report	NA <sup>1</sup>

1. Enhanced report; only available in .NET UI

## Purchasing

Table 10.2 shows the Purchasing programs affected by enabling the WIP Lot Trace module.

**Table 10.2**  
Purchasing Programs Affected by WLT

Menu	Description	Program
5.7	Purchase Order Maintenance	popomt.p
5.10	Purchase Order Print	poporp03.p
5.13.1	Purchase Order Receipts	poporc.p
5.13.7	Purchase Order Returns	porvis.p
5.13.13	PO Container Maintenance	rsctmt.p
5.13.14	PO Shipper Maintenance	rsshmt.p
5.13.20	PO Shipper Receipt	rsporc.p

## Work Orders

Table 10.3 shows the Work Orders programs affected by enabling the WIP Lot Trace module.

**Table 10.3**  
Work Orders Programs Affected by WLT

Menu	Description	Program
16.9	Work Order Split	wowosp.p
16.10	Work Order Component Issue	wowois.p
16.11	Work Order Receipt	woworc.p

Menu	Description	Program
16.12	Work Order Receipt Backflush	wowoisrc.p
16.19	Work Order Operation Backflush	wobkfl.p

## Shop Floor Control

Table 10.4 shows the Shop Floor Control programs affected by enabling the WIP Lot Trace module.

**Table 10.4**  
Shop Floor Programs Affected by WLT

Menu	Description	Program
16.20.1	Labor Feedback By Work Order	sfoptr01.p
16.20.2	Labor Feedback By Employee	sfoptr02.p
16.20.3	Labor Feedback By Work Center	sfoptr03.p
16.20.6	Operation Move Transaction	sfoptr06.p
16.20.7	Operation Scrap Transaction	sfscrap.p
16.20.13.8	Operation Transaction Browse	sfbr001.p
16.20.13.9	Operation Transaction Detail Inquiry	sfopiq12.p
16.20.13.13	Operations by Work Center Report	sfopr11.p
16.20.13.14	Operations by Work Order Report	sfopr12.p
16.20.13.15	Operations by Employee Report	sfopr13.p
16.20.13.33	Operation Transaction Detail Report	NA <sup>1</sup>

1. This enhanced report is available only in .NET UI.

## Standard Repetitive

Table 10.5 shows the standard Repetitive programs affected by enabling the WIP Lot Trace module.

**Table 10.5**  
Repetitive Programs Affected by WLT

Menu	Description	Program
18.4.2	Repetitive Transaction Detail Inquiry	reopiq12.p
18.13	Repetitive Setup Transaction	reoptr07.p
18.14	Repetitive Labor Transaction	reoptr10.p
18.16	Repetitive Rework Transaction	reoptr13.p
18.17	Repetitive Reject Transaction	reoptr11.p
18.18	Repetitive Scrap Transaction	reoptr14.p

## Advanced Repetitive

Table 10.6 shows the Advanced Repetitive programs affected by enabling the WIP Lot Trace module.

**Table 10.6**  
Advanced Repetitive Programs Affected by WLT

Menu	Description	Program
18.22.4.2	Operation Transaction Detail Inquiry	reopiq02.p
18.22.4.11	WIP Status Report	reworp05.p
18.22.5.4	Sub Container Maintenance	rectmt.p
18.22.5.5	Sub Shipper Maintenance	reshmt.p
18.22.5.9	Sub Shipper Print	rerp11.p
18.22.5.11	Sub Shipper Issue	resubis.p
18.22.5.13	Subcontract Scrap Maintenance	resscrap.p
18.22.10	Cumulative Order Close	reclose.p
18.22.12	WIP Status Inquiry	rewoiq05.p
18.22.13	Backflush Transaction	rebkfl.p
18.22.14	Run Labor Transaction	relbr.p
18.22.15	Setup Labor Transaction	reset.p
18.22.16	Reject Transaction	reject.p
18.22.17	Rework Transaction	rework.p
18.22.18	Scrap Transaction	rescrap.p
18.22.19	Move Transaction	remove.p
18.22.21	WIP Adjust Transaction	rewadj.p

## QOH and Cumulative WIP Balances

When the WIP Lot Trace module is active, some Repetitive, Advanced Repetitive, and Work Orders programs maintain WIP inventory and QOH balances by lot. QOH and WIP cumulative balance records are maintained for quantities scrapped, consumed, and produced for each lot processed at every traced operation.

**Table 10.7**  
Programs That Maintain WIP QOH Inventory Balances by Lot/Serial

Menu	Description	Program
5.13.1	Purchase Order Receipts	poporc.p
5.13.7	Purchase Order Returns	porvis.p
16.10	Work Order Component Issue	wowois.p
16.11	Work Order Receipt	woworc.p
16.19	Work Order Operation Backflush	wobkfl.p
16.20.1	Labor Feedback By Work Order	sfoptr01.p
16.20.2	Labor Feedback By Employee	sfoptr02.p
16.20.3	Labor Feedback By Work Center	sfoptr03.p
16.20.6	Operation Move Transaction	sfoptr06.p
16.20.7	Operation Scrap Transaction	sfscrap.p
18.14	Repetitive Labor Transaction	reopr10.p

Menu	Description	Program
18.16	Repetitive Rework Transaction	reopr13.p
18.17	Repetitive Reject Transaction	reopr11.p
18.18	Repetitive Scrap Transaction	reopr4.p
18.22.13	Backflush Transaction	rebkflmt.p
18.22.14	Run Labor Transaction	relbr.p
18.22.15	Setup Labor Transaction	reset.p
18.22.16	Reject Transaction	reject.p
18.22.17	Rework Transaction	rework.p
18.22.18	Scrap Transaction	rescrap.p
18.22.19	Move Transaction	remove.p
18.22.21	WIP Adjust Transaction	rewadj.p

## WIP Lot Trace Programs

WIP Lot Trace programs are located on the 3.22.13 menu. This module includes the following menu-level programs.

**Table 10.8**  
WIP Lot Trace Programs

Menu	Description	Program
3.22.13.1	Routing Registration Maintenance	wlrmmt.p
3.22.13.2	Routing Registration Inquiry	wlrmiq.p
3.22.13.4	BOM Registration Maintenance	wlbmmt.p
3.22.13.5	BOM Registration Inquiry	wlbmiq.p
3.22.13.13	WIP Lot Inventory Status Report	wlrp01.p
3.22.13.14	Item Lot Ship Transaction Report	wlrp04.p
3.22.13.15	WIP Lot Convert Transaction Report	wlrp06.p
3.22.13.16	WIP Lot Non-Convert Transaction Report	wlrp07.p
3.22.13.17	WIP Lot Inquiry	wliq01.p
3.22.13.18	Supplier Lot Transaction Report	wlrp08.p
3.22.13.19	WIP Lot Where-Used Report	wlrp02.p
3.22.13.20	WIP Lot Actual Bill Report	wlrp03.p
3.22.13.22	WIP Lot Browse	wlbr007.p
3.22.13.23	WIP Lot Delete/Archive	wldel.p
3.22.13.24	WIP Lot Trace Control	wlpm.p

## Planning for WIP Lot Trace

Setup of the WIP Lot Trace (WLT) module depends greatly on how much tracing your manufacturing environment requires. Having clearly defined tracing requirements simplifies the setup process.

This section discusses the issues you should resolve and the types of information that you should collect before you set up WLT. This information about your manufacturing environment will facilitate the setup and use of this module.

## Deciding Which Material to Trace

This module traces material based on parent item routing. Routings define where component items to be traced are consumed and where the WIP material to trace is produced. WLT also traces material based on parent item BOM codes when the component item is part of the BOM. Tracing does not occur on an item-per-item basis.

You should begin setup by first considering and listing which parent items need to have component and WIP material traced. From this list, derive the routings and BOMs used to manufacture the parent items. You need these routing and BOM codes to set up this module.

You should also note whether any special tracing requirements exist, such as operations in a routing where tracing should begin, or specific BOMs for which component items should not be traced. You should have this information prepared before you begin to set up WLT.

Knowing exactly which routings and BOMs consume components and create the WIP material you need to trace lets you configure the WIP Lot Trace module effectively. This is because you can configure the module to trace components and WIP for all routings and BOMs, with the exception of only a few, or you can configure it to trace components and WIP for only a few routings and BOMs.

## Milestone and Non-Milestone Operations

WLT cannot be used to track WIP material at non-milestone operations. WIP lot/serials are produced only by milestone operations. Additionally, WIP quantity-on-hand (QOH) balances cannot reside in the input queue of the first milestone operation of any routing. This is true even if the first milestone operation is not the first operation in the routing.

To track WIP material, including the component material consumed and parent items produced, routing operations that consume and produce that material must be milestone operations. Use Routing Maintenance (14.13.1) to update routings for use with WLT.

## Before Tracing Subcontracted WIP Material

If you plan to trace WIP material at multiple subcontractor locations, you should follow these steps before beginning to set up WLT:

- Create and plan to maintain detailed records of subcontractors qualified to perform each operation. You should note whether they maintain the WIP lot/serial numbers you assign or if they assign new ones for the material they process for you. For example, you send WIP lot AA to one of your subcontractors and the subcontractor later sends you the processed material with a new lot number.
- List all your subcontractors. Use Work Center Maintenance (14.5) to create a work center for each subcontractor.
- Use Routing Maintenance (14.13.1) to create or modify existing routing codes that have subcontracted operations. These routings should reference an appropriate subcontractor work center.

## Lot Sizing Restrictions

With WIP Lot Trace, you can restrict the size of lots processed by a routing or routing operation. Lot-size restrictions are useful when work centers can process only certain quantities of material, or when specific operations require certain lot sizes. For example, if machine capacity lets you produce only 50 items at operation 30, then the maximum lot size would be 50.

If any lot-sizing restrictions apply in your manufacturing environment, you should list these restrictions, organized by routing, operation, and work center. It is very important to note any lot-size restrictions that differ at operations within the same routing.

The lot-size information you collect facilitates configuring the WIP Lot Trace module. You use it to create records in Routing Registration Maintenance (3.22.13.1) that limit the size of lots processed by a routing or routing operation.

## Inventory Lot Quantity Issuing Restrictions

Some manufacturing environments allow WIP inventory quantities to be driven negative by overissuing of material; others do not. WIP inventory is the amount of WIP material that resides at an operation. If these types of restrictions apply in your manufacturing environment, sort them by routing. Then sort any restrictions within each routing by operation.

**Example** You have WIP lot 5A with 50 items at operation 30 of routing 101. At operation 40, you issue WIP lot 5A with 100 items. This issue would result in an overissue of 50 items, giving you a negative WIP QOH of 50 items at operation 30. You note that for routing 101, overissuing of WIP is allowed.

Use the information you collect regarding issuing restrictions to create records in Routing Registration Maintenance (3.22.13.1) that prevent or allow WIP lot overissuing based on the routing or routing operation.

## Inventory References

In addition to tracing component and WIP lot/serials, use this module to trace component lot inventory references.

**Example** Lot 3A of steel wire comes in three spools. Each spool is separately identified in inventory using the Reference field as Sp1, Sp2 and Sp3. When consuming steel wire in manufacturing, enter the spool number in the Reference field during backflush. The inventory references are recorded in tracing history records. WLT reports that display references show the spool reference consumed into each finished item.

If inventory reference tracing is required in your manufacturing environment, you should first set up naming and usage standards for references. References are not validated within the system, but a clearly defined system facilitates data entry and reporting during and after manufacturing processes.

**Note** You must trace component material in order to trace references.

## Lot Splitting and Combining

WIP Lot Trace manages lot splitting and combining.

- Lot splitting occurs when processing a single material lot at an operation results in two or more output lots.
- Lot combining occurs when two or more input lots are combined at an operation, resulting in one output lot.

If lot splitting or combining is an issue in your environment, clearly define your requirements. Consider whether you have a single requirement—you can or cannot split or combine lots, or multiple requirements—you can split or combine some lots, but not others. List these requirements by routing code and note any requirements that differ within each routing by operation.

**Example** Routing 101 has five operations. Operation 30 can only process lots of 50 items. The lots produced by operation 20 consist of 100 items. This requires that lots of 100 be split into two new lots of 50 items each. All operations after operation 30 continue to process 50-item lots. You note in routing 101 that lot splitting is allowed for operation 30.

Allowing lots to be combined should be carefully considered. As lots are combined through the manufacturing process, quality control risks become greater and more expensive. For example, if you combine lots at an early operation and later determine that the material from one of those lots is defective, you may need to rework or scrap all WIP material and finished material that was manufactured with the defective material. The more lot combining that occurs, the more material is affected in this manner.

When you complete your analysis, use this information to create records in Routing Registration Maintenance (3.22.13.1) and BOM Registration Maintenance (3.22.13.4). The system uses these records to allow or restrict splitting and combining of WIP and component material lots.

## Custom Lot/Serial Number Formats

If you have specific lot/serial number format requirements, create Number Range Management (NRM) sequence IDs using Number Range Maintenance (36.2.21.1). You can use one NRM sequence ID to generate all lot/serial numbers for WIP Lot Trace. Optionally, you can designate specific NRM IDs for individual routing codes.

See *User Guide: QAD System Administration*.

**Note** WLT requires that NRM-generated numbers be no longer than 18 characters. Generated lot/serial numbers are not checked against existing manually entered or NRM-generated lot/serial numbers.

## Maintaining Accurate System Configuration Information

In environments where strict tracing records are kept, such as manufacturing of pharmaceuticals, you should maintain detailed and dated records of control program settings, routing registration records, and BOM registration records. These records are important for product recall and for quality assurance.

You should also set up procedures like the following to help you record and regulate any changes to these WLT control settings.

- Consider defining designated roles with permissions to WLT control programs.

- Maintain an external system where you can record any control changes. This might be a simple spreadsheet, or an automated data-mining utility that records any control changes automatically.
- Avoid making manual changes to routing or BOM registrations. Instead, you should use the registration start and end dates to manage changes.

**Example** When lot/serial number formats change, create a WLT routing registration with the new NRM ID. Set the effective date for the new registration to a date immediately following the effective end date of the registration being changed. When a change needs to be expedited, change the effective end date of the registration being changed to correspond with the new registration's start effective date.

In addition to control records, you should also create, maintain, and adhere to a delete/archive schedule for all WLT historical information. Set up procedures that let you maintain correct and accurate historical tracing records that have been deleted from your system and archived elsewhere. Consider setting up procedures that let you easily locate and extract tracing records from archived tracing records.

## Setting Up WIP Lot Trace

Setting up WLT involves the same process whether you are using the Repetitive, Advanced Repetitive, or Work Orders module.

**Fig. 10.1**  
WIP Lot Trace Setup Workflow

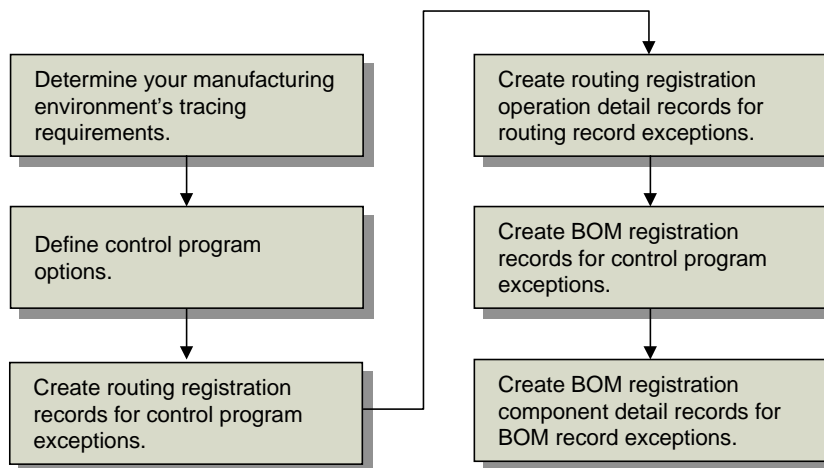

## Defining Control Program Settings

To begin setting up WIP Lot Trace, activate it by setting Enable WIP Lot Trace to Yes in WIP Lot Trace Control (3.22.13.24).

**Fig. 10.2**  
WIP Lot Trace Control (3.22.13.24)

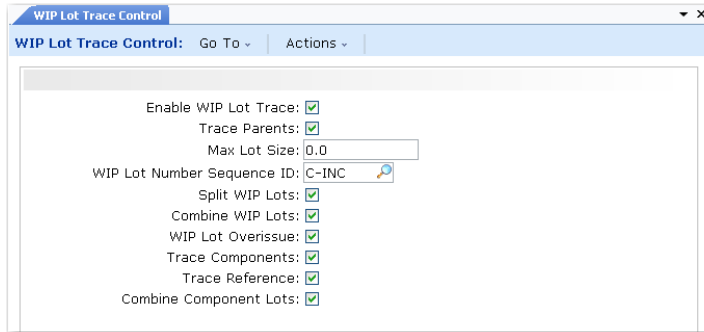

Control program settings apply to all routings and BOMs used throughout your manufacturing environment. Specify the most common BOM and routing settings in the control program. These values depend greatly on the information you collected when planning how you will use WLT.

See page 202 and page 204.

You can create exception records to override these settings for specific routings and BOMs. For example, in an environment where most parent items are traced, the Trace Parents value is set to Yes. To disable tracing for specific parent items that do not need it, use Routing Registration Maintenance to create a record for each of those parent items. Set the Trace Parents value to No for those records.

Use the following field descriptions and any data you collected as discussed in the planning section to guide you through the control program setup.

*Enable WIP Lot Trace.* Enter Yes to activate the WIP Lot Trace module.

When WIP Lot Trace is active, new fields and frames display in programs such as Backflush Transaction, Reject Transaction, and Rework Transaction.

See page 191.

*Trace Parents.* Enter Yes to trace all parent items; otherwise, enter No.

You cannot trace components or references unless Trace Parents is Yes in the control program or for the routing.

This value defaults to Trace Parents in Routing Registration Maintenance.

*Max Lot Size.* Enter the maximum size for WIP lots produced at any operation. A warning message displays when the cumulative WIP lot size exceeds this quantity.

Enter 0 (zero) to indicate that lot size is not restricted and to prevent warning messages from displaying.

This value defaults to Max Lot Size in Routing Registration Maintenance.

*WIP Lot Number Sequence ID.* Enter an optional sequence ID defined with Number Range Maintenance (36.2.21.1). The system uses this sequence to generate output WIP lot/serial numbers automatically.

NRM-generated WIP lot/serial numbers cannot exceed 18 characters.

This value defaults to WIP Lot Number Sequence ID in Routing Registration Maintenance.

If an NRM sequence is not specified, you must manually enter output WIP lot/serial numbers. However, when an NRM sequence ID is specified in WIP Lot Trace Control or in the routing registration record, you can leave the fields blank. The system automatically generates a lot/serial number based on this sequence ID.

*Split WIP Lots.* Enter Yes if an input WIP lot can be divided into multiple output WIP lots.

**Example** One WIP lot of blank bolt studs goes into a threading machine. The lot being consumed should not be split into separate output WIP lots, such as one lot of metric-thread bolts and one lot of standard-thread bolts. To prevent lot splitting, enter No.

This value defaults to Split WIP Lots in Routing Registration Maintenance.

*Combine WIP Lots.* Enter Yes if multiple input WIP lots can be combined into a single output WIP lot.

**Example** At operation 20, input WIP lot L1 is consumed into output WIP lot M1 using the backflush transaction. On the next backflush, you try to consume input WIP lot L2 into output WIP lot M1. If Combine WIP Lots is No, the second backflush transaction cannot proceed.

This value defaults to Combine WIP Lots in Routing Registration Maintenance.

*WIP Lot Overissue.* Enter Yes if a quantity can be issued for a WIP lot even when that issue results in a negative WIP lot quantity on hand (QOH).

**Example** With a WIP lot/serial QOH of 5, the system lets you issue a quantity of 7 when WIP Lot Overissue is Yes. A warning tells you that this issue will result in a negative QOH balance of -2. If WIP Lot Overissue is No, the system displays an error message. This situation can occur when a later operation is reported before an earlier one.

This value defaults to WIP Lot Overissue in Routing Registration Maintenance.

*Trace Components.* Enter Yes to trace component lots consumed in manufacturing operations; otherwise, enter No.

To trace component lot/serials, you must also trace their corresponding parent items.

This value defaults to Trace Components in BOM Registration Maintenance.

*Trace Reference.* Enter Yes to trace references assigned to traced component-item inventory.

To trace inventory references, you must also trace their corresponding component and parent items.

**Example** Lot 3A of steel wire comes in three spools. Each spool is separately identified in inventory using the Reference field as Sp1, Sp2, and Sp3. When steel wire is consumed, you must enter the spool number in the Reference field during backflush. If Trace Reference is Yes, the spool numbers are recorded in tracing history and display in the Lot Where Used and Lot Actual Bill reports. They also appear in transaction detail reports and inquiries.

This value defaults to Trace Reference in BOM Registration Maintenance.

*Combine Component Lots.* Enter Yes if multiple lots of the same component or raw material can be consumed into a single WIP lot/serial.

**Example** Combine Component Lots is No for steel. Two lots of steel, lot A and lot B, are in the storeroom. Lot A is processed at the first operation, becomes WIP lot W1, and is backflushed accordingly. If you try to backflush steel lot B into WIP lot W1, the system displays an error. Only one lot of steel can be consumed into WIP lot W1.

This value defaults to Combine Component Lots in BOM Registration Maintenance.

## Registering Routing Exceptions

Use Routing Registration Maintenance (3.22.13.1) to define exceptions to the control program settings by creating new settings for parent item routings and routing operations that need different values than those defined in the control program.

**Example** In WIP Lot Trace Control you indicate that the maximum WIP lot size is 150 because, in general, lot sizes must stay below this quantity in your manufacturing operations. However, for routing 007, you do not want the WIP lot size to exceed 50. Use Routing Registration Maintenance to specify this maximum lot size for routing 007.

**Fig. 10.3**  
Routing Registration Maintenance (3.22.13.1)

The screenshot shows the 'Routing Registration Maintenance' window. The fields and their values are as follows:

- Routing Code: 1002
- Start Date: 02/26/2007
- Trace Parents:
- Max Lot Size: 50.0
- WIP Lot Number Sequence ID: (empty)
- Split WIP Lots:
- Combine WIP Lots:
- WIP Lot Overissue:
- Lot Trace Start Op: 0
- Serialized WIP Start Op: 99999
- End Date: (empty)

Some field values default from the control program. Additional fields are described below. Use these descriptions and any data you collected as discussed in the planning section to register control program exception records for specific routings and routing operations.

**Routing Code.** Enter the routing code for which you are creating a routing registration record.

**Start Date.** Enter the date when this routing registration record is effective. When a start date is not specified, this registration record becomes effective immediately.

When multiple registration records have overlapping effective dates, the registration with the start date closest to the transaction effective date is used.

**Lot Trace Start Op.** Enter the operation where WIP lot tracing should begin for the specified routing code. The default is 0 (zero). Leave this value to begin WIP lot tracing at the first operation in this routing.

Any component material consumed at operations prior to the operation specified here is not traced. The system does not prompt for input WIP lots at this operation. It prompts for input and output WIP lots at the operations that follow.

**Serialized WIP Start Op.** Enter the operation at which serial tracing should begin. WIP serial tracing cannot begin before WIP lot tracing begins. It must begin on or after the operation specified in Lot Trace Start Op.

Leave the default value of 99999 to indicate that serial tracing should not occur.

For WIP lots to be serial traced, transaction quantities can only be -1, 0, or 1, and WIP lot quantity-on-hand (QOH) balances must be 0 or 1.

**Example** For a manufacturer of a pharmaceutical, serial tracing begins at the bottling operation, but WIP lot tracing begins at the first operation where lot-controlled ingredients are consumed. For a manufacturer of specialized components for medical equipment, serial tracing begins at the first operation that consumes a serial-controlled component.

**End Date.** Enter the last date that this routing registration record is effective. Leave blank to indicate that this registration should be effective indefinitely.

Once routing defaults are set, you can further define whether to allow lot splitting, combining, and overissuing per operation in the defined routing. This is done in the second frame of this program.

**Fig. 10.4**  
Routing Registration Operation Frame

**Operation.** Enter the operation for which you are creating a routing operation registration record.

**Split WIP Lots.** Enter Yes if WIP lots produced by this operation can be divided into multiple lots by the next operation.

This value only affects WIP material produced by this operation.

**Example** Because Split WIP Lots is No for operation 30, WIP lots produced by operation 30 cannot be split at operation 40. One WIP lot of blank bolt studs produced by operation 30 goes into a threading machine at operation 40. The lot to be consumed at operation 40 cannot be split into separate WIP lots, such as one WIP lot of metric-thread bolts and one WIP lot of standard-thread bolts. To allow lot splitting, set this field to Yes.

This value defaults from the first frame.

**Combine WIP Lots.** Enter Yes if multiple input WIP lots for this operation can be combined into a single WIP output lot before being processed by the next operation.

This value only affects WIP material produced by this operation.

**Example** Because Combine WIP Lots is No for operation 30, WIP lots produced by operation 30 cannot be combined at operation 40. Two WIP lots of blank bolt studs produced by operation 30 go into a threading machine at operation 40. The lots to be consumed at operation 40 cannot be combined into a single WIP lot. To allow lot combining, set this field to Yes.

This value defaults from the first frame.

**WIP Lot Overissue.** Enter Yes if a quantity can be issued for a WIP lot even when that issue results in a negative WIP lot quantity on hand (QOH) at this operation. This value defaults from the first frame.

This value only affects WIP material produced by this operation.

This value affects the output queue of this operation and the input queue of the following operation. When the output queue of the current operation is driven negative by a backflush at the following operation, the system must also allow for the input queue of the following operation to be driven negative.

**Example** A routing has 10 operations. In this manufacturing environment, the output of operation 5 must be allowed to have negative WIP lot balances. A backflush at the next operation consumes from its input queue as well as from current operation's output queue. For this reason, the input queue of the following operation must also be allowed to have negative WIP balances.

To do this, set WIP Lot Overissue to No in the first frame, indicating that for this routing registration record, WIP lot balances cannot be negative. In the second frame, specify Operation 5 and set WIP Lot Overissue to Yes. The value you set for operation 5 overrides the general routing value set in the first frame.

## Registering BOM Exceptions

BOM Registration Maintenance (3.22.13.4) is similar to Routing Registration Maintenance. Use this program to create exceptions to the control program settings by creating new settings for BOMs.

**Example** In WIP Lot Trace Control you indicate No in Trace Reference because you typically do not trace inventory references in your manufacturing operations. However, for BOM code 007 you need to trace references. Use BOM Registration Maintenance to indicate that references need to be traced for BOM 007.

**Fig. 10.5**  
BOM Registration Maintenance (3.22.13.4)

Some field values default from the control program. Additional fields are described below. Use the following field descriptions and any data you collected as discussed in the planning section to register control program exception records for specific BOMs or BOM components.

**BOM Code.** Enter a BOM code for which you are creating a registration record.

**Start Date.** Enter the date when this BOM registration record is effective. When a start date is not specified, this registration is effective immediately. When multiple registration records have overlapping effective dates, the registration with the most recent start date is used.

**End Date.** Enter the last date that this BOM registration record is effective. Leave blank to indicate that this registration should not end.

Optionally, use the second frame to further define whether to trace components or references and whether to allow combining of component lots for specific component items in the BOM.

**Fig. 10.6**  
BOM Registration Component Item Detail Frame

The screenshot shows a rectangular window titled 'BOM Registration Component Item Detail Frame'. Inside the window, there are four lines of text, each followed by a control element:

- 'Component Item:' followed by a text input field and a magnifying glass icon.
- 'Trace Components:' followed by a checkbox.
- 'Trace Reference:' followed by a checkbox.
- 'Combine Component Lots:' followed by a checkbox.

**Component Item.** Enter the component for which you are creating a detail BOM-registration record.

In the first frame of this program, you set up control fields that apply to all components of the specified BOM. In this frame, you can override these settings for specific components.

**Trace Components.** Enter Yes to trace lots of this component consumed in manufacturing operations; otherwise, enter No. To trace component items, you must also trace their corresponding parent items.

When Trace Components is Yes in WIP Lot Trace Control but this field is No, tracing does not occur when this component is consumed under this BOM code.

This value defaults from the first frame of this program. Changes you make here override the value set in the first frame for this component item in this BOM code only.

**Trace Reference.** Enter Yes to trace references assigned to lots of this component item.

To trace references, you must also trace corresponding component and parent items.

**Example** Lot 3A of steel wire comes in three spools. Each spool is separately identified in inventory using the Reference field as Sp1, Sp2, and Sp3. When steel wire is consumed, you must enter the spool number in the Reference field during backflush. If Trace Reference is Yes, the spool numbers are recorded in tracing history and display in the Lot Where Used and Lot Actual Bill reports. They also display in transaction detail reports and inquiries.

This value defaults from the first frame of this program. Changes you make here override the value set in the first frame for this component item in this BOM code only.

**Combine Component Lots.** Enter Yes if multiple lots of this component can be consumed into a single WIP lot/serial.

Combine Component Lots is No for steel. Two lots of steel, lot A and lot B, are in the storeroom. Lot A is processed at the first operation, becoming WIP lot W1, and is backflushed accordingly. If you try to backflush steel lot B into WIP lot W1, the system displays an error. Only one lot of steel can be consumed into WIP lot W1.

This value defaults from the first frame of this program. Changes you make here override the value set in the first frame for this component item in this BOM code only.

## Working with WIP Lot Trace

Before you begin using WLT, you should note that some order processing procedures are slightly modified to support WLT data entry. Additionally note that:

- WIP material cannot be traced at non-milestone operations.
- WIP lot/serial balances can reside only at milestone operations.
- Some normally editable fields are not editable. Instead, WLT frames are used to record that information.

- WIP quantity-on-hand (QOH) balances cannot reside in the input queue of the first milestone operation, even if the first milestone operation is not the first operation.
- Any information entered in WLT frames is used to update QOH balances and WLT tracing history records.
- Before processing any WLT-modified transactions, the system checks for associated WLT routing or BOM registrations that include lot splitting, combining, and size restrictions. If none are found, the system then looks for related restrictions in WIP Lot Trace Control.

## Using WLT Data Collection Frames

Depending on your particular tracing needs and system configuration, various Repetitive, Advanced Repetitive, Work Orders, Shop Floor Control, and Purchasing programs use WIP Lot Trace frames to collect, record, and update tracing records. The following sections discuss when these frames are activated and how they are used within each program.

Routing and routing operations become WLT controlled when:

- Trace Parents is Yes in WIP Lot Trace Control (3.22.13.24) and a routing registration does not exist for the routing being used. All operations for that routing become WLT controlled.
- A WLT routing registration is active for the routing. WLT control begins at the start operation specified in the registration record.

A component item becomes WLT controlled when it is consumed at a WLT-controlled operation and either of the following is true:

- Trace Components is Yes in WIP Lot Trace Control, or
- Trace Components is Yes in WLT BOM registrations for any BOMs that use the component.

## Destination Work Center and Machine

The Destination Work Center and Machine frame appears in Repetitive, Advanced Repetitive, and Work Orders programs. Use it to specify where to move the WIP material produced at the current operation. The information entered in this frame is used to update QOH balances for the affected queues.

**Example** In your Advanced Repetitive environment you have three machines in a work center that do the same job for operation 30. To trace WIP material processed by a machine, backflush the WIP material at operation 20 and use this frame to specify the machine where that WIP material will be processed during operation 30.

**Fig. 10.7**  
Destination Work Center and Machine Frame

When using Reject Transaction (18.22.16), this frame appears only when the reject-from queue is WLT controlled. When using Rework Transaction (18.22.17), this frame appears only when the rework-from queue is WLT controlled. For all other programs, this frame appears when:

- The current operation output queue is WLT controlled.

- The current operation is not the last operation.
- Move To Next Op is Yes.

Table 10.9 lists the material transfer programs that use this WLT frame.

**Table 10.9**  
Programs Displaying Destination Work Center and Machine Frame

Menu	Program
16.19	Work Order Operation Backflush
16.20.1	Labor Feedback by Work Order
18.14	Repetitive Labor Transaction
18.16	Repetitive Rework Transaction
18.22.13	Backflush Transaction
18.22.16	Reject Transaction
18.22.17	Rework Transaction
18.22.19	Move Transaction

### WIP Lot Input Queue Issue Data

Use the WIP Lot Input Queue Issue Data frame to register lot/serials of the WIP material being consumed at the current operation. This frame appears when the previous operation's output queue and the current operation's input queue are WLT controlled. Table 10.10 lists the programs where this frame appears.

**Table 10.10**  
Programs Displaying WIP Lot Input Queue Issue Data Frame

Menu	Program
5.13.1	Purchase Order Receipts
5.13.14	PO Shipper Maintenance
5.13.20	PO Shipper Receipt
16.10	Work Order Component Issue
16.19	Work Order Operation Backflush
18.14	Repetitive Labor Transaction
18.17	Repetitive Reject Transaction
18.22.13	Backflush Transaction

If the current operation's output queue is WLT controlled, these WIP lot/serials default to the WIP Lot Output Queue Receipt Data frame, (Figure 10.9). That output frame appears immediately after this input frame.

**Fig. 10.8**  
WIP Lot Input Queue Issue Data

WIP Lot Input Queue Issue Data - Qty Processed: 15 EA

Lot/Serial	Ref	Quantity
L1		2.0
Lot/Serial	Ref	Quantity
L1		<input type="text" value="2.0"/>

The current operation’s WIP QOH balances are updated to reflect the issue or receipt of this WIP material. The WIP lot/serials entered are recorded in tracing history as being consumed from the input queue of the current operation and produced into the output queue WIP lot/serials entered in the WIP Lot Output Queue Receipt Data frame.

**WIP Lot Output Queue Receipt Data**

Use the WIP Lot Output Queue Receipt Data frame to report the WIP lot/serial numbers, references, and quantities of the WIP material produced by an operation.

This frame appears in:

- Purchase Order Receipts (5.13.1) when the output queue of the current operation is WLT controlled.
- Repetitive Labor Transaction (18.14) when the output queue of the current operation is WLT controlled and is not the last routing operation.
- The programs listed in Table 10.11 if the previous two conditions are true, and only one lot/serial was entered.

If the current input queue is WLT controlled, the WIP lot/serial entered in the Input Queue WIP Lot Issue Data frame defaults to this frame. Assign this lot/serial, or assign a new one to the WIP material being produced.

**Fig. 10.9**  
WIP Lot Output Queue Receipt Data



For Advanced Repetitive, the total processed is the number entered in Qty Processed. This total includes the reject and scrap quantities. For Repetitive, the quantity processed is the number entered in Qty Completed. This quantity does not include scrap or reject quantities.

**Table 10.11**  
Programs Displaying WIP Lot Output Queue Receipt Data Frame

Menu	Program
5.13.1	Purchase Order Receipts
16.19	Work Order Operation Backflush
16.20.1	Labor Feedback by Work Order
16.20.2	Labor Feedback by Employee
16.20.3	Labor Feedback by Work Center
18.14	Repetitive Labor Transaction
18.22.13	Backflush Transaction

## Reporting Reject Data

Use the WIP Lot Reject Data frame to report the WIP lot/serial numbers, references, reject codes, and quantities of rejected material. The quantity is moved from the operation's output queue to the reject queue.

**Fig. 10.10**  
WIP Lot Reject Data

Lot/Serial	Ref	Code	Quantity
L5		Defect	5.0

Work Center: 12000      Machine:      General # 2  
 Department: 10      General  
 Qty Processed: 5.0      UM: EA      Conversion: 1.0000  
 Qty Scrapped: 0.0      Reason Code:      Multi Entry:   
 Qty Rejected: 5.0      Reason Code:      Multi Entry:

Lot/Serial	Ref	Code	Quantity
L5		Defect	5.0

This frame appears in the following programs when the output queue of the operation for which labor is being reported is WLT controlled and a quantity is entered in Qty Reject:

- Backflush Transaction (18.22.13)
- Repetitive Labor Transaction (18.14)
- Reject Transaction (18.22.16)
- Repetitive Reject Transaction (18.17)

## Reporting Scrap Data

Four WLT frames are used to record lot/serials, references, scrap codes, and quantities of WLT-controlled material being scrapped from an operation's input, output, or reject queues:

- WIP Lot Scrap Data
- WIP Lot Reject Queue Scrap Data
- WIP Lot Input Queue Scrap Data
- WIP Lot Output Queue Scrap Data

### WIP Lot Scrap Data

Backflush Transaction (18.22.13) uses this frame when the output queue of the operation for which labor is being reported is WLT controlled and a quantity is entered in Qty Scrapped.

**Fig. 10.11**  
WIP Lot Scrap Data

Lot/Serial	Ref	Code	Quantity
L5		Quality	3.0

Routing: WLT0-PI      Bom Code: WLT0-PI      10: 100  
 Work Center: 12000      Machine:      General # 2  
 Department: 10      General  
 Qty Processed: 15.0      UM: EA      Conversion: 1.0000  
 Qty Scrapped: 3.0      Reason Code:      Multi Entry:   
 Qty Rejected: 0.0      Reason Code:      Multi Entry:

The quantity scrapped is deducted from the lot quantity entered in the WIP Lot Output Queue Receipt Data frame. It is added to the cumulative scrapped quantity.

WIP Lot Reject Queue Scrap Data

Use the WIP Lot Reject Queue Scrap Data frame to record WIP material being scrapped from an operation’s reject queue. This frame displays in Scrap Transaction (18.22.18) when a reject quantity is entered in Rjct Queue and the reject queue is WLT controlled. It also displays in Repetitive Scrap Transaction (18.18).

**Fig. 10.12**  
WIP Lot Reject Queue Scrap Data

Prod Op	Lot/Serial	Ref	Code	Quantity
20	L5		Quality	3.0

Work Center: 12000      Machine:      General # 2  
 Department: 10      General  
 To Queue: EA      Conversion: 1.0000  
 In Queue: 0.0      From Queue:      Multi Entry:   
 Out Queue: 0.0      Reason Code:      Multi Entry:   
 Reject Queue: 3.0      Reason Code:      Multi Entry:

Prod Op	Lot/Serial	Ref	Code	Quantity
20	L5		Quality	3.0

The quantity scrapped is deducted from the WIP QOH balance for the current operation’s reject queue. It is added to the cumulative scrapped quantity.

WIP Lot Input Queue Scrap Data

Use the WIP Lot Input Queue Scrap Data frame to record the WLT-controlled material being scrapped from an operation’s input queue. It displays in Backflush Transaction (18.22.13).

**Fig. 10.13**  
WIP Lot Input Queue Scrap Data

Row	Lot/Serial	Ref	Code	Quantity
	L1		Quality	2.0

Work Center: 12000      Machine:      General # 2  
 Department: 10      General  
 To Queue: EA      Conversion: 1.0000  
 In Queue: 2.0      From Queue:      Multi Entry:   
 Out Queue: 2.0      Reason Code:      Multi Entry:   
 Reject Queue: 2.0      Reason Code:      Multi Entry:

Lot/Serial	Ref	Code	Quantity
L1		Quality	2.0

The quantity scrapped is deducted from the WIP QOH balance for the current operation’s input queue. It is added to the cumulative scrapped quantity.

WIP Lot Output Queue Scrap Data

Use the WIP Lot Output Queue Scrap Data frame to record the WLT-controlled material being scrapped from an operation’s output queue. It displays in Scrap Transaction (18.22.18).

**Fig. 10.14**  
WIP Lot Output Queue Scrap Data

WIP Lot Output Queue Scrap Data - Qty Scrapped: 2 EA				ID: 100
Row	Lot/Serial	Ref	Code	Quantity
	L1		Quality	2.0
Work Center: 12000		Machine:		General # 2
Department: 10		General		
To Queue: EA		Conversion: 1.0000		
In Queue: 2.0		From Queue:		Multi Entry: <input type="checkbox"/>
Out Queue: 2.0		Reason Code:		Multi Entry: <input type="checkbox"/>
Reject Queue: 2.0		Reason Code:		Multi Entry: <input type="checkbox"/>
Lot/Serial	Ref	Code	Quantity	
L1		Quality	2.0	

### Recording Labor Data

Use the Labor WIP Lots frame to associate run and setup labor time with corresponding lot/serials. This frame appears in the following programs when the output queue of the operation being processed is WLT controlled:

- Repetitive Setup Transaction (18.13)
- Run Labor Transaction (18.22.14)
- Setup Labor Transaction (18.22.15)

**Fig. 10.15**  
Labor WIP Lots

Labor WIP Lots	
Lot/Serial:	<input type="text"/>
Lot/Serial:	<input type="text"/>
Lot/Serial:	<input type="text"/>
Lot/Serial:	<input type="text"/>
Lot/Serial:	<input type="text"/>
Lot/Serial:	<input type="text"/>
Lot/Serial:	<input type="text"/>
Lot/Serial:	<input type="text"/>
Lot/Serial:	<input type="text"/>
Lot/Serial:	<input type="text"/>

Labor time reporting is not required. Any labor WIP lot/serial numbers entered are not validated. This frame links the labor and employee to the specified WIP lot/serial numbers. Labor time is reported as produced material by WLT reports.

### Recording Rework Data

Use the WIP Lot Rework Data frame to specify the WIP lot/serial to rework. Optionally, use this frame to assign new WIP lot/serials to that WIP material.

The WIP Lot Rework Data frame appears in the Repetitive Rework Transaction (18.16) and Rework Transaction (18.22.17) when the reject-from queue is WLT controlled. This frame appears immediately after the Destination Work Center and Machine frame.

**Fig. 10.16**  
WIP Lot Rework Data

WIP Lot Rework Data - Qty to Rework: 4 EA

Produced By Op: 20

Lot/Serial:

Reference:

Reworked Lot/Serial:

Items reworked can come from a previous operation's reject queue. Use the lookup on the Lot/Serial field to select the correct value.

Before moving the reworked WIP lot/serial to the destination locations, the system checks the following settings in WIP Lot Trace Control or in the corresponding WLT routing and BOM registrations:

- Split WIP Lots
- Combine WIP Lots
- Max Lot Size

When you move reworked WIP lot/serial quantities to the last operation in a routing, you must enter material receipt information for the reworked WIP lot/serial. Receipt information is entered using the Receipt Data Input data frame. Values for Qty, UM, and Lot/Serial default from the values you previously entered in the transaction; Multi Entry is not editable. Lot/Serial and Ref default from the values you entered in the WIP Lot Rework Data frame.

#### QOH and Queue Balances

The information you enter in the WLT frames is used to adjust QOH balances and cumulative accounts for the input and output queues of the affected operations. The reject queue from where material was moved is reduced by the quantity reworked. The quantity reworked is added to the cumulative reworked, consumed, and produced quantities for the WIP lot/serial. When you receive reworked material into finished material inventory, that quantity is reduced from the QOH of the output queue of the last operation.

#### WIP Lot Move Data

Use the WIP Lot Move Data frame to record the WIP lot/serials, references, and quantities of material being moved. This frame does not appear if you are moving WIP quantities to finished goods inventory. Instead, the Receipt Data Input frame appears for receipt of finished goods into inventory.

You can use a WIP lot/serial number as the finished item lot/serial number. If you are using lot groups (a feature of the Regulatory Attributes module) to create automatic lot numbers, that function creates and assigns the lot/serial number for this finished item. The lot/serial assigned to the finished item is saved to WLT tracing history.

**Fig. 10.17**  
WIP Lot Move Data Frame

WIP Lot Move Data - Qty To Move: 20 EA			ID: 100
Lot/Serial	Ref	Quantity	
L100		20.0	
Work Center: 12000		Machine:	General # 2
Department: 10		General	
Unit of Measure: EA		Conversion: 1.0000	
Lot/Serial	Ref	Quantity	
L100		<input type="text" value="20.0"/>	

The WIP Lot Move Data frame follows the Work Center and Machine frame in Move Transaction (18.22.19). Use the frame to specify quantities to move from the output queue of the indicated operation to the input queue of the next operation.

This frame appears in Sub Shipper Maintenance (18.22.5.5) and Sub Container Maintenance (18.22.5.4) when moving WLT-controlled WIP material to a subcontract operation. The lot/serial quantities you enter are moved to the subcontract location when you confirm the shipper using Sub Shipper Issue (18.22.5.11).

This frame also appears in Operation Move Transaction (16.20.6) immediately after the Source/Destination Work Center and Machine frame. The WIP lot/serials you specify in the WIP Lot Move Data frame are moved from the source location to the destination location you specify in the Source/Destination Work Center and Machine frame.

### Current Work Center and Machine

Use this frame to specify the work center and machine location from which input WIP lot/serials will be consumed by the operation. For example, using Work Order Component Issue (16.10), this frame appears after you indicate the work order number, ID, and operation from where the components or WIP material will be issued.

The Current Work Center and Machine frame appears in Work Order Receipt (16.11) and Work Order Component Issue (16.10) when the operation being processed is WLT controlled.

**Fig. 10.18**  
Current Work Center and Machine Frame

Current Work Center and Machine	
Work Center:	<input type="text" value="100-01"/>
Machine:	<input type="text"/>

### Using WLT with Work Orders

When using WIP Lot Trace (WLT) in a Work Orders manufacturing environment, you should be aware of the following points:

- Work Order Receipt Backflush (16.12) is disabled because it does not let you report production on an operation-per-operation basis.
- You must specify an operation when processing a receipt, issue, or labor transaction for a WLT-controlled work order.

The following sections describe the programs in the Work Orders module affected by WLT changes.

## Processing a Work Order

The workflow in Figure 10.19 shows two alternative methods of processing a work order. The process consists of three steps:

- Issue components to the work order.
- Report labor performed.
- Receive finished goods.

WLT frames are used to collect information at each of these steps when you process a WLT-controlled work order. A work order is WLT controlled when:

- Trace Parents is Yes in WIP Lot Trace Control, or
- A WLT BOM registration is active for the parent item being manufactured and Trace Parents is Yes for that registration.

**Fig. 10.19**  
Work Orders Workflow

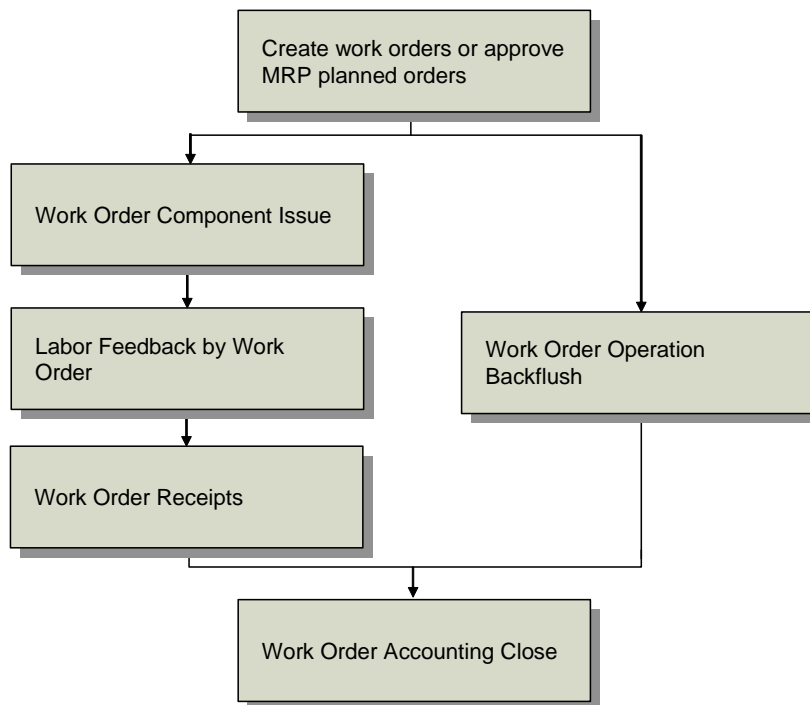

Assume that you trace WIP material through all work order operations. First, issue components to the first operation using Work Order Component Issue (16.10).

Use these three WLT frames to collect WIP lot/serial tracing information:

- Issued to WIP Lots. See page 215.
- Current Work Center and Machine. See page 213.
- WIP Lot Input Queue Issue Data. See page 207.

**Note** Issued to WIP Lots is the only frame used when issuing components to the first operation of a routing.

After components are issued and the operation is complete, use Labor Feedback by Work Order (16.20.1) to report labor for the operation. Use the Destination Work Center and Machine and WIP Lot Output Queue Receipt Data frames to collect WIP lot/serial tracing information.

Issue components and report labor for the remaining operations. After all operations are complete, receive the finished goods into inventory using Work Order Receipts (16.11). Use the Current Work Center and Machine frame to indicate where the WIP lots or serials being received currently reside.

See page 206 and page 208.

You can use Work Order Operation Backflush (16.19) as an alternative to following separate steps. It incorporates the functions of the three programs previously described. The WLT frames that display in the three separate programs also appear in Work Order Operation Backflush.

### Issuing Component and WIP Material

Use Work Order Component Issue (16.10) to issue component and WIP material to WLT-controlled work orders. This program performs the following WLT functions:

- Prompt for WIP lot/serials to issue.
- Prompt for WIP lot/serials to be produced from the issued lot/serials.
- Consume WIP lot/serials from WIP lot inventory balances.
- Update and record WIP lot/serial QOH balances for all affected operation queues.

This program issues the WIP and component material you specify to the WIP lots you also specify. It updates WIP QOH balances and generates tracing records for components, WIP material issued, and WIP material produced. Location and tracing information is entered in three WLT frames:

- Current Work Center and Machine. See page 213.
- WIP Lot Input Queue Issue Data. See page 207.
- Issued to WIP Lots

The Issued to WIP Lots frame appears when the operation's output queue is WLT controlled. This WLT frame appears only in Work Order Component Issue. Use it to specify the produced WIP lot/serials to which the specified components and WIP material are being issued. The WIP material to be issued is specified in the WIP Lot Input Queue Issue Data frame that appears immediately before this frame.

**Fig. 10.20**  
Issued To WIP Lots Frame

The screenshot shows a window titled "Issued To WIP Lots". Inside the window, there is a vertical list of ten input fields, each labeled "Lot/Serial:" followed by a text box. The first text box is currently empty, while the others are also empty.

## Reporting Labor

The three Shop Floor Control labor feedback programs use the WLT Destination Work Center and Machine and WIP Lot Output Queue Receipt Data frames to capture tracing information for the labor being reported:

- Labor Feedback By Work Order (16.20.1)
- Labor Feedback By Employee (16.20.2)
- Labor Feedback By Work Center (16.20.3)

See Chapter 7, “Shop Floor Control,” on page 103.

These labor feedback programs perform the following WLT functions:

- Prompt for WIP lot/serial produced.
- Update and record WIP lot/serial QOH balances for affected queues.
- Record labor feedback and lot/serial tracing information.

See page 206 and page 208.

## Receiving Finished Goods

Use Work Order Receipt (16.11) to receive finished goods manufactured with WLT-controlled routings. Use the detail fields to specify the lot/serial, reference, and other details of the WIP material being received. This program consumes the WIP lot/serials being received into finished goods inventory. Then it updates WLT tracing history, WIP QOH balances, and receipt and issue information.

Use the Current Work Center and Machine frame to specify the work center and machine from where the WIP lot/serial inventory should be consumed. The WIP Lot Output Queue Issue Data frame is used to enter a list of the WIP lot/serials that should be consumed from the previous operation’s output queue in the specified work center and machine. The WIP Lot Output Queue Issue Data frame appears only in Work Order Receipt.

**Fig. 10.21**  
WIP Lot Output Queue Issue Data Frame

The system calculates and records WIP QOH balances for standard work orders in three steps:

- Each finished material lot/serial quantity moved into inventory is deducted from the corresponding QOH balance for the WIP lot/serial specified in the WIP Lot Output Queue Issue Data frame.
- The system checks QOH balances against settings in WIP Lot Trace Control.
- QOH balances are recorded to tracing history.

## Work Order Operation Backflush

Work Order Operation Backflush (16.19) combines:

- The issuing functions of Work Order Component Issue (16.10)
- The labor reporting functions of Labor Feedback by Work Order (16.20.1)
- The receipt functions of Work Order Receipts (16.11)

See Chapter 6, “Work Orders,” on page 73.

Three WLT frames are used to collect WIP tracing information:

- WIP Lot Input Queue Issue Data. See page 207.
- Destination Work Center and Machine. See page 206.
- WIP Lot Output Queue Receipt Data. See page 208.

## Managing Scrap

Scrap refers to unusable materials. In the manufacturing process, there can be two kinds of scrap:

- Component materials issued to the work order that are unusable, known as *component item scrap*
- Item materials built by the work order that are unusable, known as *finished item scrap*

When additional component material is required for a work order because item material was lost or unusable, the replacement component materials should be issued to the work order with Work Order Component Issue (16.10). This correctly results in an unfavorable material usage variance for the order.

### Reporting Scrap in Work Orders

Record finished material scrap using Work Order Receipt (16.11). Use Operation Scrap Transaction (16.20.7) to remove scrap WIP material from a work order operation. Use the WIP Lot Input Queue Scrap Data and WIP Lot Output Queue Scrap Data frame to record scrap lot/serials for material at WLT-controlled work order operations.

See page 210.

The program generates WO-SCRAP operation history records for transactions. It reduces QOH balances for the operation input and output queues for the lot/serial quantities specified in the WLT frames. The scrapped quantities are also added to the cumulative scrapped quantities for the lot/serials. The cumulative scrapped quantity for each queue is also increased by the lot/serial quantity scrapped.

You can report reject materials at the operation level using Shop Floor Control. However, only units recorded as scrap during work order receipt affect the general ledger (GL), debiting Scrap and crediting WIP. Rejects recorded in Shop Floor Control are for reporting only, and have no GL effect.

### Processing a Subcontract WO Operation

Processing a subcontract work order operation when using WLT adds a few minor steps to the normal procedure.

- 1 Create a subcontract purchase order for the work order operation using Purchase Order Maintenance (5.7).
  - a Set Type to S for subcontract.
  - b Use the work order subcontract information frame to optionally specify the work order, ID, and operation where the subcontract services are required.
  - c Optionally specify the WIP lot/serial of that material. This lot/serial prints on reports generated by Purchase Order Print (5.10).

See “Purchase Order Maintenance” on page 220 for details.
- 2 Use Work Order Component Issue (16.10) to issue the components for the operation. For example, many manufacturers send component item kits and WIP to their subcontractors or subcontract assemblers. In these situations, you issue the components and WIP.
  - a Use the WLT Current Work Center and Machine frame to specify the subcontract work center and machine to which components will be issued for this subcontract operation.
  - b Use the WIP Lot Input Queue Issue Data frame to specify the lot/serials sent to the subcontractor.
  - c Use the Issued to WIP Lots frame to specify the lot/serials processed and returned by the subcontractor.
- 3 Report completed subcontract labor using Labor Feedback by Work Order (16.20.1).
  - a Operation Complete should be No.
  - b Move Next Op should be Yes.
  - c Use the WIP Lot Output Queue Data frame to specify the WIP lot/serials produced. Lot/serials default from the lot/serials entered in the Issued To WIP Lots Data frame.
- 4 Register the subcontract processing performed when you receive the subcontract material using Purchase Order Receipt (5.13.1). The work order operation is automatically closed. See “Receiving Subcontract POs” on page 221 for details.

### Processing Subcontract Operations for Multiple Subcontractors

Follow the procedure for a single subcontractor with the following additional steps:

- Create a separate subcontract purchase order for each subcontractor being used at the work order operation.
- When you issue the components and WIP for the subcontract operation, use the WLT Current Work Center and Machine frame to specify the specific subcontractor that will process the operation.

See “Processing a Subcontract WO Operation” on page 218.

Use the WIP Lot Inventory Status Report (3.22.13.13) to see where specific WIP and item component material reside during manufacturing.

## Using WLT with Advanced Repetitive

The following sections describe the Advanced Repetitive programs affected by WLT changes.

### Backflushing WIP Material

Use Backflush Transaction (18.22.13) to report production activity. This program uses five frames to collect WLT information. WLT frames appear and are used only when backflushing operations for WLT-controlled routings.

Use the WLT frames to record WIP material lot/serial information for the current operation's input, output, scrap, and reject queues. Use the Destination Work Center and Machine frame to specify where the produced WIP material will be moved. This frame appears only when Move to Next Op is Yes. WLT frames added to Backflush Transaction appear in this order when the corresponding queue is WLT controlled:

- WIP Lot Input Queue Issue Data. See page 207.
- Destination Work Center and Machine. See page 206.
- WIP Lot Output Queue Receipt Data. See page 208.
- WIP Lot Reject Data. See page 209.
- WIP Lot Scrap Data. See page 209.

### Reporting Run and Setup Labor

WLT adds the Labor WIP Lots frame to Run Labor Transaction (18.22.14) and Setup Labor Transaction (18.22.15). Any run or setup labor you report for WLT-controlled operations is associated with the WIP lot/serials you indicate in this frame.

See page 211.

Use WIP Lot Convert Trans Report (3.22.13.15) or Operation Trans Detail Inquiry (18.22.4.2) to review the labor associated with any WIP lot/serial.

### Reworking Rejected Material

Use Rework Transaction (18.22.17) to move previously rejected WLT-controlled material back into production. Use the WIP Lot Rework Data frame to indicate which lot/serials were reworked. The reworked WIP material is moved to the location you indicate in To Operation and To Queue in the work center and packing list you specify in the Destination Work Center and Machine frame.

### Scrapping Reject Material

Use Scrap Transaction (18.22.18) to scrap or remove WIP quantities from any queue of an operation without backflushing. If you scrap quantities from a WLT-controlled queue, use the WLT frames to specify the lot/serials of the WIP material you are scrapping. Depending on which queue you are scrapping material from, these WLT frames can appear:

- WIP Lot Input Queue Scrap Data. See page 210.
- WIP Lot Output Queue Scrap Data. See page 211.
- WIP Lot Reject Queue Scrap Data. See page 210.

See page 206 and page 212.

The WIP QOH at each queue is reduced by the quantity scrapped at the indicated work center and machine. Additionally, the quantity scrapped is added to the cumulative scrapped quantity for the indicated lot/serials.

### Adjusting WIP Quantities for WLT-Controlled Queues

Use WIP Adjust Transaction (18.22.21) to adjust quantities at an operation's input, output, or reject queues. The current queue balances display when you run the program.

When adjusting quantities for WLT-controlled operations, Reason Code and the three queue quantity fields are not editable. Use the WLT frames to specify adjustments to QOH balances for the WIP lot/serials in each queue. You can create entries for new lot/serials and optionally enter reason codes as needed. One WLT frame is used for each queue.

The three WLT frames appear in this order:

- WIP Lot Input Queue Adjust Data
- WIP Lot Output Queue Adjust Data
- WIP Lot Reject Queue Adjust Data

### Using WLT with Purchasing

Various purchasing programs used to support subcontracting let you trace subcontract WIP material only when using the Advanced Repetitive module. The following points should be noted:

- You can enter the lot/serial of subcontract material when creating the PO. This lot/serial prints on the report produced by Purchase Order Print (5.10).
- PO Shipper Maintenance (5.13.14), PO Container Maintenance (5.13.13), and PO Shipper Receipt (5.13.20) cannot process any subcontract PO line item that references a WLT-controlled operation.

### Purchase Order Maintenance

Part of the subcontracting process is to use Purchase Order Maintenance (5.7) to create a subcontract PO for the subcontract operation. When creating a subcontract PO for line items that reference Advanced Repetitive cumulative orders, use the lot/serial field to enter the WIP lot/serial number of the material being sent for subcontract processing; see Figure 10.22.

When the system generates the cumulative order ID, it searches for purchase orders associated with the cumulative order and automatically updates the work order ID and operation on the purchase order. The system also replaces existing closed cumulative order IDs with an open cumulative order ID on the appropriate purchase orders. The purchase orders must be connected to a subcontract routing operation through Subcontract Routing/OP PO Maint (5.11) or Subcontract Order MRP % Maint (5.5.1.21).

**Fig. 10.22**  
Purchase Order Maintenance WLT Lot/Serial Field

The screenshot shows a software interface with the following fields:
 

- Work Order: ID: [ ]
- Operation: 0
- Subcontract Type: [ ]
- Lot/Serial: [ ]

 A callout box with the text "Indicate the WIP lot/serial here." has a line pointing to the "Lot/Serial:" field.

The lot/serial entered in this field defaults as the input lot/serial number in the WIP Lot Input Queue Issue Data frame in Purchase Order Receipts when the order is being received. This value also prints on reports generated by Purchase Order Print (5.10).

### Receiving Subcontract POs

Purchase Order Receipts (5.13.1) captures line item receipt data for subcontract-type lines that reference Advanced Repetitive cumulative order operations that are WLT controlled.

This program cannot be used to backflush lot/serial controlled components, or components that cannot be issued from the default issue location. Use Backflush Transaction (18.22.13) to manually backflush the operation for the component material received. If you attempt to receive this type of component material, only the extended subcontract cost for the PO is added to the cumulative order operation's cumulative subcontract cost.

Use the WIP Lot Input Queue Issue Data frame to enter details of the WIP material being consumed from the input queue of the subcontract operation. Use the WIP Lot Output Queue Receipt Data frames to record details of the material being produced and moved to the output queue of this subcontract operation.

The system backflushes these WIP lot/serial numbers. The input WIP lot/serials are consumed, and the output WIP lot/serials are produced. WIP lot/serial QOH balances, cumulative totals, and tracing history records are updated accordingly. The supplier ID is used as the work center ID to update WIP lot/serial QOH balances.

When WIP Lot Trace (WLT) is active, all of the inventory-related fields in the purchase order receipt detail are disabled, including Site, Location, Lot/Serial, Ref, Supplier Lot, Multi Entry, and Change Attributes. All lot/serial information should be specified using the WLT frames that display.

**Note** If Move to Next Op is Yes, then the WIP lot/serials specified in the WIP Lot Output Queue Receipt Data frame are moved to the input queue of the next milestone operation.

### Returning Purchased Materials

Purchase Order Returns (5.13.7) updates QOH balances, cumulative totals, and WLT tracing history to reflect the return of materials at a subcontract operation. The WIP Lot Input Queue Issue Data and WIP Lot Output Queue Receipt Data frames appear when processing WLT-controlled material. Any material being returned is reverse backflushed.

For example, instead of receiving material to WIP, material is removed from WIP. The system basically processes a PO receipt with all negative quantities.

If Move To Next Operation is Yes, the system removes WIP lot/serials from WIP inventory at the input queue of the first milestone operation following the subcontract operation. When this value is No or a milestone operation does not exist after the subcontract operation, then the system removes the WIP lot/serials from the output queue of the subcontract operation.

### Processing a Subcontract Operation

Processing a subcontract operation when using WIP Lot Trace and Advanced Repetitive adds a few minor steps to the subcontract procedure.

**Note** This procedure assumes that you have already backflushed all operations previous to the subcontract operation.

- 1 Create a scheduled order in Supplier Scheduled Order Maintenance (5.5.1.13). Specify the appropriate cumulative work order ID and subcontract operation.
 

**Note** The system automatically populates the work order ID and operation fields when it creates a cumulative ID through any Advanced Repetitive transaction.
- 2 Create a subcontract shipper in Sub Shipper Maintenance (18.22.5.5).
  - a Use the parent item site as the ship-from and the supplier as the ship-to.
  - b Use the cumulative order ID and subcontract operation used on the scheduled order.
  - c Specify the WIP lot/serials and quantity being sent to the subcontractor in the WLT WIP Lot Move Data frame. Select Help to display a list of WIP lot/serials produced at the previous operation.

See page 212.

- 3 Print the subcontract shipper using Sub Shipper Print (18.22.5.9). The WIP lot/serials entered in the WIP Lot Move Data frame display as Lots Shipped.
- 4 Confirm the subcontract shipper using Sub Shipper Issue (18.22.5.11). This moves the indicated WIP lot/serials from the output queue of the previous operation to the input queue of the indicated operation.

- 5 Receive the scheduled order in Purchase Order Receipts (5.13.1), PO Shipper Maintenance (5.13.14), or PO Shipper Receipts (5.13.20).
  - a Use the WIP Lot Input Queue Issue Data frame to specify the WIP lot/serials that were sent to the subcontractor. Select Help to display a list of WIP lot/serials as they appeared on the subcontract shipper. See page 207.
  - b Use the WIP Lot Output Queue Receipt Data frame to specify the WIP lot/serials being received from the subcontractor. The lot/serial you entered in the input queue frame defaults to the output queue frame. See page 208.

### Processing a Subcontract Operation for Multiple Subcontractors

Follow the procedure outline above, with the following additional steps:

- Create a separate subcontract scheduled order for each subcontractor being used at the work order operation.
- Create, confirm, and print separate subcontract shippers for each subcontractor.
- When you backflush the next operation, the subcontract WIP lot/serials you received in the Purchase Order Receipts Output Queue Receipt Data frame appear on the WIP Lot Input Queue Issue Data frame browse.

Use the WIP Lot Inventory Status Report (3.22.13.13) to display the operation and queue where specific WIP and item material is located during manufacturing.

### Using WLT with Repetitive

The following sections describe the Repetitive programs affected by WLT changes.

#### WLT in Repetitive and Advanced Repetitive

WLT makes many of the same changes to Repetitive and Advanced Repetitive programs.

- The changes made to Rework Transaction (18.22.17) are also made to Repetitive Rework Transaction (18.16).
- Likewise, Repetitive Setup Transaction (18.13) is modified in the same way as the Advanced Repetitive module's Setup Labor Transaction (18.22.15).

See page 219.

When you use these programs to process any WLT-controlled material, the same WLT frames appear.

#### Reporting Labor

Repetitive Labor Transaction (18.14) uses the same WLT frames as Backflush Transaction (18.22.13). WLT frames appear and are used only when processing WLT-controlled material.

See page 219.

The WLT frames are used to enter input, output, and reject WIP lot/serials and quantities. This information is used to record the appropriate tracing records and update WIP lot/serial QOH balances.

Use the WLT frames to enter WIP material lot/serial information for the current operation's input, output, and reject queues. Use the Destination Work Center and Machine frame to specify where the backflushed material will be moved. This frame appears only when Move to Next Op is Yes.

WLT frames added to this program appear in this order when the corresponding queue is WLT controlled:

- WIP Lot Input Queue Issue Data. See page 207.
- Destination Work Center and Machine. See page 206.
- WIP Lot Output Queue Receipt Data. See page 208.
- WIP Lot Reject Data. See page 209.

### Handling Reject Material

The Repetitive Reject Transaction (18.17) displays the WIP Lot Input Queue Issue Data and WIP Lot Reject Data frames. Use these frames to enter the input lot/serials to issue and reject WIP lot/serials to produce. The information entered in these frames updates tracing history records and WIP lot/serial QOH balances.

See page 207 and page 209.

### Tracing Scrap Material

When scrapping WLT-controlled material, the Repetitive Scrap Transaction (18.18) displays the WIP Lot Reject Queue Scrap Data frame. Use it to enter the WIP lot/serial and quantity of the material being scrapped. The information you enter updates tracing history records and WIP lot/serial QOH balances.

See page 210.

### Reporting Repetitive Transaction History

The Repetitive Trans Detail Inquiry (18.4.2) and Repetitive Trans Detail Report (18.4.26—an enhanced report available only in .NET UI) are modified to display WIP lot/serial information connected with an operation history record. Any tracing records associated with the operation history record are displayed. Additionally, any WIP lot/serials recorded by a scrap, reject, rework, or adjust transaction are also displayed.

## Reporting WIP Lot Trace Data

The WIP Lot Trace module provides 10 reports and inquiries for reviewing WLT data. These reports and inquiries are designed to clearly show consumption and production data at the operation and WIP lot/serial level.

Some existing reports and inquiries also display WLT data.

When using WLT, you should use the WLT reports to report any WLT-controlled WIP and item component material. WLT does not trace WIP at non-milestone operations even if those operations belong to a WLT-controlled routing.

If you use Advanced Repetitive reports to view QOH balances for WLT-controlled routings or BOMs, the report may show that there is WIP material in the input queue of non-milestone operations. If you report for the same routing or BOM using WLT reports, these reports will show that the WIP lot/serial QOHs are in the input queue of the following milestone operation.

Table 10.12 summarizes WIP Lot Trace reports.

**Table 10.12**  
WIP Lot Trace Reports

Report	Menu Number	Description
WIP Lot Inventory Status Report	3.22.13.13	Displays the WIP lot inventory associated with each discrete work order, or repetitive cumulative work order.
Item Lot Ship Transaction Report	3.22.13.14	Shows ISS-SO transaction history (tr_hist) records created by Sales Order Shipments (7.9.15) or Pre-Shipper/Shipper Confirm (7.9.5) for a selected finished material lot. Lets you easily identify the customer or ship-to where the finished material lot was shipped.
WIP Lot Convert Transaction Report	3.22.13.15	Shows operation history (op_hist) data and tracing information for transactions where material conversion occurred. This refers to, for example, any operation where a component is introduced and becomes part of the WIP material, or where a rejected WIP material was reworked and assigned to a different lot/serial. The report shows the data recorded in these programs: <ul style="list-style-type: none"> <li>• Purchase Order Receipts (5.13.1)</li> <li>• Purchase Order Returns (5.13.7)</li> <li>• Work Order Component Issue (16.10)</li> <li>• Work Order Receipt (16.11)</li> <li>• Work Order Operation Backflush (16.19)</li> <li>• Labor Feedback by Work Order (16.20.1)</li> <li>• Labor Feedback by Employee (16.20.2)</li> <li>• Labor Feedback by Work Center (16.20.3)</li> <li>• Repetitive Setup Transaction (18.13)</li> <li>• Repetitive Labor Transaction (18.14)</li> <li>• Repetitive Rework Transaction (18.16)</li> <li>• Repetitive Reject Transaction (18.17)</li> <li>• Backflush Transaction (18.22.13)</li> <li>• Run Labor Transaction (18.22.14)</li> <li>• Setup Labor Transaction (18.22.15)</li> <li>• Rework Transaction (18.22.17)</li> </ul>

Report	Menu Number	Description
WIP Lot Non-Convert Trans Report	3.22.13.16	Shows operation history data that references WIP lot and serial numbers, but does not include records where material was converted. WIP lot and serial numbers recorded during transactions in the following programs are reported: <ul style="list-style-type: none"> <li>• Repetitive Reject Transaction (18.17)</li> <li>• Reject Transaction (18.22.16)</li> <li>• Repetitive Rework Transaction (18.16)</li> <li>• Rework Transaction (18.22.17)</li> <li>• Repetitive Scrap Transaction (18.18)</li> <li>• Scrap Transaction (18.22.18)</li> <li>• WIP Adjust Transaction (18.22.21)</li> </ul> <b>Note:</b> Information recorded in the rework transaction is reported only if the WIP lot or serial numbers remained the same for the reworked material.
WIP Lot Inquiry	3.22.13.17	Displays WIP lot cumulative quantities by lot or work order ID at each operation. The cumulative totals displayed at each operation are for cumulative quantity produced, consumed, scrapped, adjusted, rejected, reworked, transferred in, and transferred out. An enhanced browse version is available at menu 22 for .NET UI.
Supplier Lot Transaction Report	3.22.13.18	Displays PO Receipt transactions for the selected item, where a supplier's lot number was entered into the Supplier Lot number field. Use the report to identify the supplier lot associated with an internally assigned lot.
WIP Lot Where-Used Report	3.22.13.19	Generates a where-used report for selected component or WIP material lots, showing where WIP material or component lots were consumed, and what material lots were produced from them.
WIP Lot Actual Bill Report	3.22.13.20	Displays which material was used to make a WLT-tracked finished or WIP lot. The report shows issue and receipt transactions related to the WIP or parent material.
WIP Lot Browse	3.22.13.22	Enhanced version of WIP Lot Inquiry for .NET UI users.

# Quality Management

Quality Management supports testing of incoming material, finished products, and inventory; inspection of first articles, processes, and items in-process; and destructive testing.

***Introduction* 228**

Describes features and testing methods of the Quality Management module.

***Setting Up Quality Management* 228**

Outlines the specification requirements, control programs, procedures, and sampling patterns that must be defined before running the module.

***Executing Stand-Alone Tests* 233**

Defines quality orders and explains how to use them to run stand-alone tests.

***Conducting Process Inspections* 235**

Outlines the requirements and environments of a process inspection.

***Conducting Other Tests* 237**

Describes which other tests can be performed with quality orders, including audits, inspections, validation, and destructive testing.

***Printing Test Results* 238**

Shows how to print test results with Certificate of Analysis Print and what the certificate can be used for.

## Introduction

The Quality Management module (19) enables you to test incoming material, finished products, and inventory; inspect first articles, processes, or items in-process; and perform destructive testing. For all but in-process inspection, you manage quality with quality orders: documents that specify what is tested, how, and when. You can define specifications, test procedures, and inventory sampling, and record the results of testing.

**Fig. 11.1**  
Inspection Methods

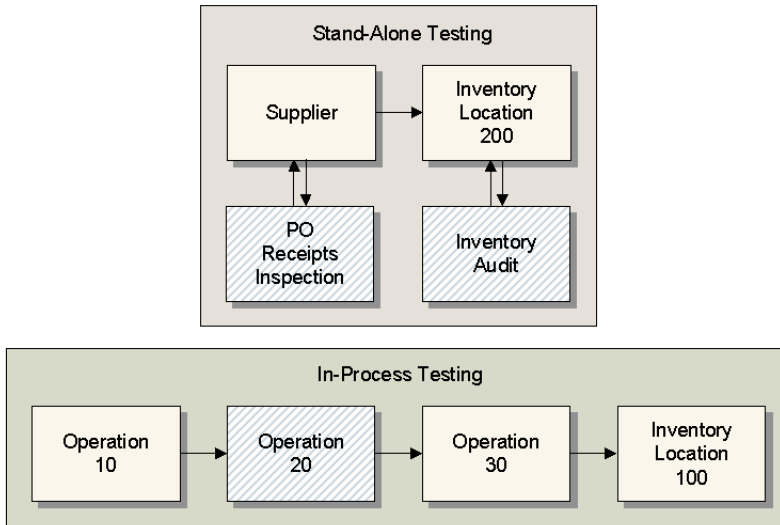

Testing is generally done in one of two ways:

- As a stand-alone task—at purchase receipt or at an inspection station. For this method, you create a quality order to control quantities and dates. The order provides authority to move inventory, perform work, and route items to various locations after the work is completed.
- As an operation within a work order or repetitive schedule routing. In this case, material is moved to a location where the quality tests are performed. Reporting occurs in the Shop Floor Control or Repetitive modules. For work orders without shop floor control reporting, use Test Results Maintenance (19.13) to record results.

Material that is spoiled, damaged, or made obsolete by an engineering change can be quarantined by changing its inventory status code in Inventory Detail Maintenance (3.1.1) to restrict inventory transactions.

## Setting Up Quality Management

Before using Quality Management, set up appropriate control program values. Before you can report quality test results, you must define a quality document, called a *specification*. Test specifications control the testing process, describing each test step, the characteristic to be measured, the measurement tolerance, and the sequence for conducting tests.

If you have tests that apply to more than one item, you can define master specifications. These serve as templates for defining specifications for individual items.

If multiple steps are required for a stand-alone quality test, define them as a procedure in Procedure Maintenance (19.2.1).

You may also want to establish a sampling pattern. These define how items will be selected for testing if all items are not to be tested. The two options are lot intervals and number of days before expiration.

## Setting Up Control Programs

Enter appropriate values in Quality Management Control (19.24). Most of the settings affect quality orders.

**Fig. 11.2**  
Quality Management Control (19.24)

The screenshot shows the 'Quality Management Control' window with the following settings:

- Auto Order Numbers:
- Next Order Number: 1004
- Next Batch: 6
- Quality Order Comments:
- Inspection Site: 30000
- Inspection Location: inspect
- Procedure Comments:

If you want quality orders to be numbered automatically, set Auto Order Numbers to Yes. The system then uses the Next Order Number and Next Batch when new orders are created.

Specify the default inspection site and location for new quality orders. Items being inspected are transferred from their current site and location to the inspection site and location specified on the order.

## Defining Specifications

When a set of tests apply to more than one item, set up the specification in Master Specification Maintenance (19.1.1). A master specification is a list of index numbers, characteristics, specifications, and units of measure, and additional information entered as transaction comments.

You can include tolerances, or acceptable deviations from standard value. These specifications are used by quality orders and in-process inspection operations.

**Fig. 11.3**  
Master Specification Maintenance (19.1.1)

The screenshot shows the 'Master Specification Maintenance' window with the following details:

- Document: PROC-111
- Expiration Date: 02/28/2007
- Description: Standard Test Procedure

Number	Characteristic	Specification	Measure
1	Purity	>99.9	%
2	Enter your name	*	Actual Value

The index numbers associated with characteristics and specifications must be unique but need not correspond to an actual test or inspection sequence.

## Specification Values

A specification can take any of the following forms:

- A character string. This is a list of elements separated by semicolons. For example, if acceptable colors for an item are gray and black, the specification is gray;black.
- A numeric value with a tolerance. This is stated as a range, with minimum and maximum values separated by the pipe (|) character (Shift+\). For example, if the idle speed of an engine is 1000 +/- 150 rpm, the specification is 850 | 1150.

You can also designate a range within a range. In the previous example, a range of +/- 50 rpm, together with a tolerance of +/- 150, is designated by the string 850 | 950 | 1050 | 1150. The system looks only at minimum and maximum values, but this format allows you to see the optimal range within a tolerance.

- A comparative symbol (<, >, <=, or >=) and a numeric value. This type of specification provides a value against which a measurement is seen as less than, more than, less than or equal to, or more than or equal to. For example, if the acceptable weight for an item is less than 25 grams, the specification is entered as <25.
- An asterisk (\*), indicating a wildcard value. This allows any value to be recorded and accepted, a useful feature for collecting data for failure analysis.

**Note** You can record the name of a tester by calling the first test Name and defining its specification as the wildcard. The first required test result is then the tester's name.

## Defining Item Specifications

Use Item Specification Maintenance (19.1.13) to attach a set of specifications to a routing or quality control operation. You can use a master specification as a template. You can change and add to the information that comes from a master specification.

An item specification can list several characteristics and specifications, but only for a single item and a single operation. Also, a quality control operation is linked to only one item specification. Each specification can include any number of steps, indicated by the Number field.

If several item specifications are required to inspect an item, they must be spread out over several operations, one operation for each specification.

**Fig. 11.4**  
Item Specification Maintenance (19.1.13)

The screenshot shows a window titled "Item Specification Maintenance" with a menu bar containing "Go To" and "Actions". The main content area is divided into several sections:

- Item Information:** Item Number: WLT18-P1, WIP Lot Std Rep
- Routing/Procedure:** Routing/Procedure: WLT18-P1, Operation: 10
- Document:** Document: PROC-111, Standard Test Procedure
- Number and Start Effective:** Number: 1, Start Effective: (blank)
- Specification Fields:**
  - Characteristic:
  - Attribute:
  - Test Method:
  - Specification:
  - Measure:
  - Start Effective:
  - End Effective:
  - Comments:

If an item does not have a routing or procedure, you can still link it to a specification by leaving Routing/Procedure blank and Operation as zero (the default).

Use specifications to record information about sample size. For instance, you can set up an item specification with three test steps:

- One for sample size
- One for quantity accepted
- One for quantity rejected

Item specifications can be maintained in the Product Change Control module. The effective date is used to phase in changes managed with product change orders.

See *User Guide: QAD Master Data* for information about the PCC module.

## Setting Up Procedures

A quality procedure consists of one or more operations—generally, inspection or testing operations—linked to a work center. Define quality procedures in Procedure Maintenance (19.2.1). Quality procedures are used by quality orders in the same way routings are used by work orders.

See “Executing Stand-Alone Tests” on page 233.

**Fig. 11.5**  
Procedure Maintenance (19.2.1)

The screenshot shows a window titled "Quality Order Maintenance" with a menu bar containing "Go To" and "Actions". The main area contains the following fields:

- Quality Order: 1003
- Item Number: WLT18-P1
- Unit of Measure: EA
- Type: 1
- Site: 10000
- Auto Issue:
- Batch: 5
- WIP Lot Std Rep
- Parent 1
- Quantity Pending: 100.0
- Quantity Accepted: 0.0
- Quantity Rejected: 0.0
- Status: c
- PO/Job:
- Project:
- Remarks:
- Start Date: 02/27/2007
- Release Date: 02/27/2007
- Due Date: 02/27/2007
- Effective Date: 02/27/2007
- Procedure: test

Operation lead time indicates the time, stated in decimal hours, this test operation normally takes. Operation time is independent of the number of units being tested. Make sure you enter it consistently as either time per unit or time per test batch.

**Note** There is no integration between quality procedures and capacity requirements plan (CRP).

You can link each operation of a procedure to one or more items in the Procedure Supplies pop-up frame. These items are consumed during testing or inspection, and are issued from inventory. They are not issued to WIP, but are treated as floor stock and expensed to cost of production when quality orders are processed.

## Defining Sampling Patterns

Define sampling patterns for items in inventory in Sampling Pattern Maintenance (19.3.1). Patterns can be defined so that an audit selects inventory based on expiration dates or lot interval.

See "Inventory Audits" on page 237 for more details.

*Days to Expire.* Specify the number of days prior to expiration an item is to be sampled.

You can specify different sampling criteria for each item, either on a regular interval or prior to expiration. Sample by Lot Interval Inquiry (19.3.14) reviews items based on the first criteria, and Sample by Expire Days Inquiry (19.3.13) reviews items based on the second. Both print in sequence by item number.

When sampling by days to expire, the system reviews all of the inventory details for this item, and selects any that are due to expire within this number of days.

Sampling by Days to Expire is only useful for items with limited shelf life, as defined in Item-Site Inventory Data Maintenance (1.4.16) or Item Master Maintenance (1.4.1).

*Lot Interval.* Use this method for sampling items that are stored at more than one site or location *and* that are stored with lot/serial or lot reference numbers. Enter a value *n* to pick every *n*th lot from inventory.

For example, if there are 16 unique inventory records for an item and Lot Interval is 2, Sample by Lot Interval Inquiry (19.3.14) selects every second record, for a total of eight records.

Inventory selection based on a sampling is not automatically entered into a quality order. You must run Sample by Expire Days Inquiry or Sample by Lot Interval Inquiry to see which items are to be sampled.

## Executing Stand-Alone Tests

Use quality orders to conduct stand-alone inspections of incoming material or material already in inventory. A quality order authorizes a test or inspection and specifies how much to test, where, when, and how. After testing, enter results in Quality Order Results Entry (19.11).

The immediate effect of a quality order is to transfer material from its current inventory location to an inspection location at the same site. This is where the procedure designated on the quality order is run, and test results recorded. Quality orders link:

- The quantity of an item
- A set of testing procedures, and
- A set of test specifications for those procedures

**Fig. 11.6**  
Quality Orders

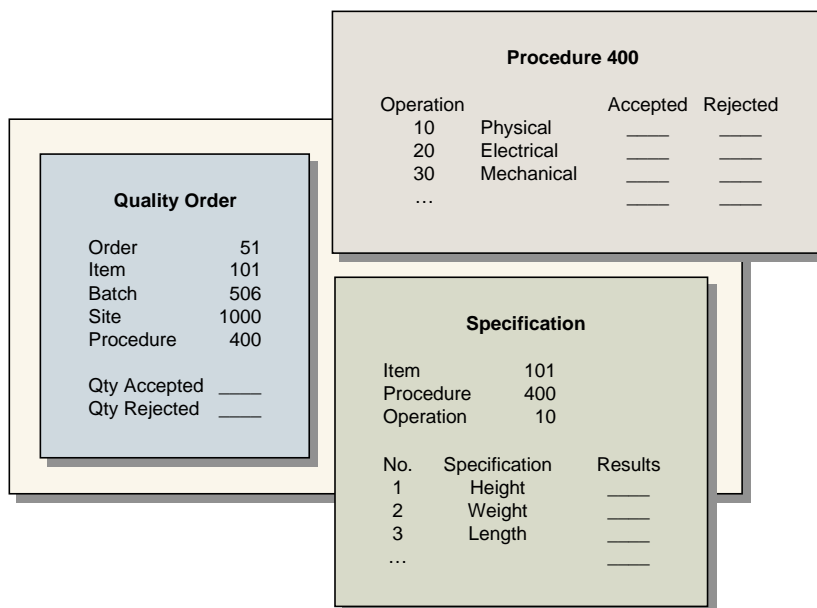

You can use quality orders to manage inspection of incoming materials. When material arrives at a receiving location, create a quality order to transfer the material to an inspection location. After inspection, the accepted material is transferred to inventory. Rejected material is issued from the inspection location and expensed using the product line Scrap account.

**Note** To do this, you must set Inspect to No in Item Planning Maintenance (1.4.7).

## Creating Quality Orders

Create quality orders in Quality Order Maintenance (19.7).

**Fig. 11.7**  
Quality Order Maintenance (19.7)

The screenshot shows the 'Quality Order Maintenance' window with the following data:

Quality Order: 1003	Batch: 5
Item Number: WLT18-P1	WIP Lot Std Rep
Unit of Measure: EA	Parent 1
Type: I	
Site: 10000	
Auto Issue: <input checked="" type="checkbox"/>	
Quantity Pending: 100.0	Start Date: 02/27/2007
Quantity Accepted: 0.0	Release Date: 02/27/2007
Quantity Rejected: 0.0	Due Date: 02/27/2007
Status: c	Effective Date: 02/27/2007
PO/Job:	Procedure: test
Project:	
Remarks:	

*Type.* Specify the type of testing to be done.

**I (Inspection):** The quantity to inspect is transferred to the inspection location specified in Quality Management Control. Any quantity rejected is issued from this location and expensed to the Scrap account. Quantity accepted is transferred back to regular inventory.

**D (Destructive):** The quantity to inspect is transferred to the inspection location, but both accepted and rejected quantities are issued and expensed to cost of production.

*Site.* This site defaults from the inspection site defined in Quality Management Control.

*Auto Issue.* Enter Yes to have supplies required for an inspection automatically issued. The quantity issued is the Quantity Per for the supply item—specified in the associated procedure—multiplied by the change in the quantity pending inspection. Enter No to have supplies issued during Quality Order Results Entry (19.11).

*Quantity Pending.* This is the quantity to be transferred to inspection. If the quantity pending is changed on a quality order, the difference is calculated and transferred, either to inspection or to inventory.

*Quantity Accepted, Quantity Rejected.* These quantities default from Quality Order Results Entry.

*Effective Date.* Enter the date the system should use for GL transactions. The system verifies that the date is in an open GL period.

*Status.* The status of a quality order. Values are either blank, Open, or Closed. An order remains open until quantity pending is zero.

*Procedure.* A quality order can reference a procedure the same way a work order can reference a routing.

## Entering Quality Order Results

Enter results of a test or inspection in Quality Order Results Entry (19.11). This program also moves material out of inspection and issues supplies required by inspection.

**Fig. 11.8**  
Quality Order Results Entry (19.11)

Item Number	Op	Qty Pending	Qty Accepted	Qty Rejected
10074-Master	10	0.0	0.0	0.0

You can record results for an order, for each operation on an order, or for each specification for an operation. For an order, you can record total quantity accepted and rejected. For an operation, you can record quantity accepted and rejected, actual time required for testing, and comments. For each specification, you can enter results and comments.

You can also change the quantity pending for an operation. You might do this if the quantity rejected at a previous operation results in units being scrapped, and thereby made unavailable for inspection at the current operation.

## Deleting Quality Orders

If no results are entered for an order, you can change the quantity pending to zero and delete the order in Quality Order Maintenance. If dispositions or results have been entered, you can close the order and delete it with Quality Order Delete/Archive (19.23).

## Conducting Process Inspections

When inspection occurs in process, work orders and repetitive schedules control the movement of material. Quality orders are not needed.

Process inspections are typically performed on a factory floor. You can do this by defining inspection operations in an item's routing in Routing Maintenance (14.13.1). These operations are linked to test specifications in the same way that test steps in quality orders are linked.

Reporting test results can be part of regular labor reporting. For work orders with routings, enter inspection results in:

- The labor feedback transactions in Shop Floor Control (17)
- For a repetitive schedule, in Repetitive Labor Transaction (18.14)
- For an advanced repetitive schedule, in Backflush Transaction (18.22.13)

For scheduled work orders or work orders without routings, enter test results manually in Test Results Maintenance (19.13). Results entered here are processed in the same way as in Quality Order Results Entry.

Figure 11.9 illustrates how test results are reported as part of labor feedback.

**Fig. 11.9**  
Reporting Test Results in Labor Feedback by Work Order (16.20.1)

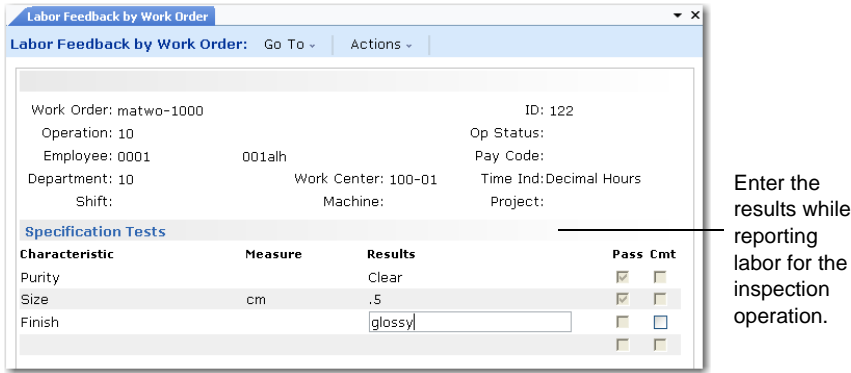

After you enter the quantities accepted and rejected for an operation, the system prompts you to record results and comments. The system compares your entry with the specification for the result. If the result is out of tolerance, a warning displays.

As with quality orders, you can enter only one result per specification. Enter additional information as comments. If you have several samples, you may want to enter the best, worst, or typical case for each group.

During inspection, process material remains in WIP. After an inspection is complete, material moves to the next operation. From the last operation the accepted material is received back into inventory and rejected material is scrapped. Figure 11.10 illustrates the process inspection.

**Fig. 11.10**  
Process Inspection

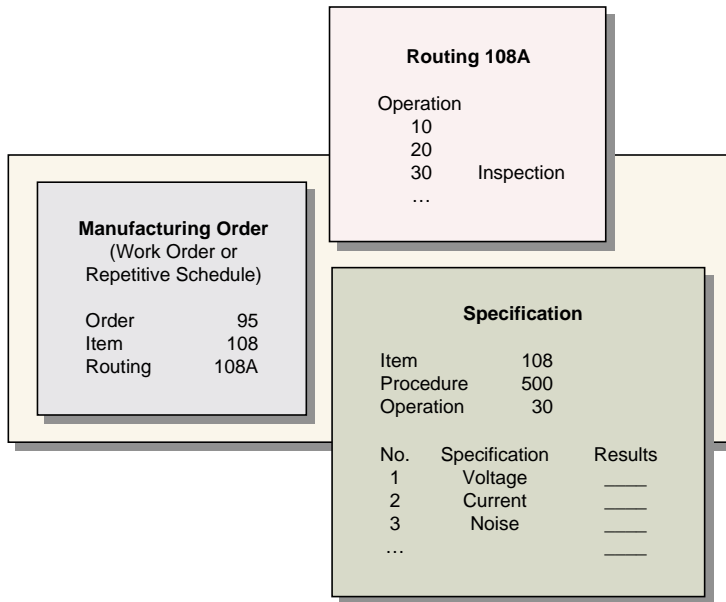

## Conducting Other Tests

You can use quality orders to conduct other specialized kinds of tests.

### Inventory Audits

Material subject to an inventory audit is like material processed by incoming inspection. Both use quality orders, and material never leaves inventory. The difference is that material is selected from inventory for audit based on criteria such as expiration date or item.

Use inventory sampling patterns to determine which items are to be audited. Sampling is based on expiration dates or lot intervals. You can also use Inventory Detail Report (3.6.5) to identify inventory items based on expiration date, site, location, assay percentage or grade.

See “Defining Sampling Patterns” on page 232 for more details.

It is not always practical to move an entire lot from inventory for testing. As an alternative, you can test a sample and leave the remainder in inventory. To prevent these from being issued or transferred before results are available, change the inventory status to a code that restricts issues or transfers.

The quantity for a quality order must reflect the quantity of an item moved to inspection for testing. This quantity is the same as the lot size if an entire lot is moved to inspection, and it is the lot sample size if only a portion is tested.

### First Article Inspection

First article inspections are used to qualify a machine, a tool, or the setup of a machine or tool by determining whether it can produce items within design limits. It is assumed that if a few items can be produced correctly, the machine or tool is set up properly.

First article inspection differs from regular inspection in that it examines a sample by comparing it to most, if not all, of the engineering specifications appropriate for a specific level of processing.

First article inspection and process validation can use either quality orders or in-process inspection. The selection depends on whether or not the units evaluated are obtained from a supplier or from an internal manufacturing process.

### Process Validation

Process validation—an extension of first article inspection—is used to qualify a manufacturing process. Rather than use a single sample or unique lot, process validation requires one or more large batches, each of them a typical manufacturing lot. Samples from the beginning, middle, and end of production can be examined to determine the stability of a manufacturing process and its ability to consistently produce quality material.

Quality orders can handle process validations, since they record inventory transactions and allow unplanned issue of testing supplies.

## Destructive Testing

On a regular quality order, the quantity subjected to destructive testing should be reported in Quality Order Results Entry (19.11) as rejected, regardless of whether it passed or failed. This causes the quantity to be issued from inspection and expensed to scrap.

The lot quantity subjected to destructive testing can have its own quality order with a type code of D. When results are entered, quantities accepted and rejected are issued from inspection and expensed to cost of production.

For process inspection, there is no special provision for destructive testing. If rejected or scrapped quantities exist at an inspection operation, they remain in WIP. Quantities are taken out of WIP when received or rejected by a work order receipt function or by Repetitive Labor Transaction (18.14) or Backflush Operation (18.22.13). Nonconforming components can be returned from WIP by processing a Work Order Component Issue (16.10) for a negative quantity.

## Printing Test Results

Print test results for quality or manufacturing orders with Certificate of Analysis Print (19.20). An option to disregard the test results lets you print a certificate whether or not an order has passed all specifications. Printing certificates for materials that have failed to meet specifications provides a record when dispositioning non-conforming material. The certificate can be attached to the material and used as data entry to take the material out of inventory.

# Forecasting/Master Schedule Planning

This Forecast/Master Schedule Planning module lets you create and maintain shipment forecasts and master production schedules.

Using functions in the Forecast/Master Schedule Planning module, you can calculate and record the number of units of a given item you expect to ship each week from a given site.

These forecasts are used to develop the master production schedule and drive material requirements planning (MRP).

Forecasts and master schedules can be created for any item, but are usually created for end items, critical subassemblies, and service parts.

## ***Creating Forecasts*** 240

Outlines how to create a forecast manually or in simulation, how to edit and maintain forecast data, and how to make it available to MRP.

## ***Consuming Forecasts*** 255

Defines consuming a forecast and details how aspects of the forecast impact MRP and scheduling.

## ***Creating Master Production Schedules*** 257

Defines a Master Production Schedule (MPS) and lists what is necessary for MPS generation.

## Creating Forecasts

You can create shipment forecasts using one of the following methods:

- Use the forecasting simulation functions to calculate item forecasts using sales history data and the forecast method you specify. See page 240.
- Use the CIM interface to load externally generated forecasts into forecast detail records in your database. See page 247.
- Use Forecast Maintenance (22.1) or Forecast Worksheet Maintenance (22.2) to manually enter forecasts. See page 254.
- Use Simulation-to-Simulation Copy (22.7.11) or Single Item Simulation Copy (22.7.12) to create new forecasts based on existing forecasts. See page 248.

### Forecast Creation Workflow

- 1 Create a criteria template.
- 2 Do one of the following to create a forecast detail record.
  - Run the simulated forecast calculation.
  - Manually enter a forecast generated outside of the system.
- 3 Manually modify forecast detail records as needed.
- 4 Optionally copy or combine detail forecast records.
- 5 Generate reports to review the cost, price, and profit margin for monthly forecast quantities.
- 6 Load the detail forecast records into summary forecasts to become a source of demand for MRP.
- 7 If required, manually create forecasts or adjust quantities for forecasts generated by forecast simulation functions using Forecast Maintenance (22.1) or Forecast Worksheet Maintenance (22.2).
- 8 Run MRP.

### Forecasting Simulation

Forecasting simulation functions enable you to analyze sales shipment history, calculate forecasts, and update demand for material requirements planning (MRP), creating a closed-loop system.

Forecasting simulation functions generate forecasts based on shipment history. They use statistical methods and extrapolation techniques to evaluate underlying patterns in sales history data and predict future demand.

Forecasting assumes that historical sales patterns are repeated to varying degrees in the future. The accuracy of any forecast depends on the value of the sales information used to create it. The more sales history available, the more accurate the forecast.

Figure 12.1 outlines the flow of information in forecasting simulation functions.

**Fig. 12.1**  
Forecasting Simulation Information Flow

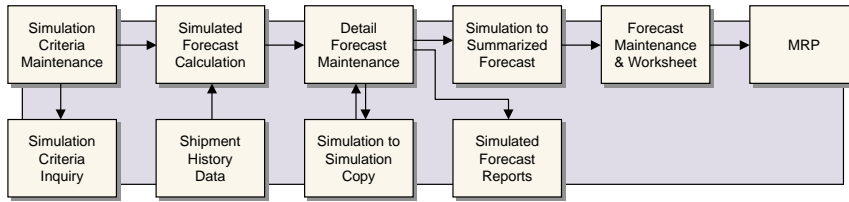

## Forecasting Horizon

Forecasts generated using forecasting simulation functions are produced in monthly buckets. They can either be for a given year or for the next 12 months, beginning with the current month. The latter is called a *rolling forecast*.

To produce a forecast for a given year, you must specify a forecast ending year that is earlier than the forecast year. To produce a 12-month rolling forecast beginning in the current month, the ending year must be the same as the forecast year.

**Note** The system defines the first week of a new calendar year as the first Thursday in January, in accordance with ISO standards.

## Setting Up Forecasting Simulation

Forecasting simulation programs analyze shipment history data in the customer-product sales history (cph\_hist) table. For shipment history to post to cph\_hist, Integrate with SA must be Yes in Sales Order Control (7.1.24).

## Creating Criteria Templates

Producing a forecast begins with defining a criteria template. Criteria templates indicate which sales history to analyze and how the system should perform the forecast calculation. You can define criteria templates using Simulation Criteria Maintenance (22.7.1), or use Simulated Forecast Calculation (22.7.5) to define them at the time of forecast calculation.

Once you use a criteria template in a forecast calculation, you cannot modify it using Simulation Criteria Maintenance. However, you can modify previously used criteria templates when performing forecast calculations in Simulated Forecast Calculation.

**Fig. 12.2**  
Simulation Criteria Maintenance (22.7.1)

**Forecast Year.** For a rolling forecast starting this month, this year must be identical to the ending year. See “Forecasting Horizon” on page 241.

**Years of History.** Specify the number of years of shipment history to analyze, up to five years. The system reduces this number if there are no sales data for a given year.

**Ending.** Ending year must be the same as or earlier than the forecast year.

**Forecast Method.** Specify either a predefined forecast method (01–06) or your own forecast method. See “Forecast Methods” on page 243.

**Alpha factor, Trend, User factor [1] and [2].** Specify weighting factors used by the forecast method. See “Alpha and Trend Factors” on page 245.

**Item Number, Product Line, Group, Item Type.** Use these fields to identify a single item or range of items for which to forecast.

**Order Line Site.** Specify the order line site on sales orders or ship-from site on a customer schedule, used to further define items to forecast.

**Use Ship-To/Sold-To.** Indicate whether the system selects sales history to analyze based on the customer’s ship-to or sold-to address.

**Customer, Region, List Type.** Use these fields to identify subsets of customers for which the system selects sales data to analyze.

**Note** When you specify both Ship-To and Region as criteria for selecting sales history data, only permanent ship-to addresses—that is, those defined for customers in Financials—are in the selected region range.

## Demand Patterns

Sales history can contain four underlying patterns of demand. Forecasting methods quantify these patterns.

**Table 12.1**  
Demand Patterns

Pattern	Description	Example
Trend	Sales quantities increase or decrease over time.	The growth pattern of a new product.
Seasonal	Sales quantities fluctuate according to some seasonal factor, such as weather or the way a firm handles its operations.	Sales of soft drinks, which increase in the summer months.
Cyclical	This pattern is similar to seasonal, but the length is greater than one year. The pattern does not repeat at constant intervals and is the hardest to predict.	The sale of houses.
Horizontal	Sales quantities do not increase or decrease substantially.	A stable product with consistent demand.

Figure 12.3 shows examples of these demand patterns in graph format.

**Fig. 12.3**  
Demand Patterns

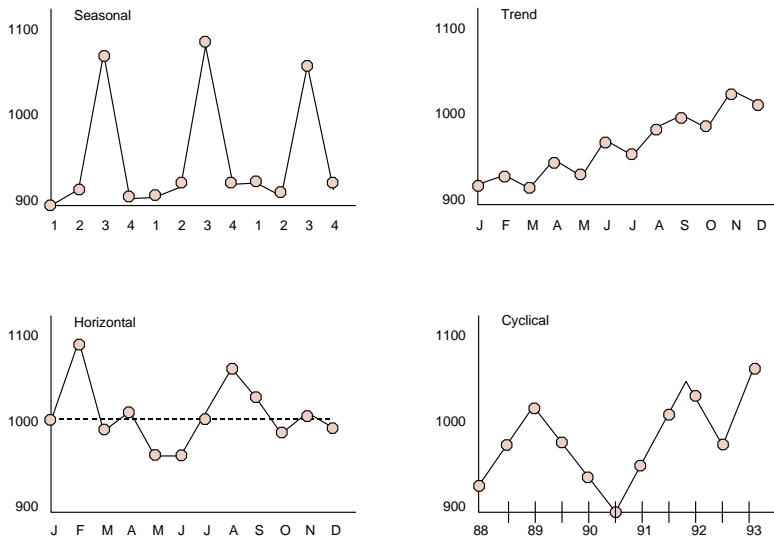

**Forecast Methods**

Forecast methods are identified by two-digit method numbers. Table 12.2 lists the forecast method numbers available.

**Table 12.2**  
Method Numbers

Method Number	Usage
00	Indicates that a forecast detail record was not generated by the system, but was created manually using the copy programs or using CIM interface.
01–06	Predefined forecast methods.

Method Number	Usage
07–50	Reserved for QAD usage.
51–99	Use these numbers to identify your own forecasting methods.

There are six predefined forecast methods, described in Table 12.3. You can create additional methods using User Forecast Method Maintenance (22.7.17).

See page 245.

**Table 12.3**  
Predefined Forecast Methods

Method #	Type	Description
01	Best Fit	Uses all predefined methods—02 through 06—and selects the results with the least mean absolute deviation. This is the default forecast method.
02	Double Moving Average	The simplest of the forecasting techniques. It uses a set of simple moving averages based on historical data and then computes another set of moving averages based on the first set. The moving averages are based on four months of data. This method produces a forecast that lags behind trend effects.
03	Double Exponential Smoothing	The most popular of the forecast techniques. It is similar to Double Moving Average, except that it uses the alpha factor to weigh the most recent sales data more heavily than the older sales data. This method produces a forecast that lags behind trends effects.
04	Winter's Linear Exponential Smoothing	Produces results similar to Double Exponential Smoothing, but incorporates a seasonal/trend adjustment factor. This method can be used to forecast based on sales history containing both trends and seasonal patterns. Uses the trend and alpha factors. Requires two years of history.
05	Classic Decomposition	Recognizes three separate elements of demand patterns in sales history: trend, seasonal, and cyclical factors. See Table 12.1 on page 243 for information about demand patterns.  Classic Decomposition is usually the preferred method for forecasting seasonal, high-cost items. It requires at least two years of history.
06	Simple Regression	Also called the least squared method, this method analyzes the relationship between sales and time span to ensure that the forecast quantity is equally likely to be higher or lower than the actual quantity sold. Useful for products with a stable history, or horizontal demand pattern.

Table 12.4 shows each of the predefined forecast methods and indicates the sales patterns they are typically used to quantify, the number of years of shipment history required for calculation, and whether they use alpha and trend factors.

**Table 12.4**  
Overview of Forecast Methods

	01	02	03	04	05	06
Cyclical					Yes	
Trend		Lags	Lags	Yes	Yes	
Seasonal				Yes	Yes	
Horizontal						Yes
Years of History	1	1	1	2	2-3	1
Trend Factor				Yes		
Alpha Factor			Yes	Yes		

### Alpha and Trend Factors

Some forecast methods use alpha and trend factors to weight shipment history when calculating forecasts.

When method 03 or 04 is used to calculate forecasts, alpha factors determine the relative importance given to more recent sales history. For new products with rapidly changing sales quantities, you may want to enter an alpha value closer to one to give more weight to recent sales history. However, for products with long and stable sales histories, you might specify a smaller alpha value to produce smoother forecast results.

When method 04 is used to calculate forecasts, trend factors determine the relative weight given to sharp increases or decreases in sales history when calculating forecasts.

Table 12.5 shows the effects of alpha and trend factors on forecasting calculations. Alpha and trend values must be between zero and one.

**Table 12.5**  
Alpha and Trend Factors

Factor	Zero	One
Alpha Factor	Equal weight on all history	Weighs recent history
Trend Factor	Ignores sharp changes in history	Weighs heavily sharp changes in history

### Creating Additional Forecast Methods

Forecast methods identify the Progress program the system uses to calculate forecasts. Different programs employ different statistical methods.

You can create specialized forecast methods for the system to use in producing forecast quantities. User Forecast Method Maintenance (22.7.17) lets you add your forecast methods, in the form of Progress programs you supply, to the existing forecast methods.

The criteria template includes two variables that can be set to interact with your own forecast method: User factor1 and User factor2. These are reserved for your forecast methods and do not operate with any of the predefined methods.

For user-defined forecast methods:

- The name of the program must be `ffcalcXX.p` where `XX` is a forecast method number between 51 and 99.

- The Progress program must be written and accessible to the system before you can define the method number in User Forecast Method Maintenance.
- Your Progress program must use an array named `calc[1-60]` for the historical data input and an array named `fcst[1-12]` for the calculated output.
- Your Progress program must include the following files at the beginning of the program: `fcavar.i` and `ffvar.i`.

Compare your forecast method program to the existing programs `ffcalc[02-06].p`, as needed.

## Calculating Forecasts

Run forecast calculations using Simulated Forecast Calculation (22.7.5).

**Fig. 12.4**  
Simulated Forecast Calculation (22.7.5)

Simulated Forecast Calculation analyzes an item's shipment history data and produces a forecast detail record that predicts what quantity of the item will be sold in the future.

This calculation requires a criteria template. You can either specify a criteria template defined in Simulation Criteria Maintenance (22.7.1) in the Forecast ID field or define a new criteria template at this time.

See “Creating Criteria Templates” on page 241.

When insufficient shipment history exists to generate a valid forecast for an item, the detailed forecast record for that item is created for a quantity of zero. Negative results also display as zero quantities.

**Note** At least one sales record is required to produce a nonzero forecast quantity.

Running Simulated Forecast Calculation generates sales predictions for each specified item for a one-year period. If you specify an entire product line, product type, or product group for which to forecast, each individual item is forecasted separately. Also included in the report are the number of items calculated and insufficient items—that is, items that lack enough historical data to generate an accurate forecast.

The calculated forecast quantities are stored in forecast detail records, identified by the forecast ID, year, and item. You can manually modify forecast detail records as needed.

**Note** You must enter forecast detail records created outside the system manually using Detail Forecast Maintenance (22.7.7) or load them using the CIM interface. See “Manually Creating Forecasts” on page 247.

When you run a forecast calculation, any existing criteria templates or forecast detail records with the same forecast ID are automatically deleted.

Criteria templates used to calculate forecasts can be further modified only when doing another calculation using Simulated Forecast Calculation.

## Manually Creating Forecasts

You can use Detail Maintenance Forecast (22.7.7) to manually create forecast detail records.

**Note** You cannot manually create a rolling forecast.

When loading forecast results using the CIM interface or manually entering forecasts using Detail Forecast Maintenance, you must specify a forecast ID, year, and item number. The system automatically sets the forecast method to 00 and generates a criteria template, which is stored under the same forecast ID as the detail record.

See *User Guide: QAD System Administration* for information about the CIM interface.

## Modifying Forecast Results

Forecast quantities may require modification to be more reflective of future market demand. This is especially true when forecast results are based on historical data that included unprecedented sales—for example, sales due to a sales promotion or a natural disaster. When you believe that future demand will not be similar to sales history, you can adjust existing forecast detail records accordingly.

**Note** Modify forecast detail records as needed *before* copying forecast quantities to the summary forecasts used by MRP.

You can use Detail Forecast Maintenance (22.7.7) to modify forecast detail records produced by forecast calculations or loaded into the system using the CIM interface.

**Fig. 12.5**  
Detail Forecast Maintenance (22.7.7)

Year	Month	Original Forecast	Adjusted Forecast
2007	January	2000	2000
2007	February	2000	2000
2007	March	2000	2000
2007	April	2050	2050
2007	May	2200	2200
2007	June	2500	2500
2007	July	2700	2700
2007	August	3000	3000
2007	September	2700	2700
2007	October	2500	2500
2007	November	2050	2050
2007	December	2000	2000
	Total	27,700	27,700

Select a forecast detail record to modify by specifying a forecast ID and forecast year. To select a forecast detail record created for a product group, you must also specify an item number.

Forecast detail records display in three columns:

- Month
- Original Forecast
- Adjusted Forecast

The quantities in the Orig. Fcst column are the original forecast quantities, either the result of the system forecast calculation or the original quantity you manually entered or loaded.

You can modify the forecast as needed by changing the quantities in the Adjusted Forecast column.

**Warning** All changes to forecast detail records are permanent. To reproduce original forecasts, you must rerun the forecast calculation. Before modifying forecast detail records, you should archive the original forecast or copy it to another forecast ID.

## Copying and Combining Forecasts

To create new forecasts by copying or combining existing detail records, use Simulation to Simulation Copy (22.7.11) or Single Item Simulation Copy (22.7.12).

**Fig. 12.6**  
Simulation to Simulation Copy (22.7.11)

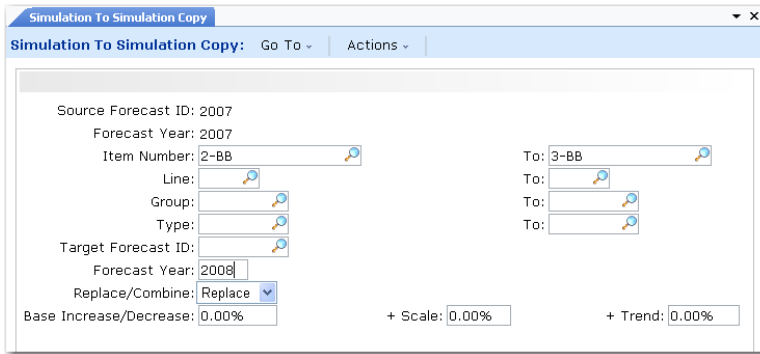

These functions let you copy, replace, or combine forecast detail records. With Simulation to Simulation Copy, you can copy forecast records for multiple items in a single transaction, whereas with Single Item to Simulation Copy you can copy only for a single item.

**Note** To manually adjust forecast detail records created using these functions, use Detail Forecast Maintenance (22.7.7). See “Modifying Forecast Results” on page 247.

**Multipliers**

When copying or combining forecast detail records using Simulation to Simulation Copy (22.7.11) or Single Item Simulation Copy (22.7.12), you can apply multipliers to the resulting forecast quantities. Multipliers, also called multiplicative factors, allow you to increase, decrease, or scale forecast quantities by a specified percentage. Multipliers can be useful when you have prior knowledge of an unscheduled demand, such as a future sales promotion.

There are three types of multipliers:

- Base Increase/Decrease
- Scale
- Trend

In Single Item Simulation Copy, multipliers let you scale the forecast results for a new item as some percentage of an old item. This is useful when you want to match the seasonal demand, but not the quantity, of an old item for a new item.

Simulation to Simulation Copy lets you apply multipliers to a range of items.

*Base Increase/Decrease.* The percentage by which a forecast quantity is increased or decreased. A negative percentage indicates that the quantity is decreased.

**Table 12.6**  
Base Increase/ Decrease Multiplier

Month	Units	10%	-10%
January	100	110	90
February	150	165	135
March	120	132	108

*Scale.* The percentage by which a forecast quantity is multiplied, or scaled. This value cannot be negative.

**Table 12.7**  
Scale Multiplier

Month	Units	10%	-10%
January	100	10	n/a
February	150	15	n/a
March	120	12	n/a

*Trend.* The percentage by which a forecast quantity increases each month. A negative percentage decreases the quantity over time.

**Table 12.8**  
Trend Multiplier

Month	Units	10%	-10%	
January	100	110	90	= 100 +/- (100 * 10%)
February	150	180	120	= 150 +/- (150 * 20%)
March	120	156	84	= 120 +/- (120 * 30%)

You can use more than one multiplier at a time. The effect of multiple factors is cumulative. Base Increase/Decrease is applied first, Scale second, and Trend third.

When you are replacing an existing detail record and apply multipliers to the source quantities, the results overwrite the quantities in the target detail record.

When you are combining records and use a multiplier, the multiplier is applied to the source quantity and the result added to the target quantity. The factor is *not* applied to the combined source and target quantity.

### Simulation To Simulation Copy

Use Simulation to Simulation Copy (22.7.11) to copy an existing forecast detail record to another forecast ID or to combine several forecast detail records into a single detail record.

To use this function, you must specify a source forecast ID identifying the forecast detail record to copy to or combine with the target record, and a target forecast ID identifying the forecast detail record to which the source information is copied. A criteria template must exist for the specified source forecast ID.

The target forecast ID you specify does not need to correspond to an existing forecast detail record or criteria template. If a corresponding record does exist for the specified target ID, its forecast method must be 00. If no such record exists, the system creates a target forecast detail record with a method of 00.

If you want to copy detail records for a subset of the items in the source record, you can also specify an item range to be copied.

**Note** If the item ranges for the target and source records differ, then the target record's range is expanded.

The system combines or copies forecast records only in terms of item units. The Combine/Replace field indicates whether to replace the target forecast quantity with the source quantity or combine the target and source quantities. When you combine forecast quantities, the quantity for an item in

the source detail record is added to the quantity for that item in the target detail record. When you replace forecast quantities, the quantity for an item in the source record replaces the quantity for that item in the target detail record.

**Note** You cannot separate combined forecast records.

You can increase, decrease, or scale the resulting detail record, or multiply the detail record by a trend factor.

See “Multipliers” on page 249 for details.

Using this function to copy or combine forecast detail records automatically deletes the original, or target, forecast record and replaces it with the copied or combined record. The source detail record and criteria template remain unchanged.

### Single Item Simulation Copy

Single Item Simulation Copy (22.7.12) enables you to create a forecast for a single item based on the historical sales data for another item. Since there is often little or no sales history for new items, you may want to use the demand history for a similar product to produce forecasts for a new product.

**Note** If the Target Forecast ID, Item Number, or Forecast Year fields are left blank, the system sets them to the target values.

You must specify an item number to copy from the source detail record. This item must exist in the item master.

Forecast records are copied only in terms of units. The source and target items must have identical units of measure, or a unit of measure conversion must exist.

If the specified target forecast detail record already exists in the system, its forecast method must be 00. If the target does not exist, the system creates a forecast detail record with a method of 00.

When copying forecast records, forecast amounts can be multiplied by a Base Increase/Decrease, Scale, or Trend factor.

See “Multipliers” on page 249.

During a combine or replace, the original target forecast record and criteria template are overwritten. The source record is not altered.

### Generating Reports

The system does not generate forecasts in currency values. However, Detail Forecast Report (22.7.9) lets you review forecast quantities along with the production cost and sales price by month. You must specify the cost set, site, price list, and currency in which to display the monetary amounts.

If both the cost and price are in the same currency, the report displays the profit margin, calculated as price minus cost. The number of units, the extended cost value, and the extended price value are also totaled for the entire 12-month reporting period.

Table 12.9 illustrates a sample forecast report, assuming the forecasted item has a unit cost of \$15.36 and a unit price of \$25.00.

**Table 12.9**  
Sample Forecast Report

Forecast ID	Year	Item No.	Mo.	Units	Ext Cost	Ext Price	Margin
j205095	2002	j2050	Jan	1336	20,520.96	33,400.00	12,879.04
			Feb	1568	24,084.48	39,200.00	15,115.52
			Mar	1839	28,247.04	45,975.00	17,727.96
			Apr	1970	30,259.20	49,250.00	18,990.80
			May	2182	33,515.52	54,625.00	21,109.48
			Jun	1995	30,643.20	49,875.00	19,231.80
			Jul	2003	30,766.08	50,075.00	19,308.92
			Aug	2134	32,778.24	53,350.00	20,571.76
			Sep	1984	30,474.24	49,600.00	19,125.76
			Oct	1781	27,356.16	44,525.00	17,168.84
			Nov	1634	25,098.24	40,850.00	15,751.76
			Dec	1457	22,379.52	36,425.00	14,045.48
Total				21883	336,122.88	547,075.00	210,952.12

## Making Forecast Data Visible to MRP

Forecasts generated using forecast simulation functions or loaded into forecasting simulation functions using the CIM interface are stored in forecast detail records, whereas MRP uses summary forecast records to drive its demand calculations.

Use Simulation to Summarized Forecast (22.7.13) to load forecast quantities into the summary forecast records used by MRP. This program uses the forecast detail records to create new summary forecast records, replace old summary records, or combine with existing summary forecasts.

See Chapter 13, “Material Requirements Planning,” on page 267.

**Fig. 12.7**  
Simulation to Summarized Forecast (22.7.13)

Simulation To Summarized Fcst: Go To ▾ Actions ▾

Forecast ID: 2007  
Forecast Year: 2007  
Item Number: 2-BB  
Line:   
Group:   
Type:   
Summarized Site: 10000  
Loading Method: 1  
Start: 03/05/2007  
Replace/Combine: Replace  
Update:

To: 3-BB  
To:   
To:   
To:

Autospread

Output:  
Batch ID:

Forecast detail records are identified by forecast ID, year, and item, whereas summary forecast records are identified by item, site, and year.

Since MRP is site-specific, you must specify a summary site to update. This site may be different from the order line site specified on the criteria template. When a forecast is for a group of items, you can generate summary forecast records for one item, a subset of items, or all items in the detail record.

See “Creating Criteria Templates” on page 241.

Forecast detail records are copied to summary forecasts only in terms of units.

**Note** You can combine multiple detail records into one summary forecast, but this is not recommended, since the combined result is not a valid forecast.

Updates to the summary forecasts are permanent and cannot be undone. You should run Simulation to Summarized Forecast in report mode before performing the update.

You can manually modify summary forecast quantities as needed, using Forecast Maintenance (22.1) or Forecast Worksheet Maintenance (22.2).

See page 254.

### Loading Methods

When loading forecast detail records into summary forecasts, you can specify one of three loading methods that the system uses to break the monthly forecast quantities into the weekly quantities used by MRP.

The three loading methods are:

- *Autospread (1)*. Monthly forecasts are broken into daily averages and summed into weekly buckets starting on Monday. Unless the day that you are loading forecast is a Monday, the loaded forecast begins on the following Monday. This is the default loading method.
- *Load Last Week (2)*. Monthly forecast is loaded into the last Monday of the forecast month.
- *Load First Week (3)*. Monthly forecast is loaded into the first Monday of the forecast month.

### Deleting and Archiving Forecasting Detail Records

Use Detail Forecast Delete/Archive (22.7.23) to delete forecasting detail records or archive them to file as needed. You can also delete and archive criteria templates.

## Maintaining Forecasts Outside of Forecast Simulation

If you need to manually enter or modify item shipment forecasts outside of forecasting simulation functions, use Forecast Maintenance (22.1) or Forecast Worksheet Maintenance (22.2).

**Fig. 12.8**  
Forecast Worksheet Maintenance (22.2)

Week	Forecast	Sales	Abnormal	Prod Fcst	Net Forecast
1 01/01/2007	2,000	0	0	0	0
2 01/08/2007	2,000	0	0	0	0
3 01/15/2007	2,000	0	0	0	0
4 01/22/2007	0	0	0	0	0
5 01/29/2007	0	0	0	0	0
6 02/05/2007	0	0	0	0	0
7 02/12/2007	0	0	0	0	0
8 02/19/2007	0	0	0	0	0
9 02/26/2007	0	0	0	0	0
10 03/05/2007	0	0	0	0	0
11 03/12/2007	0	0	0	0	0
12 03/19/2007	0	0	0	0	0
13 03/26/2007	0	0	0	0	0
Totals	0	0	0	0	0

Forecast quantities entered using these functions display in weekly buckets and appear as a demand requirement for the Monday of that week.

To create new item forecasts for a given site and year, enter expected weekly shipment quantities expressed in the item's unit of measure.

You should forecast at least as many weeks as are required to cover the cumulative lead time of the item, which is the maximum time it takes to produce that item if none of its lower-level components are in stock. Forecasting an item based on cumulative lead time ensures sufficient time to respond to changes in the requirements for that item.

**Note** Shipment forecasts do not represent the quantity of incoming orders, but rather the quantity expected to be shipped during a one-week period.

Forecast Worksheet Maintenance (22.2) includes the following display fields:

*Forecast.* The shipment forecast for a given week.

*Sales.* The quantity of an item on confirmed sales orders and required ship schedules to be shipped this week.

*Abnormal.* Confirmed sales for this week that should not consume forecast. See page 255.

*Production Forecast.* A system-calculated forecast quantity used in multilevel master scheduling. See page 259.

*Net Forecast.* The total forecast quantity seen as demand by MRP. See Chapter 13.

## Consuming Forecasts

MRP and master production scheduling use shipment forecasts to calculate net forecasts. This is done by consuming the forecast—that is, subtracting sales order demand from the shipment forecast. MRP and master production scheduling then use the calculated net forecasts to determine gross item requirements.

See Chapter 13, “Material Requirements Planning,” on page 267.

### Sales Order Demand

Sales order demand is the quantity of an item sold, as recorded on confirmed sales orders or required ship schedules. The system recognizes item quantities ordered as demand when a sales order has been confirmed—that is, Confirmed is Yes in Sales Order Maintenance (7.1.1) or a customer planning or shipping schedule has been changed to a required ship schedule using Required Ship Schedule Update (7.5.5) or Selective Required Ship Schedule Update (7.5.6).

**Note** Confirmed issue lines on service return material authorizations (RMAs) and material order lines (MOs) in the Customer Services module are treated like sales order lines.

Sales order demand consumes shipment forecasts based on the item number, site, quantity, and due date recorded on the sales order or customer schedule.

### Abnormal Sales Demand

Sales order demand is considered abnormal if the quantity or source of demand is not characteristic of quantities anticipated by the current forecast and it should not be used to plan forecasts in the future.

You can designate sales order demand as abnormal by setting the Consume Forecast option to No for that sales order or customer schedule line. Abnormal sales demand is added to the net forecast rather than being subtracted from the shipment forecast.

### Net Forecast Calculation

Master production scheduling and MRP use the net forecast and abnormal sales order demand to calculate total demand. The net forecast is calculated as follows:

$$\text{Net Forecast} = \text{Forecast} - \text{Sales Order Demand}$$

**Note** When the shipment forecast is oversold—that is, the quantity sold exceeds the forecast amount, the net forecast will not go below zero.

### Forward and Backward Forecast Consumption

Typically, shipment forecasts are more accurate over a month than over a week. You can lessen the effects of inaccurate forecasts using forward and backward consumption.

Confirmed sales order and required ship schedule quantities automatically consume forecast in the week they are due. However, if there is no remaining unconsumed forecast for that week, the system can be set to consume remaining forecast quantities for a number of weeks before or after that week.

You can specify the number of forward and backward weeks over which to consume using the Consume Forward and Consume Back fields in Sales Order Control (7.1.24). The system consumes forecast first by going back, then forward, one period from the original forecast period. Consumption continues alternately backward and forward until the specified number of previous and future periods is exhausted. If there are sales quantities still left over, MRP recognizes them as additional demand.

MRP and master schedule planning recognize prior period unconsumed forecast as demand for the number of weeks specified in Consume Back.

If the Consume Back and Consume Forward values change, the system automatically recalculates the net forecast based on the changes.

Figure 12.9 shows an example for which the Consume Forward and Consume Back values in Sales Order Control are both 2 weeks.

- Excess sales in week 2 consume the forecast in week 1.
- Excess sales in week 3 consume the forecast in week 4, then week 1.
- Excess sales in week 5 consume the forecast in week 4, then week 7.
- Excess sales in week 6 consume the forecast in week 7.

**Fig. 12.9**  
Forecast Consumption

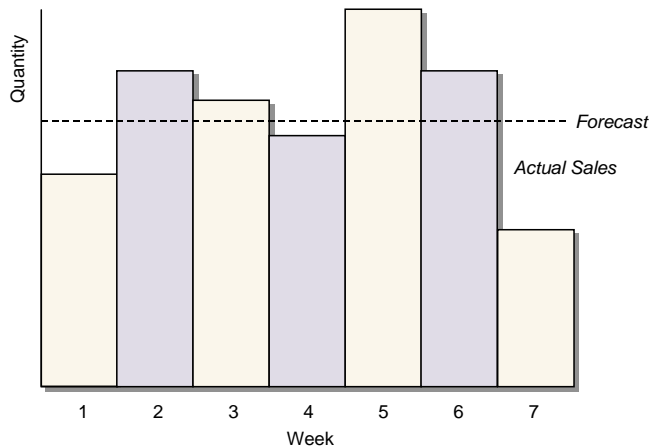

### MRP and Prior Period Forecasts

When you set up the system to consume forecast in previous periods, MRP recognizes prior period unconsumed forecast as additional demand in the current period. When this occurs, you can:

- Delete the forecast for prior periods.

This assumes that if the forecast was not fully consumed for a prior period, it was faulty and should not be considered additional demand for the current period. Use this approach to avoid manufacturing excess inventory for items for which demand will not be generated in the near future.

- Make no changes to the prior period forecast.

This assumes that unsold inventory will be shipped to fulfill future demand exceeding the current, and possibly future, forecast.

- Update the forecast for future periods.

When prior period forecasts are undersold, you can revise forecasts for future periods to reflect the difference.

Master schedulers typically use a combination of these techniques. For example, past due forecasts may be maintained for four weeks and then deleted, whereas forecasts for future periods may be reviewed and updated once a month.

## Creating Master Production Schedules

Master schedulers use detailed forecasts to determine what to produce, when to produce it, and in what quantities. These three things define a statement of production that becomes the master production schedule (MPS).

### Master Scheduled Items

Master schedule items are typically end items, critical subassemblies, spares, service items, critical components, or key resources.

To define an item as master scheduled, set Master Schedule to Yes for that item in Item Master Maintenance (1.4.1), Item Planning Maintenance (1.4.7), or Item-Site Planning Maintenance (1.4.17) for multisite environments.

### Approaches to Master Scheduling

There are several possible approaches to creating and managing master production schedules, each allowing a different amount of control by the system:

- Fully automatic
- Fully manual
- Computer-assisted

#### Fully Automatic Scheduling

The master schedule can be generated entirely by MRP. This means that the system has complete control over master scheduled items, with no distinction between master scheduled and MRP items.

See Chapter 13, “Material Requirements Planning,” on page 267.

**Note** When this approach is used, material plans may change dramatically each time MRP is run. For example, a master schedule order may be expedited one day and canceled the next.

To use the fully automatic approach to master scheduling items, set the following values for each master scheduled item in Item Master Maintenance (1.4.1) or Item Planning Maintenance (1.4.7).

*Master Schedule.* Yes.

*Plan Orders.* Yes.

*Order Policy.* Any option other than blank.

## Fully Manual Scheduling

The master schedule can be created and maintained entirely by a master scheduler, who enters firm planned orders using Master Schedule Order Maintenance (22.13) or Work Order Maintenance (16.1). MRP can be set up to generate action messages to assist the master scheduler in creating orders for master scheduled items.

See Chapter 13, “Material Requirements Planning,” on page 267.

To have MRP review master scheduled items and produce action messages, but not plan orders, for those items, set the following values for each master scheduled item in Item Master Maintenance (1.4.1) or Item Planning Maintenance (1.4.7).

*Master Schedule.* Yes.

*Plan Orders.* No.

*Order Policy.* Any option other than blank.

**Note** If an item’s Order Policy is blank, MRP does not generate action messages for that item.

## Computer-Assisted Master Scheduling

By defining time fences for master scheduled items, you can let MRP control orders outside of a specified time period and allow the master scheduler to control orders within that time period. To use this approach to master scheduling, specify a planning horizon, in calendar days, for each master scheduled item in the Time Fence field in Item Master Maintenance (1.4.1) or Item Planning Maintenance (1.4.7). When MRP plans orders for these items, it will not schedule order due dates within this time fence.

See Chapter 13, “Material Requirements Planning,” on page 267.

**Note** The time fence for an item should generally be equal to the cumulative lead time for that item.

To use the computer-assisted approach for master scheduling, set the following values for each master scheduled item in Item Master Maintenance (1.4.1) or Item Planning Maintenance (1.4.7).

*Master Schedule.* Yes.

*Plan Orders.* No.

*Order Policy.* Any option other than blank.

*Time Fence.* The cumulative item lead time.

## Selective Materials Plan

Selective Materials Plan (23.3) lets you plan master scheduled items separately from MRP items. If you use the computer-assisted approach to master scheduling, you may want to run Selective Materials Plan as follows.

- 1 Run Selective Materials Plan for master schedule items only.
- 2 Adjust the master schedule and rerun Selective Materials Plan as needed.

### 3 Run Selective Materials Plan for MRP-scheduled items only.

## Available-to-Promise

Available-to-promise (ATP) is the uncommitted portion of inventory or planned production available to be promised to new sales orders. The system displays ATP quantities on master schedule reports and inquiries.

ATP can be used to verify whether a sales order can be filled within a specific time frame given other demands and currently scheduled supply orders. By setting ATP Enforcement to Yes in Sales Order Control (7.1.24) and associating an ATP enforcement level with individual items, you can have the system check ATP during order entry and display a warning or error message when ATP is inadequate for the due date.

See *User Guide: QAD Sales* for information on ATP processing.

The system calculates ATP by time period by deducting real demand from real supply. Real demand includes requirements for work order components, sales orders, and required ship schedules, but excludes forecast and production forecast. Real supply includes quantity on hand, purchase orders, work orders, and repetitive schedules. A net decrease in demand increases ATP, while a net increase in demand decreases ATP.

**Note** The system regards seasonal build quantities as real demand. See page 263.

The system performs the following calculation for each date when a Master Scheduled receipt is due or a seasonal build quantity is made available, causing a net increase in supply. It takes into account all sales order and required ship schedule demand and gross requirements up to the next increase in available supply.

$$\text{Master Scheduled Receipt} - \text{Sales Orders and Required Ship Schedules} - \text{Gross Item Requirements} - \text{Seasonal Build Net Increases} + \text{Seasonal Build Net Decreases} = \text{ATP}$$

When demand exceeds supply, ATP for that period is zero. The system applies excess demand as real demand in the following order:

- Excess demand is applied against the ATP quantity for previous periods until all excess demand is eliminated or the ATP quantities for previous periods are exhausted.
- If demand exceeds supply after prior-period ATP is consumed, the system consumes future-period ATP until demand is satisfied or all supply is exhausted.
- When both past and future ATP is exhausted, the system displays a negative ATP quantity for first period.

ATP and the master schedule are bucketless because they are calculated using dates rather than fixed periods. However, master schedule report functions let you report ATP quantities in monthly, weekly, daily, or GL calendar period buckets.

See “Generating Master Schedule Reports” on page 264.

## Multilevel Master Scheduling

Sometimes, demand for one item is dependent on demand for another item. This is typical in assemble-to-order environments where it is unrealistic to stock all of the possible combinations of end items included in the selection of available models and options.

In these cases, it is impossible to accurately forecast all of these possible combinations for master production scheduling purposes. Instead, you can forecast items at the family-item and planning or option-item levels. Multilevel master scheduling enables you to perform this type of forecasting for planning purposes.

### Planning Bills

You can establish the relationship between family-level items and component items by defining planning bills in Product Structure Maintenance (13.5) or Formula Maintenance (15.5). These are identified with a structure type of P (planning).

Usually, the top-level item of a multilevel master schedule product structure, or planning bill, represents the entire group, or family, of products that can be configured from a set of available models and options. Family items are never manufactured or stocked. You must define family items with a Pur/Mfg code of Family (F) in Item Master Maintenance (1.4.1), Item Planning Maintenance (1.4.7), or Item-Site Planning Maintenance (1.4.17).

Components of the family item in the planning bill can be any type of item: manufactured, configured, or another family item.

A planning bill also contains a forecast percentage. The forecast percentage is the probability that a component of the family-level or parent item will be required, given the requirements for its parent. Components with structure code Planning consume the forecast for their parent.

**Example** The sale of a specific type of computer, entered in the planning bill with a structure code of Planning, consumes the computer family forecast, but the sale of an extended keyboard, an option, does not.

### Option Bills

Structure type O (option) also affects forecasting and master scheduling. Options are typically used with configured products to indicate one of a set of choices.

Option bills are treated in the same way as planning bills by master scheduling. The forecast percentage and quantity per for the option determines the production forecast. However, unlike components in a planning bill, independent demand can often exist for an option.

For example, a Zip drive is an option for a computer model. You enter a forecast percentage indicating how frequently a Zip drive is included when a computer is purchased. Zip drives can also be sold as a separate item.

When you sell a Zip drive separately, it does not consume production forecast. If, however, you have an independent forecast for the zip drive, not derived from upper-level requirements, it will be consumed.

If you know that an option will be sold both by itself and as part of another item, you can plan production by either increasing the forecast percentage associated with the product structure or entering independent forecast in Forecast Maintenance Production Forecasts.

## Production Forecasts

When you establish planning bills and forecast and master schedule at the family-item level, the system automatically calculates the derived demand for components of the family or upper-level item. These calculations are based on the ATP quantities for the family-level item and the quantity per and forecast percentage for the components of that family item. The result is called a *production forecast*, since it derives from the master production schedule and the forecast percentage specified in the planning bill.

Production forecasts are only created for components with structure codes P and O. Production forecast amounts display in MPS reports and inquiries and contribute to the total demand that MRP regards as input.

As forecast for the family-level item is consumed, the ATP quantity for that item changes, resulting in revised calculations for the production forecast the next time MRP is run.

**Fig. 12.10**  
Multilevel Master Scheduling Example

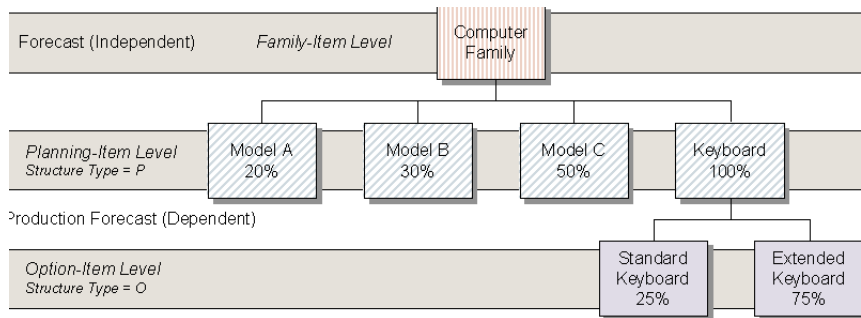

## Multilevel Scheduling Techniques

When using multilevel master scheduling, you can plan family-level items using either the fully automatic or the computer-assisted technique. Either way, you must use MRP to plan orders in order to generate production forecasts for the components of these family items.

See “Approaches to Master Scheduling” on page 257.

Set the following values for family-level items in Item Master Maintenance (1.4.1) or Item Planning Maintenance (1.4.7).

*Master Schedule.* Yes.

*Plan Orders.* Yes.

*Order Policy.* Any option other than blank.

*Time Fence.* Optional.

The components of a multilevel master schedule can be planned using either the fully manual or computer-assisted technique.

## Maintaining Master Schedule Orders

You can enter master schedule orders as firm planned work orders or create them using repetitive schedules. Under some circumstances, they are also automatically generated when you create flow scheduled orders.

### Work Orders

You can enter master schedule orders as firm planned orders using Master Schedule Order Maintenance (22.13) or Work Order Maintenance (16.1). When you set the order status to Firm Planned, MRP explodes the parent item's product structure when planning the gross requirements for its components. Master schedule orders are managed and released like normal work orders.

See Chapter 6, "Work Orders," on page 73.

### Flow Scheduled Orders

When you enter a flow scheduled order using Flow Schedule Maintenance (17.13.3) and do not include a reference to an existing work order, the system automatically creates a type W (Flow) work order for the due date and required quantity entered on the flow scheduled order. The status of the order is set to exploded, and MRP uses it when planning requirements.

See *User Guide: QAD Lean Manufacturing*.

**Note** You cannot update system-maintained type W work orders using Master Schedule Order Maintenance or Work Order Maintenance.

### Repetitive Schedules

If you use the Advanced Repetitive or Repetitive module to manage your manufacturing processes rather than the Work Orders module, you can enter your master schedule as a repetitive schedule.

See Chapter 8, "Advanced Repetitive," on page 113 and Chapter 9, "Repetitive," on page 171.

Do this using Schedule Maintenance (18.2.1 or 18.22.2.1). Then, explode the repetitive schedule to create scheduled orders by running Net Change MRP (23.1), Regenerative MRP (23.2), and Schedule Explosion (18.2.4 or 18.22.2.4). Exploding the repetitive schedule creates new scheduled orders and revises existing orders to support the repetitive schedule.

**Note** You can modify the master production schedule by modifying the repetitive schedule and then re-exploding it.

Scheduled orders are work orders with a type code of Scheduled and a status of Exploded. They have their own bills of material.

To produce the master scheduled items, you can use the programs in the Advanced Repetitive or Repetitive module or convert the scheduled orders to regular work orders, if required.

**Note** When a scheduled order is converted to a regular work order, it is no longer part of the repetitive schedule.

## Verifying Capacity for Master Schedules

You can verify master schedule orders against user-defined resources, as for product lines, using the Resource Plan module. The resource plan functions convert ordered end-item quantities into resource units to calculate resource consumption.

See *User Guide: QAD Supply Chain Planning* for more information.

You can also verify capacity for master schedule orders by department, work center, or machine using the Capacity Requirements Planning (CRP) functions.

See Chapter 14.

## Master Scheduling for Seasonality

For products with seasonal demand cycles, you may need to build up inventory in advance of periods of peak demand. You can do this using work orders or repetitive schedules, or you can use seasonal build requirements to build up inventory to a predetermined level prior to its expected demand.

Seasonal build requirements let master schedulers specify a target inventory level for seasonal demand items that is not included when calculating ATP quantities, but can still be allocated and shipped on sales orders and customer schedules. Seasonal build quantities appear separately on master schedule reports that display ATP quantities.

**Example** 600 snowmobiles are scheduled to be completed in July due to a seasonal build requirement. A rush order for 200 snowmobiles arrives from Australia for shipment in July. The current production of snowmobiles would not be promised to that order, since it would be excluded from the ATP calculation.

MRP plans for the target inventory levels set by seasonal build requirements. Specifying seasonal build requirements causes MRP to plan orders to satisfy those requirements and prevents it from issuing action messages to cancel or delay orders for seasonal build items when their demand is not yet apparent.

Use Seasonal Build Maintenance (22.9) to create seasonal build forecasts for items by site. You must define an end date by which you need items in inventory and a seasonal inventory quantity needed by that end date.

**Fig. 12.11**  
Seasonal Build Maintenance (22.9)

Seasonal Build Maintenance

Seasonal Build Maintenance: Go To Actions

Site: 10000 NJ Plant  
Item Number: 2-BB Orange Bean Bag

Date: 03/05/2007  
Reference:    
Seasonal Inventory:  UM: EA

**Example** If you need 600 snowmobiles available in inventory by December 1st, you may decide to build them during the previous three months at a rate of 200 per month. You would then enter the following values:

Date	Order Period	Seasonal Inventory Required
09/30/05	39	200
10/31/05	44	400
11/22/05	47	600
12/1/05	48	0

Setting the seasonal inventory quantity to 0 (zero) for December 1st indicates that the seasonal build requirement is complete. This means that the item is now included in ATP calculations and is considered a source of supply by MRP.

See “Available-to-Promise” on page 259.

**Note** Since MRP sums (nets) multiple seasonal build records within an order period, ensure that the seasonal build forecast for zero is in an order period (48) following the period (47) with the forecast for the final quantity of 600. If the forecasts for 600 and zero are in the same order period, MRP does not create orders for the final 200 units and only the 400 previously built are released to ATP.

## Generating Master Schedule Reports

The Master Schedule Summary Inquiry and Report (22.18 and 22.19) and Master Schedule Detail Inquiry and Report (22.21 and 22.22) functions display the following information:

*Production Forecast.* System-calculated forecast used in multilevel master scheduling. See page 259.

*Forecast.* Forecast quantity for an item, either loaded into forecast summary records using Simulation to Summarized Forecast (22.7.13) or manually entered using Forecast Maintenance (22.1) or Forecast Worksheet Maintenance (22.2).

*Sales Orders.* Demand derived from confirmed sales orders and required ship schedules. See page 255.

*Gross Requirements.* Manufacturing requirements from a parent work order. On a multilevel bill, gross requirements can include both master-scheduled family items (type P) and components of any type. In a DRP environment, gross requirements may also indicate intersite demand. See Chapter 13.

*Master Scheduled Receipts.* Total scheduled receipts for an item from work orders, repetitive schedules, purchase orders, and distribution orders.

*Projected QOH.* Projected item quantity on hand, calculated by the system. This is a projection by period of an item’s on-hand balance plus scheduled receipts minus gross requirements.

*Available-to-Promise.* The uncommitted portion of inventory or planned production, calculated by deducting real demand from real supply. See page 259.

*Cumulative ATP.* A running total based on available-to-promise quantities.

**Note** To prevent the program from consuming ATP from other periods, set Negative ATP to Yes. This allows the system to display negative ATP in any column of the report.

*Seasonal Build.* Seasonal build quantity in inventory for that period, not included in the ATP quantity. See page 263.

The Master Schedule Detail Inquiry and Report functions (22.21 and 22.22) display the same information as the Master Schedule Summary Inquiry and Report, sequenced by due date. They also include source-to-demand pegging details, allowing you to identify the actual work order or sales order generating a particular item requirement.



# Material Requirements Planning

Material Requirements Planning (MRP) is a key manufacturing planning process that uses a site's master schedule and all other sources of demand and supply to:

- Calculate gross item requirements and projected on-hand inventory
- Schedule and plan orders
- Produce action messages

The following topics explain how to create and maintain a material requirements plan.

***Introduction 268***

Introduces MRP and elaborates on MRP's functions and requirements.

***Setting Up MRP 269***

Outlines which data to set up in a system before running MRP.

***Executing MRP 276***

Details the options and available functions of MRP Processing, Scheduling, Pegged Requirements, and Planning Modes.

***Reviewing MRP Output 280***

Describes MRP's primary outputs; Action Messages and Planned Orders.

***Approving Planned Orders 283***

Details how to approve planned purchase, work, and line orders using Planned Purchase Order Approval, Planned Work Order Approval, and Planned Repetitive Schedule Approve.

## Introduction

Material requirements planning (MRP) balances supply and demand for purchased and manufactured items. Given a set of demands or requirements, MRP automatically calculates a time-phased schedule of planned supply orders or replenishments to satisfy those demands.

MRP looks at demand for finished items and uses product structure information to calculate demand for component items. For each item, MRP looks at the ordering information, the amount currently on hand, and lead times, and generates planned orders suggesting how many of that item to buy or make and when to do so.

### MRP and Sites

MRP's planning activity is performed by site. Each site's material plan is completely independent from inventory, demand, and supply at other sites. You can run MRP for several sites in succession, but it does not plan for these sites as a group.

For organizations with multiple sites, MRP can be used in conjunction with distribution requirements planning (DRP), which balances supply and demand among sites.

See *User Guide: QAD Supply Chain Planning*.

### Sources of Demand and Supply

MRP uses the master production schedule (MPS) to calculate dependent component demand. Dependent demand is directly derived from the demand for other items, and includes demand for components items, raw materials, and subassemblies.

Independent demand is demand that cannot be calculated or derived from demand for other products. It is represented through forecasts and sales orders, and includes demand for end products and replacement items. Independent demand generally passes to MRP through the master production schedule.

See Chapter 12, "Forecasting/Master Schedule Planning," for more detail.

### Sources of Demand

MRP considers the following as sources of demand:

- Forecasts
- Sales orders
- Customer scheduled orders from a required ship schedule
- Intersite orders, generated by DRP
- Component requirements from manufacturing
- Production forecasts
- Safety stock requirements

MRP does not consider unconfirmed sales orders or component requirements from batch firm-planned orders as sources of demand.

## Sources of Supply

MRP considers the following as sources of supply:

- Nettable quantity on hand (QOH)
- Purchase orders
- Intersite requests, generated by DRP
- Manufacturing orders (work orders and repetitive schedules)
- System-generated work orders resulting from flow scheduled orders
- Quality orders
- Supplier scheduled orders

MRP does not consider blanket purchase orders or non-nettable inventory as sources of supply.

## Setting Up MRP

Before running MRP, set up the following data in your system:

- Control program parameters in MRP Control
- Item planning parameters
- Inventory status codes
- Product structures and formulas

## MRP Control

Enter appropriate values in MRP Control (23.24).

**Fig. 13.1**  
MRP Control (23.24)

The screenshot shows the 'MRP Control' dialog box with the following fields and values:

MRP Horizon:	300
MRP/DRP Combined:	<input checked="" type="checkbox"/>
Summary Default:	Monday
Order Release Horizon:	60
Enable Op Based Yield:	<input checked="" type="checkbox"/>
Use AppServer:	<input type="checkbox"/>
AppServer Name:	
Default Number of Threads:	0
Max Dynamic Time Fence:	25

**MRP Planning Horizon.** Enter the period of time, in calendar days, which MRP should plan. MRP calculations ignore data outside this time period. The horizon should be at least one day longer than the longest item cumulative lead time in the database.

If you change the MRP planning horizon, impacted items are not automatically replanned when you run net change MRP. Ensure that all items are replanned by running MRP in regenerative mode.

**MRP/DRP Combined.** Enter Yes to indicate that MRP planned items can be planned using DRP functions. Enter No if they can only be planned using MRP functions. See *User Guide: QAD Supply Chain Planning*.

**Summary Default.** Specify the day of the week used by all MRP summary reports and inquiries when displaying item requirements summarized by week.

**Order Release Horizon.** Enter the number of calendar days before a planned order's release date on which the Release Due For action message should appear.

The order release horizon should be based on your normal paperwork lead time and how often you run MRP. For example, if you run MRP weekly, you should set the order release horizon to at least seven days. If you run MRP daily, you can set it to zero.

**Enable Op Based Yield.** This field determines how the system calculates yield for component items when product structures and routings are exploded in material requirements planning (MRP) programs, work orders, repetitive, advanced repetitive, and configured products. See "Operation-Based Yield" on page 30.

No: The system uses the Yield % field associated with the parent item in Item Planning Maintenance or Item-Site Planning Maintenance to calculate component requirements.

Yes: The system derives the yield percentage amount for components from operations on the parent item's routing. The Yield % field associated with the item is used for the parent item only, not the components.

Even when Enable Op Based Yield is Yes, operation-based yield is only calculated for parent items with Operation Based Yield set to Yes in either Item Planning Maintenance (1.4.1 or 1.4.7) or Item/Site Planning Maintenance (1.4.17).

Setting this field to Yes typically results in more accurate calculations and prevents overplanning of components. This is especially true in a mature process where yield percentages are highly predictable.

**Use AppServer.** Specify whether your system uses a Progress application server to enhance MRP performance. See "Improving MRP/DRP Performance" on page 278.

**AppServer Name.** When Use AppServer is Yes, enter the name of the application server that is configured to run the MRP programs. The value you enter must already be defined in AppServer Service Maintenance (36.19.1).

**Default Number of Threads.** When your system uses an AppServer for MRP processing, enter the default number of processing threads, or agents, that the AppServer can create. This can be any integer up to 99.

This value defaults to the Number of AppServer Threads field in the MRP programs. You can update it based on the overall load on your system when you run MRP.

As a general rule, set this field to twice the number of processors your computer has. For example, if you have a dual-processor machine, set the field to 4. You can adjust it based on how well your system and MRP perform.

**Max Dynamic Time Fence.** Specify the number of days that the system will use in determining a dynamically calculated time fence that controls whether MRP/DRP can replan orders.

When this value is greater than the Time Fence value specified for the item master or item-site, the system adds Max Dynamic Time Fence to the current date, and sets the time fence as the due date of the last order that falls within this period. In effect, this prevents scheduled receipts far in the future from affecting when new planned orders are created.

When this is zero (the default) or less than the value specified for the item, the system adds the item time fence to the current date and uses that as the time fence.

## Item Planning Data

MRP uses item planning data to plan items. Define this data in Item Master Maintenance (1.4.1) or Item Planning Maintenance (1.4.7). If an item is used at multiple sites, you can set up planning data differently for each site using Item-Site Planning Maintenance (1.4.17). Data not defined in Item-Site Planning Maintenance defaults from Item Master Maintenance or Item Planning Maintenance.

**Fig. 13.2**  
Item Planning Maintenance (1.4.7)

## Master Schedule

For non-master scheduled items planned by MRP, set Master Schedule to No. This lets you plan master scheduled and MRP-planned items separately, if required, using Selective Materials Plan (23.3). Items with Master Schedule set to No are excluded from reports and inquiries in the Forecasting/Master Plan (22) module.

See “Creating Master Production Schedules” on page 257.

For master scheduled items, set Master Schedule to Yes. Items subject to independent demand, such as end products or service parts, are usually master scheduled.

## Plan Orders

When Plan Orders is Yes and a value is specified in the Order Policy field, MRP generates planned purchase and work orders to satisfy net requirements for this item.

If Plan Orders is No and an order policy is specified, MRP plans this item but does not generate planned orders for it. Only action messages, suggesting orders that should be placed, are generated.

### Pur/Mfg Code

MRP uses the Pur/Mfg code to distinguish manufactured items from purchased items. A code of Manufactured, Routable, Configurable, Family, Line, Flow, or blank indicates that an item is usually manufactured, while a code of Purchased indicates that it is usually purchased.

MRP generates planned work or line orders for manufactured items and planned purchase orders for purchased items. However, you can create and approve planned work or line orders for purchased items or planned purchase orders for manufactured items. This field indicates only what the normal procedure is, not what it must be.

### Run Sequences

Run sequences are used when MRP planned orders are approved for line manufacture using Planned Repetitive Schedule Approve (23.8).

If multiple items are produced on a single production line, efficiency can be improved by producing the items in a certain order. Run sequences let you control the order, or sequence, in which items are scheduled on a production line.

An item's run sequences are sorted by primary run sequence and then secondary run sequence. A two-digit numeric value should be the first characters of a run sequence. This convention provides enhanced control over the sorting of run sequences.

**Example** Items 100, 200, and 300 are produced on production line 500. These items are made of plastic and have different colors: items 100 and 200 are green, item 300 is white. To minimize the change-over time between items, they must be scheduled in the following sequence:

- Items 200 and 300 produced before item 100
- Item 300 produced before item 200

To make sure approved orders with the same due date for items 200 and 300 are scheduled before orders for item 100, enter 01Plastic as the primary run sequence for items 200 and 300 and 02Plastic for item 100. To schedule approved orders for item 300 before orders for item 200, enter 01White as the secondary run sequence for item 300 and 02Green for item 200.

When approving planned orders for these items with Planned Repetitive Schedule Approve (23.8), set Sort by Run Sequence to Yes. Table 13.1 illustrates the resulting production schedule for line 500.

**Table 13.1**  
Production Line Sequence Using Run Sequences

Production Sequence	Item Number	Primary Run Sequence	Secondary Run Sequence
1	300	01Plastic	01White
2	200	01Plastic	02Green
3	100	02Plastic	02Green

## Order Policy

The order policy determines the number and size of each MRP planned order. If an item's Order Policy is blank, it is ignored by MRP, and planned orders or action messages are not generated for it. Any value entered in the Order Policy field other than those listed in Table 13.2 is processed by MRP as lot-for-lot.

Leave Order Policy blank for items planned manually based on a reorder point.

**Table 13.2**  
Order Policy

Order Policy	Description
Period order quantity (POQ)	MRP calculates demand for this item over the number of calendar days specified as the Order Period and creates one order to satisfy this demand.
Fixed order quantity (FOQ)	MRP generates planned orders for the quantity specified as the Order Quantity. If the quantity required exceeds this quantity, multiple orders are generated.  If the quantity in the Min Ord field is greater than the specified order quantity, planned orders are generated for this minimum quantity.
Lot-for-lot (LFL)	MRP generates a separate planned order to satisfy each net requirement. If there are many sources of demand, MRP creates many planned orders.  When LFL policies are used across multiple product levels, running MRP may produce unmanageable numbers of manufacturing orders.
One time only (OTO)	MRP generates a single planned order with a quantity of one unit. As long as one order for this item exists, the system will not create another. OTO can be used for prototype items, or for planning project activities and one-time events.

## Order Modifiers

MRP uses order modifiers along with order policies to determine planned order quantities.

**Table 13.3**  
Order Modifiers

Order Modifier	Description
Order Quantity	The quantity for which all MRP planned orders are created for an item with an order policy of FOQ.
Safety Stock	The quantity of this item maintained in inventory as protection against fluctuations in demand or supply. MRP processing considers safety stock a requirement, and schedules planned orders to cover this requirement.  You should not designate safety stock levels for non-master scheduled items because it may cause MRP to overplan inventory.
Minimum Order Quantity	The minimum quantity allowed for a planned order. If the net requirement is below this amount, MRP creates an order for this minimum quantity. To ensure that items that have decimal demand values due to yield or scrap calculations are ordered in whole number quantities, set this value to 1, or to any whole number.

Order Modifier	Description
Maximum Order Quantity	When a net requirement exceeds this amount, MRP generates the action message <code>Order Exceeds Maximum</code> for the order created to fill this requirement.
Order Multiple	When order policy is POQ or LFL, planned orders are created in multiples of this quantity. For example, if the order multiple is 100, planned orders are only created for quantities of 100, 200, 300, and so on.
Yield %	<p>The percentage of an order expected to be in usable condition. If Yield % is less than 100%, MRP plans orders for more than needed. For example, if the net requirement is 100 and the item Yield % is 50%, then the planned order quantity will be 200.</p> <p>You can enter this value manually or use Routing Cost Roll-Up (14.13.13) to calculate yield percent based on the yield percentages at each operation in the item routing.</p> <ul style="list-style-type: none"> <li>• If operation-based yield is No, MRP uses this yield percentage amount to calculate component requirements.</li> <li>• If operation-based yield is Yes, the yield percentage for components is derived from the parent item's routing data. The item yield percentage is ignored.</li> </ul> <p>If an item's yield percentage is less than 100 percent, MRP may generate planned orders for fractional quantities. To prevent this, set Order Minimum or Order Multiple to 1, or any whole number.</p>
Scrap %	<p>The percentage of a component item expected to be scrapped during manufacture of the parent item. This value increases the component requirements for planned orders for that component-parent pair. Specify scrap % values for components in Product Structure Maintenance (13.5).</p> <p>When scrap percentage is greater than zero, MRP may calculate fractional component quantities, even if the component is a discrete item.</p> <p>For example, if one housing is required to build an item and the scrap factor is 5%, the system will calculate a requirement for 105.2631 housings to make 100 units. To prevent MRP from generating planned orders for fractional quantities, set Order Minimum or Order Multiple to 1, or any whole number.</p>

## Lead Times

Lead time determines when MRP planned orders are due—manufacturing lead time for manufactured items, and purchasing lead time plus inspection lead time for purchased items.

For both purchased and manufactured items, if the lead time varies, you can define a safety time. MRP then calculates the planned order due date by adding safety time to the lead time.

**Table 13.4**  
Lead Times

Lead Time	Description
Manufacturing Lead Time	The number of working days it takes to manufacture an item, including the time it takes to process paperwork, issue components, inspect the finished product, and receive it into stock.  For DRP items, enter DRP transit and order time in this field so that this value is included in the cumulative lead time for this item.
Purchasing Lead Time	The number of calendar days it takes to complete a purchasing cycle for an item, from the date the need for a purchase is recognized to the date the item is received.
Inspection Lead Time	The number of working days it takes to inspect a purchased item after it is received.
Safety Lead Time	The number of working days early that MRP plans to receive orders for an item, to allow for late deliveries.
Cumulative Lead Time	The longest number of calendar days it takes to obtain an item, assuming that neither it nor any of its components are in stock. The system calculates this value, by converting manufacturing, inspection, and safety lead time to calendar days.

### Time Fence

The time fence is the number of calendar days inside of which MRP will not generate or adjust any planned orders, even if there are net requirements within that period. MRP still deletes a planned order, even if it is inside the time fence, if no demand is generated for that item.

Time fences are often used with master scheduled items and are usually set to greater than or equal to the manufacturing lead time.

**Note** Based on the value of Max Dynamic Time Fence in MRP Control, the system may not use the Time Fence specified for the item. See “Max Dynamic Time Fence” on page 270.

### MRP Required

The MRP Required field is set by the system to indicate whether this item has had changes made against it and will be replanned the next time you run net change MRP. Yes indicates that the item will be replanned; No indicates that it will not.

See “Net Change Materials Plan” on page 279.

### Inventory Status Codes

Assign a non-nettable inventory status code to inventories that should not be considered quantity on hand by MRP. This might include inventory to be returned to a supplier or designated as scrap or salvage.

## Product Structures and Formulas

Product structures and formulas provide some of the information used in MRP calculations, including component quantities, lead times, and effective dates. Enter and modify product structure and formula information in Product Structure Maintenance (13.5) and Formula Maintenance (15.5).

See Chapter 2 and Chapter 4 for details.

### Component Quantity

To calculate component requirements for planned orders, MRP multiplies each component's quantity per assembly value by the planned order release quantity.

### Component Lead Time

MRP determines a component's due or required date using the scheduled release date of the parent item and the component lead time offset specified in the product structure.

**Example** When a component's lead time offset is 10 days, its due date will be 10 manufacturing days after the planned release date of the assembly. When it is -5 days, the due date is 5 manufacturing days before the planned release date of the assembly.

If no lead time offset is specified for a component, the component release date will be the same as the release date for the parent item.

### Component Effective Dates

MRP uses component effective dates to determine which components are required for a given order due date. Components are active beginning on the start date specified in the product structure and remain active through the stop date, the last day a component will be used.

See "Engineering Effectivity" on page 15 for more information on how MRP handles component effective dates.

## Executing MRP

### MRP Processing

MRP reports and inquiries can optionally display item requirements summarized by week. The beginning day of the week is specified in the Summary Default field of MRP Control. Calculations are based on this weekly period.

MRP calculates net requirements for items using three variables:

- Gross item requirements are the sum of an item's requirements from forecasts, higher level products, customer orders, service items, and intersite orders. They do not take into account inventory on hand or scheduled receipts.
- Scheduled receipts for that item, including open purchase orders, open work orders with a quantity open and a status of R, and intersite requests for DRP items.

- Quantity on hand from the previous period.

MRP uses these three variables in the following calculation:

$$\text{Net Requirements} = \text{Gross Requirements} - \text{Quantity on Hand for the previous period} - \text{Scheduled Receipts}$$

MRP schedules planned purchase orders and work orders to fill these net requirements. Planned work orders generated by MRP are exploded into gross requirements for their components. This process continues until there are no more planned work orders to explode.

**Note** MRP does not explode product structures for purchased and distribution items or components with structure code Document.

### Yield Calculations

When MRP plans orders for a parent item, it also determines if orders are required for any of the parent's component items.

MRP generates component requirements using the standard product structure or formula effective for that item-site or site on the date of the requirement. Alternate structures and substitute items are not considered by planning.

Yield is also considered by MRP when it calculates component requirements. These calculations are based either on the parent item yield percentage or the yield associated with each operation in the parent's routing. Operation-based yield is used when both of the following are true:

- Enable Op Based Yield is Yes in MRP Control.
- Op Based Yield is Yes for the parent item in Item Master Maintenance or Item-Site Planning Maintenance.

If the parent item qualifies for operation-based yield calculation, each component could potentially have a different yield percentage.

See "Yield" on page 29.

If a component item is a global phantom, MRP may need to blow through the phantom and plan another order for any required components of the phantom.

The system automatically applies the yield percentage of a global phantom to each of its components. This is true even if the parent item's planned order includes components of local phantoms.

See "Phantoms" on page 8 for more information on global phantoms.

### Co-products and Base Processes

MRP plans co-products and base processes differently than other items. Net requirements for co-products are passed down to their respective base process items. MRP then generates planned orders for base process items to meet these requirements. These planned orders are imploded, creating planned orders for each of the co-products and by-products.

See Chapter 5, "Co-products and By-products," for more details.

## Routable Assemblies

For routable assemblies, MRP generates a separate routable work order when an order for the parent item is released. Usually, you should not approve these orders or change their status to firm planned.

## Improving MRP/DRP Performance

Because of the number of calculations required in an MRP or DRP run, it can be a time-consuming, resource-intensive process. MRP/DRP is typically executed as a batch process; for example, at night, when the load on the system is usually much lower.

To enhance MRP/DRP performance in an environment that includes Symmetric Multiple Processor (SMP) computers, your system can be configured in two optional ways, which are described in more detail in the DRP discussion:

- Running synchronized, simultaneous MRP/DRP calculations by defining synchronization codes. See the DRP chapter in *User Guide: QAD Supply Chain Planning* for information.
- Using a Progress application server (AppServer) to perform multi-threaded processing, which allows MRP/DRP tasks to be spread out among more computing resources. See *User Guide: QAD System Administration* for information on AppServers.

These methods can result in a significant improvement in the time required to run MRP—particularly with scenarios such as running regenerative MRP for a large database that includes multiple sites.

## MRP Scheduling

When MRP runs, it compares each item's demand with existing supply orders for each period. It automatically reschedules planned orders to reflect changes in the plan and generates an action message for each rescheduled order. Some orders MRP cannot change because they are firm planned or within the time fence specified in the item planning data. For these, it generates action messages suggesting that these orders be rescheduled to balance supply with demand.

When MRP reschedules planned orders for higher-level end items, lower-level components dependent on the rescheduled demand remain associated with the original supply order date. They are not automatically rescheduled based on where action messages say parent orders should be moved. To adjust for this:

- 1 Run selective MRP for master scheduled items and review and handle action messages.
- 2 Run selective MRP again at this level to ensure that all action messages have been dealt with.
- 3 Then, run regenerative or net change MRP for all dependent demand items.

## MRP Pegged Requirements

MRP source-to-requirement pegging makes it possible to review each of the sources of demand for gross requirements. Use MRP Detail Inquiry (23.16) or MRP Detail Report (23.17) to:

- Trace the requirement for a particular end item to the forecast or sales order creating the demand.

- Identify the specific parent item creating the need for a component item.

Pegging is made possible by low-level codes, which maintain a numeric value for each item relative to its parent item, including items planned across sites using DRP.

The lowest-level components of product structures in the database are assigned low-level codes of 0 (zero). Items at the next level are assigned a low-level code of -1, and so on.

**Example** At a particular site, a purchased component has a low-level code of 0. That component is then built into an assembly, which is assigned a low-level code of -1. The assembly item is built into an end item that is assigned a low-level code of -2. The end item is then packaged and assigned a low-level code of -3.

When MRP is run across multiple sites in the same database, it processes lower-level items first, regardless of site. Purchase orders and intersite requests are generated after all site and intersite demand has been calculated.

Because item planning, product structure, MRP, and DRP transactions can alter low-level codes, net change and regenerative MRP automatically update low-level codes before performing calculations. Selective MRP updates low-level codes only if you set Resolve Low Level Codes to Yes. You can also use Low Level Code Update (23.22) to resolve codes as a separate

MRP Detail Inquiry (23.16) and MRP Detail Report (23.17) display each source of demand for an item with the due date, item quantity, parent item number, and type of requirement—whether forecast, production forecast, sales order, customer schedule, work order, or repetitive.

**Note** Run MRP reports and inquiries immediately after MRP, since they are sensitive to changes in inventory, demand, and supply.

## MRP Planning Modes

MRP can be run in three operational modes:

- Regenerative MRP plans for all items at selected sites.
- Net change MRP plans only for items that have changed since MRP was last run. It produces the same results as regenerative MRP, but generally requires less time to execute.
- Selective MRP plans only for the items you select.

## Net Change Materials Plan

Net Change Materials Plan (23.1) considers only items with MRP Required set to Yes in their item planning data. The system sets this field to Yes automatically when changes occur for an item in any of the following areas:

- Item or item-site planning data
- Product structures
- Sales or purchase orders
- Work orders or repetitive schedules
- Inventory
- Forecasts
- Master production schedule

- Intersite demand

In addition to planning items that have changed, net change MRP recalculates lower-level requirements for items planned. Typically, Net Change MRP is run daily.

Both net change and regenerative MRP plan items based on low-level codes. They determine requirements at the top level first, then continue down through the item structure, one level at a time.

### Regenerative MRP

Regenerate Materials Plan (23.2) recalculates demand and plans supply for all items in the site. The outputs of net change and regenerative MRP are the same. However, net change MRP generally runs faster than regenerative, since it only plans for items that changed since MRP was last run.

You should always schedule periodic regenerative MRP runs, even if you primarily use net change MRP, since net change MRP does not consider demand or forecast for items entering the MRP horizon over time.

**Note** The first time you run MRP, it should be regenerative.

### Selective Materials Plan

Selective Materials Plan (23.3) plans only for items and sites you select. It can be run in net change mode by setting the Required Items Only field to Yes, or in regenerative mode by setting Required Items Only to No.

You can use Selective Materials Plan to plan master schedule items separately from other items, or to plan small groups of items by using buyer/planner, product line, group, type, supplier, or any combination of these, as selection criteria.

Set MRP Items to Yes to generate planned orders for items at the specified sites and gross requirements for DRP items. Set DRP items to Yes to generate intersite requests for DRP items.

Selective MRP recalculates demand and plans supply only for selected items, passing down gross requirements to the next non-selected level, but not replanning orders. It does not implode product structures to replan higher-level items before planning selected items, nor does it explode resulting orders to calculate component demand.

See *User Guide: QAD Supply Chain Planning*.

## Reviewing MRP Output

The primary outputs of MRP are planned orders and action messages. These are generated if MRP sees an imbalance of supply and demand.

- If supply exceeds demand, MRP automatically reschedules or cancels planned orders and generates messages suggesting you de-expedite or cancel open orders.
- If demand exceeds supply, MRP reschedules or creates planned orders and generates messages suggesting you expedite or create orders.

## Action Messages

MRP generates action messages for all items with non-blank order policies. Action messages recommend the actions a planner should take to balance supply with demand, such as rescheduling, canceling, or releasing orders.

Review action messages using Action Message Review/Update (23.5). Or use Action Message Report (23.7) to review messages by item, site, buyer/planner, Pur/Mfg code, or action message number.

Table 13.5 lists the messages generated by MRP with a brief explanation. In the explanation, a *supply order* can be a work order, purchase order, repetitive schedule, or intersite request.

**Table 13.5**  
MRP Action Messages

Message	Meaning
Beginning Quantity Less Than Zero	The initial nettable quantity on hand is negative.
Beginning Available Less Than Zero	The quantity on hand less safety stock is negative.
Create	A supply order should be created to satisfy a negative projected on-hand balance. This message is only generated if Plan Orders is No or if a new requirement appears within the time fence.
De-Expedite	A scheduled supply order is due before it is needed and should be delayed, or demand rescheduled to an earlier date.
Expedite	A scheduled supply order is due after it is needed and should be rescheduled to an earlier date, or demand rescheduled to a later date.
Cancel	A scheduled supply order is no longer needed and should be deleted.
Release Due For	A supply order should be released. You can release both planned and firm-planned orders. Approving the order changes its status to firm planned.  Use the Order Release Horizon field in MRP Control (23.24) to specify the number of days prior to the order release date for this action message to display.
Release Past Due For	A supply order was not released when it was due. It now needs to be released and expedited, or the demand must be rescheduled for a later date.
Quantity Less than Minimum	A supply order was created for a quantity less than the minimum quantity set in the item planning data.
Quantity Exceeds Maximum	A supply order was created for a quantity greater than the maximum quantity set in the item planning data.
Past Due	Scheduled supply order receipt is past the due date.
Time Fence Conflict	Unsatisfied material requirement exists inside the planning time fence for the item. MRP will not create planned orders within the time fence. You should either manually schedule and expedite orders to fill this demand or delay fulfillment of the requirement that created the demand.

Message	Meaning
Shipment Due	A shipment for an intersite request item is due. Action should be taken at the source site to ensure that the order is received on time.
Shipment Past Due	A shipment for an intersite request item is past due. You should either delay the orders that created the requirement for the item or expedite them when the item does arrive.
No Source Of Supply	A valid source network is not available for the date a DRP item is required. Either the item or item-site planning data does not reference a source network, or the source network is not effective on that date.
Planned Order Count Exceeds Maximum	An item/site combination generated the maximum number of planned orders. MRP currently cuts off the creation of orders for an item/site combination at 1000. Calculation for other items continues. This prevents runaway calculations caused by, for example, an incorrect item order quantity.

## Planned Orders

MRP generates planned orders to satisfy net requirements for items with Plan Orders set to Yes and non-blank order policies specified in the item planning data. MRP generates planned work orders for manufactured items, planned line orders for items manufactured on production lines, and planned purchase orders for purchased items based on the item Pur/Mfg code.

See “Pur/Mfg Code” on page 272.

The scheduled release date for a planned order is the item due date minus the purchasing or manufacturing lead time. For manufactured items, MRP calculates planned order release dates using the manufacturing lead time. For planned purchase orders, both the inspection lead time and the purchasing lead time are used. If a planned order release date falls on a non-workday, MRP schedules it for the last prior workday.

See “Lead Times” on page 274.

When MRP plans orders, it uses the default shop calendar for the site. If there is no shop calendar, MRP does not plan orders for that site.

Planned purchase, work, and line orders are stored with status Planned. Work orders and line orders are created with work order bills; purchase orders are not. A planned order, regardless of its type, can be approved using any of the planned order approval programs.

If you do not plan to act on a planned order, you should delete it, particularly if MRP will not be run soon. The system assumes you will take action on planned orders. Master schedule inquiries and reports include master scheduled order quantities, which are assumed to be supply and, therefore, included in available to promise. MRP inquiries and reports show all planned orders; these are not seen as supply.

## Approving Planned Orders

To approve planned purchase, work, and line orders, use Planned Purchase Order Approval (23.11), Planned Work Order Approval (23.10), or Planned Repetitive Schedule Approve (23.8). Once approved, planned orders become either purchase requisitions, firm-planned work orders, or are added to production line schedules.

After a planned order is approved, MRP does not change the quantity or due date on the order the next time it is run. Instead, it generates action messages suggesting changes to the order. You can modify firm-planned order due dates and quantities as needed in Work Order Maintenance (16.1), Purchase Requisition Maintenance (5.1.4), and Line Schedule Workbench (18.1.10 or 18.22.1.10).

### Approving Planned Purchase Orders

Approving a planned purchase order deletes the planned order and creates a purchase requisition, which can be filled by a purchase order.

### Approving Planned Work Orders

Approving a planned work order changes its status to firm planned. MRP does not replan firm-planned orders, but generates action messages as needed. A firm-planned order has a work order bill and a routing with scheduled operations. These are not fixed. Bills are re-exploded by MRP, while routings are re-exploded by CRP. Both are re-exploded when the status is changed to Exploded, Allocated, or Released.

See “Creating Work Orders” on page 78.

### Approving Planned Line Orders

Approving a planned line order adds the order amount to the schedule for that item’s production line. Orders approved for line production using Planned Repetitive Schedule Approve (23.8) are added to a schedule in a sequence according to the following hierarchy:

- Due date
- Primary run sequence
- Secondary run sequence
- Item number

The Sort Schedule by Run Sequence field controls the sequence in which orders are scheduled on a production line.

Yes: Items are sorted and sequenced by due date, primary run sequence, secondary run sequence, and item number.

No: Items are sorted and sequenced by due date and item number.

See “Run Sequences” on page 272.

The production schedule sequence for a given line can be viewed and modified using Line Schedule Workbench. Once a production line’s schedule is established, run Repetitive Schedule Update (18.1.18 or 18.22.1.18) to convert the line schedule to a repetitive schedule and remove the planned line orders from MRP.

See “Simulating Schedules in the Workbench” on page 126.

# Capacity Requirements Planning

The Capacity Requirements Planning (CRP) module uses MRP planned orders, other work orders, and repetitive schedules to determine work center load and generate a capacity requirements plan for a department, work center, or machine.

The following topics explain how to generate and maintain a capacity requirements plan.

***Introduction to CRP* 286**

Explains the functions of CRP and how they are performed.

***Defining Capacities* 286**

Defines capacities by department and work center.

***Executing CRP* 286**

Outlines when and why to run CRP.

***Generating Load Reports* 288**

Explains how to generate reports for department, work center, or machine, as well as how to review input and output.

***Adjusting Capacity and Load* 289**

Explains how to adjust timing and amount of load.

## Introduction to CRP

CRP calculates workload for a department, work center, or machine. It does this by exploding the routings and processes for MRP planned and firm planned orders and determining start and due dates for each operation, using the work center and shop calendars and a technique called back scheduling.

## Defining Capacities

The resources used to process orders on the shop floor are work centers, departments, and machines. The capacity of a department or work center is the time available for production in that location.

The capacity of a department is the total number of available labor hours per day for all work centers in that department, defined in Department Maintenance (14.1).

See “Departments” on page 19 for details.

The capacity for a work center is the number of machines or personnel available for that work center, defined in Work Center Maintenance (14.5), multiplied by work hours, defined in the shop floor calendar. You can define and maintain shop floor calendars using Calendar Maintenance (36.2.5).

See *User Guide: QAD System Administration* for more information about shop calendars.

## Executing CRP

Generate capacity requirements for manufacturing orders using Recalculate Capacity Plan (24.1).

**Note** Generally, you should run CRP after running MRP.

**Fig. 14.1**  
Recalculate Capacity Plan (24.1)

CRP determines capacities based on the available hours or machines for a work center or department. It multiplies working days, defined in the shop calendar, by work center machine capacity to calculate capacity per CRP reporting period.

CRP explodes the routings and processes for the orders you select. It then determines capacity requirements for selected manufacturing orders by scheduling their operations. CRP determines operation start and due dates using the work center and shop calendars and a technique called back scheduling.

## Back Scheduling

When CRP back-schedules orders, it takes the due date of an order or repetitive schedule and schedules each of its operations from the last operation in the order routing or process backward to the first one.

CRP assigns each operation a start date and a due date, using the operation lead time components—queue, setup, run, wait, and move—to calculate operation start dates. The start date of an operation is the same as the due date of the previous operation.

**Note** CRP calculates run times based on the actual order quantity—that is, the order quantity less the quantity completed.

When manufacturing order operations overlap, the system smoothes the scheduled start and due dates to prevent the scheduled due date for one operation from occurring later than the due date for a subsequent operation.

## Schedule Discrepancies

MRP calculates manufacturing order release dates using a manufacturing lead time that is based on an average order quantity defined in Item Planning Maintenance (1.4.7) or Item-Site Planning Maintenance (1.4.17). If the order quantities used in CRP calculations differ from this average quantity, CRP may schedule the start date for an order's first operation before the release date for that order.

When this occurs, a message displays to alert you of the conflict. You can resolve such conflicts by adjusting the order release or due date and rerunning CRP.

See Chapter 13, “Material Requirements Planning,” on page 267.

**Note** Exceptions to the normal work week in the work center and shop calendars—for example, planned overtime—may also cause schedule discrepancies in CRP.

## CRP and Order Statuses

CRP is normally executed for Planned and Firm Planned orders. For these orders, CRP explodes the standard item routing and schedules the operations to create work center/machine load.

You can also choose to include orders with other statuses. For Exploded and Allocated orders, the work order routing is scheduled. For Released orders, only open operations are rescheduled.

**Note** Repetitive schedules are treated like Exploded orders.

When you run CRP, all open operations for selected work orders are rescheduled. That means that if you have manually adjusted your operation start and stop dates, they will probably be changed unless you also adjusted the work order release and due date to match.

## Generating Load Reports

You can generate load reports by department, work center, or machine using the work center and department load inquiries and reports.

CRP determines load hours for a work center based on setup and run times. Queue, wait, and move times are excluded from load calculations. To include queue times in load calculations, set up separate operations for queue. CRP then considers these operations when calculating load.

CRP determines the load an operation exerts on a work center using the following calculation:

$$\text{Operation Load} = \text{Setup Time} + (\text{Run Hours/Unit} \times \text{Quantity Open})$$

The quantity open for an operation is the order quantity minus any quantities reported complete.

**Note** The system assigns the entire load for an operation to its scheduled start date. Even for operations with run times longer than one day, load is not spread between operation start and due dates.

## Reviewing Input and Output

You can compare the planned input and output for a work center or machine with actual input and output using Input/Output Inquiry (24.4) and Input/Output Report (24.5). These functions help you evaluate a work center or machine's response to planned loads.

**Note** Input/Output Report is also available in enhanced report format (24.29). That version can only be used in .NET UI.

You can display planned and actual input and output in daily, weekly, or monthly periods.

*Planned Input.* Planned input is load on a work center or machine represented by work order operations scheduled to start in a reporting period. It is determined using the following calculation:

$$\text{Standard Setup} + (\text{Standard Run} * \text{Quantity Ordered})$$

*Actual Input.* Actual input is load that has been moved to the first and subsequent order operations. It is calculated for a reporting period based on move transactions entered using work order release and shop floor control functions. Actual input is determined using the following calculation:

$$\text{Standard Run Hours} * \text{Quantity Moved}$$

*Planned Output.* Planned output is load calculated based on order operations scheduled to be completed in a reporting period. It is determined using the following calculation:

$$\text{Standard Setup} + (\text{Standard Run} * \text{Quantity Ordered})$$

*Actual Output.* Actual output is load calculated for a reporting period based on operation quantity completed transactions for work orders and repetitive schedules. You can report completed quantities for order operations using labor feedback transactions in the Shop Floor Control, Advanced Repetitive, and Repetitive modules, or using Work Order Accounting Close (16.21).

Actual output is determined using the following calculation:

$$\text{Actual Setup} + (\text{Standard Run} * \text{Quantity Completed})$$

**Planned Queue.** The planned queue is the difference between planned input and planned output.

**Actual Queue.** The actual queue is the difference between actual input and actual output.

**Fig. 14.2**  
Enhanced Input/Output Report, .NET UI only (24.29)

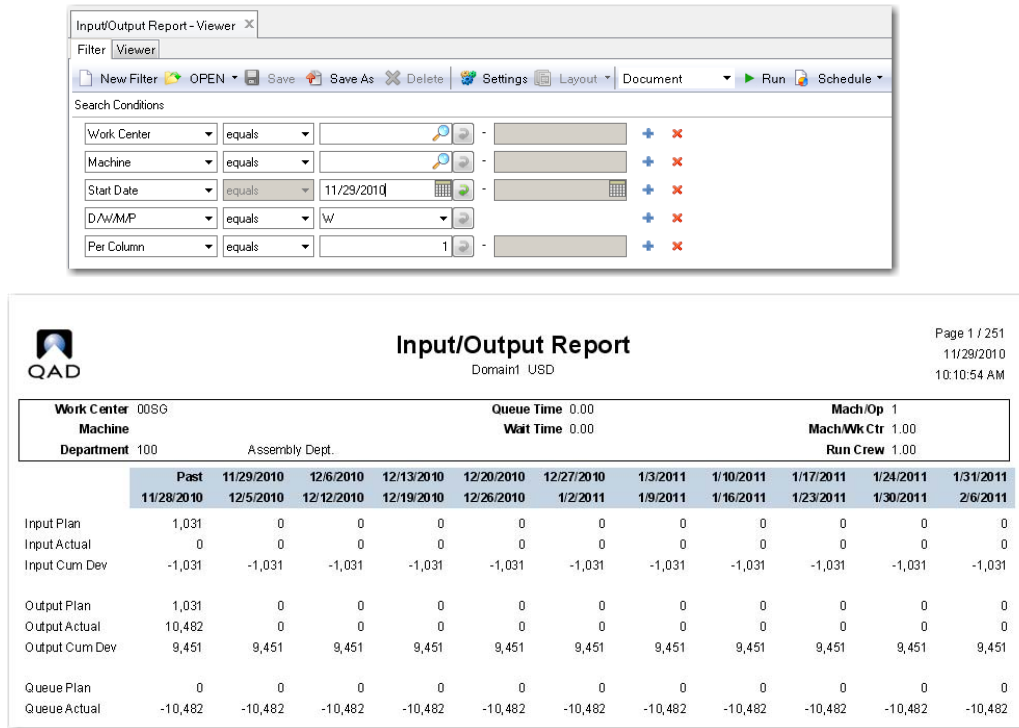

## Adjusting Capacity and Load

If a work center or machine is over- or under-loaded, you can modify either its capacity or the timing or amount of the load.

### Adjusting Capacity

Adjust capacity using one of the following functions:

- Holiday Maintenance (36.2.1)
- Calendar Maintenance (36.2.5)

Add or subtract workday hours as needed for work center or shop calendars.

### Adjusting Load

Adjust the timing or amount of load by modifying:

- Work order due dates
- Operation lead time components
- Repetitive schedules

**Note** If you manually adjust operation start or stop dates, CRP reschedules them the next time it is run.

# Reports, Browsers, and Inquiries for .NET UI

This chapter discusses enhanced functionality that is available to QAD .NET UI users of reports, browsers, and inquiries in the manufacturing modules.

***Introduction*** 292

Introduces the concept of enhanced reports and describes how to access them.

***Using Enhanced Reports*** 292

Summarizes the steps required to set up filters and select the output medium for reports.

***List of Modified Reports, Browsers, and Inquiries*** 294

Includes a cross-reference between standard programs and their equivalent enhanced versions.

## Introduction

QAD has rewritten numerous reports throughout the manufacturing modules to take advantage of the enhanced functionality available through Reporting Framework. These reports provide a significantly improved reporting capability to users of the QAD .NET UI.

For information on the tools used to write the enhanced reports, see *User Guide: QAD Reporting Framework*.

In some cases, reports have been redesigned as browses (or browses/inquiries as reports), as shown in Table 15.1.

**Note** The standard versions of the programs are still available in their original menu locations. You can use them in both character UI and .NET UI.

You can access the new programs in several ways:

- By entering the title in the menu search field. For reports, the search result lists two occurrences. Menu icons differentiate the enhanced reports from the standard versions.

**Fig. 15.1** Report Icons in .NET UI

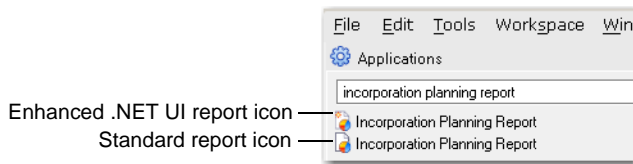

- By entering the enhanced report menu number in the menu search field (Table 15.1). The menu positions are always 25 or greater, so the .NET UI-only reports do not display on the character UI menus.

**Note** You cannot access a new report by entering a Progress program name.

- By navigating in the menu tree to the related functionality area. The enhanced reports are in the same directories as their standard report counterparts.

## Using Enhanced Reports

This topic includes a brief overview of the basic steps used to generate a report. For more information on filters, output options, and so on, see *User Guide: QAD Reporting Framework*.

## Running a Report

- 1 Access the report. The Report Filter screen is displayed in the application area.

**Fig. 15.2**  
Report Filter

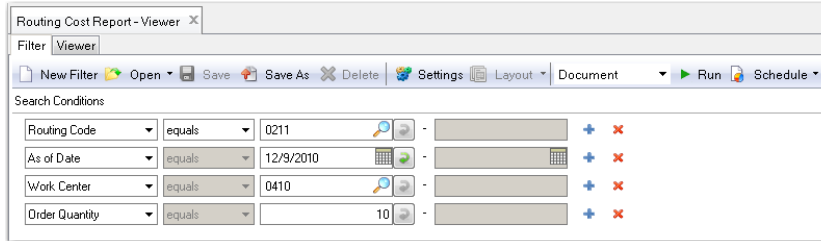

- 2 By default, a report displays all the records available in the source data. However, you may want to retrieve just a certain range of records in the report; for example, routing costs for an item at one specific work center. You do this by setting search conditions to filter data in the report for one or more of the available criteria.
  - a Configurable filter capabilities let you create both simple and complex queries. Choose a search operator from the drop-down list: equals, not equals, and so on.
  - b If you choose the Range operator, enter a beginning value of the range in the first search box. Optionally, enter an ending value of the range in the second search box.
  - c To refine your search further, click the plus (+) icon to add another search row. You can add as many rows as needed, each with different search values and operators. When you specify several criteria, note that multiple criteria for the same field are treated as a logical AND condition.
  - d To remove a search criteria row, click on the delete (X) icon.
  - e Optionally, click Save As to save the new search conditions as a filter for future reuse.
- 3 On the toolbar, select a layout from the Layout pull-down list. (This feature is available only for a report resource with multiple report definitions.) The default layout is listed in bold text.
- 4 On the toolbar, select an output format from the pull-down list before the Run button. You can choose from several output formats when the report is run:
  - Document — The report is displayed in the Report Viewer window.
  - PDF — The report is rendered as a PDF file. You can save the file and open it in the Report Viewer window.
  - PDF Read-only — The report is rendered as a read-only PDF file. It has a random password that prevents tampering with the document.
  - TIFF — The report is rendered as a Tagged Image File Format (TIFF) file.
  - RTF — The report is rendered as a Rich Text Format (RTF) file. You can open this file in Microsoft Word and save it in .doc format.
  - Excel — The report is rendered as a Microsoft Excel (.xls) file. You can save the file and open it in the Report Viewer window.
  - Plain Text — The report is rendered as a plain text (.txt) file.

- 5 On the toolbar, click Run. A report generation progress bar appears. When report generation is complete, the report is displayed in the Report Viewer window directly or opened as a PDF or Excel file depending on which output format you selected. For some formats, you can click Save to create a file of the specified type in a directory on your file system.

## Running Reports Directly From Browsers

You can directly run reports from browsers by selecting Report from the Action menu in the browse screen. The sorting, grouping, and search criteria in the browse are all carried over to the report, which uses the browse as its data source. You can further filter data in the report by defining new search criteria in the Filter screen. Just as in reports, click the plus (+) icon to add search rows.

## List of Modified Reports, Browsers, and Inquiries

**Table 15.1**  
Reporting Updates for Manufacturing Functions

Standard Menu Number	Standard Program Title	Standard Program	Enhanced Menu Number	Enhanced Program Title
3.22.13.17	WIP Lot Inquiry	wliq01.p	3.22.13.22	WIP Lot Browse
13.3	Product Structure Code Report	bmmarp.p	13.27	Product Structure Code Report
13.8.18	Simulated Picklist Report	bmpkrp.p	13.8.42	Simulated Picklist Report
13.8.20	Materials Summary Report	bmpsrp06.p	13.8.44	Materials Summary Report
14.3	Department Report	rwdprp.p	14.2	Department Browse
14.7	Work Center Report	rwwcrp.p	14.6	Work Center Browse
14.13.14	Routing Cost Report	rwrorp01.p	14.13.38	Routing Cost Report
14.17.3	Work Center/Routing Stds Report	rwwrrp.p	14.17.2	Work Center/Routing Stds Browse
15.3	Formula Code Report	fmmarp.p	15.27	Formula Code Report
15.7.1	Formula by Component Report	fmpsrp.p	15.7.25	Formula by Component Report
15.7.18	Simulated Batch Ingredient Reprt	fmpkrp.p	15.7.42	Simulated Batch Ingredient Rpt
16.20.13.9	Operation Transaction Detail Inq	sfopiq12.p	16.20.13.33	Operation Transaction Detail Report
16.20.13.12	Input/Output Report	sfiorp.p	16.20.13.36	Input/Output Report
18.1.23	Shift Report	rescrp.p	18.1.47	Shift Report
18.4.2	Repetitive Trans Detail Inquiry	reopiq12.p	18.4.26	Repetitive Trans Detail Report
18.22.1.23	Shift Report	rescrp.p	18.22.1.47	Shift Report
24.5	Input/Output Report	sfiorp.p	24.29	Input/Output Report

# Index

## Numerics

1.1.13 44  
1.2.1 44  
1.4.1 44, 51, 130  
1.4.9 51  
1.4.17 44, 130  
1.4.18 51  
1.13 48  
1.22.4 64  
1.22.24 49, 63  
1.4.1 149  
3.22.3 64  
3.22.4 64  
3.22.13.1 202  
3.22.13.13 223, 225  
3.22.13.14 204, 225  
3.22.13.15 219, 225  
3.22.13.17 226  
3.22.13.18 226  
3.22.13.19 226  
3.22.13.20 226  
3.22.13.22 226  
3.22.13.24 200  
5.5.1.13 151  
5.5.1.17 152  
5.5.3.1 151, 156  
5.5.3.8 156  
5.5.5.5 154  
5.5.5.11 159  
5.7 151, 220  
5.10 221  
5.13.1 154, 159  
5.13.7 154, 222  
5.13.14 154  
5.13.20 159  
13.1 7  
13.1.2.4 55  
13.5 46  
13.12.7 52, 56  
13.12.13 52  
13.12.14 15  
13.15 8, 49, 60  
13.19 13, 49  
14.1 20  
14.5 20, 44  
14.9 23, 149  
14.13.1 47, 150  
14.13.7 23  
14.13.13 27  
14.13.17 177  
14.13.18 177  
14.13.19 177  
14.15.1 8, 49, 60  
14.17.1 27  
15.1 7, 36  
15.5 35  
15.8 36  
15.12.1 50, 61, 62, 65, 78  
15.12.5 53  
15.13 37, 47  
15.16 37  
15.18 37, 45, 50, 65, 78  
16.1 60, 78  
16.3 99  
16.3.1 98, 99  
16.3.2 99  
16.3.3 99, 101  
16.3.4 62, 99  
16.3.5 62, 99  
16.3.6 62, 100, 101  
16.3.13 61  
16.3.19 90  
16.5 90  
16.6 61, 81, 91  
16.7 61, 81  
16.8 83  
16.9 90  
16.10 92, 215  
16.11 52, 62, 94, 216  
16.12 48, 52, 62, 95  
16.13.1 88  
16.13.13 89, 107  
16.16 90  
16.17 90  
16.18 94, 100  
16.11 217  
16.19 75, 215, 217  
16.21 43, 52, 64, 101, 106, 109  
16.23 64, 102  
16.24 77  
17.1 104, 216  
17.2 104, 216  
17.3 104, 216  
17.4 107  
17.5 106, 108  
17.7 107, 217  
17.13.12 111  
17.13.16 107  
17.13.17 107  
17.13.22 111  
17.23 112  
17.24 105

- 18.4.10 177
  - 18.14 175
  - 18.17 224
  - 18.18 177, 224
  - 18.22.1.1 119
  - 18.22.1.6 124
  - 18.22.1.10 126
  - 18.22.1.11 122
  - 18.22.1.12 122
  - 18.22.1.13 222
  - 18.22.1.15 129
  - 18.22.1.18 129
  - 18.22.1.22 122
  - 18.22.1.23 123
  - 18.22.2.1 130
  - 18.22.2.4 130, 156
  - 18.22.2.6 116
  - 18.22.2.7 116
  - 18.22.3.9 134
  - 18.22.3.1 131, 132
  - 18.22.3.5 133
  - 18.22.03.6 131
  - 18.22.3.6 134
  - 18.22.3.8 133
  - 18.22.4.1 147
  - 18.22.4.3 147
  - 18.22.4.4 147
  - 18.22.4.5 147
  - 18.22.4.6 147
  - 18.22.4.10 147
  - 18.22.4.11 147
  - 18.22.4.12 147
  - 18.22.4.13 148
  - 18.22.4.14 148
  - 18.22.4.15 148
  - 18.22.5.5 157
  - 18.22.5.11 150, 159
  - 18.22.5.13 155, 162
  - 18.22.5.17 161
  - 18.22.5.24 157
  - 18.22.6 138
  - 18.22.7 136
  - 18.22.8 136
  - 18.22.9 145
  - 18.22.10 136
  - 18.22.11 136
  - 18.22.12 147
  - 18.22.13 115, 139, 142, 150, 156, 219
  - 18.22.14 143, 219
  - 18.22.15 143, 219
  - 18.22.16 143
  - 18.22.17 144, 219
  - 18.22.18 144, 155, 220
  - 18.22.20 143
  - 18.22.21 144, 220
  - 18.22.22 143
  - 18.22.24 116
  - 18.24 173
  - 19.1.1 229
  - 19.1.13 230
  - 19.2.1 231
  - 19.3.1 232
  - 19.3.14 232
  - 19.7 234
  - 19.11 235
  - 19.13 236
  - 19.20 238
  - 19.23 235
  - 19.24 229
  - 22.1 254
  - 22.2 254
  - 22.7.1 241
  - 22.7.5 246
  - 22.7.7 247
  - 22.7.11 248
  - 22.7.12 248
  - 22.7.13 252
  - 22.7.17 244, 245
  - 22.7.23 253
  - 22.9 263
  - 22.13 78, 258, 262
  - 22.21 265
  - 22.22 265
  - 23.1 279
  - 23.2 280
  - 23.3 271, 280
  - 23.5 58, 281
  - 23.7 58, 281
  - 23.8 283
  - 23.10 58, 283
  - 23.11 283
  - 23.12 58
  - 23.14 58
  - 23.16 278
  - 23.17 58, 278
  - 23.22 279
  - 23.24 269
  - 24.1 88, 286
  - 24.4 288
  - 24.5 288
  - 30.13.19 52
  - 36.2.21.1 200
  - 36.9.11 78
  - 36.9.12 116
- A**
- accounting close
    - joint work orders 43
    - work order 101
  - accounts
    - department 19
  - Action Message Report 281
    - co-products/by-products 58
  - Action Message Review/Update 281
    - co-products/by-products 58
  - action messages
    - material requirements planning (MRP) 281
  - Actual Pay Rate Maintenance
    - labor rate 105
  - Adjust Valuation Report 148
  - advanced repetitive 113–167
    - adding operations and 89
    - backflush transactions 115
    - changeover times 124
    - consume earliest open 115
    - contrast with repetitive 114
    - creating schedules 129
    - Cumulative Completed Maintenance 116

- cumulative orders 135
- End Eff Days field 118
- line schedule simulations 126
- milestone operations 125
- MRP planned orders 128
- picklists 131
- production lines 119
- reports 147
- routings 124
- schedules
  - creating 129
  - explosion 130
- subcontracts 148
  - processing 115
- tracing WIP 219–220
- transactions 138
  - backflush 139, 142
  - common data 139
  - common information 139
  - labor 143
  - method change variance 141
  - post accumulated usage variances 145
  - rate variance 140
  - reject 143
  - rework 144
  - scrap 144
  - WIP adjust 144
- updating schedules 129
- warning messages 140
- Advanced Repetitive Accounting Control 116
- Advanced Repetitive Backflush 150
- Advanced Repetitive defaults 152
- advanced repetitive scheduled orders 150
- Advanced Repetitive Scrap Transaction 155
- allocate
  - production line percentages 122
- Allocated status, work orders 184
- allocated work orders 84
- alpha factor
  - forecasting 245
- alternate
  - base processes 49
    - work orders for 61
  - formulas 8
  - routings 26
    - base process 49
  - structures 8
- Alternate Routing Maintenance 8, 26
  - co-products/by-products 49, 60
- Alternate Structure Maintenance 8
  - co-products/by-products 49, 60
- alternate subcontractors 148
- API. *See* application programming interface (ATP)
- application programming interface (API)
  - and Subcontractor Shippers frame 166
  - updating shippers 167
  - user interface suppression
- approval
  - MRP planned orders 283
- archive/delete
  - forecast detail 253
  - quality orders 235
  - work orders 102
- assigning work order and operation 115, 156
- ATP. *See* available-to-promise (ATP)
- Auto Labor Report field 125
- automatic
  - completion of operations 108
  - labor backflush 125
- available-to-promise (ATP) 259
- average cost
  - co-products/by-products 52, 54
- Average Cost Method Maintenance
  - co-products/by-products 53
- B**
- backflush
  - co-products/by-products 62
  - labor automatically 125
  - locations 126
  - method
    - co-products/by-products 46
    - work order receipt 96
  - transactions 142
  - work order
    - quantity to issue calculation 96
- Backflush Transaction 115, 139, 142, 156, 219
  - fields 142
  - test results 235
  - tracing WIP 219
- base process 41
  - alternate 49
  - alternate routings 49
  - BOM/Formula codes 41
  - planning for 41
  - restricting inventory transactions 44
  - setting up item 44
- batch
  - formula quantity type 35
  - quantities 11
  - size for formula 35
  - work orders 83
- Batch status, work orders 184
- bills of material. *See* product structures
- BOM codes 7
  - as parent items 7
  - co-products/by-products 45
  - linking to items 8
- BOM Registration Maintenance 204
- BOM. *See* product structures
- burden 22
- by-products
  - costs 51
  - definition 40
  - lead times 55
  - Material requirements planning (MRP) 56
  - recyclable 47
  - setting up items for 45
- C**
- calculating
  - forecasts 246
  - picklists 132
- calculation commitment categories 185
- calculations for component check 184
- Calendar Maintenance
  - work center calendar 19
- calendars

- shop
  - MRP use of 282
  - work center 19
- capacity
  - adjusting 289
  - department 286
  - operation 24
  - shift 123
  - work center 23, 286
- capacity requirements planning (CRP) 285–290
  - adjusting capacity 289
  - adjusting load 289
  - defining capacities 286
  - department labor capacity 19
  - lead times 27
  - load reports 288
  - operation capacity 24
  - scheduling operations 287
  - work center capacity 23
- Certificate of Analysis Print 238
- changeover times 124
- checking material shortage 186
- closed work orders 84
  - close date 100
- closing
  - cumulative orders 136
- closing subcontract shippers 161
- Co/By-Product Maintenance 50, 61, 62
  - Quantity Complete Method field 65, 78
- Co/By-Product Work Order Inquiry 61
- Co/By-Products Cost Report 52, 56
- combining receipt and inventory placement 148
- commitment categories 185
- component availability calculations 184
- component check, example 179
- component check, examples 186
- Component Status field 184
- component, list of status 184
- composite lead times 15
- configured products
  - product structures for 11
- connecting shippers to received items 159
- connecting subcontract POs to a routing 153
- consume earliest open 115
- consume forecast
  - forecasting 255
- control program
  - Advanced Repetitive 116
  - MRP 269
  - Quality Management 229
  - Repetitive 173
  - Shop Floor Control 105
  - WIP Lot Trace 200
  - Work Order 77
  - Work Order Accounting 78
- co-products/by-products 39–71
  - average costs 52
    - accounting for 54
    - allocation methods 53
  - backflush 62
    - method 46
  - base processes
    - alternate routings 49
    - BOM/Formula codes 41
    - defined 41
    - defining alternate 49
    - defining co-products for 45
    - item status codes 44
    - lead times 55
    - material requirements planning (MRP) 56, 57
    - planning for 41
    - planning for multiple 56
    - restricting inventory transactions 44
    - setting up items for 44
    - WO status codes 59
  - BOM/Formula codes 45
  - by-products
    - costs 51
    - defined 40
    - freezing costs 51
    - lead times 55
    - material requirements planning (MRP) 56
    - setting up items for 45
  - co/by-product structures 45
  - co-products
    - alternate base processes 42
    - average costs 52
    - cost allocation percentages 46, 50
    - defined 40
    - demand for 58
    - material requirements planning (MRP) 56, 58
    - planning/demand for 41
    - setting up items for 45
    - substitute items 49
  - cost allocations
    - by price 53
    - by receipt quantity 54
  - costs
    - by-products 51
    - reviewing 55
    - rolling up 52
  - features 40
  - joint order sets 59
    - accessing, modifying 59
    - accounting for 64–70
    - archiving 64
    - deleting 64
    - from alternate base processes 61
    - printing 61
    - releasing 61
    - reviewing 61
  - lead times
    - rolling up 55
  - lots 64
  - material requirements planning (MRP) 45, 56
    - action messages 58
    - multiple base processes 56
    - planned order reports 58
    - planned work orders 58
    - summary reports 58
  - mix variances
    - accounts 43, 61
    - calculating 43, 65–70
  - Planned Order Reports 58
  - product line 44
  - quantity complete method 46, 65–70
    - MAX 68
    - MIN 69

- ORD 70
  - SUM 67
  - SUMC 67
  - receiving 62
  - recyclable by-products 47
  - routings 41
  - scrap 62
  - setting up an operation 42
  - shop floor control transactions 64
  - sites 44
  - structures 41
  - types of 40
  - unexpected items
    - receiving 63
  - unit of measure
    - conversion factors 48
  - unplanned items
    - receiving 63
  - WO status codes 59
  - work centers 44
  - work orders 59
    - accounting close 43, 64
    - allocated status 60
    - batch status 60
    - closed status 60
    - exploded status 60
    - firm status 60
    - mix variance accounts 43
    - planned status 60
    - released status 60
    - routable 61
    - work-in-process amounts 43
  - copying
    - forecasts 248
    - formulas 36
    - processes 37
  - costs
    - allocating to co-products 46, 50
    - allocation methods
      - co-products/by-products 53
    - average
      - co-products/by-products 52
    - freezing
      - by-products 51
    - rolling up
      - co-products/by-products 52
  - creating subcontract orders 151
  - criteria templates 246
    - creating 241
    - modifying 241
  - Cumulative Completed Maintenance 116
  - cumulative ID, expired 160
  - cumulative lead time 14
  - Cumulative Lead Time Roll-Up 15
    - co-products/by-products 55
  - Cumulative Order Browse 136
  - Cumulative Order Close 136
    - transferring WIP 137
  - Cumulative Order Cost Report 147
  - Cumulative Order Create 136
  - Cumulative Order Maintenance 138
    - changing effective dates 138
    - closing orders 136
  - Cumulative Order Report 136
  - cumulative orders 135
    - closing 136
    - component costs 140
    - creating in batch 136
    - labor and burden rate variance 141
    - subcontract rate variance 141
    - Work Order module 81
  - cumulative work order ID, in shipper 157
  - Current Work Center and Machine frame 213
  - customizing
    - forecasting methods 245
  - cyclical pattern 243
- ## D
- date
    - work order 86
  - delete/archive
    - forecast detail 253
    - quality orders 235
    - transactions 112
    - work orders 102
  - demand patterns
    - sales history 242
  - demand row 186
  - Demand/Supply Detail Browse, PQOH column 185
  - Demand/Supply Summary Browse 185
  - Department Maintenance 20
  - departments
    - account codes 19
    - accounts 19
    - capacity 286
    - labor capacity 19
    - labor feedback by 105
    - work center 19
  - Destination Work Center and Machine frame 206
  - destructive testing 238
  - Detail Forecast Delete/Archive 253
  - Detail Forecast Maintenance 247
    - modifying results 247
  - dispatch lists
    - work order 94, 100
  - dispatching work orders 100
  - Down Time by Reason Report
    - shop floor control 107
  - Down Time Report 107
  - Down Time Transaction 143
  - downtime 106
  - due dates
    - work order 86
- ## E
- EDI eCommerce 156
  - effective dates
    - product structures 11
  - efficiency 112
    - employee 105
  - employee code, when scrapping 164
  - Employee Create (36.1.7.1) 105
  - employees
    - efficiency 105
    - labor feedback 104
  - End Eff Days field 118
  - engineering change orders 15
  - engineering effectivity 15

- enhanced reports 292
- exceptions
  - BOM components 204
  - BOMs 204
  - routing 202
  - routing operation 203
- expense
  - work orders 81
- expensed items 13
- Exploded status, work orders 184
- exploded work orders 84
- explosion
  - advanced repetitive schedules 130

**F**

- FAS. *See* final assembly (FAS)
- feature codes
  - configured product 11
- final assembly (FAS)
  - work orders 80
- finished items 165
- firm category 185
- firm planned work orders 83
- Firm status, work orders 184
- first article inspections 237
- fixed order quantity (FOQ) 273
- floor stock 13
  - expensed items vs 13
- FOQ (Fixed Order Quantity) 273
- Forecast Maintenance 254
- Forecast Worksheet Maintenance 254
- forecasting 239–257
  - adding methods 245
  - alpha factor 245
  - calculating forecasts 246
  - combining criteria templates 250
  - consumption 255
    - forward and backward 255
  - copying
    - criteria templates 250
    - forecasts 248
    - results 250
  - creating detail records 246
  - creating forecasts 240
  - creating forecasts manually 247
  - criteria templates 241, 246
  - detail records
    - loading into summary forecast 253
    - loading methods 253
  - horizon 241
  - material requirements planning (MRP) 252
  - methods 243
    - best fit 244
    - classic decomposition 244
    - creating custom 245
    - double exponential smoothing 244
    - double moving average 244
    - simple regression 244
    - Winter's linear exponential smoothing 244
  - modifying results 247
  - multiplicative factors 249
  - net forecast calculation 255
  - new items 251
  - rolling forecasts 241

- simulations 240
- single items 251
- summary forecast records 252
- Formula Code Maintenance 7, 36
- Formula Copy 36
- Formula Maintenance 35
  - co-products/by-products 48
  - lead time offset 91
  - work order 85
- formulas 33–36
  - batch size 35
  - batch type 35
  - co-product/by-product 36
  - copying 36
  - defining 34
  - defining BOM/Formula code 36
  - MRP use of 276
  - setup for 34
  - used for multiple items 7
- freezing costs
  - by-products 51

**G**

- general ledger (GL)
  - period end 102
- global phantoms 8

**H**

- horizon
  - forecasting 241
- horizontal pattern 243

**I**

- indicating quantity scrapped 155
- Input/Output Inquiry 288
- Input/Output Report 111, 288
- Integrate with SA field
  - effect on forecasting 241
- inventory
  - moving finished items into 165
  - placement of finished goods 148
- inventory audits 237
- Inventory Control
  - picking logic 89
  - work order 90
- Inventory Detail Report
  - auditing items 237
- inventory sampling 232
- Issues–Unplanned
  - floor stock 13
- issuing
  - work order components 91
- Item Cost Maintenance
  - co-products/by-products 51
- Item Master Maintenance 130, 149
  - base process item 44
  - co-products/by-products 45, 51
  - planning parameters 271
- Item Planning Data Frame 149
- Item Planning Maintenance
  - BOM code 7
  - co-products/by-products 45
  - MRP use of 271
  - phantoms 8

- Pur/Mfg code 81
  - routing code 26
  - Item Specification Maintenance 230
  - Item Status Code Maintenance
    - co-products/by-products 44
  - Item Substitution Maintenance 13
    - co-products/by-products 49, 63
  - items
    - expensed 13
    - key 90
    - master scheduled 257, 271
    - planning parameters 271
    - specifications for 230
  - Item-Site Cost Maintenance
    - co-products/by-products 51
  - Item-Site Planning Maintenance 130
    - BOM code 7
    - co-products/by-products 44, 45
    - MRP use of 271
    - phantoms 8
    - routing code 26
- J**
- joint order sets 59
    - printing 61
    - releasing 61
    - reviewing 61
- K**
- key items
    - work orders 90
- L**
- labor 22
    - advanced repetitive transactions 143
    - backflushing automatically 125
    - nonproductive 107
    - reporting feedback 104
    - reports 109
      - down time 111
      - input/output 111
      - transactions 109
      - utilization and efficiency 112
  - labor feedback
    - departments 105
    - employees 104
    - item quantities 105
    - test results 235
    - work centers 105
  - Labor Feedback By Employee 216
  - Labor Feedback by Employee 104
  - Labor Feedback By Work Center 216
  - Labor Feedback by Work Center 104
  - Labor Feedback By Work Order 216
  - Labor Feedback by Work Order 104
    - test results 236
  - Labor WIP Lots frame 211
  - labor, reporting feedback
    - using WIP Lot Trace 216
  - lead times 274
    - changing 28
    - composite 15
    - co-products/by-products 55
    - cumulative 14
    - manufacturing 29
    - move 27
    - operation 28
    - queue 27
    - run 27
    - scheduling production lines 128
    - setup 27
    - subcontract 27
    - wait 27
  - Line Allocation Inquiry 122
  - Line Allocation Maintenance 122
  - Line Changeover Maintenance 124
  - Line Schedule Workbench 126
    - co-products/by-products 71
    - deleting sequence records 129
    - lead times 128
    - multiples 127
    - production quantities 128
    - sequence numbers 128
  - Line Utilization Report 129
  - lines
    - production 119
    - list of status for components 184
    - load reporting 288
    - local phantoms 9
  - Lot Actual Bill Inquiry
    - co-products/by-products 64
  - Lot Actual Bill Report 226
  - lot control
    - co-products/by-products 64
  - lot numbers, WIP Lot Trace
    - custom number format 198
  - Lot Where-Used Inquiry
    - co-products/by-products 64
  - Low Level Code Update 279
- M**
- Manage Materials for Production Line 177
  - Manage Materials for Work Center 177
  - manufacturing
    - lead time 27, 29
    - yield 30
  - master
    - specifications 229
  - master production scheduling (MPS) 257–265
    - available-to-promise (ATP) 259
    - computer-assisted scheduling 258
    - creating schedule 257
    - fully automatic 257
    - fully manual scheduling 258
    - items for 257, 271
    - master schedule orders 262
    - MRP use of 268
    - multilevel 259
    - multilevel scheduling techniques 261
    - planning bills 260
    - production forecast 261
    - repetitive schedules 262
    - seasonality 263
  - Master Schedule Detail Inquiry 265
  - Master Schedule Detail Report 265
  - Master Schedule Order Maintenance 78, 258, 262
  - Master Scheduling Workbench 167
  - Master Specification Maintenance 229

- material requirements planning (MRP) 267–283
  - action messages 281
  - by-products 56
  - co-products/by-products 45, 56
    - action messages 58
    - base processes 56, 57
    - co-products 56, 58
    - planned order reports 58
    - planned work orders 58
    - summary reports 58
  - demand 268
  - demand sources 268
  - forecasting 252
  - item planning data 271
  - items not seen by 275
  - lead times and 274
  - Line Schedule Workbench 128
  - multiple base processes 56
  - output 280
  - past due forecasts 256
  - pegged requirements 278
  - repetitive explosion 131
  - safety stock 273
  - scrap factor in 11
  - shop calendar 282
  - substitute items 14
  - supply 268
  - supply sources 269
  - yield calculations 29, 270, 274, 277
- material shortage, examples of check 186
- matrix in Supply/Demand Summary 186
- messages
  - advanced repetitive warnings 140
  - MRP action 281
- method change variance (MCV) 141
- milestones
  - operations 24, 125
  - operations and WIP lot tracing 196
- mix variances
  - accounts
    - co-products/by-products 43, 61
  - calculating
    - co-products/by-products 65–70
- modifying
  - work order bill 88
  - work order routings 89
  - work orders 88
- Monitor Material Shortages 177
- Monitor Material Shortages, example 182
- Move Next Op field 150
- Move Next Op in Backflush Transaction 156
- moving items into inventory 165
- MPS. *See* master production scheduling (MPS)
- MRP Control 269
- MRP Detail Inquiry 278
- MRP Detail Report 278
  - co-products/by-products 45, 58
- MRP Summary Report
  - co-products/by-products 45
- MRP totals 185
- MRP. *See* material requirements planning (MRP)
- multiple sites
  - work order components 92
- Multiple Work Order Release/Print 81, 89

- co-products/by-products 61
- Multiple Work Order Status Change
  - co-products/by-products 58
- multiplicative factors
  - forecasting 249

## N

- negative quantities on receipt 160
- Net Change MRP 279
- non-milestone backflushing 115
- nonproductive labor 107
- Non-Productive Labor Feedback 107, 143
- Number Range Maintenance 200
- number range management (NRM)
  - WIP lot/serial numbers 198

## O

- one time only (OTO) 273
- Operation Complete Transaction 108
  - operation status 106
- Operation Cost Calculation 177
- Operation Cost Inquiry 177
- Operation Cost Report 177
- Operation Move Transaction
  - queue status 106
- Operation Scrap Transaction 107
  - tracing WIP scrap 217
- Operation Transaction Inquiry 147
- Operation Transaction Numbering Report 111
- operation, specifying code 151
- operations
  - automatic completion 108
  - capacity 24
  - changes to 23
  - lead time 28
  - lead time calculation 28
  - load 288
  - milestone 24, 125
  - product structure 12
  - scheduling 88, 286
  - standard 23
  - status 106
    - complete 106
    - hold 107
    - queue 106
    - running 106
    - setup 106
    - subcontract 29
    - yield 29
- Operations History Delete/Archive 112
- Operations Numbering Report 147
- order modifiers 273
- order pegging 278
- order policies
  - MRP use of 273
- OTO 273

## P

- parent items
  - product structures 6
- performance
  - efficiency 112
  - productivity 112
  - utilization 112

- period order quantity (POQ) 273
  - phantom
    - use up logic 15
  - phantoms 8
    - global 8
    - identifying 8
    - local 9
    - use-up logic 9
  - picklists
    - processing flow 131
    - repetitive 131
    - reprinting 91
    - work order 90
  - plan category 185
  - plan orders parameter 271
  - Planned Order Reports
    - co-products/by-products 58
  - Planned Purchase Order Approval 283
  - Planned Repetitive Sched Approve 283
  - Planned status, work orders 184
  - Planned Work Order Approval 283
    - co-products/by-products 58
  - planned work orders 83, 282
  - planning
    - bills for 260
    - capacity requirements 285
    - master production schedule (MPS) 257
    - material requirements 267
    - shipment performance monitoring 148
  - Planning and Scheduling Workbench 167
  - PO Shipper Maintenance 154
  - PO Shipper Receipt 159
  - POQ 273
  - Post Accumulated Usage Variances 145
  - PQOH column, Demand/Supply Detail Browse 185
  - primary run sequence 272
  - printing
    - picklists 133
  - Procedure Maintenance 231
  - Process Definition Copy 37
  - Process Definition Maintenance 37
    - co-products/by-products 47
    - run time 27
  - process inspection 236
  - Process/Formula Maintenance 37
    - co-products/by-products 45, 50, 62
    - Quantity Complete Method field 65, 78
  - processes 36–38
    - batch quantity 37
    - copying 37
    - defining 36
    - manufacturing 11
  - product definition 1
  - Product Line Maintenance
    - co-products/by-products 44
  - product lines
    - co-products/by-products 44
  - Product Structure Code Maintenance 7
  - Product Structure Cost Report
    - co-products/by-products 55
  - Product Structure Cost Roll-Up
    - co-products/by-products 52
    - product structure Op field 12
  - Product Structure Maintenance
    - co-products/by-products 46
    - lead time offset 91
    - planning bills 260
    - work order BOM 85
  - product structures 5–15
    - alternate 8
    - alternate routings 8
    - BOM codes 7
    - component quantities 11
    - configured products 11, 13
    - effective dates in 11
    - MRP use of 276
    - operation codes 12
    - phantoms 8
    - reference codes 11
    - repetitive 130
    - scrap 11
    - substitutions 13
    - type codes 12
    - used for multiple items 7
  - Production Line Maintenance 119
  - production lines 119
    - changeover time 124
    - schedules 126
    - shifts 122
  - Production Scheduling Workbench 167
  - productivity 112
  - profit margin
    - forecasting 251
  - Pur/Mfg code
    - MRP use of 272
  - Purchase Direct Materials 177
  - Purchase Order Maintenance 151
    - co-products/by-products 70
    - using to trace WIP 220
  - Purchase Order Percents Frame 152
  - Purchase Order Receipts 154, 159
    - co-products/by-products 70
    - tracing WIP receipts 221
  - Purchase Order Returns 154
    - tracing WIP 222
- Q**
- quality management 227–238
    - Certificate of Analysis Print 238
    - destructive testing 238
    - first article inspections 237
    - inspection 233
    - inspection site 229
    - inventory audits 237
    - inventory sampling 232
    - item specification 230
    - master specifications 229
    - procedures 231
    - process inspection 235
    - process validation 237
    - quality orders 233
    - quarantine 228
    - specifications 228
      - values for 230
    - test results 236
    - Test Results Maintenance 236
  - Quality Management Control 229
  - Quality Order Delete/Archive 235

- Quality Order Maintenance 234
- Quality Order Results Entry 235
  - destructive testing 238
- quality orders
  - creating 234
  - deleting 235
  - entering results 235
  - inspection 233
- quarantine 228
- queues
  - lead time component 27
  - operation
    - input 138
    - output 138
    - reject 138
  - operation status 106
- R**
- rate variance
  - advanced repetitive 140
- Reason Codes Maintenance
  - nonproductive labor 107
- Recalculate Capacity Plan 286
  - effect on operation schedules 88
- Receipt Data Input frame 165, 167
- receipt date, work order 101
- receipt of subcontract items 148
- receiving against a subshipper 160
- receiving subcontract items 159
- recyclable by-products 47
- reference codes
  - product structures 11
- Regenerate Materials Plan 280
- Regulatory Attributes
  - and WIP Lot Trace 190
    - lot numbers 95
- Regulatory Attributes Control
  - co-products/by-products 49, 63
- Reject Analysis Report 147
- Reject Transaction 143
- release category 185
- Release Production Order by Work Center, example 181
- Release Production Orders by Production Line 177
- Release Production Orders by Work Center 177
- Released status, work orders 185
- released work orders 84
- releasing
  - work orders 89
- repetitive 171–177
  - completions 175
  - consume forward/backward 173
  - contrast with advanced repetitive 114
  - cumulative orders 174
  - differences from advanced repetitive 172
  - milestone operations 175
  - picklists 131
    - calculation 132
  - setting up 172
  - tracing WIP 223–224
  - transactions 174
    - reporting 175
    - scrap cost 177
- Repetitive Control 173
  - advanced 116
    - consume forward and backward 173
    - Next Picklist field 133
- Repetitive Labor Transaction 175
  - test results 235
- Repetitive module
  - co-products/by-products 71
- Repetitive Operations Accounting Report 177
- Repetitive Picklist Calculation 131, 132
  - troubleshooting 133
- Repetitive Picklist Delete 134
- Repetitive Picklist Print 133
  - product structure Op field 13
- Repetitive Picklist Transfer 131, 134
- Repetitive Picklist Undo 133
- repetitive picklists
  - deleting 134
  - inventory transfer 134
  - printing 133
- Repetitive Reject Transaction
  - WIP Lot Trace frames 224
- Repetitive Schedule Explosion
  - co-products/by-products 71
- Repetitive Schedule Maintenance
  - co-products/by-products 71
- Repetitive Schedule Update 129
- repetitive schedules
  - master production scheduling (MPS) 262
- Repetitive Scrap Transaction 177
  - WIP Lot Trace frames 224
- repetitive. *See also* advanced repetitive
- reports
  - labor 109
  - reports, enhanced 292
- reprinting
  - picklists 91
- returning subcontract items 161
- Rework Analysis Report 147
- Rework Transaction 144
  - tracing WIP 219
- rework work orders 80
- rolling forecasts 241
- routable work orders 81
- Routing Cost Roll-Up 27
  - product structure Op field 12
  - yield percentage 274
- Routing Maintenance 150
  - co-products/by-products 47
  - overlap units 88
  - quality operations 235
  - run time 27
- Routing Maintenance (Rate Based)
  - run time 27
- Routing Registration Maintenance 202
- Routing Update
  - applying changes 23
- routing, connection to subcontract POs 153
- routings 25–27
  - advanced repetitive requirements 124
  - alternate 26
  - co-products/by-products 61
  - defaults 26
  - defining 25
  - lead times and 18
  - quality management 235

- site-specific defaults 26
  - uses of 18
  - work orders 85
  - Run Labor Transaction 143
    - Labor WIP Lots frame 219
  - run sequences 272
  - run time 106
- S**
- safety stock 273
  - safety time
    - MRP use of 275
  - sales history
    - demand patterns
      - cyclical 243
      - horizontal 243
      - seasonal 243
      - trend 243
    - forecasting use of 242
    - underlying patterns 242
  - Sales Order Control
    - Consume Forward field 256
    - Integrate with SA field 241
  - Sales Order Maintenance
    - abnormal demand 255
    - consuming forecast 255
  - sales orders
    - abnormal demand 255
    - demand 255
  - Sample by Lot Interval Inquiry 232
  - Sampling Pattern Maintenance 232
    - Days to Expire field 232
    - lot interval 232
  - Schedule Delete 116
  - Schedule Explosion 130, 156
  - Schedule Maintenance 130
  - Schedule Print 156
  - Schedule Update from MRP 151, 156
    - co-products/by-products 71
  - Scheduled Order MRP % Maintenance 152
  - scheduled orders
    - repetitive subcontracts 150
  - scheduled work orders 81
  - schedules
    - advanced repetitive
      - explosion 130
    - line simulations 126
    - repetitive 129
    - work orders 85
  - scheduling
    - See also* master production scheduling (MPS)
  - scrap
    - compared to yield 29
    - component loss 97
    - co-products/by-products 62
    - cycle 98
    - material requirements planning (MRP) 11
    - product loss 98
    - product structures 11
    - quantities by order 98
    - types 217
    - WIP lot/serial tracing 217
  - Scrap Analysis Report 147
  - scrap quantities during receipt 161
  - Scrap Transaction 144
    - tracing WIP 220
  - scrap transactions 163
  - Scrap Valuation Report 148
  - scrapping specified quantities 155
  - scrapping subcontract items 148
  - scrapping unreturned material 155
  - Seasonal Build Maintenance 263
  - seasonal pattern 243
  - seasonality
    - master scheduling for 263
  - secondary run sequence 272
  - security
    - site 76
  - Selective Materials Plan 271, 280
    - master production scheduling (MPS) 258
  - setting up subcontract items 149
  - Setup Labor Transaction 143
    - Labor WIP Lots frame 219
  - setup time 106
  - Shift Maintenance 122
  - Shift Report 123
  - shifts
    - advanced repetitive 122
    - capacity 123
  - shippers, connecting to items 159
  - shop floor control 103–112
    - co-products/by-products 64
    - labor feedback 104
    - nonproductive labor 107
    - operation close 108
    - reports 109
  - Shop Floor Control program 105
  - Simulated Batch Ingredient Check
    - local phantoms 9
  - Simulated Forecast Calculation 246
  - Simulated Picklist Item Check 9
    - local phantoms 9
  - Simulation Criteria Maintenance 241
  - Simulation Structure Cost Roll-Up
    - co-products/by-products 52
  - Simulation To Simulation Copy 248
    - copying forecasts 250
    - multipliers 249
  - Simulation To Summarized Forecast 252
  - simulations
    - forecast 240
    - line schedules 126
  - Single Item Simulation Copy 248
    - copying forecasts 251
    - multipliers 249
  - Site Maintenance
    - co-products/by-products 44
  - sites
    - co-products/by-products 44
    - security for 76
    - work order control by 76
  - specifications 228
    - values for 230
  - specifying active lines when allocating MRP % 152
  - specifying received subcontract quantities 160
  - splitting work orders 90
  - Standard Operation Maintenance 23, 149
  - standard operations 23

- changes to 23
  - overlap 24
  - standard work orders 79
  - status
    - operation 106
    - work order 82
  - status for components 184
  - status for work orders 184
  - Status ID field 184
  - Sub Shipper Issue 150, 159
  - Sub Shipper Maintenance 157
    - WIP Lot Move Data frame 222
  - subcontract
    - tracing WIP 218
  - subcontract cost, specifying 150
  - subcontract fields in Routing Maintenance 150
  - Subcontract Item Status Inquiry 161
  - subcontract items
    - connecting shippers to received items 159
    - receipt 148
    - receiving 159
    - reports 165
    - returning 162
    - scrapping 148
    - scrapping during receipt 161
    - scrapping unreturned material 155
    - setting up 149
    - specifying in an order 151
    - specifying received quantities 160
    - viewing subcontractors during receipt 154
  - subcontract lead time, specifying 150
  - subcontract operation during backflush 115
  - subcontract operation, assigned during backflush 156
  - Subcontract Order MRP % Maint 152
  - subcontract orders, creating 151
  - Subcontract Routing Op/PO Maint 152
  - subcontract shipper
    - closing during receipt 161
    - reopening during return 162
    - tracking 160
    - tracking through return 161
  - Subcontract Shippers frame 154
  - Subcontract Shipping Control 153, 157
  - subcontract visibility 165
  - Subcontractor Scrap Maintenance 162
  - Subcontractor Scrap Transaction 155
  - subcontracts
    - advanced repetitive 148
    - advanced repetitive processing 115
    - labor and burden rates 29
    - life cycle 94
    - operations 29, 93
    - routings for 126
    - scheduled orders 150
  - substitute items
    - co-products/by-products 49
    - product structures 13
  - Supplier Lot Transaction Report 226
  - Supplier Scheduled Order Maintenance 151
  - suppliers, unassigned 154
  - supply
    - sources for MRP 269
  - supply and demand MRP totals 185
  - Supply row 186
  - Supply/Demand Summary matrix 186
- T**
- templates
    - forecasting 241
  - Test Results Maintenance 236
  - The 105
  - time fence
    - MRP use of 275
  - transactions
    - deleting and archiving 112
  - transactions, scrap 163
  - transfers
    - inventory
      - repetitive picklists 134
    - WIP 137
  - type
    - product structure 12
    - work order 79
- U**
- unassigned suppliers 154
  - unit of measure
    - co-products/by-products
      - conversion factors 48
  - Unit of Measure Maintenance
    - co-products/by-products 48
  - unplanned items
    - co-products/by-products 63
  - Unplanned Receipts
    - co-products/by-products 63
  - unreturned material 155
  - usage variances
    - component 146
    - co-products/by-products 66
    - labor and burden 146
    - types 146
    - WIP material scrap 146
  - User Forecast Method Maintenance 244, 245
  - user ID captured 100
  - utilization 112
- V**
- variance
    - calculating mix 65
    - labor rate 105
    - posting at shop floor control 78
  - view multiple subcontractors during receipt 154
  - viewing subcontract operations 165
- W**
- When 163
  - WIP Adjust Transaction 144
    - WIP Lot Queue Adjust frames 220
  - WIP Adjustments Analysis Reports 147
  - WIP Lot Browse 226
  - WIP Lot Convert Trans Report 219, 225
  - WIP Lot Input Queue Issue Data frame 207
  - WIP Lot Input Queue Scrap Data frame 210
  - WIP Lot Inquiry 226
  - WIP Lot Inventory Status Report 223
  - WIP Lot Move Data frame 212
  - WIP Lot Non-Convert Trans Report 226
  - WIP Lot Output Queue Issue Data frame 216

- WIP Lot Output Queue Receipt Data frame 208
- WIP Lot Output Scrap Data frame 210
- WIP Lot Reject Data frame 209
- WIP Lot Reject Scrap Data frame 210
- WIP Lot Rework Data frame 211
- WIP Lot Scrap Data frame 209
- WIP Lot Trace
  - and Regulatory Attributes 190
  - data collection frames 206–213
  - overview 190
  - pre setup issues 199
  - reports 224–226
  - setup 199
  - subcontract process 220–223
- WIP Lot Trace Control 200
- WIP Lot Trace module 77
- WIP Lot Where Used Report 226
- WIP Status Inquiry 147
- WIP Status Report 147
- WIP Valuation Report 148
- WLT-controlled BOMs and routings 206
- Work Center Maintenance 20
  - co-products/by-products 44
  - labor rate 105
- work center, specifying 150
- Work Center/Routing Standards Maintenance
  - alternate work centers 27
- work centers 20–23
  - alternate standards 27
  - calendars 19
  - capacity 23, 286
  - co-products/by-products 44
  - department accounts 19
  - departments 19
  - labor feedback 105
  - routing standards 27
- Work Order Accounting Close 84
  - co-products/by-products 43, 52, 55, 64
  - effects on GL 101
  - operation status 106, 109
- Work Order Accounting Control 78
- Work Order Attribute Maintenance
  - co-products/by-products 64
- Work Order Backflush 217
- Work Order Bill Maintenance 88
- Work Order Bill Shortage by Item Report 90
- Work Order Bill Shortage Report 90
- Work Order by Item Report 99
- Work Order by Order Report 98, 99
- Work Order Component Check 90
- Work Order Component Issue 92
  - issued to WIP Lots frame 215
  - tracing WIP 215
- Work Order Control 77
- Work Order Cost Report 99
  - co-products/by-products 62
- Work Order Delete/Archive 102
  - co-products/by-products 64
- Work Order Dispatch Report 94, 100
- Work Order History Report 100, 101
  - co-products/by-products 62
- work order ID
  - specifying in an order 151
- Work Order Maintenance 78
  - closing orders 100
  - co-products/by-products 58, 60
  - deleting orders 102
  - master production scheduling (MPS) 258
  - master schedule orders 262
  - releasing orders 89
- Work Order Operation Backflush 75
  - tracing WIP 215
- Work Order Receipt 94, 217
  - co-products/by-products 52, 62, 63
  - WIP Lot Output Queue Issue Data frame 216
  - WIP lot/serial tracing 216
- Work Order Receipt Backflush 91, 95
  - co-products/by-products 48, 52, 62
- Work Order Release/Print 81, 89, 91
  - co-products/by-products 61
- Work Order Reports 99
- Work Order Routing Maintenance 89
  - operation status 107
- Work Order Split 90
- work order status 184
- Work Order Status Change 83
- Work Order Status Report 99, 101
- Work Order WIP Cost Report 99
  - co-products/by-products 62
  - period-end procedures 102
- work orders 73–102
  - bill 85, 88
  - BOM/Formula 85
  - close and receipt date 100
  - co-products/by-products 59
  - deleting 102
  - dispatching 100
  - due dates 86
    - forward vs backward scheduling 87
  - issuing components 91
    - multiple sites 92
  - joint order sets 59
  - key items 90
  - lead times 87
  - life cycle 75
  - manufacturing lead time 86
  - modifying 88
  - MRP planned 282
  - picklists 90
  - receiving items 94
  - release date 86
  - releasing 89
  - routable 81
    - co-product/by-product 61
  - routing 85
    - modifying 89
  - scheduling 85
  - scheduling operations 87
  - splitting 90
  - statuses 82
    - allocated 84
    - batch 83
    - closed 84
    - exploded 84
    - firm planned 83
    - planned 83
    - released 84
  - subcontract operations 93

- tracing WIP 213–219
- types
  - cumulative 81
  - expense 81
  - final assembly 80
  - rework 80
  - scheduled 81
  - standard 79
- user ID recorded 100

## Y

- yield 29
  - enabling operation based 270
  - example 31
  - including in repetitive schedules 118
  - material requirements planning (MRP) 274, 277
  - MRP Control 270
  - work order 85
  - Yield % field 30