



QAD Enterprise Applications
Enterprise Edition

User Guide

QAD Master Data

Items/Sites
Pricing
Product Change Control
Regulatory Attributes
Address Data
Logistics Accounting
Inventory Control
Physical Inventory
Enhanced Reports for .NET UI

70-3172A
QAD Enterprise Applications 2011.1
Enterprise Edition
September 2011

This document contains proprietary information that is protected by copyright and other intellectual property laws. No part of this document may be reproduced, translated, or modified without the prior written consent of QAD Inc. The information contained in this document is subject to change without notice.

QAD Inc. provides this material as is and makes no warranty of any kind, expressed or implied, including, but not limited to, the implied warranties of merchantability and fitness for a particular purpose. QAD Inc. shall not be liable for errors contained herein or for incidental or consequential damages (including lost profits) in connection with the furnishing, performance, or use of this material whether based on warranty, contract, or other legal theory.

QAD and MFG/PRO are registered trademarks of QAD Inc. The QAD logo is a trademark of QAD Inc.

Designations used by other companies to distinguish their products are often claimed as trademarks. In this document, the product names appear in initial capital or all capital letters. Contact the appropriate companies for more information regarding trademarks and registration.

Copyright ©2011 by QAD Inc.

MasterData_UG_v2011_1EE.pdf/mat/mat

QAD Inc.

100 Innovation Place
Santa Barbara, California 93108
Phone (805) 566-6000
<http://www.qad.com>

Contents

What's New?	xi
Chapter 1 Introduction to Master Data	1
Chapter 2 Items/Sites	3
Introduction to Items/Sites	4
Items	4
Codes and Master Comments	6
Cross-Referencing Items	6
Defining Item Data	6
Customer and Supplier Items	15
Item Replacements	15
Internal Part Changeover	19
Product Lines	34
Product Line Maintenance	35
Product Line Accounts	36
Alternate Product Line Accounts	37
Copied Product Lines	38
Copied Product Line Accounts	38
Product Line Replacements	39
Sites	40
Inventory and Accounting	40
Taxes	41
Sites and Enterprise Material Transfer (EMT)	41
Sites and Domains	41
Site Security	42
Creating Sites	42
Creating Site Connection Records	45
Deleting Sites	46
Locations	46
Permanent/Temporary Locations	47
Automatic Locations	48
Location Types	48
Single Item Locations	48
Reserved Locations	48

Physical Address	50
Inventory Status Codes	50
Status Defaults	51
Overissue Policy	51
Restricting Transactions	52
Chapter 3 Pricing	55
Introduction to Pricing	56
Using Best Pricing	58
Planning for Best Pricing	58
Setting Pricing Defaults	59
Setting Up Analysis Codes	60
Setting Up Item Price Break Categories	66
Creating and Maintaining Price Lists	67
Repricing Orders in Sales Order Repricing	81
Repricing in Sales Order Maintenance	83
Understanding Sales Order Maintenance Fields	85
Using List/Discount Table Pricing	86
Price List Types	88
Creating Price Lists	89
Price List Maintenance Programs	90
Generating Price Lists by Item	92
Copying Price Lists	93
Processing List/Discount Prices	96
Price Calculation	98
Displaying Price List Data	99
Changing Price List Classification	99
Chapter 4 Product Change Control.....	103
Introduction to PCC	104
Copied Records	105
PCR/PCO Life Cycle	106
PCR Life Cycle	106
PCO Life Cycle	107
Setting Up PCC	108
Preparing Data for Use with PCC	109
Setting Up PCC Control	110
Defining Groups, Routing Slips, and Change Types	111
Creating PCRs and PCOs	118
Using PCR/PCO Function Maintenance	120
Maintaining Text Records	121
Maintaining Item Records	121

Maintaining Product Structure Records	123
Maintaining Routing Records	126
Maintaining Formula Records	127
Maintaining Process Records	128
Maintaining Item Specifications	128
Maintaining Trailers	129
Reviewing PCO Data	129
Routing PCR and PCOs for Approval	130
Approving PCR and PCOs	131
Rerouting PCOs	131
Detail Approval Maintenance	132
Incorporating PCOs into Production	132
PCO Release and Distribution	132
Incorporation Planning Report	133
Incorporation Selection	134
Incorporation	135
Implementation	135
Closing PCR and PCOs	136
Importing and Exporting PCR and PCOs	136
Setting Up PCC Security	136
Access to PCO Maintenance Detail Functions	137
Restricting Access to Other Functions	137
Chapter 5 Regulatory Attributes	139
Introduction to Regulatory Attributes	140
Site Security	140
Inventory Attributes	140
Batch Control	141
Component Issue Control	141
Lot Control	141
Multi-Lot Inventory Detail	141
Controlled Substances	141
Setting Up Regulatory Attributes	141
Defining Inventory Attributes	143
Why Are Attributes Important?	144
Inventory Attributes Workflow	145
Attribute Descriptions	146
Inventory Attribute Active Field	147
Using Work Order Batch Control	150
Batch Control Workflow	150
Assigning Batch Numbers to Work Orders	150
Changing Inventory Detail Records	151
Using Lot Control	152

Lot Control Workflow	153
Lot Control Relationships	154
Deciding on Lot Control Level	155
Building Lot Master Records	156
Modifying Lot Master Records	157
Automatic Lot Numbering	158
Single Lot per Receipt	160
Supplier Lot Numbers	161
Expired Inventory Transactions	161
Managing Component Issues	162
Component Issue Control	162
Co-product/By-product Component Issue Control	162
Managing Controlled Substances	162
Entering Country Codes	163
Entering Authority Codes	163
Entering Control Numbers for Customers and Sites	164
Entering Control Numbers for Items	164
Entering General License Information	165
Entering Individual License Information	166

Chapter 6 Address Data 169

Introduction to Addresses	170
Addresses Menu	170
Address List Types	171
Setting Up Company Addresses	172
Addresses for Purchase Orders	173
Addresses and GTM	173
Deleting Company Addresses	173
Setting Up Salesperson Addresses	173
Setting Up Customer Data	174
Customer Credit Data	177
Customer Freight Data	178
Other Customer Data	178
Creating Reserved Locations	178
Setting Up Supplier Data	179
Setting Up Supplier Accounts	180
Setting Up Country Code Data	181
Setting Up Delivery Transit Times	182
Setting Up Carriers	183
Setting Up Delivery Docks	184
Setting Up Trailer Codes	184
Setting Up Freight Charges	185
Freight List Maintenance	186

Freight Zone Maintenance	187
Freight Class Maintenance	187
Freight Charges Maintenance	188
Freight Terms Maintenance	188
Blocking Customer/Supplier Transactions	189
Blocked Transactions	190
Defining Blocked Codes	193
Updating Customer or Supplier Records	193
Example Blocked Transaction	194
Chapter 7 Logistics Accounting	195
Introduction to Logistics Accounting	196
Logistics Charges	196
Pending Invoices	198
Logistics Accounting Programs	199
Setting Up Logistics Accounting	202
Setting Up GL Accounts	202
Setting Up NRM Sequence Numbers	203
Setting Up the Control Programs	204
Defining Logistics Charge Codes	206
Defining Detailed Logistics Accounts	208
Calculating Taxes for Logistics Charges	210
Accrual Currency	212
Accruing Inbound Logistics Charges	212
Creating Logistics Cost Elements	213
Updating Item Costs	213
Defining Terms of Trade	214
Assigning Terms of Trade to Suppliers	215
Processing Purchase Orders	216
Tracking Shipments and Paying for Goods-In-Transit	219
Processing Purchase Receipts	221
Accruing Outbound Logistics Charges	223
Updating Freight Terms	223
Processing Orders	224
Processing Shipments	226
Updating Pending Invoices	229
Matching Logistics Charges	230
Deleting and Archiving Logistics Charges	231
Generating Logistics Reports	231
Chapter 8 Inventory Control	233
Introduction to Inventory Control	234

Setting Up Inventory Control	234
Creating Inventory Detail Records	238
Creating Inventory Transactions	238
Transfers	239
Receipts	240
Issues	240
Scrap	240
Shipping Documents	243
Creating Inventory Transaction History	243
Transaction Types	243
Reviewing Transaction History	245
Creating Lot/Serial Number History	246
Performing Cycle Counts	246
ABC Class Code	247
Cycle Counting Procedure	247
Analyzing Obsolete Inventory	248
Obsolete Inventory Analysis Programs	249
Setting Up Obsolete Inventory Analysis	249
Extracting Data for Analysis	260
Analyzing Obsolete Inventory	262
Deleting/Archiving Consumption Data	269
Viewing Obsolete Inventory Analysis Data	270
Creating Inventory Reports	272
Detail Allocation Inventory Report	272
Stock Status Report	272
Reorder Report	272
Item ABC Status Report/Update	272
Inventory Detail Report	272
Inventory Detail by Location	273
Current Surplus Inventory Report	273
Projected Surplus Inventory	273
Inventory Valuation Reports	274
Stock Journal	274
Device History Record Report	274
Item Scrap Report	275
Financial Scrap Report	275
Checking Inventory Availability	275
Chapter 9 Physical Inventory	277
Introduction to Physical Inventory	278
Deleting/Archiving Old Tags	278
Freezing Inventory Balances	278
Creating/Printing Tags	279

Entering Initial Tag Counts	279
Reviewing Results	280
Zeroing/Voiding Unused Tags	280
Updating Inventory Balances	280
Chapter 10 Enhanced Reports for .NET UI	281
Introduction	282
Using Enhanced Reports	282
Running a Report	283
Running Reports Directly From Browsers	284
List of Modified Reports, Browsers, and Inquiries	284
Index	285

Introduction to Master Data

Master data provides basic business information used by other programs. This guide describes the following master data topics:

Items/Sites 3

Items and sites are the foundation of all system modules. The master data in the Item/Sites module define manufacturing and distribution sites, inventory locations, product lines, and items. Customer and supplier item numbers are also defined, with pricing for each. Unit of measure conversions defined here support entry of alternate units of measure in other transactions.

Pricing 55

Pricing data supports automatic pricing by providing price lists during key transactions. Three basic pricing models are used: best pricing model, list/discount pricing for suppliers, and list/discount pricing for customer schedules and RMA receipts.

Product Change Control 103

Product Change Control (PCC) is a flexible information storage tool to control and monitor product changes from inception through implementation. Item engineering data, product structures, routings, formulas, processes, and item specifications can be modified in PCC without affecting the rest of the system. Use PCC to define approval cycles for product changes before the changes are incorporated into production records.

Regulatory Attributes 139

With Regulatory Attributes, companies can manage compliance with international agreements, such as NAFTA and GATT, as well as with government regulations, such as the FDA Current Good Manufacturing Practices.

Address Data 169

Programs in the Addresses module set up data for customers, suppliers, salespersons, carriers, and company addresses as well as setting up freight charges and trailer codes. Shipping groups and documents are also defined in the Addresses module. These records are used exclusively with shipping functions.

Logistics Accounting 195

Logistics Accounting lets companies define and track the individual costs associated with the transportation of goods in and out of company locations. Separate sets of accounts are defined to track the transportation costs related to goods purchased from an external supplier and goods shipped from a company location to a customer or to another company location.

Items/Sites

This chapter discusses two essential elements in product definition: items and product lines. Item records are used to define the actual products that are kept in inventory and/or planned by planning functions. Product lines group items for planning and accounting purposes. In addition, sites, locations, and inventory status codes are introduced.

***Introduction to Items/Sites* 4**

Describes how item/site information supplies a foundation for many other functions.

***Items* 4**

Explains that item records are created for items and products that are stored and/or planned by Material Requirements Planning (MRP) or Distribution Requirements Planning (DRP).

***Product Lines* 34**

Defines product lines and explains how one is used to plan, report, and analyze sales and operations.

***Sites* 40**

Defines site code and explains its use.

***Locations* 46**

Describes how to use Location Maintenance to specify areas within a particular site where inventory is stored.

***Inventory Status Codes* 50**

Describes how to use Inventory Status Code Maintenance to create and modify inventory status codes.

Introduction to Items/Sites

Item/site information supplies a foundation for many other functions. Figure 2.1 illustrates how items and sites are central to other processes.

Fig. 2.1
Items/Sites



This chapter discusses four foundational elements in the system:

Sites. All inventory related functions within the system can be managed by site. A site is a manufacturing or distribution facility that requires separate planning and inventory control. Each site is associated with a domain and a financial entity, which determines the financial impact of inventory movement.

Locations. Within each site, inventory is held in locations. These can be temporary or permanent, and can be assigned rules that govern how inventory in the location can be issued or received.

Items. Items are defined for use throughout the system. The characteristics of an item include inventory data, such as ABC class and shelf life, planning data, such as order policies and lead time, and price and cost data. The same item may have different characteristics at each site.

Product Lines. For planning and reporting purposes, items are grouped by product line.

Items

Item records are created primarily for items and products that are stored in inventory and/or planned by Material Requirements Planning (MRP) or Distribution Requirements Planning (DRP). At this time, items are assigned to product lines, and default data used in inventory control, sales, purchasing, planning, and costing is defined. You can customize costs and other information by site once you set up the initial record.

Figure 2.2 shows the major elements that are implemented during product definition, in the order they are set up. Only product lines and items are mandatory. Usage of the other elements varies based on your business requirements and is described in other chapters.

Fig. 2.2
Product Definition Flow

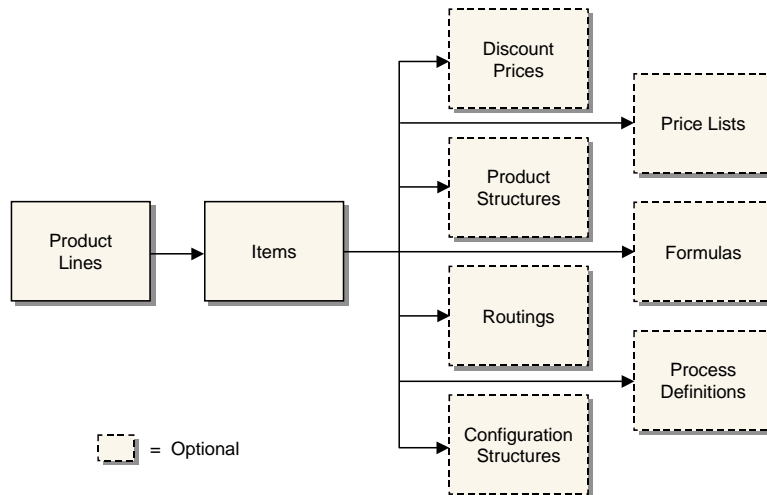

Item data is divided into four categories that roughly parallel how companies typically divide up the maintenance responsibility. Table 2.1 lists the data types and responsible departments.

Table 2.1
Item Data

Data Type	Responsible Department
General Data	Product Engineering or Research and Development
Inventory Data	Inventory Control or Materials Management
Planning Data	Material Planning
Cost Data	Cost Accounting

Because some information serves multiple programs, a field that is the responsibility of one particular organization within your company may not be where you expect it. For example, the default list price for a product might be determined by the sales department, but this field is considered cost data, normally maintained by accounting.

To support this potential division of responsibilities, there are two ways to define item master data:

- From Item Master Maintenance (1.4.1), you can enter all item data. This is the only program that can be used to create new item numbers. This method is the most convenient.
- From separate programs, you can create the item record (1.4.3), then enter planning data (1.4.7), inventory data (1.4.5), and cost data (1.4.9). This method offers the most security, because access to the individual programs can be restricted with menu security.

Note If you are using Service/Support Management, and Service Data in Item Master is Yes in Service Management Control (11.24), you can also update service item attributes in Item Master Maintenance.

If your company manages the same items at multiple sites, you can control, plan, and cost items separately for each site. Data can be differentiated by site using the item-site data programs (1.4.16, 1.4.17, 1.4.18). Programs that process an item at a particular site first look for item data specific for the site. If none is found, the system uses the item master record.

Internally, the system requires one and only one item master record for each item. Item-site data is optional.

Codes and Master Comments

A number of different codes such as item group and item type provide a short, convenient way to categorize and identify items. However, more extensive information related to an item may be needed.

Example Product Engineering maintains information concerning the implementation of engineering change orders for an item. Purchasing tracks specific supplier requirements and Quality Engineering stores inspection-related text.

These requirements can be met by using Master Comment Maintenance (1.12) to record comments about an item. Each master comment can have up to 99 pages of text. Master comments are identified by reference, type, and language codes. To create master comments for an item, enter the item number as the reference code.

Use the Type field to identify different master comment records for the same item number. For example, the type codes PE, PO, and QE can be used for Product Engineering, Purchasing, and Quality Engineering. To review all the master comments entered for an item, print the Item Master Comments Report (1.5.12).

Master comments do more than store and organize textual information for an item. They can also be copied into documents such as purchase orders, sales quotations, and sales orders when the item is added to the document.

Cross-Referencing Items

You may need to create relationships between item numbers for a variety of reasons. You can use functions on the Items/Sites menu to manage these relationships.

- A customer or supplier may prefer to order using their own item number or an industry standard number rather than the one your company uses. See “Customer and Supplier Items” on page 15.
- Items requested on sales orders may not be available for customer delivery for a variety of reasons. The item may be obsolete and be replaced by a different item. It may now be sold as part of another item that includes it, known as an up-sell item. Or you may want to encourage the sale of a complementary product, known as a cross-sell item. See “Item Replacements” on page 15.

Defining Item Data

You can use Item Master Maintenance (1.4.1) to define all of the attributes of an item.

General Item Data

Every item has some relatively static information that describes its general characteristics, regardless of how it is used. This includes the item's description, product line, unit of measure, drawing, revision, status, and so on.

Any general data you set up for an item must be valid for all sites in the system, since this data cannot be defined per site. If general item data for an item varies by site, you must set up the item with different item numbers.

Fig. 2.3
Item Master Maintenance (1.4.1), Item Data

The screenshot shows a software window titled "Item Master Maintenance" with a sub-tab "Item Data". The "Item" section contains: Item Number: FL4800, Description: Electronic Switch, and Unit of Measure: EA. The "Item Data" section contains: Prod Line: SSM, Item Type: , Drawing: , Added: 04/18/2005, Status: AC, Revision: , Design Group: , Group: , Drawing Loc: , Size: , Promo Group: , and Price Break Category: .

The item number, description, product line, and unit of measure (UM) are the most visible and most important engineering fields.

The item number is the index for item data. Whenever you enter a number in an Item field, it is validated against numbers in the item master. The fields for unit of measure, group, type, and status permit virtually any combination of characters. Most of these fields are validated with generalized codes, and lookup browses can be set up.

See *User Guide: QAD System Administration* for details on generalized codes.

Important It is important for purchase orders and for the operation of the Product Change Control module that the engineering revision level for an item is the same in Item Master Maintenance and Item-Site Planning Maintenance. Use the Item Revision No Variation Report (1.5.19) to highlight any revision variations for review and correction.

Item Number and Description

Most companies have not escaped controversy when determining conventions for item numbering and item descriptions. Proponents of significant, semi-significant, and nonsignificant item numbering schemes argue the advantages and disadvantages of coding information into an item number.

For multi-national organizations that have users with diverse languages, defining items using only numeric characters can be an important requirement. If user languages are not based on the same code page, some characters may not display correctly.

Any numbering scheme is possible. Since you can access lookups that can be searched by item number or description, significant numbers are not critical.

Item Unit of Measure

The item unit of measure is used for inventory balances, product structures, manufacturing orders, planning, and reporting. Values can be defined with generalized codes.

Different areas of a company may handle an item using different units of measure. For example, an item may be moved in pallets but sold by the box. For these cases, set up alternate units of measure and conversion factors in Unit of Measure Maintenance (1.13).

When items are handled in different units of measure on purchase orders, sales orders, and inventory transactions, the system automatically converts the quantities from an alternate unit of measure to the item unit of measure using the predefined conversion factors. In most cases, either unit may be entered on transactions.

The formula for alternate unit of measure is:

$$\text{Standard UM} * \text{Conversion} = \text{Alternate UM}$$

Grouping Fields

If grouping items by product line does not satisfy the planning and reporting requirements of all company departments, the item type and group fields can also be used to group items. Both fields are used in the planning and sales modules. The item type is also used for product costing functions and cycle count reporting.

Design groups are used in the Product Change Control module to determine who is responsible for changes affecting the item.

Item Status Code

Use Item Status Code Maintenance (1.1.5) to define status codes to associate with items in Item Master Maintenance or Item Data Maintenance. Status codes indicate where an item is in its life cycle from planning through design, production, and obsolescence. For example, you can set up a status code of AC to show that an item is actively manufactured and sold, and one of OB to identify obsolete items.

Use item status codes to restrict which transactions can occur for a particular item. When you process an item transaction, the system checks the item's status code to verify that the transaction is not restricted. If it is, an error message displays and you cannot proceed.

You also can use item status codes to select records in some reports and other functions. For example, when you are updating ABC code rankings and calculations using Item ABC Status Report/Update (1.5.9 or 3.6.3), you can enter a comma-separated list of item status codes to be excluded. The function does not process items associated with specified codes.

Item Inventory Data

Inventory control is responsible for the security, movement, accuracy, and, in some cases, the allocation of inventory. Every item has inventory control information associated with it. The system uses this information to track and control the movement of the item. For example, if an item has an expiration date, you cannot issue the item after that date.

Most of the fields you specify in this frame default to the same fields in Item-Site Inventory Data Maintenance (1.4.16) when you set up a record for a specific site. Article number is only defined at the item level. Lot groups are already defined by site when they are set up in Lot Group Maintenance (1.22.13).

Fig. 2.4
Item Master Maintenance (1.4.1), Item Inventory Data

Item Inventory Data		
ABC Class:	Average Interval: 90	
Lot/Serial Control: S	Cycle Count Interval: 120	
Site: FL1000	Shelf Life:	
Location: 100	Allocate Single Lot: <input type="checkbox"/>	
Location Type:	Key Item: <input type="checkbox"/>	
Auto Lot Numbers: <input type="checkbox"/>	PO Receipt Status:	Active: <input type="checkbox"/>
Lot Group:	WO Receipt Status:	Active: <input type="checkbox"/>
Article Number:	Memo Order Type:	

The following briefly explains how inventory control fields are used.

ABC Class. This code classifies items by level of importance, such as dollar value, with class A being the most important. The system uses the ABC class code with cycle counting. You can add the code directly or leave it blank. If left blank, you can have the system calculate an item's ABC class code by running the Item ABC Status Report/Update (1.5.9 or 3.6.3). See "Item ABC Status Report/Update" on page 272.

Lot/Serial Control. The value of Lot/Serial Control for the item determines if a lot or serial number is required.

Blank: Lot/serial numbers are not required, although they can be recorded as needed.

L: Lot numbers are required for this item. During issues and receipts, a lot number must be entered. The lot number applies to the entire transaction quantity entered.

S: Serial numbers are required for this item. During issues and receipts, a unique serial number must be entered for each item. For example, if you receive 10, you must enter 10 serial numbers.

The system maintains complete lot/serial number traceability. The Lot Actual Bill Inquiry (3.22.3) lists all the lot/serial numbers of components and raw materials used to make a given lot/serial number. Lot Where-Used Inquiry lists all the places that an individual lot/serial number was used, all the way to the end customer.

For manufactured items, lot numbers can optionally be assigned by the system by setting Automatic Lot Numbers to Yes. When the item is received into inventory using a work order receipt function, the lot number is set to the work order lot ID.

If you are using the Regulatory Attributes module (1.22), stricter levels of lot and serial control are available. You can also generate lot numbers based on a pattern specified in the Lot Group field.

See "Assigning Lot Groups to Items" on page 158.

You cannot modify this value from blank to S or L if a quantity of the item already exists in inventory.

Site. Specify the site where you normally manufacture or store the item. The site defaults from Inventory Control (3.24), but can be overridden.

Location. Enter an optional location code indicating the physical location where this item is normally stored. See "Locations" on page 46 for details.

The value you enter is the default for all sites. Since locations often vary by site, set up site-specific values in Item-Site Inventory Data Maintenance (1.4.16).

Note Default locations for sales transactions can also be defined by the customer in Reserved Location Maintenance (2.1.9.1). Consigned inventory uses the default locations defined in Ship-To/Item Controls Maintenance (7.18.1).

Repetitive inventory backflush uses default item or item-site locations only when the work center where the backflush occurs is not itself specified as a location.

Assigned item locations are particularly useful when you always store an item in the same place, since they minimize data entry and prevent errors.

Location Type. Enter a code identifying the type of location where this item is stored.

The value you enter is the default for all sites. Set up site-specific values in Item-Site Inventory Data Maintenance (1.4.16).

A type code can be assigned to each location in Location Maintenance (1.1.18). When an item is received, transferred, or counted using a cycle count or tag count, the system verifies that the location type matches the location type associated with the item. If not, an error displays and the transaction cannot be processed.

Use type codes for items with special storage requirements, such as temperature or humidity. You can describe the exact requirements using master comments associated with the item.

Automatic Lot Numbers. This field determines whether the system automatically assigns lot numbers to items with Lot/Serial Control set to Lot. It has no effect for other items.

The value you enter is the default for all sites. Set up site-specific values in Item-Site Inventory Data Maintenance (1.4.16).

The following programs can assign automatic lot numbers:

- Purchase Order Receipts (5.13.1)
- Work Order Receipt (16.11)
- Work Order Receipt Backflush (16.12)
- Repetitive Labor Transaction (18.14)
- Work Order Operation Backflush (16.19)

How lot numbers are generated when Automatic Lot Numbers is Yes depends on whether you specify a lot group. Lot groups are only available if you are using the Regulatory Attributes module (1.22).

- If you enter a value in the Lot Group field, number format is determined by the rules specified in Lot Group Maintenance (1.22.13).
- If Lot Group is blank, work orders use the work order ID as the lot number. Automatic lot numbers are not assigned in purchase orders.

See “Assigning Lot Groups to Items” on page 158 for information on lot groups.

Average Interval. Specify the number of calendar days used as the averaging interval in ABC computations.

Cycle Count Interval. Specify the number of calendar days between cycle counting this item.

Shelf Life. Enter the number of calendar days that this item can be held in inventory before it becomes unusable. Shelf life is typically defined for items that spoil or degrade over time.

You can use shelf life to set the expiration date for inventory. Inventory that has expired does not appear on picklists as a quantity to be picked. If you try to ship or issue expired inventory, an error message displays and you cannot continue.

The system calculates an expiration date when an item is received into inventory by adding the number of days specified for shelf life to the receipt date. You can change expiration date using:

- Inventory Detail Maintenance (3.1.1)
- Detail Maintenance by Item/Lot (3.1.2)
- If you are using the Regulatory Attributes module, Multi-Lot Inventory Detail Update (1.22.19)

When a lot is recertified, a new expiration date can be assigned.

You can impose additional restrictions by using the Issue Days field in Inventory Control (3.24). If you set the number of days to 5, you cannot ship or issue expired inventory or inventory that will expire in the next 5 days.

Allocate Single Lot. This field indicates whether the system should always fill sales orders and work orders from a single lot of this item. If Yes, you can manually allocate orders from more than one lot using Sales Order Manual Allocations (7.1.6) or Work Order Bill Maintenance (16.13.1), but the system displays a warning message.

Key Item. Enter Yes if you do not want to start an order when an insufficient quantity of this item exists. Otherwise, enter No.

You cannot release a work order or print a picklist when a sufficient quantity on hand of a key item does not exist. An error message displays. You can adjust the order quantity manually to ensure that you can complete the order.

Key items are typically difficult to obtain. They may have long lead times or may be in short supply. Only a few items should be designated as key items. For example, glass is a key item for a window manufacturer. When enough glass is not available to fill an order, the order cannot be started.

PO Receipt Status. Specify a default inventory status for the item when received on a purchase order. This field is optional. If not specified, the status of the location or site is used as a default. See “Inventory Status Codes” on page 50.

WO Receipt Status. Specify a default inventory status for the item when received on a work order. This field is optional. If not specified, the status of the location or site is used as a default.

Memo Order Type. Leave blank to indicate that this is not an expensed memo item.

Enter a type code to indicate that this item is an expensed memo type item. These items have no effect on inventory or MRP when they are placed on an order. Any entry other than blank implies an expensed item.

When you place items on an order, this value defaults to the line item Type field in the following sales- and purchase-related programs:

- Sales Order Maintenance (7.1.1), Sales Quote Maintenance (7.12.1), RMA Maintenance (11.7.1.1), and Customer Scheduled Order Maintenance (7.3.13)
- Purchase Order Maintenance (5.7), Requisition Maintenance (5.2.3), and Supplier Scheduled Order Maintenance (5.5.1.13)

The value you enter is validated against values defined in Generalized Codes Maintenance (36.2.13) for field name `pt_memo_type`. If no generalized codes are set up for this field, you can enter any value.

Note Do not set up generalized codes for values that already have a specific meaning. For example, values such as B (for blanket), S (for subcontract), and R (for RTS) invoke unique processing that may override or conflict with memo type order processing.

Item Shipping Data

The shipping department uses item shipping data to determine freight charges. For example, freight charge calculations use the item's shipping weight to determine freight costs.

See “Setting Up Freight Charges” on page 185.

Fig. 2.5
Item Master Maintenance (1.4.1), Item Shipping Data

Item Shipping Data	
Corp Comm Code:	<input type="text"/>
Ship Weight:	<input type="text" value="0.00"/>
Freight Class:	<input type="text"/>
Net Weight:	<input type="text" value="0.00"/>
Volume:	<input type="text" value="0.00"/>

In some business environments, it is a common practice to use commodity codes to group items for internal business needs. For example, all suppliers providing a certain kind of commodity—represented by a commodity code—may be rated together, regardless of the particular item.

Note If you are using the Supplier Performance module, performance can be monitored based on commodity codes. See *User Guide: QAD Purchasing*.

Create valid commodity codes and associate groups of items with them in Commodity Code Maintenance (1.4.19). The associated code then displays in Item Master Maintenance and can be modified if needed.

Note Corporate commodity codes are distinct from the commodity codes used to classify goods for Intrastat reporting purposes. These are set up with Intrastat Commodity Code Maintenance (29.22.3) in the Intrastat module. See *User Guide: QAD Intrastat* for details.

Planning Data

The material planning department uses item planning data to determine how and when to replenish inventory. This data affects MRP, purchasing, manufacturing (work orders, repetitive schedules, and master scheduling), configured products, and costing. Most of the fields are used in material requirements planning (MRP).

For details about MRP, see *User Guide: QAD Manufacturing*.

Fig. 2.6
Item Master Maintenance (1.4.1), Item Planning Data

The Pur/Mfg (purchase/manufacture) code determines how items are planned, costs are calculated, and cumulative lead times are calculated. This code can be:

- Purchased: obtained from suppliers
- Manufactured: produced internally, typically with work orders
- Line: produced internally, typically on a production line
- Flow: produced internally, typically on a flow production line
- Routable: produced internally
- Distribution: obtained from distribution sites
- Configured: configured to customer order and produced internally
- Family: a special type of item used for operations planning

Note The system assumes items with a blank Pur/Mfg code are manufactured. If you are viewing items on a production line in the .NET UI Master Scheduling Workbenches, you must set this field to L to view the item.

Specifying an ATP horizon for an individual item in Item Master Maintenance or Item-Site Planning Maintenance overrides the Sales Order Control value.

Replenishment Method. Specify the method to replenish inventory. The default is Orders.

Kanban: Entering kanban creates a kanban record for the item in kanban. Kanban is a method of just-in-time (JIT) production that uses standard containers or lot sizes with a single card attached to each. It is a pull system in which work centers use a card to signal that items are to be withdrawn from supply sources. The kanban system defines a communication signal or card indicating that items need replenishment.

Orders: MRP uses order due dates to determine when quantities will be available to replenish inventory.

Purchase/Manufacture: Inventory is replenished by purchasing it from suppliers or manufacturing it internally, typically with work or production orders.

DRP: Inventory is replenished through distributed requirements planning (DRP) intersite requests, which balance supply and demand among sites.

Family: Inventory is replenished through family-level items. Components of the family item are special items that can be any type: manufactured, configured, or another family item.

Routable: Inventory is replenished from items produced internally.

Configured: Inventory is replenished through products that are configured to customer order and produced internally. These are indicated by a Pur/Mfg code of Configured in Item Master Maintenance.

Purchased: Inventory is replenished through purchased items, driven by purchase orders.

Manufactured: Inventory is replenished through manufactured items.

Line Manufactured: Inventory is produced internally, typically on a production line.

Item Cost Data

The item cost data is divided into three sections:

- Price and tax data
- General ledger (GL) cost
- Current cost

Price

Price and costs are entered in base currency specified in Domain/Account Control. The item master price is the default list price in sales transactions, if price lists are not being used. You can only assign one list price directly to an item.

See Chapter 3, “Pricing,” for details on using price lists.

The taxable status and tax code default from the product line and are used in the Purchasing, Sales Orders/Invoices, and Customer Services modules.

GL and Current Costs

The item GL costs are the standard costs used for GL transactions. Both the GL costs and current costs are the costs for the item at the site specified in the inventory data section.

In turn, each of these costs has five cost categories: material, labor, burden, overhead, and subcontract. Burden is sometimes known as variable burden or variable overhead. Overhead is known as fixed burden or fixed overhead. Use Item-Site Cost Maintenance (1.4.18) to update the GL and current costs for a particular site.

Both the GL and current costs can be updated automatically during routing and product structure roll ups by using item cost utilities in the Item Data Menu (1.4) or by using cost simulation programs in the Cost Management module.

These programs are discussed in *User Guide: QAD Costing*.

Customer and Supplier Items

A customer may prefer to order using their own item number or an industry standard number rather than the one your company uses.

Example Contractors may be required to order with a government procurement code instead of your item number.

Use Customer Item Maintenance (1.16) to set up a cross-reference between your item numbers and those used by a customer. A customer may have more than one number that references a single internal item number. If so, you can set up multiple relationships.

When a customer item number is specified on a sales order, the system accesses the price, description, and other information associated with your item number. Both item numbers appear on all sales and shipping paperwork.

In scheduled orders, you can specify a customer item number in the Customer Ref field as part of the set of values that identifies a scheduled order line. This lets you set up multiple lines for the same internal item number, ship-from site, ship-to address, and PO number. To require valid customer items in the Customer Ref field, set Customer Ref is Customer Item to Yes in Customer Schedules Control (7.3.24) or Container/Shipper Control (7.9.24).

Customer item numbers appear in reports, inquiries, and browses and under a Customer Ref heading in programs that manage scheduled orders and shipper data.

You can also use Customer Item Maintenance to set up a cross-reference between internal numbering systems. For example, your sales department may have catalog numbers that differ from the item numbers used by manufacturing. To set up an internal cross-reference, leave the Customer/Ship-to field blank.

The same need to cross-reference numbers may exist for your suppliers. Use Supplier Item Maintenance to create a cross-reference between your suppliers' numbers and your item numbers, as well as track the quoted price and lead time. Specify supplier item numbers in Blanket Order Maintenance, Purchase Order Maintenance, and Supplier Scheduled Order Maintenance. Both your number and the supplier number displays on reports, as well as in Purchase Order Receipts (5.13.1).

See *User Guide: QAD Scheduled Order Management*.

Item Replacements

When taking a customer order, requested items may not be available for customer delivery. To complete the customer order, you can substitute the requested item with one of the following:

- *Replacement items* replace the internally discontinued requested item with an equivalent item under a different number. Define these in Item Replacement Maintenance (1.23.1).
- *Up-sell items* have a higher assembly level in the bill of materials (BOM) than the requested item. Define these in Item Up-Sell Maintenance (1.23.5).
- In some instances, you may use the order-entry process as an opportunity to *cross-sell* complementary products. Cross-sell items are not replacement items for the requested items. They are sold in addition to the requested item to increase revenue or as a promotion for an item. Define this type of relationship in Item Cross-Sell Maintenance (1.23.7).

When these relationships have been defined, users are prompted in order-entry functions to select an appropriate replacement.

Setting Up Replacement Items

Use Item Replacement Control (1.23.24) to set system defaults for item replacement, up-sell, or cross-sell functions.

Note Before you specify the item replacement, you must define both the original item and the item that replaces it in Item Master Maintenance (1.4.1). If you delete an item defined in Item Master Maintenance, the system automatically deletes it in item replacement functions.

Fig. 2.7
Item Replacement Control (1.23.24)

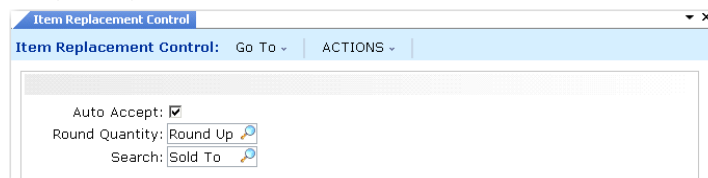

Auto Accept. Indicate whether the replacement items, up-sell items, or cross-sell items should be added to an order without prompting for confirmation.

No (the default): When you enter an order or quote for the original item, you are prompted to confirm that the system replace the requested item with a replacement or up-sell item or that the system add cross-sell items to the order in addition to the requested item.

For item replacements, the system prompts you to confirm replacement after you enter the original item quantity at the line entry level. If you enter Yes at the prompt, a message displays indicating that the item is being replaced, and the order process continues.

For up-sell items, the system prompts for confirmation after you select an item from the Up-Sell Item frame.

For cross-sell items, the system prompts for confirmation to add the cross-sell item to the order after you select one or more cross-sell items from the Cross-Sell Item frame. You are prompted to confirm once, even though you may have selected multiple cross-sell items.

Yes: You can replace the item with a replacement item or up-sell item or add one or more cross-sell items without confirmation.

- For replacement items, the system replaces automatically.
- For up-sell items, automatic replacement occurs after you select an up-sell item from the Up-Sell Item frame.
- For cross-sell items, automatic replacement occurs after you select one or more items from the Cross-Sell Item frame.

This value defaults to the Auto Accept field in Item Replacement Maintenance, Item Up-Sell Maintenance, and Item Cross-Sell Maintenance.

Round Quantity. Indicate the rounding method to use when non-whole number replacement item, up-sell item, or cross-sell item quantities are encountered.

Round Up (the default): The system rounds the item quantity up to the next whole number. For example, 3.3 is rounded up to 4.

Round Dn: The system rounds the item quantity down to the whole number. For example, 3.7 rounds down to 3. Any quantity less than 1 is rounded down to 0; however, this causes the system to report an error, and you must reenter the order or quote quantity.

None: The decimal quantity calculated by the system is the quantity of the new item used on the order or quote.

Mnemonics for this field are defined in Language Detail Maintenance (36.4.2).

This value defaults to the Round Quantity field in Item Replacement Maintenance, Item Up-Sell Maintenance, and Item Cross-Sell Maintenance.

Search By. Enter either Sold To or Ship To as the search method to use when searching for replacement item records during order entry.

Sold To (the default): The system searches for an item replacement record that matches the order based on the following order:

1. Site, customer (sold-to), item, and effective date
2. Customer (sold-to), item, and effective date
3. Item and effective date

Ship To: Use this setting when you predefine ship-to addresses as customers. The system searches for an item replacement record that matches the order or quote based on the following search order:

1. Site, customer (ship-to), item, and effective date
2. Customer (ship-to), item, and effective date
3. Item

Defining Replacement Items

Use Item Replacement Maintenance (1.23.1) to define replacement items for items currently being used in the system. Replacement items are defined by site, customer, and effective date, or any combination of these.

The most efficient way to create generic replacement records for an item is to leave the Customer and Site fields blank in the header. Leave the Include field set at Yes (the default) for generic item replacement for all customers and sites.

If you have one or more customers or sites that still want the original item, you can easily create an exception record for them. Specify the Site or Customer in the header, but set Include to No. This tells the system to exclude this record from the generic replacement you already defined.

You can define other specific item replacement records by specifying any combination of site, customer, and effective date. Include should always be Yes, unless you specify an exception to these specific replacements. In this case, set Include to No.

Fig. 2.8
Item Replacement Maintenance (1.23.1)

The screenshot shows a software window titled "Item Replacement Maintenance". At the top, there is a header bar with "Item Replacement Maintenance: Go To" and "ACTIONS". Below the header, there are three input fields: "Item Number:", "Site:", and "Customer:", each with a magnifying glass icon. Underneath these fields, there are several other fields: "Effective Date:", "Include:" with a checkbox, "Quantity:", "Replacement Item:", "Rep Quantity:", "PCO Number:", "Comment:" with a checkbox, "Auto Accept:" with a checkbox, and "Round Quantity:".

Item Number. Enter the item number for which you are defining a replacement item. Items must be predefined in Item Master Maintenance (1.4.1). You cannot specify:

- An item as its own replacement
- A customer item

Site. Optionally, enter the site where this item replacement record should be active. Leave blank to indicate the item should be replaced at all sites.

Customer. Optionally, enter the customer for whom this item should be replaced. Leave blank to indicate the system should replace on orders created for any customer. Customers can be ship-to or sold-to addresses. Customers must be predefined in Customer Create (27.20.1.1).

Effective Date. Enter the date this record should be activated. This determines when the system automatically begins to replace the associated item. Effective Date cannot be blank.

Include. Use this field to make a record active.

This field is useful when you have a generic item replacement for all customers or all sites, but you want to exclude a particular customer or site. You can specify the unique customer or site in the header then set this field to No to exclude this record from item replacement that occurs for all other customers or sites.

No: This record is not active.

Yes (the default): This record is active and should be used for replacement.

Quantity. Enter the quantity of the item being replaced.

Replacement Item. Enter a valid item number defined in Item Master Maintenance to use as the replacement item.

Rep Quantity. Enter the quantity of the replacement item. The replacement quantity cannot be 0.

PCO Number. Optionally, enter the number of the product change order (PCO) associated with the change that requires this item to be replaced. This field is reference only if you are using the Product Change Control (PCC) module. If you are not using the PCC module, enter any tracking number that is meaningful in your system. See Chapter 4, "Product Change Control," on page 103.

Comments. Specify Yes to enter comments and have the system copy and display those comments when you enter an order or quote for the replaced item; otherwise, enter No.

Auto Accept. This value defaults from the corresponding field in Item Replacement Control (1.23.24). See page 16.

Round Quantity. This value defaults from the corresponding field in Item Replacement Control. See page 16.

Defining Up-Sell Items

Use Item Up-Sell Maintenance (1.23.5) to define replacement items or assemblies that are an upgrade or a level above the requested item in the item's product structure.

Up-sell items are used only when the requested item is not available during order entry. If the original item is available to meet the order requirement, the system will not replace the original item even if you define an up-sell item for it.

Up-sell items are defined by site, customer, and effective date, or any combination of these. You can define multiple up-sell items for a single item; however, only one up-sell item can be the default replacement for the requested item.

Header fields are similar to those described for Item Replacement Maintenance; however, for up-sell item records, the original item cannot be previously defined as an up-sell item replacement.

See page 17.

Defining Cross-Sell Items

Use Item Cross-Sell Maintenance (1.23.7) to define items you offer to the customer in addition to the item being ordered. Cross-sell items are typically complementary products to the item requested; however, they do not replace the item being ordered. Cross-sell items are defined by site, customer, and effective date, or any combination of these.

Example A customer orders 1000 batteries for the cameras his company manufactures. The camera batteries have a cross-sell battery charger defined for them. During order creation, the order entry clerk enters the batteries, then views battery charger data that displays after the battery line is entered. The order entry clerk suggests to the customer that he may want to offer his customers the battery charger along with the batteries.

You can define multiple cross-sell items for a single item as well as multiple default cross-sell items for an item.

Header fields are similar to those described for Item Replacement Maintenance; see page 17.

Internal Part Changeover

Internal part changeover functionality lets you plan, ship, and invoice while phasing in new internal part numbers yet keeping customer part numbers the same. Since all of this happens automatically, the need to manually change orders, plans, and schedules is eliminated. The system automatically manages the change from one internal part number to another, so your purchase order operations continue without disruption.

Note You can use internal part changeover functionality even when customer item numbers are not used. So, an item replacement schedule that consists of internal parts does not require an associated customer item before internal part changeover features can function properly.

The system provides inventory visibility for older, internal parts that have been replaced by newer, improved parts. This allows a company to effectively use up existing inventory before shipping the latest part.

Since you can set effective dates or quantities that stipulate a change to replacement part numbers, you can effectively plan and anticipate internal part number changes. Internal part changeover functionality ensures that required ship schedules are not created for expired customer scheduled order lines.

Features

Internal part changeover functionality uses the system's item replacement functionality to provide the system with an automated way of moving seamlessly from one internal part to another using item replacement effective dates and effective cumulative shipped quantities.

Note Item Replacement programs are in menu 1.23; see “Item Replacements” on page 15.

The effective dates stipulate when a new internal part number replaces another part number on order documents. You can also set cumulative shipped quantity levels to stipulate when an internal number is replaced. Both methods let you plan the phase-in of new internal part numbers. Internal part changeover features let you:

- Map incoming customer demand requirements to the correct internal part number based on item replacement effective dates or cumulative shipped quantities.
- Manage the cumulative required and shipped quantities correctly when switching to new internal part numbers.
- Know when there is excess inventory when internal part numbers change.
- Report on:
 - Contract activity for the customer part number
 - Full visibility of the contract history for both the past and current active line items for a customer part number
 - Available inventory for each item, including remaining inventory that exists for item numbers being replaced
- Use system-created picklists that display remaining inventory of old item numbers.
- For an RSS, report on:
 - Item replacement details and full item replacement schedule
 - An RSS split, for which order lines, and the cause of the split (date or quantity)
 - Warnings for requirements that fall outside the effective date range for the order line or that exceed the end effective quantity

The following topics discuss areas within the system that operate with internal part changeover functionality.

Customer Scheduled Orders

The following topics discuss enhancements made to customer scheduled order line data when using internal part changeover functions.

Contract Lines

When entering order lines, the system displays a frame that lets you search through the order lines on a scheduled order by specifying an item number or customer item number. For existing numbers, the system displays contract lines that match the selection criteria. You can select a line to edit, and that line's information is populated in the next frame. You can also leave both fields blank to display the next frame, which prompts you to enter item number, customer reference, model year, and so on with those fields left blank.

Customer Item/Item Replacement Creation

When you create an order line using an item number that does not have a customer item cross-reference, the system now prompts you to create one from within Customer Scheduled Order Maintenance (7.3.13). The system displays Customer Item Maintenance frames, including the Item Replacement Details frame. You can create a customer item cross-reference to the item or an item replacement for the item.

Master Lines

When scheduled order lines have the same domain, ship-from, ship-to, customer part number, PO number, customer reference, and model year, and the internal items on the order lines all belong to the same item replacement schedule, the system groups them into an order line set. The first line of the set is the master line. An *order line set* is a group of order lines that the system treats as a single order line because each item/line is a replacement as defined by the item replacement schedule and the values in the ship-from, ship-to, customer item, PO, customer reference and model year fields.

The master line effectively controls all non-master lines in the order line set. Required Ship Schedule (RSS) parameters specified on the master line are filtered down to the non-master lines, and start/end effective dates set at the master line also apply to the non-master lines.

All planning and shipping schedules are built using the master line. You can create or update an RSS for a master or a non-master line.

Active Start/End Effective Dates

Customer scheduled order lines have active start and end dates that let you control planning and shipping for the order line. When you create an RSS, either manually or using RSS Update, the system does not add schedule requirements with dates after the end effective date.

On the RSS output report, the system lists requirements as rejected when the order line is expired. When shipping items, the system displays a warning to alert you that the order line is no longer effective when you attempt to ship requirements past the end effective date.

Cumulative End Effective Quantity

The End Eff Qty field for order line data lets you enter the end effective cumulative shipped quantity for the master line and for all orders in the line set. When creating an RSS, the system does not allocate the portion of the requirement that exceeds the end effective quantity. For example, if the requirement is for 100 and the end effective quantity is for 75, the system creates the RSS for 75 and displays the original requirement quantity and a message indicating that the quantity was adjusted.

On the RSS output report, the system lists requirements as rejected when the requirement quantity exceeds the end effective cumulative shipped quantity. When shipping, the system displays a warning to alert you that the order line is no longer effective due to cumulative quantity and prompts you to change the quantity.

Item Replacements

You can add multiple levels of automatic item replacement in Item Replacement Maintenance (1.23.1). For example, B2 can replace B1, and B3 can replace B2, and when a customer orders B1 and B3 is the effective part, B1 is replaced with B3. Item Replacement Maintenance lets you specify a ship-to address or a customer address as part of the item replacement record. For more information on item replacement, see “Item Replacements” on page 15.

Customer Items

Customer Item Maintenance (1.16) lets you define multiple internal part numbers for a single customer item number using the Item Replacement Details frame.

Setting Up Internal Part Changeover

Before you can take full advantage of internal part changeover functionality, you must set up the following:

- Create a Customer Part Number Cross-Reference.
- Create an Item Replacement Record.
- Update Customer Scheduled Orders.
- Update Customer Plan/Ship Schedules.
- Create an RSS for Customer Schedules.

Create a Customer Part Number Cross-Reference

Use Customer Item Maintenance (1.16) to set up a relationship between a single customer item and one or more internal part numbers.

- 1 After you specify the customer/ship-to, specify the customer item. With the item replacement functionality, you must create customer item maintenance records for every ship-to/dock to which a customer item may be shipped.
- 2 In the Item field, enter the internal part number to associate with the customer item, then press Go.

The system displays the Internal Items frame, which lists replacement item numbers that are associated with the internal item number. The frame also indicates the site, customer, effective date, changeover quantities, and whether the item replacement is included.

- 3 Select an item replacement from the list to edit, or press Go to enter a new internal part number to associate with the customer item number.
- 4 Enter or edit the site, internal item number, replacement item, effective date, changeover quantity, and PCO.
- 5 Indicate whether to make the cross-reference active by setting Include to Yes.

Note Cust Cum Shipped is display only; it is calculated by totaling the cumulative shipped quantity for the item using customer, ship-to, and/or site data.

The following figure depicts Customer Item Maintenance frames and fields of importance when specifying multiple internal part numbers that correspond to a single customer item number.

Fig. 2.9
Customer Item Maintenance (1.16)

Customer Item Maintenance

Go To Actions Copy Print Preview

Cust/Ship: 002
Customer Item: 1-bb

Item: 1-BB

Site	Customer	Replacement Item	Eff Date	Change Over Qty	Inc
	002	1-bb-1	2/2/2009	0.0	<input type="checkbox"/>

Replacement Details

Site: Item: 1-bb
 Replacement Item: 1-bb-1 Effective Date: 2/2/2009
 Change Over Qty: 0.0 Cust Cum Shipped: 36.00
 PCO: Include

Create an Item Replacement Record

Before you can use internal part changeover functionally, you must have an existing item replacement record. Use Item Replacement Maintenance (1.23.1) to create the record.

Note Before you create the item replacement, you must define both the original item and the item that replaces it in Item Master Maintenance (1.4.1). If you delete an item defined in Item Master Maintenance, the system automatically deletes it in item replacement functions.

You can define the replacement item by site, customer, effective date, item and replacement item, or any combination of these.

For internal part changeover functions, use the following procedure:

- 1 Enter the original item to be replaced as the internal part number. Enter the internal part number in the Item Number field.
- 2 Enter the site.
- 3 Enter the customer/ship-to in the Customer field.

- 4 Enter an effective date for the item replacement in the Effective Date field.
- 5 Optionally, enter a quantity that must be reached to initiate item replacement in the Change Over Qty field.

Note If you enter a changeover quantity, it takes precedence over the effective date.
- 6 Enter another internal part number to replace the original internal part number in the Replacement Item field.
- 7 Specify additional replacement data in the remaining fields.
- 8 Save the record.

Figure 2.10 shows the Item Replacement Maintenance, header, Item Replacement frame, and Replacement Detail frame.

Fig. 2.10
Item Replacement Maintenance (1.23.1), Item Replacement Frame

Item Replacement				
Site	Customer	Replacement Item	Eff Date	Change Over Qty
	002	1-bb-1	2/2/2009	0.0
	4000	1-bb-1	1/1/2008	0.0

Item Number. Enter the item number for which you are defining a replacement item. Items must be predefined in Item Master Maintenance (1.4.1). You cannot specify:

- An item as its own replacement
- A customer item

Site. Optionally, enter the site where this item replacement record should be active. Leave blank to indicate the item should be replaced at all sites.

Customer/Ship-To. Optionally, enter the customer or ship-to code for whom this item should be replaced. Leave blank to indicate the system should replace the item on orders created for any customer or ship-to. Customers can be sold-to addresses. Customers must be predefined in Customer Create (27.20.1.1) and set up in Customer Data Maintenance (2.1.1).

Effective Date. Enter the date this record should be activated. For discrete orders, this determines when the system automatically begins to replace the associated item. For scheduled orders, this determines when the system automatically begins to replace the associated item if a Change Over Qty is not specified. Effective Date cannot be blank.

Change Over Qty. Enter the current item's cumulative shipped quantity at which the replacement item on the record would take effect. This only applies to scheduled orders.

When you enter a value greater than 0 (zero), the system uses this quantity to determine item replacement and ignores the effective date on the record.

Example An item replacement record is defined with an effective date of today and changeover quantity of 200; however, only 150 have been shipped against the current item. Even though the date indicates to switch to the new item, the changeover quantity has not been reached. Since the changeover quantity takes precedence over the date, the switch to the new part does not occur.

Include. Use this field to make a record active.

This field is useful when you have a generic item replacement for all customers or all sites, but you want to exclude a particular customer or site. You can specify the unique customer or site in the header then set this field to No to exclude this record from item replacement that occurs for all other customers or sites.

No: This record is not active.

Yes (the default): This record is active and should be used for replacement.

Quantity. Enter the quantity of the item being replaced.

Replacement Item. Enter a valid item number defined in Item Master Maintenance to use as the replacement item.

Rep Quantity. Enter the quantity of the replacement item. The replacement quantity cannot be 0.

PCO Number. Optionally, enter the number of the product change order (PCO) associated with the change that requires this item to be replaced. This field is for reference only if you are using the Product Change Control (PCC) module. If you are not using the PCC module, enter any tracking number that is meaningful in your system.

Comments. Indicate whether to enter comments and have the system copy and display those comments when you enter an order or quote for the replaced item.

No (the default): You cannot enter comments and the system does not prompt for comments during order entry.

Yes: The Transaction Comments frame displays in Item Replacement Maintenance. Optionally, enter a master reference number, language code, type code, and page number for the comments. In the order-entry program, the Comments field defaults to Yes. Continuing through the order-entry process displays the item replacement comments, unless you change the order-entry Comments field to No.

Auto Accept. Indicate whether replacement should occur automatically when an order or quote is entered for the replaced item.

No (the default): When an order or quote line for the replaced item is entered, the system prompts you to replace the original item with the replacement item and quantity defined in this record. If you respond with Yes, the system replaces the original line item with the replacement item.

Yes: When an order or quote for the replaced item is entered, the system automatically replaces that line item with the replacement item and quantity defined in this record. A message displays indicating that the item is being replaced and the order process continues without interruption.

This value defaults from the corresponding field in Item Replacement Control (1.23.24).

Round Quantity. Indicate the rounding method to use when non-whole number replacement item quantities are encountered.

Round Up (the default): The system rounds up the replacement item quantity to the next whole number. For example, 3.3 is rounded up to 4.

Round Dn: The system rounds down the replacement item quantity to the whole number. For example, 3.7 rounds down to 3. Any quantity less than 1 is rounded down to 0; however, this causes the system to report an error, and you must re-enter the order or quote quantity.

None: The decimal quantity calculated by the system is the quantity of the new item used on the order or quote.

This value defaults from the corresponding field in Item Replacement Control (1.23.24).

Update Customer Scheduled Orders

When you create or modify a line item in Customer Scheduled Order Maintenance (7.3.13), the system displays a frame that lets you search through all lines on the order by specifying a customer item and/or item number as selection criteria. If you enter data in these fields, the system displays an order line frame that shows you contract lines that match the criteria. The order line frame displays the order, line number, cross-referenced items to the customer items, purchase order, customer reference, model, year, and whether the line is the master line; see figure Figure 2.11.

Fig. 2.11
Customer Scheduled Order Maintenance, Customer Item Frame

Ln	Item	PO	Model Yr	Master
1	demo1	po-demo1	2009	<input checked="" type="checkbox"/>

Create Customer Items/Replacement Items from Customer Scheduled Order Maintenance

When the system prompts you for the item number, PO, customer reference, model year, and so on, if the item number you enter does not have an associated customer item, the system prompts you to create one.

Note Menu level security is applied, so if you normally cannot access Customer Item Maintenance, the access restriction still applies.

To save you time, the system prompts you to create the customer item cross-reference from within Customer Scheduled Order Maintenance. If you respond with Yes, the system displays the Customer Item Maintenance frame with the Item Replacement Details frame. Create a new customer item cross-reference or define item replacement effective dates using the Customer Item Maintenance frame.

Create/Update the Master Line

When the master line is the line item entry:

- The Master Line field is set to Yes.
- You cannot update the Customer Item field if there are non-master lines associated with it.
- You cannot delete the line if the master line is part of an order line set with more than one line associated with the set.
- Fields in the Order Line Item Data frame are not protected

Note All fields in the Order Line Item Data frame are protected for non-master lines, except the Cum Start, Container Item, Alternates, and Comments fields.

The system keeps the fields on the Order Line Item Data frame that are protected for non-master lines synchronized with the same fields on the associated master line.

Fig. 2.12
Customer Scheduled Order Maintenance, Master Line

The screenshot shows the 'Customer Scheduled Order Maintenance' window. At the top, it displays 'Ship-From: 10000' and 'Ship-To: 002' on the left, and 'Order: demo1' and 'Honda Delta' on the right. Below this, the 'Item Number: demo3a' is shown. The 'Order Line Item Data' section contains various scheduling and quantity fields such as 'Req Sched Days', 'Req Sched Weeks', 'Req Sched Months', 'Fab Auth Days', 'Raw Auth Days', 'Dock', 'Start Effective', 'End Effective', 'End Eff Qty', and 'Std Pack Qty'. On the right side, the 'UM: EA' and 'Line: 3' are displayed. The 'Master Line' checkbox is checked, and a line points from the text 'Indicates the master line.' below to this checkbox. Other fields on the right include 'Plan SDP Code', 'Plan SDT Code', 'Ship SDP Code', 'Ship SDT Code', 'Netting Logic', 'Cum Start: 3/31/2009', and 'Comments'.

Indicates the master line.

In the line entry frame, all fields are the same except the following:

Customer Ref. If a customer part number exists as a cross-reference to an internal part number specified in the Item field, the customer part number displays here. If one does not exist, the system prompts you to create one.

Validation of this field depends on the setting of Customer Ref is Customer Item in Customer Schedules Control (7.3.24). If Yes, you must provide a valid customer item number. When a customer item defaults, it corresponds to the internal item number entered in the Item field. Alternately, if you enter a customer item in Item, then the customer item defaults in the Customer Ref field. If No, optionally enter any customer reference. The value is not validated.

Master Line. This field is display only. The system determines the value by checking whether an order line set exists for the information you enter and whether the item has the same item replacement schedule.

When the field is Yes, this line item is the master line. You can enter an old internal part number, a future internal part number, or a customer part number when you:

- Update schedules using Customer Plan Schedule Maint (7.5.1), Customer Ship Schedule Maint (7.5.2), or Required Ship Schedule Maint (7.5.3).
- Update required ship schedules (RSSs) using Required Ship Schedule Update (7.5.5) or Selective Req Ship Sched Update (7.5.6).
- Import schedules using EDI.

When creating a scheduled order line, if that line falls into an existing order line set, the Master Line field is set to No because a master line exists. This happens when creating an order line for a replacement item that has the same ship-from, ship-to, customer item, PO, customer reference, and model year as the order line for the item it is replacing.

Set the Cumulative End Effective Quantity

For the master line, you can specify an end effective cumulative quantity in the Order Line Item Data frame; see Figure 2.13.

The combination of cumulative shipped quantities for orders in an order line set determines the open quantity for:

- Schedule requirements
- Picklists and pre-shippers
- MRP requirements

Since a single set of customer planning/shipping requirements can produce two or more required ship schedules in a single run of RSS Update, open quantity calculations differ when using internal part changeover functionality. The system calculates schedule cumulative quantities across each RSS it creates, causing each RSS to act as one linked RSS. When the system calculates the open quantity for any individual requirement on any of the linked RSSs, the open quantity calculation considers all linked RSSs to determine the true open quantity for the requirement. So, open quantity calculations span all RSSs created in the split.

End Eff Qty. If the current line entry is the master line, enter the cumulative quantity for the master line and for all orders in the line set. This becomes the end effective cumulative shipped quantity across the entire order line set. This field is display only for the non-master lines.

The quantity entered controls planning and shipping, along with the start/end effective dates, for the order line. The system does not allocate schedule requirements for a scheduled order line with a total projected cumulative quantity that exceeds the end effective cumulative quantity during RSS creation. When creating the RSS, the system does not plan for any orders in the order line set when the cumulative quantity exceeds the quantity entered here. On the RSS output report, the system lists requirements as either adjusted or deleted from the RSS, depending on the situation, when the order line has reached the end effective cumulative quantity value.

The system displays a warning to alert you that the order line is no longer effective and prompts you to change the quantity when you attempt to ship requirements beyond the end effective cumulative quantity. When you confirm a shipper, the system checks each shipper line that references a sales order for cumulative quantities and displays warnings as appropriate.

The system also displays errors or warnings when the cumulative end effective quantity is exceeded when you use any of the following:

- Shipper Workbench
- SO Shipper Maintenance
- Shipper Gateway
- Container Workbench
- SO Container Maintenance
- Sales Order Shipments
- Pre-Shipper/Shipper Auto Confirm
- RSS Update
- RSS Maintenance

End effective quantities display on certain reports and inquiries.

Fig. 2.13
Cumulative End Effective Quantity Field

The screenshot shows the 'Customer Scheduled Order Maintenance' window. The 'Order Line Item Data' section contains the following fields:

- Req Sched Days: 0
- Req Sched Weeks: 0
- Req Sched Months: 0
- Fab Auth Days: 0
- Raw Auth Days: 0
- Customer Item: [Search]
- Container Item: [Search]
- Charge Type: [Search]
- Dock: [Search]
- Start Effective: [Dropdown]
- End Effective: [Dropdown]
- End Eff Qty: 0.0 (highlighted with a red box)
- Std Pack Qty: 1
- Alternates: [Checkbox]
- Plan SDP Code: [Search]
- Plan SDT Code: [Search]
- Ship SDP Code: [Search]
- Ship SDT Code: [Search]
- Netting Logic: [Search]
- Cum Start: 3/31/2009
- Comments: [Text Area]

Indicates cumulative end effective quantity.

Update Customer Plan/Ship Schedules

Because multiple active internal part numbers can exist for a single customer part number, the system ensures that you maintain and update the correct active schedule for the part number. To do this, the system uses the setting of the Master Line field in Customer Scheduled Order Maintenance for both planning and shipping schedules.

In either Customer Plan Schedule Maint (7.5.1) or Customer Ship Schedule Maint (7.5.2), when you enter a valid item in the Item Number field, the system displays all scheduled order contract lines that match selection criteria. Select a line, then press Go to continue; see Figure 2.14. The screen is the same for Customer Ship Schedule Maintenance.

Fig. 2.14
Customer Plan Schedule Maintenance (7.5.1)

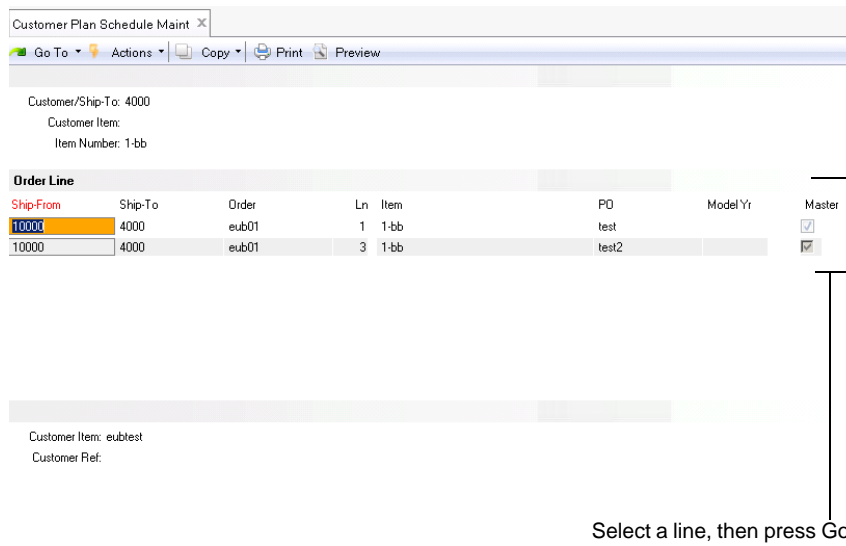

When you enter schedule data for a non-master line, the system automatically directs you to the master line and populates the next frame with the master line data. The fields in the next frame are available for update, but they cannot be changed to reference a non-master line.

All planning and shipping requirements are loaded to the master line, even when the master line is no longer the effective line for the order line set. The RSS update programs obtain requirements from the master line and reallocate them across the order line set, based on items/order lines that are effective according to the item replacement schedule.

When sending schedules using EDI, the system loads schedules based on the master line data for the item, item replacement, or cross-reference customer item. Also, you can create or update an RSS for any line, regardless of the value in the Master Line field. This is because, over time, the effective item/order lines are not always the master line, and therefore, you must have access to the RSS even for a non-master line.

Create an RSS for Customer Schedules

When you have defined internal item replacement records, the system can create an RSS schedule for the current internal part number and one or more of the replacement part numbers, based on the item replacement effective date or cumulative changeover quantity parameters you defined in Item Replacement Maintenance.

When you update the RSS, the system uses the effective date or the cumulative changeover quantities to process schedule data. This includes applying schedule quantities to both the old and new part numbers and calculating schedule cumulative quantities for the new and old part numbers.

When the system processes an RSS that includes a changeover to a replacement internal part number, the system first calculates and creates an RSS using plan/ship schedules for the master line; then, the system adjusts the RSS by distributing the RSS requirements across the effective internal item numbers and their order lines, according to either date or cumulative changeover quantities specified on the item replacement records.

Figure 2.15 shows a two-week schedule of plan and ship cumulative quantities, the calculated RSS for the original item, and the stored RSS for both the original and the replacement item. In the example, note the following:

- The original part number is the master line.
- The effective date for the replacement part is Monday, Feb 8.
- The system uses the original part number (PN) master line settings to calculate the RSS.
- Netting logic is set to 3 — replace beginning of the planning schedule with the shipping schedule (replace logic).

Fig. 2.15
RSS Example for Replacement Part

Replacement effective date is Monday Feb 8.

	PCR	CUM Shipped	Mon Feb 1	Tues Feb 2	Wed Feb 3	Mon Feb 8	Tues Feb 9	Wed Feb 10
Plan Schedule			600			600		
Plan CUM	1000	1000	1600	1600	1600	2200	2200	2200
Ship Schedule			100	100	100	100	100	100
Ship CUM	900	800	1000	1100	1200	1300	1400	1500
Calculated RSS for original PN			100	100	100	100	100	100
Stored RSS for original PN	900	800	100	100	100			
Calculated RSS for replace PN	800	800				100	100	100

Processing Orders with Internal Part Changeover

You process orders with item replacements or customer cross-references as usual when using internal part changeover functionality.

There are some differences, though, when dealing with master lines, scheduled order effective dates, and scheduled order cumulative end effective quantities.

The following topics discuss a typical processing scenario and, following that, major areas of processing while phasing in a new internal part number but keeping the customer part number the same.

- 1 An ECO is initiated to indicate that an internal item is replaced by another internal item.
- 2 The planner estimates a date upon which the old part number runs out based on the old part number's open orders and on-hand quantity.
- 3 The planner determines effective dates of old and new part number or determines the cumulative changeover quantity in Item Replacement Maintenance.
- 4 The order clerk sets up a new order line using Customer Scheduled Order Maintenance for the new internal part number, optionally specifying order line end-dates for old item part number to prevent shipping against expired order lines.

- 5 The order clerk manually creates or receives customer schedules using EDI including customer part number, quantity, and date.
The system creates new customer planning and shipping schedules and calculates the RSS. The system splits the demand among the old and new internal part numbers by effective date or cumulative changeover quantity. The planner uses the RSS to plan for production and purchasing of materials.
- 6 The planner runs MRP to explode the bill of materials (BOM) and routing.
The demand for the old and new part numbers displays on planning documents.
- 7 The shipping clerk uses Picklists/Pre-Shipper-Automatic to print the picklist, which contains the new internal part number.
The system displays remaining inventory of old items to pick.
- 8 The shipping clerk manually picks old parts, depleting old part inventory, or new parts during the transition.
- 9 The shipping clerk confirms the shipment and uses ASN Export to send the ASN.

Picklists

You can continue to ship all remaining inventory of the old item until inventory is exhausted before you start shipping replacement items. You can do this using the same picklist without rerunning the required ship schedule. To use up the remaining inventory of an older item the picklist must be manually changed in Pre-Shipper/Shipper Workbench (7.9.2). The picklist itself shows the following information to assist in using up remaining inventory for replaced items:

- Prints on the picklist the older part numbers that have remaining inventory
- Prints the total inventory balance available to ship

Older inventory items that have inventory on-hand that is not available or is restricted from shipping transactions do not print on the picklist as available to ship.

Shipping

You can continue to ship all remaining inventory of the old item until inventory is exhausted.

During the shipper confirm process, the system lets you ship both the new and old part on the same shipper. The system maintains cumulative shipped quantities for both lines when the shipment is confirmed.

ASNs

When you use Shipment ASN Export (35.4.1) to export advanced ship notices, the system supports multiple internal part numbers for the same customer part number on a single shipper.

When the system sends the ASN, it replaces the internal part number with the customer part number based on Customer Item Maintenance (1.16) records. The system replaces part numbers even when two or more internal part numbers are mapped to a single customer part number.

When the shipper has two or more lines that contain different item numbers that correspond to the same customer item number, the system displays an EDI message that lists each shipper line separately.

EDI

EDI functions also work with customer item numbers and replacement item numbers. When EDI returns:

- A customer item number given a customer/ship-to address and an internal item number, the system finds the correct customer item number when the internal item is part of a chain of item replacement records.
- An internal part number given a customer/ship-to address and a customer item number, the system returns the most effective internal item referenced on the customer item record or item replacement record.
- The value in any field on the customer item record given a customer/ship-to address and a customer item number, the system finds the internal part referenced and returns the most effective internal item number.

Consignment Records

A customer part number in usage consumption can be cross-referenced to an internal part number that has one or more item replacements. So, multiple consignment records can exist with multiple part numbers that relate to a single customer part number.

When you use Document Import (35.1) to import consignment usage, the system determines the part number for the customer part number in the EDI eCommerce message. If the part number has scheduled item replacement, the system determines if the previous part number has existing usage records to consume. If consignment usage records exist for the previous part number, the system consumes the oldest usage for the oldest item first.

When you delete a customer item record, the system checks whether consignment or customer scheduled orders exist that reference the customer item being deleted.

Invoices

When you create a self-bill using Self-Bill Auto Create (27.6.12.4) or Self-Bill Maintenance (27.6.12.1), the system creates two separate self-billing cross-reference records when:

- Two different part numbers correspond to a single customer part number.
- Both part numbers are shipped on a shipper for a self-billing enabled customer.

You can either:

- Combine both shipper lines onto a single self-bill line using the customer part number.
- Create two self-billing lines using the part numbers for both self-billing cross-reference records.

When you combine both shipper lines, the system consumes both self-billing cross-reference records that it creates when it posts the invoice.

Cumulative Shipped Quantities

Customers inform suppliers of the cumulative amount shipped for an item; however, that amount can change at any time.

When customers notify suppliers of the cumulative shipped amount, you can update the amount in the system using Cumulative Shipped Maintenance (7.5.16) or Cum Shipped Reset (7.5.18).

When adjusting the cumulative shipped quantity in Cumulative Shipped Maintenance, the quantity is adjusted only for the line you have specified. You can adjust the cumulative shipped quantity for master and non-master lines in this program.

When you set the cumulative shipped for an item number to zero for the next fiscal year or for other reasons as dictated by the customer, the system keeps track of the reset value and adds it to other values in the order line set to determine the cum shipped for the order line set.

Cumulative Shipped Reset processes all lines in a contract or order line set. It determines the master line and all non-master lines associated with the master line in a set for processing. It also keeps track of each line it has processed, preventing duplicate processing for a single line. This prevents the system from creating multiple history records for a single line.

When you set the cumulative shipped for an item number to zero for the next fiscal year, the system resets each line in the order line set to zero.

View Internal Part Change Over Data

Consolidated Scheduled Order Report (7.5.19) provides a comprehensive view of contract activity based on the customer part number; for example, you can view data for two or more contracts or contract lines for a single customer part number. You can also use the following browses to view data:

- Customer Scheduled Orders Browse (7.5.25)
- Planning Schedule Detail Browse (7.5.26)
- Ship Schedule Detail Browse (7.5.27)
- RSS Detail Browse (7.5.28)
- Shipment History Browse (7.5.29)
- Active Customer Sequence Browse (7.5.30)

Product Lines

A product line is a group of similar items or products. At the corporate level, a company's sales and operations are often planned, reported, and analyzed by product line rather than by individual item or product. This higher-level view of activity makes it easier to relate day-to-day operations to the company sales and operations plan.

By dealing with an aggregate, it is sometimes possible to get a clearer, more accurate picture. For example, a shipment forecast for a product line is more accurate than a forecast for a specific item.

Before you define product lines, you should determine the most important criteria for grouping items. Unfortunately, different departments usually want to divide items differently. For example, Sales may want to group products by target market, but Manufacturing wants to group products by production method.

Product lines group items for accounting and planning purposes:

- Each product line is associated with specific GL accounts for inventory, sales, and purchases. By default, transactions for items belonging to the product line update these GL accounts. You can also set up alternate product line accounts when it is necessary to aggregate inventory, sales, work orders, or purchasing by site. See “Alternate Product Line Accounts” on page 37 for details.
- All of the planning programs—including product line planning, resource planning, MRP, MPS, and forecasting—can be run by product line.
- On sales, purchasing, and service/support management transactions, an item’s taxable status defaults from the product line.

This is a standard cost system, although it can be used as an average cost system. The product line GL accounts are oriented to standard cost accounting. The values for these accounts default from Domain/Account Control (36.9.24). The accounting department is usually responsible for approving these.

See *User Guide: QAD Financials* for details on GL setup.

When setting up similar product lines, you can use a copy function to streamline data entry by copying data from one product line to a new one. You can also use a replacement function to replace all occurrences of one product line with another. In this case, the system updates the references on any opens sales orders, sales quotes, customer scheduled orders, Return Material Authorizations (RMAs), work orders, or on-hand inventory accounts (GL), ensuring correct reporting of account balances.

See page 38.

Product Line Maintenance

Use Product Line Maintenance (1.2.1) to define product lines and their associated accounts.

Fig. 2.16
Product Line Maintenance (1.2.1)

Inventory Accounts	
Inventory Acct: 1500	0200
Inv Discrep Acct: 5900	0200
Scrap Account: 5800	0200
Cost Revalue Acct: 1550	0200

The Taxable and Tax Class fields determine how taxes are usually processed for items belonging to a product line.

GL accounts default from Domain/Account Control. You can accept the default values or enter different account, sub-account, and cost center codes.

The Default Sub-Account/Cost Center and Override fields let you enter the same sub-account or cost center code for all accounts in a product line. These fields are useful if you use standard account codes, but differentiate product lines with sub-accounts or cost centers.

Product Line Accounts

Table 2.2 lists each product line account, the account type, and typical programs that use the accounts.

Note If you are using the optional Customer Consignment Inventory or Supplier Consignment Inventory modules, an additional set of consignment accounts can be updated in Product Line Maintenance. These must be of type Inventory Control. See *User Guide: QAD Sales* and *User Guide: QAD Purchasing*.

Table 2.2
Product Line Accounts

	Account	GL Type	Updated By
Inventory Accounts	Inventory	Inventory Control	Inventory Transactions
	Inventory Discrepancy	Standard	Inventory Counts
	Scrap	Standard	WO Receipt
	Cost Revalue	Standard	GL Cost Change
Sales Accounts	Sales	Standard	Invoice Post and Print
	Sales Discount	Standard	Invoice Post and Print
	COGS Material	Standard	SO Shipment
	COGS Labor	Standard	SO Shipment
	COGS Burden (Variable)	Standard	SO Shipment
	COGS Overhead (Fixed)	Standard	SO Shipment
	COGS Subcontract	Standard	SO Shipment
Purchasing	Purchases	Standard	PO Receipt (Non-Inventory)
	PO Receipts (Accrued AP)	System: PO Receipts	PO Receipt, Supplier Invoice
	Overhead Applied	Standard	PO Receipt
	PO Price Variance	Standard	PO Receipt
	AP Usage Variance	Standard	Supplier Invoice
	AP Rate Variance	Standard	Supplier Invoice
Work Order	Floor Stock	Standard	WO Close
	Material Usage Variance	Standard	WO Close
	Material Rate Variance	Standard	WO Issue, WO Close
	Mix Variances	Standard	Joint Order Set Close
	Cost of Production	Standard	Nonproductive Labor, Subcontract PO Receipts
	Subcontract Usage Variance	Standard	WO Close
	Subcontract Rate Variance	Standard	WO Close
	Work in Process	WIP Control	Work Orders, Backflush, Rep
	Method Variance	Standard	Work Orders, Repetitive, SFC

	Account	GL Type	Updated By
Service	Service Labor	Standard	Call/Project Activity Recording
	Service Overhead	Standard	Call Activity Recording
	Service Expense	Standard	Call/Project Activity Recording
	Expense Due	Standard	Invoice Post and Print
	Service Returns	Standard	Call Activity Recording
	Deferred Revenue	Standard	Contract Maintenance
	Accrued Revenue	Standard	Contract Maintenance

Alternate Product Line Accounts

In some applications, you may need to set up alternate accounts for the same product line.

For example, you can specify only one Inventory account in Product Line Maintenance (1.2.1). If different locations within a site are used for raw materials, WIP, and finished goods, you probably do not want to post inventory transactions for these locations to the same Inventory account.

You can set up alternate accounts in the following programs:

- Assign purchasing accounts to sites or sites and supplier types in Purchasing Account Maintenance (1.2.5).
- Assign work order accounts to sites in Work Order Account Maintenance (1.2.9).
- Assign inventory accounts to sites or sites and locations in Inventory Account Maintenance (1.2.13).
- Assign sales accounts to sites, sites and customer types, sites and distribution channels, or sites, customer types, and channels in Sales Account Maintenance (1.2.17).

If you want to use the product line account code but modify the sub-account or cost center, specify the new sub-account or cost center in the Default field and set the associated Override field to Yes.

Figure 2.17 illustrates Inventory Account Maintenance. The other alternate account programs are very similar.

Fig. 2.17
Inventory Account Maintenance (1.2.13)

Note The Transfer Variance account is defined for only the combination of product line and site. Location is ignored.

During transaction entry, the system automatically retrieves and uses most alternate inventory and purchasing accounts. Alternate work order and sales accounts are retrieved and displayed and can be modified if needed.

Copied Product Lines

Use Product Line Copy (1.2.4) to create a new product line and associated account data by copying an existing product line and associated account data.

Enter the existing product line in the Product Line field, then enter the new product line in the To field. Once you confirm the update, the system displays all associated account data for the existing product line and you can change it as needed.

Fig. 2.18
Product Line Copy (1.2.4)

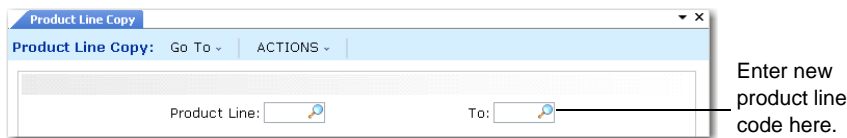

Copied Product Line Accounts

Use Product Line Accounts Copy (1.2.22) to create a new set of accounts by copying an existing product line account type. You can copy any of the following account types:

- Purchasing accounts
- Work order accounts
- Inventory accounts
- Sales accounts
- Inbound accounts
- Outbound Accrual accounts
- Outbound Expense accounts

Note Inbound, Outbound Accrual, and Outbound Expense accounts are used with the optional Logistics Accounting module.

You can also use Purchase Gain/Loss Account Copy (26.22) to copy these accounts.

This function lets you quickly create sets of similar accounts.

See *User Guide: QAD Financials*.

Example You require sales accounts by site and all elements of the account are the same except the sub-account. Create one set of sales accounts for the first site. Then use Product Line Accounts Copy to copy this set to the second site. Modify the copied data with the new sub-account value.

After entering an account type such as sales, you enter the values that identify the set of accounts you want to copy on the left, and the values that you want created on the right. Figure 2.19 illustrates copying the sales accounts for product line 2000 from one site to another.

Fig. 2.19
Product Line Accounts Copy (1.2.22)

After you copy the programs, the system displays the same frame as in Sales Account Maintenance (1.2.17). You can access and edit the new product line accounts you copied directly or in the maintenance program associated with that account type.

You can edit all associated data for the record, except for the header fields that uniquely identify the new record. For many product line account types, the system uses a combination of fields—for example, the product line code, site, and supplier type—to further identify the accounts. After you copy a record, these fields are display only.

Product Line Replacements

Use Product Line Replacement (1.2.23) to replace a product line and update open references to it throughout the system. Both product lines must already be defined in Product Line Maintenance (1.2.1).

You can specify criteria such as item, item type, group, or commodity code to select item records to be updated. A blank in any of the criteria fields means you select all records for that criteria.

Fig. 2.20
Product Line Replacement (1.2.23)

Enter Yes to replace and print a report of exceptions. Enter No to print a simulation report.

You must specify Yes to Update to replace the product line. When you specify Yes, the system:

- Updates all item records you select with the new product line.
- Updates any open work orders, sales orders, sales quotes, customer scheduled orders, RMAs, and Inventory accounts with the new product line.
- Creates a product line change (PLCG-ADJ) inventory transaction to transfer items from the existing Inventory account to the replacement account. The GL transaction associated with the transaction type:
 - Debits the new product line Inventory account with the value of the transferred item
 - Credits the previous account with the value of the transferred item

A report of the replacement activity is generated to the specified output device.

The system uses the following criteria when it updates orders:

- The system updates work orders only when the work order:
 - Status is not C (closed)
 - Type is not E (expense)
 - Does not have operation or transaction history
 - Does not have GL transactions

Note If no GL transactions exist, the system updates all work order-related accounts

- The system updates only open sales orders with 0 (zero) quantities shipped.
- If you manually change the Sales account or Sales Discount account in Sales Order Maintenance (7.1.1) or another program, the changes you make in those programs remain when you copy product line account data and update item records.
- The system updates RMAs only when Use Product Line is set to Yes in SSM Accounting Control (36.9.10).

Sites

The site code identifies a specific warehouse or a group of buildings at the same physical location. The site code in the inventory detail record is a basic unit for inventory control and planning.

Sites are assigned to a specific GL entity and domain. Some programs, such as MRP, work vertically within single sites. Others, such as distribution requirements planning (DRP) and consolidated order processing, work horizontally across two or more sites and possibly two or more domains located in the same or different databases.

The system uses sites for inventory records, item costing, purchasing, sales quotations, sales orders, forecasting, master scheduling, MRP, and DRP. Not all programs operate by site. For example, departments and work centers are not site specific.

Inventory and Accounting

Assign each site a general ledger (GL) entity for financial reporting. Multiple sites can belong to the same entity. The system uses the site you specify in each inventory transaction to determine:

- Which GL entity and accounts to use
- Where to update inventory

Many inventory transactions, such as issues to and receipts from manufacturing and purchasing orders, affect only one site. Other transactions, such as distribution order shipments and receipts or inventory transfers, let you transfer items from one site to another.

When inventory transactions affect more than one site, costs may differ between the two sites. Cost variances are posted to the Transfer Variance account defined for the item product line and site in Inventory Account Maintenance, if available. Otherwise, the account defined for the site in Site Maintenance is used.

A site can be used as the source for GL costs at other sites. When GL costs are updated at the source site, the system automatically generates cost adjustment transactions at any target sites. Site-linking rules are set up in Linked-Site Rules Maintenance (30.18.1).

See *User Guide: QAD Costing* for details on linked-site costing.

Taxes

To calculate taxes, you must set up a corresponding address code for each site in Company Address Maintenance (2.12). On taxable transactions, the system uses the site address to select the correct line-item tax environment.

See “Setting Up Company Addresses” on page 172.

Sites and Enterprise Material Transfer (EMT)

If you are using Enterprise Material Transfer (EMT), you must set up sites to support processing of EMT sales orders. EMT lets you automatically translate sales orders into purchase orders and transmit them to suppliers in electronic data interchange (EDI) format using EDI eCommerce. EMT also manages and coordinates changes so that sales order and purchase order information is synchronized.

Multi-level EMT manages orders across multiple levels within an organization. Order changes can be made at the top or bottom of the hierarchy and are then transmitted up or down to the next level.

Two fields in Site Maintenance are directly related to EMT:

- Use the Default Supplier field to associate a default supplier with each ordering site.
- If you are using direct allocations, set External Supplier to Yes.

See *User Guide: QAD Sales* for details on EMT.

Sites and Domains

Each site must be associated with a domain, which represents a distinct business operation with a single currency and chart of accounts. Your database may have one or multiple domains, depending on your particular implementation. Each domain can include one or more entities, one of which is designated as the primary entity.

All site-related data resides in the domain referenced in the site record. Such a site is considered a *primary site* within the domain.

Setting up sites for a single entity is a very straightforward process. The site entity defaults from the primary entity defined for the domain in Domain Create (36.1.1.1) and the domain defaults from the current working domain. However, when you have multiple entities in different domains, you may need to set up corresponding site records in each domain.

To support inter-site functions across domains, you can optionally create connection records for sites in other domains when you create a primary site. A connection record points to the domain where the actual site-related data is maintained. The other domain can be in the current database or in another connected database.

Important If you are using a Unicode database and have domains with incompatible code pages, you can create site connection records only from the .NET User Interface. Character clients do not support Unicode and always connect to the database using a specific code page. If you attempt to create these records from a character client, an error displays. See *User Guide: QAD System Administration* for more details on Unicode implementations.

When you are using multiple databases operating over a network, the system uses the domain associated with a site to determine where database records should be updated. For example, when a function such as DRP requests information for a site, the system uses the database name associated with the domain record to access that database automatically. The referenced database can be the current database, another database on the same machine, or a remote database on another machine.

See *User Guide: QAD Supply Chain Planning* for information on DRP.

Note To use multiple database features, set up the database names in the network using Database Connection Maintenance (36.6.1).

Site Security

System security features let you determine which users and groups of users can perform inventory transactions at a particular site. Set up site security in Site Security Maintenance (36.3.13.8).

Site security applies to programs that affect inventory data and have a site field as part of the selection criteria. Site security does not affect inquiries, reports, or delete/archive functions. In a multiple-domain environment, site security must be defined separately for each domain.

See *User Guide: QAD Security and Controls*.

Note You can define more granular security by using the programs on the Update Restrictions Menu (36.3.7). These let you define which users can update particular items at sites and locations and which inventory status changes they can make.

Creating Sites

Use Site Maintenance (1.1.13) to set up sites.

Note The Transfer Ownership field is active only if you are using the optional Supplier Consignment Inventory module. This module is described in *User Guide: QAD Purchasing*.

Fig. 2.21
Site Maintenance (1.1.13)

The screenshot shows the 'Site Maintenance' form for Site: 10000. The form includes the following fields and values:

- Site: 10000
- Description: Receiving Site on D1
- Domain: Domain1
- Entity: 1000
- Declarant: 10000
- Default Inventory Status: Y-Y-y
- Automatic Locations:
- Inspection Location:
- EMT Supplier:
- External Supplier:
- Transfer Variance Acct: 5040
- Transfer Ownership:
- PO Transit Location: Transit
- Use Plan/Sched Workbenches:

Site. Enter a unique identifier for a site. Even though DRP may not be implemented in the immediate future, it is a good idea to make site codes unique across all domains.

Entity. Specify the entity associated with this site for managing financial activities. Entity defaults from the primary entity associated with the current domain.

Entity codes identify general ledger (GL) transactions for a specific company within a domain. The entity code assigned to the site determines the GL entity for transactions created when inventory is moved into or out of the site.

Declarant. Specify the address code of the declarant who will make Intrastat declarations for inventory movements into and out of this site. Define the declarant with Declarant Maintenance (29.22.1.20). See *User Guide: QAD Intrastat* for details about Intrastat.

Default Inventory Status. Enter a status code to associate by default with items at this site. See page 50 for details.

Automatic Locations. Set to Yes if you want the system to create new locations whenever an undefined value is entered in an inventory transaction. See “Automatic Locations” on page 48 for details.

Inspection Location. Specify a code identifying the location where purchased items needing inspection are received.

This field defaults from the Inspection Location field in Purchasing Control (5.24) and sets the default value for the same field in Item-Site Planning Maintenance when new item-site records are defined.

Note To update the inspection location in existing item-site records to the one specified for the site, use Inspection Location Population 2 (1.25.2).

This inspection location is used during receipts only when Inspection Required is Yes for the purchase order line item.

During receipts, the system searches for an inspection location in this order:

- a The inspection location specified for the site and item in Item-Site Planning Maintenance (1.4.17)
- b The inspection location defined for the site in Site Maintenance (1.1.13)
- c The inspection location defined in Purchasing Control (5.24)

Domain. Enter the code identifying the domain defined in Domain Create (36.1.1.1) that you want to associate with this site. You must specify a valid, active domain that you have access to. The default is your current working domain.

If you change the default, the system ensures that the site does not already exist as a primary site in a different domain, or an error is generated.

Note The EMT Supplier and External Supplier fields are used by Enterprise Material Transfer (EMT). See *User Guide: QAD Sales*.

Transfer Variance Account. Enter the GL account code used to track cost variances for inventory transfers between two sites. This must be a valid active account of type Standard. This account defaults from the Transfer Variance account set up in Domain/Account Control (36.9.24), but you can change it to another account with a standard GL type. Product-line specific accounts can be defined in Inventory Account Maintenance (1.2.13).

Inventory activity typically occurs at the site where orders are processed. However, in a multi-site environment, you can ship, receive, or issue inventory from a different site. If the other site has different costs for an item, a variance occurs.

This variance is posted to the Transfer Variance account. The system uses the following logic to find a Transfer Variance account in relevant inventory transactions:

- A value defined for the item product line and site in Inventory Account Maintenance
- A value defined for the site in Site Maintenance
- A value defined for the domain in Domain/Account Control (36.9.24)

If the two sites are in different entities, an intercompany transaction may also be posted. The system automatically updates costs at both the central and remote sites.

- When the transfer-from and transfer-to sites are in different entities, the system automatically generates the appropriate intercompany balancing entries using the Cross-Company Inventory Control account associated with the current domain and the intercompany codes associated with the entities.
- When the two sites are in the same entity, a balancing debit or credit is posted to the Transfer Clearing account defined in Inventory Accounting Control (36.9.2).

Note The PO Transit Location field is used by the Logistics Accounting module to store items on PO shippers that are owned by your company but must be paid for before they actually arrive.

Use Plan/Sched Workbenches. Set this field to Yes to enable the .NET UI-only Planning and Scheduling Workbenches for this site.

No: You cannot run the Planning and Scheduling Workbenches for this site. Use Repetitive Menu programs as usual.

Yes: You can use the Planning and Scheduling Workbenches that contain both a master scheduling workbench (MSW) and production scheduling workbench (PSW) for this site.

When a site is enabled to run the MSW and PSW workbenches, Capacity Requirements Planning (CRP) runs as part of MRP for orders that have a P(lanned) status. When CRP runs as part of MRP, the system explodes planned orders as they are created, and lets you access the orders via the work center schedule resource in MSW. So, once a site is enabled to run MSW or PSW, and you run MRP for the site to create planned orders, then within MSW, you can retrieve the orders for the item/site.

Setting this field to Yes also disables the following programs:

- Schedule Maintenance (18.2.1 and 18.22.2.1)
- Schedule Explosion (18.2.4)
- Cumulative Completed Maintenance (18.6)
- Line Schedule Workbench (18.22.1.10)
- Schedule Explosion (18.22.2.4)
- Cumulative Completed Maintenance (18.22.2.6)
- Planned Repetitive Schedule Approval (23.8)

Creating Site Connection Records

When you click Next after the first frame of Site Maintenance in a multiple-domain environment, you can optionally create connection records in related domains when you create a new primary site.

The system generates a list of active domains in the current database and all databases defined in Database Connection Maintenance. You can choose which domains to update from this list.

Before the list displays, you are prompted to set a default for the Update field. Set this to Yes if you want to create connection site records in most related domains. You can then change exceptions to No.

Fig. 2.22
Creating Connection Records

Domain	Name	Database	Update
DOMDM	DOMDM	qaddb	<input checked="" type="checkbox"/>
DOMEU	DOMEU (NAME)	qaddb	<input checked="" type="checkbox"/>
DOMEUR	DOMEUR - DO NOT Use	QADDB	<input checked="" type="checkbox"/>
DOMGB	DOMGB Name	qaddb	<input checked="" type="checkbox"/>
DOMUSA	DOMUSA (name)	qaddb	<input checked="" type="checkbox"/>

Note In a multi-database environment, all databases must be connected or you cannot create a new primary site record. This is to ensure that the site does not already exist as a primary site in a domain in another database. This is also true when you delete a primary site, although in this case, additional restrictions may prevent you from deleting the site.

Most of the data associated with the site connection record defaults from the primary site record but is validated in the target domain:

- The entity associated with the site is set to the primary entity of the domain where the connection record is being created.

- The connection record is created with the primary site's default inventory status if the inventory status is valid in the connection domain. Otherwise, the first inventory status in that domain is used.
- The site connection record is created with the same Transfer Clearing account, sub-account, and cost center as the primary site if this combination is valid in the target domain. Otherwise, the value from Inventory Accounting Control (36.9.2) in the target domain is used. If this is not found, the value from Domain/Account Control (36.9.24) in the target domain is used.

Deleting Sites

You can use Site Maintenance to delete a site record. The system performs a number of validations if you attempt to delete a site to ensure that it is not referenced and required by other data and transactions. You cannot delete a site if it is associated with any of the following:

- Locations
- Inventory quantities
- Item-site planning data
- Open-quantity purchase requisitions
- Purchase orders with an open quantity to receive
- Purchase order receipt history data
- Sales quotes with an open quantity to release
- Sales orders with an open quantity to ship or an invoiced quantity
- Open work orders
- Physical inventory count tags
- Inventory movement security records
- Projects, project activity orders, worksheets, or worksheet detail records created using Project Realization Management (PRM) functions
- Family hierarchies, family-level plans, or end-item operations plans created using Enterprise Operations Plan functions

If a primary site passes all these validations, the system performs additional domain-related validations:

- All connection records must also be able to be deleted.
- In a multiple-database environment, the system checks that all databases are connected before you can delete a primary site record.

If no other restrictions apply to the deletion, the primary site is deleted and all connection records are also deleted from other domains in this and connected databases. The system does not check other domains when you delete a connection record.

Locations

Use Location Maintenance (1.1.18) to specify areas within a particular site where inventory is stored; see Figure 2.23. A location can include shelves, bins, tanks, lots or other storage areas. Each location's parameters identify what can be stored there and how that inventory can be used.

Each time you perform an inventory transaction, such as an issue, receipt, or transfer, you must specify both a site and location. Use Item Master Maintenance (1.4.1) or Item Inventory Data Maintenance (1.4.5) to define default sites and locations for individual items. Use Item-Site Inventory Data Maintenance (1.4.16) to assign site-specific locations to an item. When considering location defaults, the system searches for a site-specific record first. If the record does not exist, location defaults from Item Master Maintenance.

See “Item Inventory Data” on page 8.

Note If detailed inventory security is needed, use programs on the Update Restriction Menu (36.3.7) to designate who can update particular items at specific locations and which inventory status changes they can make.

A site can have an unlimited number of locations. Although the system permits the use of blank location codes, this is not recommended.

Note The Transfer Ownership field is active only if you are using the optional Supplier Consignment Inventory module. See *User Guide: QAD Purchasing*.

Fig. 2.23
Location Maintenance (1.1.18)

The screenshot shows the 'Location Maintenance' window with the following fields and values:

- Site: 10000 NJ Plant
- Location: 100
- Description: Raw materials/assemblies
- Inventory Status: 10
- Project: (blank)
- Date Created: 06/27/2001
- Permanent:
- Type: stockrm
- Single Item:
- Single Lot/Ref:
- Capacity: 200
- UM: EA
- Reserved Locations:
- Transfer Ownership:
- Physical Address: (blank)

When establishing a naming convention for location identifiers, consider the picking order specified in Inventory Control (3.24). When items are picked by location code, work-order and sales-order picklist functions check locations in ascending or descending order according to the Inventory Control setting. Because of this, numeric location codes such as 1000, 1100, and 8000 are recommended. If you use significant codes and allocate in ascending order, the system checks locations in alphabetical order; for example, Inspect would come before Storage.

See “Setting Up Inventory Control” on page 234 for details.

Permanent/Temporary Locations

Locations can be defined as permanent or temporary. When you define a location as permanent, the system maintains all location detail records for that site/location until they are deleted using Zero Balance Delete/Archive (3.23). Since detail records are maintained, locations with zero balances appear on reports.

If you define a location as temporary, the system automatically deletes inventory detail records when the location's balance falls to zero. It does not delete the location code. Since zero balance locations do not have detail records, they do not appear on reports.

Automatic Locations

The system can automatically create location codes whenever you enter an undefined value. Do this by setting Automatic Locations to Yes in Site Maintenance (1.1.13). This option is useful if you frequently need to define a new location while entering a transaction.

Note The system automatically creates new location codes without verification. This means you can inadvertently create a new location code from a typing error. For example, if you type STWCK instead of STOCK, the system creates a location code called STWCK.

If a site has a complex network of storage locations, automatic locations may be a useful feature. An alternate approach is to set up your main locations in Location Maintenance and define sublocations using the lot reference field.

Location Types

Some items require special storage conditions, such as temperature control or sterile environments. Storing these items in an inappropriate location can cause inventory to become unusable. Location type codes enable you to control the type of inventory stored in a location.

Specify the type code for a location in Location Maintenance. Then, identify the items that require this type of storage by specifying the same type code for them in Item Master Maintenance (1.4.1), Item Inventory Data Maintenance (1.4.5), or Item-Site Inventory Data Maintenance (1.4.16).

When the item is received, transferred, or counted using a cycle count or a tag count, the system verifies that the type associated with the location and item match. If the types do not match, an error displays and the transaction cannot be processed. This is useful for items with special storage requirements, such as temperature or humidity. The location type can indicate this and comments can describe the exact requirements.

Single Item Locations

Some locations can be used to store different types of the same kind of material. For example, a vat may contain any kind of liquid, such as olive oil, ammonia, or acetic acid. However, at any one time, you only want one type of liquid in that location.

Define these locations as single-item locations by setting Single Item to Yes in Location Maintenance. When a location is designated as a single item location, it can only have an on-hand balance for a single lot of one item at a time.

Note Single item applies to lot reference also, if it is used.

Reserved Locations

Enter Yes in Reserved Locations to display the second frame of Location Maintenance where you assign reserved locations to specified customers. Reserved locations let you dedicate inventory to a specific customer or customers to ensure an adequate supply for sales orders.

Note Use Reserved Location Maintenance (2.1.9.1) to make adjustments to the reserved location data set up in Location Maintenance. See page 178.

Fig. 2.24
Location Maintenance (1.1.18), Reserved Location Data

Site: 10000		NJ Plant	
Location: 100		Raw materials/assemblies	
Address	Name	Primary Location	Detail Allocate
		<input type="checkbox"/>	<input type="checkbox"/>
Address	Name	Primary Location	Detail Allocate
<input type="text"/>		<input type="checkbox"/>	<input type="checkbox"/>

Enter a customer address and indicate whether this location is the customer's primary location; also specify whether detail allocations should normally be created. The primary location always defaults on new sales quotes and orders. Each customer can have only one primary location at a site, but you do not need to designate any reserved location as primary.

When you create a sales order for a customer with a reserved location, the reserved location defaults during line-item entry. For other customers, the system automatically blocks sales order line-item entry or shipment from a reserved location.

Note When doing general allocations in Sales Order Maintenance, the system does not update location detail records for locations with inventory status codes that have Available set to No—the recommended setting for reserved locations. In these cases, entering subsequent sales orders for the same item in non-reserved locations may display an incorrect quantity available to allocate at the bottom of the line-item frame. Set Detail Allocate to Yes in Location Maintenance to avoid this situation.

Important The system does not prevent you from reserving the same site and location for multiple customers. You must ensure that only appropriate customers are assigned to reserved locations. Use Reserved Location Browse (2.1.9.2) and Report (2.1.9.3) to monitor customer associations with reserved locations.

Reserved Locations and Inventory Status Codes

The management of inventory in a reserved location depends on assigning an appropriate inventory status code to the location.

See “Inventory Status Codes” on page 50.

Important Since all inventory detail records in the location must have the correct status code, you should create new locations for the reserved inventory.

Set up the status code in Inventory Status Code Maintenance (1.1.1) before assigning it to the new location in Location Maintenance:

- Set Available to Allocate to No. This prohibits allocating inventory from reserved inventory to undesignated customers. This setting does not affect customers who have been assigned a reserved location.
- Set Nettable to No. This excludes reserved inventory from Materials Requirement Planning (MRP) functions. Otherwise, the system counts reserved inventory in its planning functions, and inventory shortages for other customers may occur.

- Set Overissue to Yes or No, depending on your inventory management policy on issuing inventory from a location that has a zero or negative inventory balance.
- Set up restricted transactions for all non-sales order transactions. This prohibits non-sales order transactions for reserved locations inventory. For example, apply restrictions to work order component issue, DRP shipments, RMA shipments, issue and receipt transactions, and others that may allow other order functions to access reserved-location inventory.

Effect of Reserved Locations in Sales Order Functions

When an item is entered on a sales order, the default location is normally the one associated with the item in Item Master Maintenance. When reserved locations exist for the order customer, a new method is used to determine the default location.

The system checks for reserved location records for the ship-to customer address, then the sold-to address, and finally the bill-to address. If a record is found with Primary set to Yes, this location is used as the default. If reserved locations are defined for one of the order address records but none are designated as primary, the first reserved location found alphabetically within the site is used as the default.

Physical Address

In some business environments, formal shipping documents must accompany any movement of goods between distinct addresses. While this typically occurs between two sites, locations within a site can also have distinct physical addresses. When two locations involved in a transfer have different addresses defined in Location Maintenance and the proper shipping groups and inventory movement codes are defined, you are prompted to create a shipper in the transfer functions.

See *User Guide: QAD Sales*.

Inventory Status Codes

Use Inventory Status Code Maintenance (1.1.1) to create and modify inventory status codes.

- Assign inventory status codes to sites with Site Maintenance (1.1.13) and locations with Location Maintenance (1.1.18).
- Optionally assign default inventory status codes for purchase order or work order receipts to individual items using Item Master Maintenance (1.4.1), Item Inventory Data Maintenance (1.4.5), or Item-Site Inventory Data Maintenance (1.4.16).

The inventory status code determines whether the inventory balance at a site or location is:

- Nettable for material requirements planning calculations.
- Available for sales order and work order allocations. Allocations are used to reserve inventory and assist in picking inventory to be shipped or issued.
- Issued even if the site or location has a zero or negative inventory balance.
- Not available for particular kinds of inventory transactions. For example, material that is located in scrap locations should not be used for sales order issues.

Fig. 2.25
Inventory Status Code Maintenance (1.1.1)

You must associate an inventory status code with every site or location you set up. You may want to create a blank inventory status code to use for most situations. This status code should be both nettable and available, with no restricted transactions.

When QAD Warehousing is active, the system changes the status of inventory to reflect the good status associated with the current fail status as specified in the Warehouse Management Data frame in Inventory Status Code Maintenance. To activate QAD Warehousing, set Active to Yes in Warehouse Management Control (4.25).

Status Defaults

Each site's inventory status defaults to any locations you add to that site. You can modify inventory status for individual locations as needed.

Item quantities received into inventory are assigned an inventory status based on their associated item master data, inventory detail, or the site or location into which they are received. You can use Inventory Detail Maintenance (3.1.1) or Detail Maintenance by Item/Lot (3.1.2) to assign a different status to an item's quantity on hand.

If you are using the Regulatory Attributes module, you can also define inventory attributes, including status, in Work Order Maintenance. These attributes are then used by default during the work order receipt.

See Chapter 5, "Regulatory Attributes," for information.

You can modify default inventory attributes, including status, during most receipt functions if the receipt location does not already include inventory with different attributes.

Overissue Policy

Whether or not you allow overissues depends on your own policies and procedures. Some organizations determine that to maintain accurate inventory balances, negative balances cannot be permitted.

In an online, interactive system, inventory records are updated when inventory transactions are processed. Information is sometimes entered in batch when people are not able to enter transactions in real time. Without controls, inventory balances may temporarily be driven negative. However, after all the transactions are entered, inventory balances should not be less than zero.

If all of the following are in place and executed, inventory balances should be accurate:

- Procedures for recording inventory movement
- Procedures for data entry
- Regular cycle counts
- Good stockroom practices such as proper labeling and organization
- Controlled stockroom (that is, people cannot just walk in and take material)

If the Overissue field for the inventory status code is set to No, you may be unable to record a shipment transaction for inventory that is known to have shipped, because a work order receipt has yet to be processed. To prevent unnecessary delays in processing transactions, the Overissue field can be set to Yes. At the end of the day, a report can be run to check for negative balances. Regular cycle counts also help identify problems.

In some regulatory environments, it may be better to set the Overissue field to No. Here, data entry procedures should be developed to ensure the timely entry of inventory transactions. This may be particularly true when there are critical items controlled by lot or serial number.

Note Overissues are not prevented when components are issued during inventory, work order, and repetitive backflush transactions. These transactions assume that component inventory must have been issued if a parent is received or an operation has been completed.

Restricting Transactions

You can use inventory status codes to control and manage how items, sites, and locations are used in the system.

- You can specify whether particular kinds of transactions can occur for individual items. For example, you typically inspect purchased items. Use the PO Receipt Status field in Item Master Maintenance to assign items received on purchase orders a default status that restricts inventory transfers.
- You can determine for sites and locations whether you can initiate particular transactions that affect them. For example, assign a scrap location an inventory status code that restricts issues.
- You can also indicate whether particular transactions can be initiated using CIM-load functions for items, sites, and locations.

Not every inventory transaction can be restricted. Some system-generated transactions are required to maintain data integrity. Table 8.2 in Chapter 8, “Inventory Control,” lists inventory transaction types and indicates which ones cannot be restricted.

See “Transaction Types” on page 243.

Note If detailed inventory security is needed, use programs on the Update Restriction Menu (36.3.7) to designate who can update particular items at specific locations and which inventory status changes they can make.

Some transaction types are not listed in Table 8.2. These transaction types are used exclusively to prevent or allow actions in the system. Since no inventory movement occurs, a transaction history record is not created.

Table 2.3 lists these transaction type codes with a brief description and the name of one of the programs that creates the transaction.

Note Some of these transactions are created in more than one program. In this case, the table simply indicates a typical program associated with the transaction and is not intended to be a complete list.

Table 2.3
Transaction Types Used to Restrict Actions

Transaction Type	Description	Program Creating
ADD-FC	Create a forecast for an item.	Forecast Maintenance (22.1)
ADD-PO	Add an item to a purchase order.	Purchase Order Maintenance (5.7)
ADD-PS	Create a product structure relationship.	Product Structure Maintenance (13.5)
ADD-RE	Create a repetitive schedule.	Schedule Maintenance (18.22.2.1)
ADD-RMA	Add an item to a return line on a service/support RMA.	RMA Maintenance (11.7.1.1)
ADD-SEO	Add an item to a material order.	Material Order Maintenance (11.11.1)
ADD-SO	Add an item to a sales order or RMA issue line.	Sales Order Maintenance (7.1.1)
ADD-SQ	Add an item to a sales quote.	Sales Quote Maintenance (7.12.1)
ADD-WO	Create a work order for an item.	Work Order Maintenance (16.1)
INC-PS	Create a product structure relationship by incorporating a PCO.	Incorporation (1.9.7.5)
ISS-RMA	Receive an item into inventory on a service/support RMA.	RMA Receipts (11.7.1.13)

You can also use item status codes, defined with Item Status Code Maintenance (1.1.5), to restrict transactions for an item. Item status codes typically reflect the status of an item in its life cycle from planning through design, production, and obsolescence. In contrast, inventory status codes indicate what can be done with an item based on its physical location or its current use in the system.

Pricing

This chapter discusses the two pricing models available: best pricing and list/discount table pricing.

***Introduction to Pricing* 56**

Describes how the system handles automatic pricing and pricing models.

***Using Best Pricing* 58**

Describes how to use the best pricing features.

***Using List/Discount Table Pricing* 86**

Describes how to use list/discount table pricing.

Introduction to Pricing

The system supports automatic pricing in a number of key transactions. The simplest way to establish prices is by associating prices with items in Item Master Maintenance. However, this approach is often too inflexible to meet the needs of modern companies.

For greater flexibility, there are three pricing models based on price lists: best pricing, list/discount table pricing for suppliers, and list/discount table pricing for customer schedules and RMA receipts. These models are represented by submenus on the Pricing and Discount menu (1.10).

- Use price lists based on the best pricing model for sales orders, sales quotes, and issue lines on Service/Support Management (SSM) return material authorizations. Set up these price lists in SO/SQ/RMA Issues Pricing Menu (1.10.1).
- Use price lists based on the list/discount table model to create price lists that are assigned to suppliers in Supplier Maintenance, default to new purchase requisitions, blanket orders, purchase orders, and supplier schedule orders, and cannot be specified in customer scheduled orders or RMA credit price lists. Set up these prices in Supplier Pricing Menu (1.10.2).
- Use price lists based on the list/discount table model to create price lists that are assigned to customers in Customer Maintenance; default to new customer schedule orders and RMA Receipt lines; and cannot be specified in global requisitions, purchase orders, blanket purchase orders, or supplier scheduled orders. Price lists can also be created here for use by the Forecast Simulation module in the Detail Forecast Report. Set up these prices in Cust Sched/RMA Rcpt Pricing Menu (1.10.3).

Use Price List Reclassification (1.10.24) to automatically change a supplier price list to a customer scheduled price list and vice versa. You can run the utility in simulation mode to view effects first.

Table 3.1
Pricing Menus

	Menu	Menu Label	Program
Best Pricing Model	1.10.1	SO/SQ/RMA Issues Pricing Menu	
	1.10.1.1	Price List Maintenance	pppimt.p
	1.10.1.2	Price List Inquiry	pppii01.p
	1.10.1.3	Price List Report	pppirp01.p
	1.10.1.5	Price Lists by Customer Inquiry	pppii02.p
	1.10.1.6	Price Lists by Item Inquiry	pppii03.p
	1.10.1.8	Price List Copy	pppicp.p
	1.10.1.13	Pricing What-If Inquiry (S/O)	sopiwiq.p
	1.10.1.15	Customer Orders by Price List Inquiry	pppii04.p
	1.10.1.17	Sales Order Price Inquiry	soppiq.p
	1.10.1.18	Sales Quote Price Inquiry	sqppiq.p
	1.10.1.24	Pricing Control	pppipm.p

	Menu	Menu Label	Program
Supplier List/Discount Model	1.10.2	Supplier Pricing Menu...	
	1.10.2.1	Supplier Price List Maintenance	ppvnpmt.p
	1.10.2.2	Supplier Price List Browse	ppbr003.p
	1.10.2.3	Supplier Price List Report	ppvnpgrp.p
	1.10.2.4	Supplier Price List By Item Report	ppvnpgr2.p
	1.10.2.5	Supplier Price List Copy	ppvnpccp.p
	1.10.2.6	Supplier Price List Gen By Item	ppvnpcup.p
Cust Sched/RMA Receipt List/Discount Model	1.10.3.	Cust Sched/RMA Rept Pricing Menu...	
	1.10.3.1	Cust Schedule Price List Maint	ppcspmt.p
	1.10.3.2	Cust Sched Price List Browse	ppbr112.p
	1.10.3.3	Cust Schedule Price List Report	ppcsprp.p
	1.10.3.4	Cust Scheduled Price List by Item	ppcspr2.p
	1.10.3.5	Cust Schedule Price List Copy	ppcsccp.p
	1.10.13	Volume Discount Maintenance	sosdmt.p
	1.10.14	Volume Discount Browse	sobr008.p
	1.10.24	Price List Reclassification	pppcup.p

Service price lists are created in Service/Support Management and used for contract pricing and call billing. They are defined and managed entirely within SSM. See *User Guide: QAD Service/Support Management*.

Figure 3.1 illustrates how the system applies the best pricing and list/discount pricing models to various orders.

Fig. 3.1
Two Pricing Models

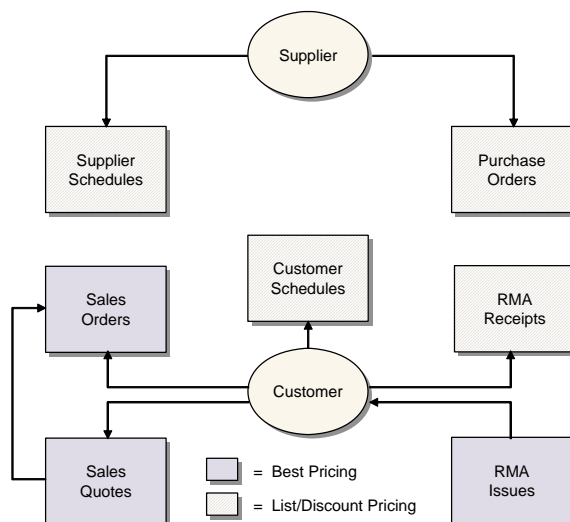

Using Best Pricing

Best pricing, or sales order pricing, enables you to create price lists that accommodate a wide range of pricing situations. Instead of matching price lists strictly through items or product lines, the system can determine best prices using flexible categories of items and customers called *analysis codes*.

Figure 3.2 gives steps for setting up a typical sales order pricing operation. Each step is discussed in detail in the sections that follow.

Fig. 3.2
Sales Order Pricing Workflow

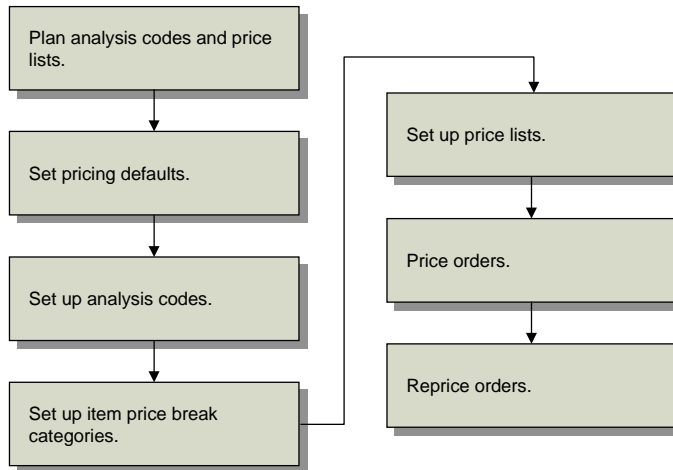

Sales order pricing includes both the Analysis Code menu (1.8) and the SO/SQ/RMA Issues Pricing menu (1.10.1). Sales order price lists are used to price orders you create in Sales Order Maintenance (7.1.1), Sales Quote Maintenance (7.12.1), and RMA Maintenance (11.7.1.1). Price break categories allow volume price breaks for multiple items. Break categories are assigned to item numbers.

For more information on RMAs, see *User Guide: QAD Service/Support Management*.

Planning for Best Pricing

To use best pricing, you need to plan analysis codes and price lists. How you use analysis codes depends on how you organize items and customers. How you use price lists also depends on how you organize items, but also on your product structures, and whether you manufacture configured products, offer discounts on quantity volume, and many other factors.

Planning Analysis Codes

To plan analysis codes, do the following:

- 1 Collect and review your company's current pricing policies, procedures, and associated structures.
- 2 Determine the benefit of using analysis codes with your current or planned pricing practices. Analysis codes are best suited to extensive, complex pricing structures.

- 3 If you decide to use analysis codes, determine how you want to group inventory items and customers in relation to pricing. Establish a list of unique codes identifying these groups.
- 4 For each customer and item group, determine how you want to select members using the conditions available in Analysis Code Selection Maintenance.
- 5 Consider the usefulness of combining analysis codes into hierarchical pricing structures. All attributes of child analysis codes are inherited by the associated parent analysis code.
- 6 Create a visual diagram of how you want to link analysis codes.
- 7 Review and modify all analysis codes defined and determine how they will be associated with one or more price lists.

Planning Price Lists

In planning for price lists, consider the following questions:

- 1 Do you offer promotional discounts?
- 2 Do you engage in joint cooperative marketing agreements with retailers where the amount of cooperative marketing is based on the volume purchased over a period of time by the retailer?
- 3 Do you use coupons?
- 4 Do you convert savings resulting from seasonal fluctuations in materials costs into customer discounts?
- 5 Do you offer additional discounts to customers in a geographical area where a product is not moving quickly?
- 6 Do you maintain a minimum price for a product that is the lowest acceptable price offered, regardless of the number of discounts?
- 7 Do you offer volume discounts based on quantity and/or value?
- 8 Do you negotiate credit terms with your customers?
- 9 Do you negotiate freight terms and freight discounts with your customers?
- 10 Do you want some discounts exclusive of all other discounts or combinable with other discounts?
- 11 Do you want volume discounts based on a range of similar products?

Setting Pricing Defaults

Use Pricing Control (1.10.1.24) to set pricing defaults.

Discount Combination Type. Enter either Additive or Cascading to instruct the system what to do when multiple price lists apply. See “Discount Sequences” on page 71.

Automatic AC Regen for Customers/Items. Enter Yes to have the system automatically add new customers or items to existing analysis codes. Otherwise, enter No. If No, Analysis Code Detail Build must be run after new customers and items are added.

Automatic AC Regen for Edits of Customers/Items. Enter Yes to have the system automatically add modified customers or items to existing analysis codes. Otherwise, enter No. If No, Analysis Code Detail Build must be run after existing customers and items are modified.

QO Default Price Date. Price date indicates which price lists are effective for a quote. Specify a default price date by entering Due Date, Order Date, Promise Date, or Required Date.

Note On a sales quote, Order Date is the field labeled Quote Date.

Price QO by Line. Enter Yes to recalculate prices as lines are entered in a quote. This updates prices immediately if a combination of items or quantities qualifies for a better price. Enter No to recalculate prices only once, when the quote is complete.

QO Factor Rounding. The number of decimals to which factors are rounded in a sales quote. The default is 3. This field only has effect when discounts are displayed as factors.

Display QO Discounts as. Valid values are Discounts or Factors. For a 10% discount, the factor is 0.90 (or 1–0.10). The default is Discount. This also controls the format for prompting of a discount.

SO Default Pricing Date. Specify a default price date for sales orders by entering Due Date, Order Date, Performance Date, Promise Date, or Required Date.

Price SO by Line. Enter Yes to recalculate prices as lines are entered in a sales order. Enter No to recalculate prices only once, when the order is complete.

SO Factor Rounding. The number of decimals to which factors are rounded in a sales order. The default is 3.

Display SO Discounts as. Valid values are Discounts or Factors. For a 10% discount, the factor is 0.90 (or 1–0.10). The default is Discount. This also controls the format for prompting of a discount.

Promotions Prefix. This field lets you group price lists for reporting.

Setting Up Analysis Codes

In best pricing, you classify customers and products using analysis codes. Analysis codes are based on characteristics, such as region, salesperson, or item number, and can be linked to form combinations or sets. For example, analysis codes can link regions, as shown in Figure 3.3.

Fig. 3.3
Parent and Child Analysis Codes

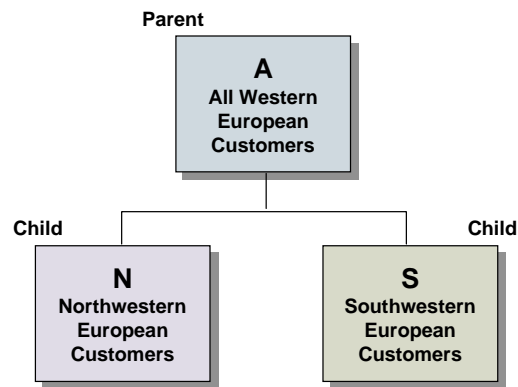

- Analysis Code N groups customers in Northwestern Europe.
- Analysis Code S groups customers in Southwestern Europe.
- Analysis Code A combines the two groups by linking codes N and S.

Code A is referred to as a *parent code* because Codes N and S are linked to it. Codes N and S are referred to as *child codes*.

Fig. 3.4
Map of Example Region Codes

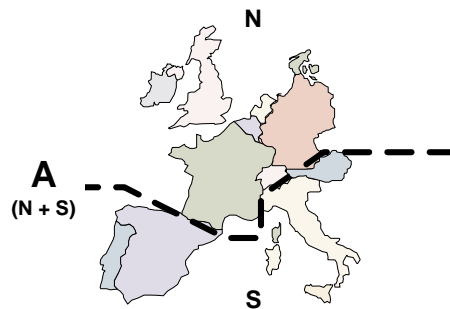

Analysis code linking uses OR logic. For example, if code A links codes N and S, any customer meeting the code N or code S criteria is included in code A.

Figure 3.5 outlines commonly used procedures for setting up and managing analysis codes. Each procedure is discussed in detail in the sections that follow.

Fig. 3.5
Analysis Code Workflow

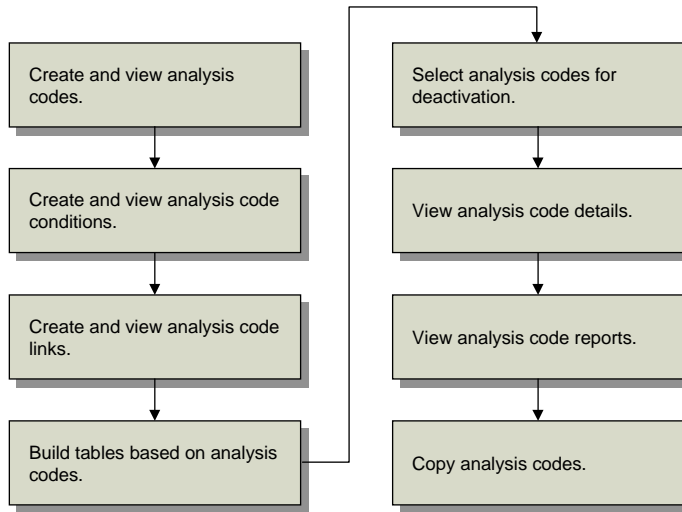

Creating Analysis Codes

Create analysis codes for customers and items in Analysis Code Maintenance (1.8.1). Use Analysis Code Inquiry (1.8.2) to view analysis codes.

Fig. 3.6
Analysis Code Maintenance (1.8.1)

Type. Valid values are item or customer.

Code. Enter an alphanumeric code identifying a group of customers or items.

Description. Enter a brief description of this particular code. This displays in inquiry screens.

Active. Enter Yes. If No, a warning displays when you create a price list with this analysis code.

Note This setting has no impact on the active status of customer and item nodes associated with this analysis code. You can modify the active status of nodes in Analysis Code Detail Maintenance (1.8.13).

Comments. Enter Yes to review or update comments.

Use Analysis Code Report (1.8.17) to view details for a range of analysis codes. Enter the analysis code type, analysis code range, and analysis detail selections to be included on the report.

Creating Analysis Code Conditions

Use Analysis Code Selection Maintenance (1.8.4) to define how members are selected for inclusion in an analysis code group. Use Analysis Code Selection Inquiry (1.8.5) to review analysis codes and their condition fields and ranges.

Fig. 3.7
Analysis Code Selection Maint (1.8.4)

Type. Valid values are item or customer.

Code. Enter an analysis code you created previously, considered the parent code.

Condition Field. Enter a characteristic or qualifier. You can apply more than one condition to an analysis code. If multiple qualifying conditions are selected, AND logic is used. For example, if Condition Field is set to Salesperson 1 and a second Condition Field is set to Salesperson 2, only records meeting both conditions are selected.

Table 3.2
Valid Conditions

Customer Conditions		Item Conditions	
Bill-to	Salesperson 2	Article	Item Number
Class	Site	Break Category	Product Line
List Type	Sort Name	Buyer/Planner	Site
Number	Type	Description 1	Type
Region	User Field 1	Description 2	User Field 1
Salesperson 1	User Field 2	Group	User Field 2

Wildcard. Enter one of the following wildcards:

- (.) period—a single position wildcard. For example, .2 indicates any selection with 2 in the second position.
- (*) asterisk—a multiple position wildcard. For example, *2 indicates any item with 2 in the last position.

From. For a condition, enter the beginning range to be included in the analysis code.

To. For a condition, enter the ending range to be included in the analysis code.

Linking Sets of Analysis Codes

By linking analysis codes, you can organize customers and items in a variety of ways. Item analysis codes can be linked only to other item codes, and customer codes only to other customer codes.

Analysis code linking uses OR logic. For example, if code ABC links A, B, and C, any customer meeting the criteria for A, B, or C is included in ABC.

Link analysis codes in Analysis Code Link Maintenance (1.8.7).

Fig. 3.8
Analysis Code Link Maintenance (1.8.7)

Type. Valid values are item or customer.

Code. Enter a valid analysis code. This code is considered the parent.

Linked Code. Enter the code you want to link to. This code is considered the child.

Description. Enter a brief description of this link.

You can view analysis code links in two ways.

- Use Analysis Code Link Inquiry (1.8.8) to view codes linked to a parent code.
- Use Analysis Code Where-Linked Inquiry (1.8.9) to view child analysis codes and the parent codes they are linked to.

Building Analysis Codes

Use Analysis Code Detail Build (1.8.19) to build a table of items or customers for each analysis code, based on analysis code rules and links previously defined. Build analysis codes whenever these rules or links are changed, when new codes are created, and when new items and customers are created.

When you execute this program, the system displays a message listing the number of nodes exploded and the execution start and stop time.

Note Although builds can be run online, batch mode may be more efficient due to potentially long run times.

Pricing Control (1.10.1.24) gives you the option to automatically build analysis codes when you add new customers and items or make changes to existing customer and item records. However, if you change condition fields for an analysis code, you must still run the build program. This utility builds the data by analysis code type.

Warning Interrupting this utility can disable price lists that use analysis codes. This utility must be completed in its entirety.

As the build proceeds, the system displays:

- *Process Started.* Date and time the program was initiated.
- *Nodes Exploded.* Current number of items or customers processed.
- *Elapsed Time.* Time it took for the system to update each item or code.

- *Process Stopped.* Time the program completed.

At the end of the build, the system generates a summary report, listing the analysis code type, code value, active status, and each customer or item selected by the build.

Detailed Selection of Analysis Code Nodes

Use Analysis Code Detail Maintenance (1.8.13) to inactivate or reactivate individual items and customers selected for a code. An asterisk in the Sel field indicates an active node. Navigate to the item or customer you want to modify. Then press Enter to toggle its current state.

Fig. 3.9

Analysis Code Detail Maintenance (1.8.13)

Sel	Node	Description
	FG100	Finished Good 1
*	FG200	Finished good 2
*	FG300	Finished Good 3
*	FG400	Finished Good 4

Sel	Node	Description
	FG100	Finished Good 1

To select a node by name, click Next to access the update frame at the bottom of the screen. You can type the first character of the node name to go directly to its location in the list of nodes.

Note A deselected node can only become active again by being selected in this program. Running Analysis Code Detail Build has no effect on its status.

Viewing Analysis Code Nodes

There are two inquiries for viewing analysis code nodes:

- Use Analysis Code Detail Inquiry (1.8.14) to view specified analysis codes and their nodes.
- Use Analysis Code Where-Used Inquiry (1.8.15) to view the analysis codes to which a specified node belongs.

Copying Analysis Codes

Use Analysis Code Copy (1.8.20) to copy an existing analysis code as a basis for creating a new one.

Fig. 3.10

Analysis Code Copy (1.8.20)

Type. Enter Customer or Item.

Code. Enter the analysis code to be copied.

To. Enter the name of the new analysis code.

Setting Up Item Price Break Categories

Price break categories let you assign volume price breaks for multiple items. Discounts can be calculated based on the quantity or amount ordered on multiple lines of a sales order or quote.

Example One hundred green bicycles are ordered on line 1 of a sales order, 100 red bicycles on line 2, and 200 bicycle reflectors on line 3. The reflectors receive a price break based on the quantity of bicycles ordered (200)—not the quantity of bicycles plus reflectors (400). The bicycles also receive a price break based on the number of bicycles ordered (200).

Fig. 3.11
Cumulative Price Break Categories

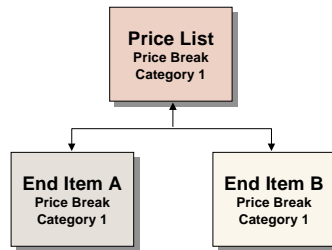

There are two ways to take advantage of price break categories:

- Accumulate quantities on related items by assigning the same price break category to each item.
- Offer discounts on accessory items by assigning a price break category to a price list to which the accessory item belongs and to the item master of the accessory item's principal item.

Note An item that qualifies for a price list but does not belong to a price break category receives the price or discount associated with the price list. The price or discount is based on the accumulated quantity of the line items that belong to the price break category. This is illustrated in the following example.

Example Price list A specifies a discount of 25% on a quantity (total items) of 100. The sales order items are as follows:

- Line 1 reflectors, Qty = 25
- Line 2 bells, Qty = 25
- Line 3 streamers, Qty = 25
- Line 4 horns, Qty = 25
- Line 5 tires, Qty = 2
- Line 6 seats, Qty = 1

Price list A has a price break category of Accessories. Reflectors, bells, streamers, and horns belong to price break category Accessories. Tires and seats do not belong to this price break category but do qualify for price list A. All line items receive the discount of 25% from price list A since the quantity of the items that qualify for the break category equals 100 (the total of pumps, bells, streamers and horns is 100).

Enter break categories in Item Master Maintenance (1.4.1) and Price List Maintenance (1.10.1.1).

Fig. 3.12
Price Break Category Field of Item Master Maintenance (1.4.1)

Item Number. Enter an item code.

Price Break Category. Enter a category name. Name price break categories as you like, but make sure that you enter the same names on price lists and other items.

Creating and Maintaining Price Lists

A price list defines all the information necessary to correctly price an item for a customer. A price list applies to the customer or item codes you assign to it as follows:

- A single item number
- A single customer number
- A group of customers belonging to an analysis code
- A group of items belonging to an analysis code
- All customers

The discount type, referred to as the *amount type*, defines the purpose of a price list. There are several discount types, and they can be combined. A price list also defines minimum quantities, effective dates, and other information you may want to extend to your customers.

See “Discount Types” on page 67.

When an order is entered, the system determines which price lists apply, examines those lists, and determines which of them yield the best price for the order. Applicable price lists may have been determined using the same or different criteria.

See “Calculating Best Prices” on page 70.

Discount Types

The Amount Type field determines the discount type assigned to a price list. Possible choices are:

- *List Price.* Used as the item list price. List prices also set allowable minimum and maximum prices, if selected for a given line item, even if the list price is manually overridden.

List prices are the foundation of pricing logic. The choice of exclusive, base, combinable, and base combinable as the Comb Type does not apply to list prices. They must be set up with a Comb Type of combinable.

- *Discount%.* Percentage subtracted from the item list price.
- *Discount Amt.* Amount subtracted from the item list price.

- *Markup*. Percentages added to item cost in a specified cost set. Must be either a base or exclusive combinable type.
- *Net Price*. Discounts resulting in a fixed price. Must be either a base or exclusive combinable type.
- *Accrual*. Similar to Discount%, except that a percentage of the net price accrues to a specified general ledger account, without reducing the net price, and independent of discount.
- *Credit Terms*. Specified for an order or quote, independent of other discount types.
- *Freight List*. Specified for an individual order or quote line item, independent of discount.
- *Freight Terms*. Specified for an order or quote, independent of discount.

Other Pricing Elements

The system processes pricing by line item. As a sales order or quote is entered, the system determines the following:

- Who the pricing customer is
- Which price lists combine with other price lists
- Which price lists are candidates for each line item
- Whether break category discounts apply
- Whether configured products are included, and whether pricing applies across the entire product or at the current level only
- Which price list yields the best overall price for the customer

Who Is the Pricing Customer?

When selecting price lists, the system determines who the pricing customer is as follows:

- When sales orders are entered, the system uses the customer number in the Ship-To field as the pricing customer if the ship-to customer is defined in the customer master.
- Otherwise, the system uses the customer number in the Sold-To field as the pricing customer.

Discount Combinability

The best possible new price of a line item is determined by considering multiple discounts and combining various discounts. Combination types instruct the system how price lists combine with other price lists for purposes of multiple discounts and best pricing calculations. The choices are:

- *Base*. The standard discount for customers that serves as the basis for additional discounts and can be combined with any non-exclusive price list. Base price lists are exclusive of other base price lists.
- *Combinable*. Incremental price lists intended to combine with base and other combinable price lists.
- *Base-Combinable*. Incremental price lists intended to combine base price lists only.
- *Exclusive*. Exclusive price lists that cannot be combined with any other price lists.

The best discount the system arrives at is one of the following: best base price plus all combinable discounts, best base price plus the best base combinable price list, and the best exclusive price list.

Markup and net price lists must be of combination type base or exclusive.

List price tables provide pricing history and set minimum/maximum prices. They are the foundation for the pricing logic. For pricing structures with an Amount Type of list price, the combination type does not apply. They must be set up with a Comb Type of combinable.

Price List Candidates

The system finds candidates by matching the customer number and the item number on a sales order with the customer code and the item code on the price lists. A match is found if *all* of the following conditions are true:

- Customer code on the price list equals:
 - The customer entered on the order
 - Any customer analysis code associated with this customer
 - Blank, indicating the price list applies to all customers
- Item code on the price list equals:
 - The item number entered on the order
 - Any item analysis code associated with this item number
 - Blank, indicating the price list applies to all items
- The order currency and price list currency are the same.
- The start and end dates are effective.

Break Categories and Price List Processing

As each line item is priced, the system determines if any lines need to be accumulated for price breaks. If so, the price calculated is based on the total quantity (or amount) on all qualifying line items.

A line qualifies if the item break category matches:

- The break category on a selected price list, *and*
- The break category of another line item on the same order.

Once all line items are completed, the system reviews them to ensure that proper discounts are calculated. For example, if line item 4 affects the quantity discount for a prior line, the system reviews that line and updates its pricing. There may be times when an item should receive a discount based on the quantity ordered on other line items, but should not add to the total break quantity.

See “Other Pricing Elements” on page 68.

Configured Products Pricing

The system determines in two stages whether price lists apply across an entire configured product line or at the current level only.

Factor contestants. Each component, including the parent item of the configured product, is priced independently and then totaled.

Best overall price. The system calculates the net price for the entire configured item, using the rolled-up list price, discounted by only those discounts that apply across the entire configuration.

The system then compares the net price with the best overall net price and chooses the better of the two.

Calculating Best Prices

In best pricing, multiple discounts are considered and applicable discounts combined to determine the best possible net price for a line item, as illustrated in Figure 3.13.

Fig. 3.13
How Best Pricing Works

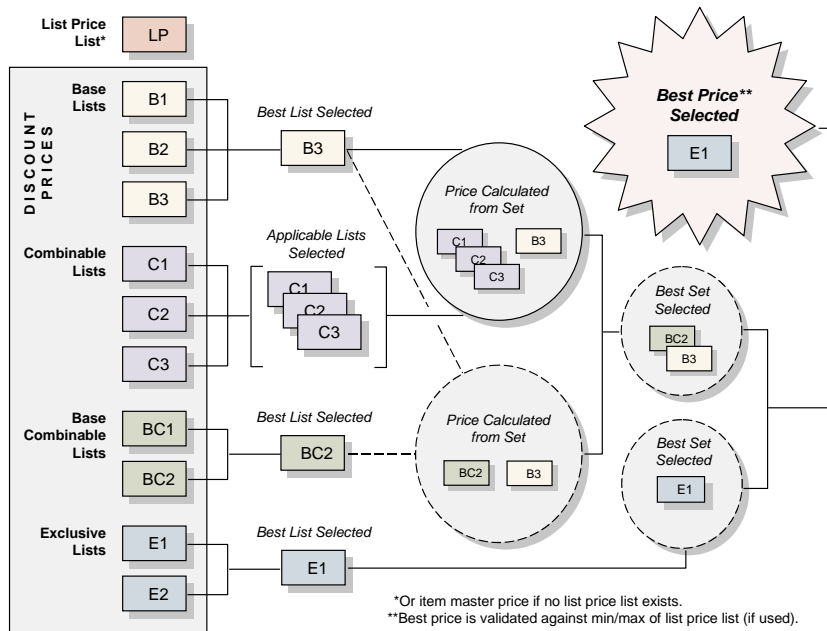

Multiple price lists may apply. The best discount is:

- The best base price plus all combinable discounts, *or*
- The best base price plus the best base-combinable price list, *or*
- The best exclusive price list

When the system has found all qualifying price lists, it then determines what combinations result in the best price. The rules for combining price lists are based on the Comb Type field in Price List Maintenance. Table 3.3 lists how the system uses price lists.

Table 3.3
How Price Lists Are Used

System Function	What happens
Building the Best List Price	The system evaluates each applicable List Price price list. If more than one is found, the lowest price is used. If no List Price list is found, the Price field from the Item Master Maintenance is used. The price is stored in the List Price field of the sales order or quote.
Building the Best Net Price	The system accesses each applicable Discount%, Discount Amt, Markup, and Net Price price list. It then determines what combination yields the lowest price. The rules for combining price lists are based on the Com Type field in Price List Maintenance. The Discount and Net Price fields are then updated on the sales order or quote.
Modifying Price for Minimum or Maximum	If the calculated Net Price on a sales order is above the maximum or below the minimum price (set on List Price price lists in Price List Maintenance), the Net Price on the sales order or quote is adjusted.
Manually Overriding Calculated Prices	The calculated List Price, Discount, and Net Price can be manually changed on a sales order or quote (if you have security access to these fields). When this occurs, the system records a Manual discount, which is the difference between the system-generated price and the price entered.

Example A company offers a promotional discount to customers in a geographic area. For qualifying customer A, this discount is better than the standard discount. Qualifying customer B, however, qualifies for a better discount than the geographic discount. The system assigns the better discount, so customer B is not penalized for qualifying for the promotion.

Discount Sequences

When using combinable type discounts, the discounts can either be added together or multiplied/cascaded. Specify which calculation to use in Pricing Control for all orders and price lists.

Note A discount is combinable when more than one price list is used to determine net price.

When the cascading calculation method is chosen and GL accounts are used to track discounts to individual price lists, the discount sequence number becomes important. This is because the individual discount amounts can differ depending on the order in which they are applied. The net price of the order is the same regardless of sequence numbering.

When the additive calculation method is used, discount sequence number is not significant. With this method, the calculation uses the best list price with each discount and adds the individual discount amounts to obtain the total discount.

Applying the Additive Method

In a sales order line with a best list price of \$100, price lists A and B are used. Price list A has a sequence number of 100 with a 20% discount. Price list B has a sequence number of 200 with a 30% discount. Using the additive method, the system calculates the discounts as follows:

$$\$100 * .20 = \$20$$

$$\$100 * .30 = \$30$$

$$\$20 + \$30 = \$50$$

A discount of \$20 is recorded for price list A and \$30 for B. The total discount is \$50 and the net price is \$50. It does not matter which discount is calculated first, because the best list price is used to calculate both individual discounts.

Applying the Cascading Method

Using the cascading method for the same example, the system first performs the calculations for price list A, since it has the lower sequence number:

$$\$100 - [\$100 \times (1-.20)] = \$20$$

$$\$100 - \$20 = \$80$$

Calculations are then performed for price list B:

$$\$80 - [\$80 \times (1-.30)] = \$24$$

$$\$80 - \$24 = \$56$$

The total discount for the order is \$44 and the net price is \$56. For this order line, a discount of \$20 is posted in the general ledger for price list A, and \$24 for B.

Note If a manual price list is included in the pricing determination, the system assigns it sequence 999. This ensures that manual discounts are calculated last when the cascading method is used.

If the sequence numbers are reversed, calculations are first performed for price list B:

$$\$100 - [\$100 \times (1-.30)] = \$30$$

$$\$100 - \$30 = \$70$$

Calculations are then performed for price list A:

$$\$70 - [\$70 \times (1-.20)] = \$14$$

$$\$70 - \$14 = \$56$$

As before, the total discount is \$44, and the net price is \$56. But the discount posted for price list A has changed from \$20 to \$14; and the discount for price list B has changed from \$24 to \$30.

When Discount Sequence Numbers Are the Same

It is possible for two or more price lists to have the same sequence numbers. In this case, the discount is proportioned between the two lists according to the contribution of each. The calculation involved for each price list is as follows:

$$(1 - \text{individual discount factor}) / \text{total additive discount} \times \text{list price} - (\text{list price} \times \text{total cascading factor})$$

The discount factor = 1 – discount percent. Following the previous example, the discount calculation for price list A would be:

$$\text{Discount factor} = 1 - .20 = .8$$

$$\text{Discount} = (1 - .8) / .5 \times \{ \$100 - [\$100 \times (.7 * .8)] \} = \$17.60$$

The individual discount for price list B would be:

$$\text{Discount factor} = 1 - .3 = .7$$

$$\text{Discount} = (1 - .7) / .5 * \{\$100 - [\$100 \times (.7 * .8)]\} = \$26.40$$

The discount calculation works the same with a negative discount.

See “Applying the Additive Method” on page 71.

Creating a Price List

Use Price List Maintenance (1.10.1.1) to define item codes, customer codes, discounts, and other information pertaining to a price list. Create as many price lists as you need to satisfy your pricing requirements. If you do not use price lists, the system uses the Price field in the item master.

Fig. 3.14
Price List Maintenance (1.10.1.1)

Price List. Enter a code identifying the price list.

Customer/Analysis Code. Enter a customer address code, analysis code, or leave blank for all customers.

Item/Analysis Code. Enter an item number, analysis code, or leave blank for all items.

Currency. Enter the code indicating the currency for this price list. The default is the base currency.

Unit of Measure. Enter a unit of measure or leave blank for all units of measure.

Start. Enter the first day this price list is effective. The date must be greater than or equal to the start date. Blank implies there is no expiration date.

When determining which price list to use, the system selects price lists with undefined start/expiration dates before price lists with defined start/expiration dates.

Expire Date. Enter the last day this price list is effective. The date must be greater than or equal to the start date. Blank implies there is no expiration date.

When determining which price list to use, the system selects price lists with undefined start/expiration dates before price lists with defined start/expiration dates.

Proceed to the next frame.

Description. The description of your price list (optional).

Amount Type. The choices are Accrual, Credit Terms, Discount%, Discount Amt, Freight List, Freight Terms, List Price, Markup, and Net Price. The amount type of the list affects which fields display in the following frames. See “Discount Types” on page 67.

Quantity Type. Specify the type of quantity to be used in determining quantity breaks in the price list detail, as well as the way the system uses the value in the Minimum Order field.

- **Quantity:** the price breaks are determined by the number of items ordered. If the cumulative order quantity for an item is less than Minimum Order, the order entry program displays a warning message following line-item entry.
- **Amount:** the price breaks are determined by the total extended list price of items ordered, measured in the price list currency. If the total order amount is less than Minimum Order, the order entry program displays a warning message at the trailer.

Note When using price lists with quantity type amount and the minimum amount is greater than zero, the best list price for the item must also be greater than zero. If the best list price for the item is equal to zero, the price list will not be selected for the order line item.

Set list prices for items in Item Master Maintenance or Price List Maintenance.

Comb Type. This field describes how price lists combine with other price lists for multiple discount and best pricing calculations. Valid values are:

Note Markup and net price lists must be of combination type base or exclusive.

- **Exclusive.** Cannot combine with any other price list.
- **Base.** Can combine with any price list that is not exclusive or another base.
- **Combinable.** Identifies an incremental price list that is intended to combine with other combinable and base price lists. List price tables must be combinable.
- **Base-Combinable.** Identifies an incremental price list that is intended to combine only with base price lists.

See “Discount Combinability” on page 68 for details.

Minimum Order. Specify a minimum quantity or currency amount to be enforced during order entry when this price list is selected. Use of this field depends on the value of Quantity Type.

- **Quantity:** Specify the minimum order quantity that should be allowed on an order that selects this price list. When you enter an order, the system compares the cumulative line quantity of each item with this field. If the order quantity is less, a warning displays. Additionally, in Sales Order Maintenance only, if you choose to continue ordering a below-minimum quantity, the system may prompt you to enter a reason code. This occurs when Keep Booking History is Yes in Sales Order Control.
- **Amount:** Specify the minimum currency amount that needs to be on an order to use this price list. If a price list is selected for an order, this amount is compared with the total order amount. If the Minimum Order value is greater, a warning displays at the order trailer.

Note Even when a warning displays, the price list is still applied to the order. The warning lets you know that minimum requirements have not been met. You can then decide if this appropriate for your needs.

Max Quantity. In conjunction with Quantity Type specified, either the maximum order item quantity or maximum order currency amount allowed for price list; default is 0 (zero).

Break Cat. In conjunction with specified Min Net Ord value, an additional category by which item quantities or currency amounts can accumulate for required price list minimum. Enter blank if you aren't using break categories. Otherwise, enter the item master break category code associated with the item being priced or the break category code assigned to another item. The default is blank.

Config Disc. Either Yes or No. Applicable to configured products. If Yes, the price list applies to everything in a configured product, when pricing a configured item (otherwise ignored). If No, it only applies to the specific item.

Manual. Enter Yes if this price list should only be considered during line item pricing when it is specified in the Manual price list field. Enter No if this price list should be considered anytime it applies to the customer or item.

Max Orders. Defines the maximum number of orders that can be priced using this list for a given customer. This field is for reference only. It is normally used with manual price lists, which might, for example, apply only once for a new customer.

Disc Sequence. In conjunction with Comb Type specified, a numerical value indicating the order in which the system applies price list discounts relative to other price list discounts with which it can be combined; default is 10.0. A discount sequence can be decimal. The system applies lower numbers first.

Print. Enter Yes if the price list should be shown on associated sales order documents and invoices; otherwise, enter No. The default is Yes.

Promotion Type, Promotion. These fields are not currently used.

Cost Set. Applicable cost basis for markup price lists only. Either blank if standard cost or the current cost set associated with the item being priced; default is blank.

Comments. Enter Yes to review or update remarks related to this price list.

Depending on the amount type of the price list you are editing, the system displays a different frame. Figure 3.15 illustrates the frame that displays when the amount type is Credit Terms, Freight List, or Freight Terms.

Fig. 3.15
Price List Maintenance (1.10.1.1), Min Qty and Credit Terms Fields

The screenshot shows a software interface with two input fields. The first field is labeled 'Min Qty:' and contains the value '15.0'. The second field is labeled 'Credit Terms:' and contains the value '30/60'. There are lines pointing from the text labels 'Min Qty field' and 'Credit Terms field' to their respective input boxes. A small magnifying glass icon is visible next to the '30/60' value.

Min Qty. Enter a quantity or amount. The Min Qty field changes to Min Amt if the Qty Type field is set to amount.

Credit Terms. Choose a credit term. The Credit Terms label changes to Frt Terms or Freight List, depending on your selection in the Amount Type field.

Continue entering values for each quantity or amount break.

The frames illustrated in Figure 3.16 and Figure 3.17 display when amount type is Accrual, Discount%, Discount Amt, Markup, or Net Price.

Fig. 3.16
Price List Maintenance (1.10.1.1), Discount and Accrual Account Fields

Account and Project fields

Discount
Account: 000APDS1
Project:

Accrual
Account: 00070I1
Project:

Discount Acct, Sub-Acct, CC, and Project. For Discount%, Discount Amt, Markup, or Net Price price lists, enter an account code for tracking discount amounts. Sub-account, cost center, and project are optional. This must be a valid, active account of type Standard.

If you do not associate accounts with price lists, discounts are posted to the Sales Discount account specified in the order maintenance program.

For accrual price lists, the label of this field changes to Expense. A percentage of the net price accrues to the account specified in the Accrual Acct field. The Expense account is required and used to balance the credit posted to the Accrual account.

Accrual Acct, Sub-Acct, CC, and Project. These fields apply to accrual price lists only. The account you enter is used to track the accrual amounts in the general ledger. This must be a valid, active account of type Standard.

Proceed to the next frame.

Min Qty. A quantity or amount. The Min Qty field changes to Min Amt if the Qty Type field is set to Amount.

Discount Amount. A discount percentage. The Discount Amount label changes to Markup%, Net Price, or Disc Amt, depending on your selection in the Amount Type field.

Fig. 3.17
Price List Maintenance (1.10.1.1), Min Qty and Discount Amount Fields

Min Qty	Discount Amount	Min Qty	Discount Amount
15.0	2.00		
25.0	5.00		

Min Qty field

Discount Amount field

Min Qty: 50.0 Discount Amount: 10

Continue specifying values for each quantity or amount break.

The frame illustrated in Figure 3.18 displays when amount type is List Price.

List Price. Enter the list price for this price list.

Minimum Price. Enter the lowest allowable price for this price list. If a lower price is entered on a sales order, this price is used instead.

Maximum Price. Enter the highest allowable price for this price list. If a higher price is entered on a sales order, this price is used instead.

When you create a List Price price list, the following fields are ignored: Qty Type, Comb Type, Min Net Ord, Max Qty, Break Cat, Config Disc, Max Orders, Disc Sequence, Print, and Cost Set.

Fig. 3.18
Price List Maintenance (1.10.1.1), List Price, Minimum and Maximum Price Fields

List Price:	0.00
Minimum Price:	0.00
Maximum Price:	0.00

Reviewing Price Lists

To review price lists, use one of the following programs:

- Use Price List Inquiry (1.10.1.2) to review names and summary information on price lists.
- Use Price List Report (1.10.1.3) to review pricing details for each price list.
- Use Price Lists by Customer Inquiry (1.10.1.5) to review price lists sorted by customer code.
- Use Price Lists by Item Inquiry (1.10.1.6) to review price list detail sorted by item code.

Copying a Price List

Use Price List Copy (1.10.1.8) to quickly create new price lists based on existing ones. You can copy a price list into any currency or adjust existing price lists with increased or decreased prices.

The system makes a copy of the source price list under the target price list code with a start date of today. Specific prices (Amount Type List Price or Net Price) are multiplied by the Adjustment Percent and the Cur Conv Factor, then rounded to the specified number of decimal places. Discount and markup percentages are copied as they are in the source price list.

Fig. 3.19
Price List Copy (1.10.1.8)

Price List Copy

Price List Copy: Go To - ACTIONS -

Source Price List: SO2 Target Price List: SO2f

Source Currency: USD Target Currency: FFR UM: UM:

Cust/Supplier Cat: To: To:

Item Cat: To: To:

Start: 04/04/2007 Expire Date: Expire Date:

Adjustment %: 100.00% Curr Conv Factor: Curr Conv Factor:

Round to Two Decimal Places (x.xx) :

Round to Nearest Whole Number (x.00) :

Round to Nearest Ten (x0.00) :

Round to Nearest One Hundred (x00.00) :

Round to Nearest One Thousand (x000.00) :

Clear Target List:

Create Target List:

Merge Lists:

Update:

Print Audit Trail:

Output: Output:

Batch ID: Batch ID:

Source Price List. Enter the code identifying the price list from which the information is copied.

Source Currency. Currency code used by the source price list.

Target Price List. Enter a code identifying the price list to which the information is copied. The target and source price list can be the same. In this case, an ending effective date is added to the source list and a starting effective date to the target list. If the target list is not the same as the source and does not exist, it can be created. If it does exist, it can be either cleared or added to.

Target Currency. Enter the currency for the system to use on the target prices. The source and target currency can be the same—leave blank for the system to default to the source currency. If you are copying from one currency to another, the system calculates and displays a default Cur Conv Factor using the exchange rates effective on the price list start date. The system adjusts prices on the target list using the conversion factor you specify.

UM. Either an item unit of measure to which price list applies or blank if the price list applies for all units of measure; default is blank.

Cust/Supplier Cat. Either the customer code or the customer analysis code for which price list applies, or blank if price list applies to all customers; default is blank.

Item Cat. Either the item code or the item analysis code for which price list applies, or blank if price list applies for all items; default is blank.

To. Either the last value within a range or blank if range is not specified; default is blank.

Start. Start date defaults to today's date and defines the start date for the new pricing structure created by the copy. This field is applied differently by the system in different situations:

- If the source and target codes and currency are the same and the date entered matches the start date currently on the source price list, a new price list is not created. Instead, the existing price list is modified according to any adjustment percentage entered.
- In other cases when the source and target codes and currency are the same, the system uses the start date as the start effective date on the target list and adds an ending effective date on the source list (day before target's start date).
- If the source and target codes are different, the start date is used on the target and the source list is not affected.

Expire Date. Either the last date (MM/DD/YY) target price list is effective or blank if price list is effective any date on or after start date; default is blank.

Adjustment%. Percent (up or down) target price list amounts are to be adjusted relative to source price list amounts. Enter 100.0 for no adjustment or a numerical value indicating percent adjustment is needed. For example, 90 adjusts target price list down 10%; 110 adjusts target price list up 10%. The default is 100.0.

Curr Conv Factor. Enter a conversion factor to use when the source and target price list currencies are not the same. The system calculates and displays a default conversion factor using the exchange rate in effect on the price list start date. If effective exchange rates are not found, Curr Conv Factor defaults to 1. You can modify the conversion factor, if needed. However, the value cannot be 0.

Clear Target List. Enter Yes to delete all other target price lists having same name and attributes or No to not delete other target price lists; default is No.

Create Target List. Enter Yes (the default) to create a new list if one does not exist. When No, a list is not created. If Create Target List is Yes and the list exists, the value of Clear Target List determines if the list is cleared before the copy, or if an end effective date is added to the old prices.

Update. Enter No (the default) and set Print Audit Trail to Yes to print a report of potential changes before they are made. Specify Yes to update price lists based on the parameters specified.

Print Audit Trail. Enter Yes (the default) to print an audit report showing the effect of applying the copy parameters to the target price list. If No, a report does not print.

Output. Enter an output destination for the audit report.

Batch ID. Assign a Batch ID to process the transaction off line.

Generating Pricing Reports

Three pricing reports display information about how the system calculates prices for order lines:

- Pricing What-If Inquiry (1.10.1.13) displays prices based on user-specified input parameters.
- Customer Orders by Price List Inquiry (1.10.1.15) displays the price lists used to price a customer's orders.
- Sales Order Price Inquiry (1.10.1.17) displays pricing details for selected order lines.
- Use Sales Order Pricing Report (7.15.7) to view pricing history records created for each change to an order line's pricing. See "Pricing History" on page 84.

Pricing What-If Inquiry

Use Pricing What-If Inquiry (1.10.1.13) to review what-if pricing scenarios. This inquiry does not apply to configured products with optionally configured components.

Fig. 3.20
Pricing What-If Inquiry (1.10.1.13)

Customer. Enter the customer address code or customer analysis code for price calculation. Leave blank to calculate prices regardless of customer.

Site. Enter the site code for price calculation. Leave blank to calculate prices regardless of site.

Item Number. Enter the item code or item analysis code for price calculation. Leave blank to calculate prices regardless of item.

Order Qty. Enter the number of line items ordered.

UM. Enter the item unit of measure for price calculation or leave blank if price list applies to all units of measure.

Manual. Enter a code identifying a manual price list or leave blank.

Effective Date. Enter the pricing effective date in MM/DD/YY format. The default is the system date.

Currency. Enter the applicable currency for price list calculations and display. The default is the base currency.

Accum Qty. If price list Qty Type is Quantity, enter the number of items for this order. Either Ord Qty value or Break Qty value; default is Ord Qty.

Accum Amt. If price list Qty Type is Amount, the currency amount accumulated for this order. Either Ord Qty * List Price value or Accum Qty * List Price value; default is Ord Qty * List Price.

Show Only Selected. Choose Yes to have the system show only price lists that are selected for use in determining list and net prices. Choose No to have the system show all price lists considered for evaluation of the list and net prices. In either case, a Yes or No appears in the Sel column indicating the system selection process. The default is Yes.

The system calculates the price for the item and customer you selected for each price list that matches the selected item and customer combination.

Viewing Orders by Price List

Use Customer Orders by Price List Inquiry (1.10.1.15) to ensure that a customer does not exceed the maximum number of orders or to see how a price list is used.

Fig. 3.21

Customer Orders by Price List Inquiry (1.10.1.15)

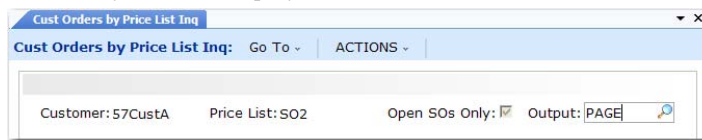

Customer. Enter a customer number.

Price List. Enter a price list that applies to this customer. If you want to see all orders for this customer, leave blank.

Open SOs Only. Yes if you want to see open sales orders only. Choose No if you do not want to limit the inquiry.

Viewing Sales Order Discounts

The system calculates and displays price lists, discount factors, net prices, line item amounts, and order amounts online. After line items have been processed, the system recalculates previous lines based upon quantity breaks if subsequent lines result in a different total accumulated order quantity. To view this information, use Sales Order Price Inquiry (1.10.1.17).

Fig. 3.22
Sales Order Price Inquiry (1.10.1.17)

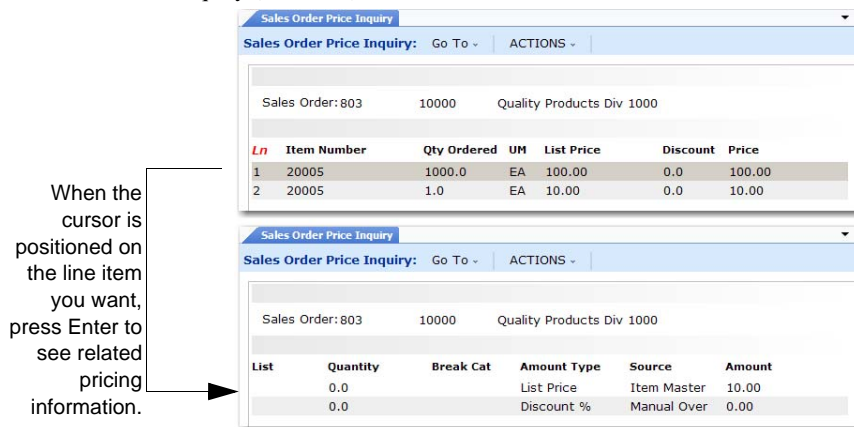

Sales Order. Enter a sales order number, then scroll through the inquiry to display lines on the order. Press Enter on a selected line to see pricing details.

Repricing Orders in Sales Order Repricing

Use Sales Order Repricing (7.1.11) to update the list and net price of selected orders to the latest corresponding price list price. You can reprice sales orders so that ordered quantities are added together, across orders, to calculate quantity breaks.

Note To open a sales order for repricing in Sales Order Repricing (7.1.11), set Fixed Price in the order header or line item to No.

Sales Order Repricing combines orders by matching price lists and any combination of:

- Sold-to customer numbers
- Bill-to customer numbers
- Ship-to customer numbers
- Purchase order numbers
- Any combination of these four factors

Customers that do not have centralized purchasing can still receive quantity and volume discounts based upon purchases made from other intracompany purchasing departments. Line items on combined orders are repriced as if they are on the same order, which means that line items with the same break category (or the same item number) have their order quantities accumulated.

If you want an open sales order to be repriced in Sales Order Repricing, the Fixed Price field in the sales order header or the line item frame must be set to No. Otherwise, the order is skipped, even if it matches selection criteria.

The Fixed Price field appears in:

- Customer Data Maintenance
- Sales Quote Maintenance, header and line
- Sales Order Maintenance, header and line
- RMA Maintenance, header and line

Fixed Price defaults from Customer Data Maintenance to Sales Quote Maintenance, and then to Sales Order Maintenance. If you do not use sales quotes, the value defaults directly from Customer Data Maintenance to Sales Order Maintenance. The value of Fixed Price on an order header determines the default for each line as it is added.

When a sales quote is released to an order, the system resets the Fixed Price value on the order header to the value associated with the customer. The line item Fixed Price value is unchanged.

During order repricing, you can:

- Check credit limits after new prices are applied and make various credit adjustments.
- Print sales orders.
- Combine sales orders.
- Include RMA issues.
- Recalculate taxes.

Use Sales Order Repricing (7.1.11) to reprice and print sales orders and sales quotes for a specified range of order numbers.

Fig. 3.23
Sales Order Repricing (7.1.11)

Use the Sales Order, Sold-To, Bill-To, and Ship-To fields to narrow the range of sales orders to be processed. Leave blank to include all orders. Use the Last Price Date, Order Date, and Due Date fields to select orders to process by date.

Check Credit. Enter Yes to check customer credit limits and past-due invoices, and generate an audit report. Enter No to bypass credit check and generate audit report only; default is Yes. If Yes, you can change the values of related credit check fields.

Print Sales Order. If Yes, the Print field is set to Yes on all orders that are repriced. This allows them to be selected for printing even if they have been printed before.

Set/Clear Action Status. If Check Credit is Yes, enter Yes (the default) to check customer credit status prior to release or No to bypass status check. If Yes, the value of New Action Status is assigned to the Action Status field on the sales order for orders exceeding credit limits.

New Action Status. If Set/Clear Action Status is Yes, leave blank to clear the status, Hd to place on hold, or any other valid status code; default is blank. Make sure that codes are entered consistently by entering the allowed codes into Generalized Codes Maintenance (36.2.13) for field so_stat.

Check Credit Hold. If Yes, the system checks the customer Hold field before clearing the Action Status of an order. If the Hold field is Yes, indicating the customer is on credit hold, the Action Status of orders is not cleared.

Hold Over Credit Limit. If Yes, the system compares the customer balance to the customer credit limit. The customer balance includes open invoices and, optionally, open sales order amounts. If the customer balance is less than the predefined credit limit and the action status is blank, the order is not placed on hold.

Check Past Due Invoices. Used in combination with the Automatically Set Action Status field. If both are Yes, then sales orders for customer with credit problems are automatically placed on hold by setting the action status to the value specified. Otherwise, sales orders are simply listed with all the credit status information

Include Sales Orders. If Yes, the system adds open sales order values to open invoice totals in determining the credit limit. See the description for Hold Over Credit Limit.

Days. The number of days after which the system considers an invoice past due when checking past due invoices.

Amount. The maximum total invoice amount allowed to be overdue after which the system places orders on credit hold for past due invoices.

Combine Sales Orders. If Yes, the system combines sales orders with matching values based on the Yes/No settings in the four Match fields: sold-to, ship-to, bill-to, and purchase order number.

Include RMA Issues. If Yes, the system includes RMA issues in sales order repricing.

Recalculate Tax. Indicate whether the sales tax should be recalculated for the sales orders being repriced.

Use Sales Order Price Inquiry (1.10.1.17) or Sales Quote Price Inquiry (1.10.1.18) to verify if items are priced correctly.

Repricing in Sales Order Maintenance

Sales Order Repricing (7.1.11) reprices a range of sales orders at one time. You can also reprice individual sales orders or lines directly in Sales Order Maintenance (7.1.1).

This kind of repricing is controlled with the Reprice field. Reprice always defaults to No in Sales Order Maintenance and cannot be modified for new orders.

On existing orders, enter No to have repricing only occur when requested for a particular line. This protects orders from inadvertent changes and minimizes the number of times pricing history records are updated.

For existing orders, Reprice has several functions in Sales Order Maintenance. When Reprice is Yes for a line:

- You can update List Price, Discount, and Net Price fields during line item entry.

- If prices were determined automatically, the system automatically recalculates the best price for the item, using current data.
- You can review and modify the bill of material for an existing configured line item. If you change the bill, the cost and price are automatically recalculated.
- You can update the discount account, sub-account, cost center, and project for an existing line item.

Table 3.4 summarizes the effect of the Reprice field on sales order lines.

Table 3.4
Reprice Field Settings and Pricing Updates

Modify Sales Order Line	For lines with manual override price	For lines with automatically calculated price
If Reprice = Yes	1. No automatic calculation. 2. Allow update of price.	1. Recalculate the best price. 2. Allow update of price.
If Reprice = No	No price updating.	No price updating.

Reprice Field and the Sales Order Header

Reprice works differently in the sales order header than in the sales order line. When Reprice is Yes in the header, Reprice is set to Yes for each line and cannot be changed.

Additionally, setting Reprice to Yes in the header lets all order lines be candidates for repricing, even if only one line item is entered or maintained. This is useful where items are similar, have the same break category, or the same item number.

If Reprice is No in the header, you can still reprice at the line level by setting Reprice to Yes for each relevant line.

Repricing and Manual Prices

If you manually specify a price for a line item, the system does not automatically change this price, even if you request repricing. To manually adjust the price again, set Reprice to Yes for the order or the line item. Then you can update the List Price, Net Price, and Discount fields during order entry.

Although repricing a manually priced line never changes the manual entry, it may adjust discounts based on current information. This processing logic supports posting to the intended Sales Discount accounts as identified in price list records. It also enables you to track discount programs in the general ledger.

Pricing History

The system maintains history records for pricing changes. These records detail the source of each price and discount per order/line. Use Sales Order Pricing Report (7.15.7) to view this information.

Pricing history is also maintained for manually entered prices, and gives a complete record of the source (manual or price list) of each price used for a sales order. Using this information, the system preserves manually entered prices even when Reprice is Yes.

Note Pricing history documents the source of the current prices only.

Pricing history ensures that out-of-balance posting to Sales Discount accounts does not occur. When posting discounts to the general ledger, price list history is used, not the difference between list and net, since there can be many discounts, each with different account numbers.

Understanding Sales Order Maintenance Fields

Several fields in Sales Order Maintenance (7.1.1) relate to best pricing.

Fig. 3.24
Pricing Fields in Sales Order Maintenance (7.1.1)

	Details			
Line Pricing	Order Date: 12/12/2006	Line Pricing: <input checked="" type="checkbox"/>	Confirmed: <input checked="" type="checkbox"/>	12/12/2006
Manual	Required Date: 12/12/2006	Manual: <input checked="" type="checkbox"/>	Currency: USD	Language: us
	Promise Date:	Daybook Set: RMJ-DSS1	Taxable: <input checked="" type="checkbox"/>	
Fixed Price	Due Date: 12/12/2006	Channel:	Fixed Price: <input checked="" type="checkbox"/>	
	Perform Date:	Project:	Credit Terms: BASE	
	Pricing Date: 12/12/2006	Site: 2005	Org Inv:	
	Purchase Order:		Credit Terms Interest %: 0.00	
Reprice	Remarks:		Reprice: <input type="checkbox"/>	

Line Pricing. Affects only newly created orders. On existing orders, it defaults to No and cannot be changed. For new orders, it defaults from Price SO by Line in Pricing Control (1.10.1.24). Enter Yes to have the system recalculate price breaks for the order as lines are entered. Enter No to recalculate only once, when order entry is complete.

Manual. Enables you to manually enter a price list code to be considered for order lines. This price list must be set up with Manual set to Yes in Price List Maintenance (1.10.1.1). Manual price lists do not necessarily determine the order line price, but are used in conjunction with other price list search algorithms to determine the best price.

Fixed Price. Sets the default for each line added to the order. Only lines with Fixed Price set to No are updated by Sales Order Repricing (7.1.11). Defaults from the Fixed Price setting defined for the Sold-To address.

This use of fixed price should not be confused with fixed prices as used in service pricing, which enable the customer to be invoiced for a fixed price regardless of the actual cost of items, labor, and expenses recorded.

Reprice. Enter Yes at the order header to have the system reprice modified line items. The system also reprices other line items belonging to the same break category as a modified item. Otherwise, enter No. If No, you can still reprice line items individually in the order detail pop-up window. If Reprice is No on the order header and you enter a new line, the system automatically reprices it. This field only affects the current maintenance session.

Important The value of Fixed Price, not Reprice, determines which orders are repriced by Sales Order Repricing.

Fig. 3.25
Sales Order Line Item Price Fields

Ln	Item Number	Qty Ordered	UM	List Price	Discount	Net Price
1	FL4800	12.0	ea	0.00	0.0	0.00

Line Details

Desc: Electronic Switch
 Loc: 100 Site:
 USD Cost: 0.00
 Lot/Serial:
 Qty Allocated: 0.0
 Qty Picked: 0.0
 Qty Shipped: 0.0
 Qty to Invoice: 0.0
 Salesperson 1:
 Commission 1: 0.00%

Pricing

Pricing Date:
 Credit Terms Int:
 Reprice:
 Price List:
 Perform Date:
 Pricing Date: 04/12/2007
 Multiple:
 Category:

Credit Terms Int: 0.00
 Ship Type:
 UM Conversion: 1.0000
 Consume Fcst:
 Detail Alloc:
 Taxable:
 Freight List:
 Fixed Price:
 Comments:

Pricing Date. This field defaults from the order header. The system uses the pricing date as the effective date in determining prices for this line item. The field is editable only if Vary Pricing Date by SO Line in Sales Order Accounting Control is Yes. When the control program field is No, the Pricing Date of the order header is used and cannot be changed on individual lines. When you update the header, the system automatically changes the date on all lines.

Credit Terms Interest %. Credit terms interest for this line. This field defaults from the header. You can edit the value on individual lines only if Vary Pricing Date by SO Line in Sales Order Accounting Control is Yes. When the control program field is No, the header value is used and cannot be changed on individual lines. When you update the header, the system automatically changes the Credit Terms Interest % field on all lines.

Reprice. Editable only if Reprice is No in the order header. In this case, you can select individual line items for repricing. When set to Yes for a line, the List Price, Discount, and Net Price fields can be edited, and if the original price was calculated by the system, it is automatically recalculated.

Manual. Defaults from the Manual field in the sales order header. You can specify a different manual price list for this line, as needed. This field only has effect if Reprice is Yes.

Fixed Price. Initially defaults from the order header, but can be unique for each line. Determines whether this sales order line is considered by Sales Order Repricing (7.1.11) and whether automatic repricing can occur for this line item in Sales Order Maintenance.

Using List/Discount Table Pricing

List/discount table pricing is used for pricing different kinds of orders other than best pricing, including customer and supplier scheduled orders, purchase orders, and receipts in RMA Maintenance (11.7.1.1).

Each item has a base price expressed in base currency. Price lists are used to store other pricing structures, such as prices in other currencies, prices or discounts for a certain unit of measure, such as a case or full truckload, discounts at different quantity levels, or prices calculated as a percentage markup over GL cost.

Price Lists with Overlapping Dates

When you create, copy, or generate a price list that has the same item, product line, currency, unit of measure, and overlapping dates with an existing price list of the same class (supplier or customer), the system can do any of the following, depending upon how you set start and end dates:

- Expire an existing price list
- Move the start date of an existing price list when you copy or generate a price list.
- Prohibit the copy, creation, or generation of a price list

Note The system does not consider the amount type when determining overlapping dates.

When you copy or generate a price list and the new price list has a start date that is before an existing price list start date and an end date that is earlier than an existing price list end date, the system automatically moves the start date of the existing price list to one day after the end date of the price list you are creating; see Figure 3.26.

Note You cannot create a new price list in the maintenance programs when dates overlap in this manner.

Fig. 3.26
Moving Start and End Dates, Example 1

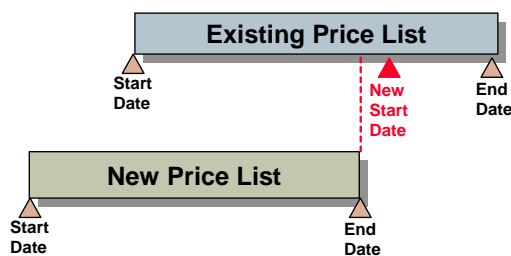

If you copy or generate a price list and the new price list has a start date that is later than the start date of an existing price list, the system automatically expires the existing price list by moving the end date to one day before the start date of the new price list; see Figure 3.27. For this type of overlapping dates, the system prompts you to expire the existing price list in maintenance programs, rather than automatically expire.

Fig. 3.27
Moving Start and End Dates, Example 2

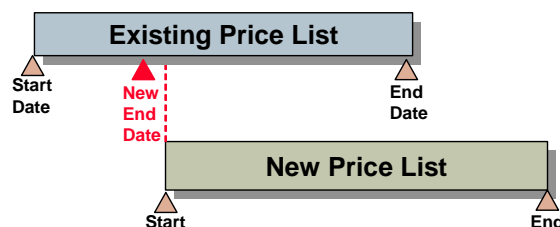

You cannot copy, create, or generate a price list that has a date range that completely surrounds or spans an existing price list date range; see Figure 3.28. If you try, the system displays an error message. However, you can copy, create, or generate a price list that is within the date range of an existing price list; in this case, the system expires the existing price list.

Fig. 3.28
Date Range Not Allowed,
Example 1



Also, you cannot copy, create, or generate a price list if dates overlap with more than one existing price list of the same criteria; see Figure 3.29

Fig. 3.29
Date Range Not Allowed,
Example 2



Price lists that have identical criteria, including one or both dates, but different names are not overlapping price lists. For example you may have two price lists with identical criteria and dates but different names for different suppliers.

Price List Reclassification (1.10.24) displays date validation data in the Message field of the utility reports after you initially run the utility to classify price lists.

See “Changing Price List Classification” on page 99.

Price List Types

Four types of price lists can be defined in Supplier Price List Maintenance (1.10.2.1):

- Type M. Percent markups or markdowns from item GL cost.
- Type D. Percent discounts from item master price.
- Type P. Fixed discount prices, used primarily for net pricing and foreign currency pricing.
- Type L. Multiple list price tables based on minimum and maximum prices.

You can define all but the Type L price lists in Customer Schedule Price List Maintenance (1.10.3.1).

Type D and Type M price lists are discounts that are associated with order quantities. During transaction entry, the system looks for a price list when calculating net item price on scheduled orders or RMA returns and when calculating cost on purchase orders. If an applicable price is not found, either the item master list price is used, or GL cost minus overhead.

Note RMA returns are an exception; if no price is found on the list, the return price defaults to zero.

Use the price list maintenance programs to maintain list and discount price tables. During implementation, use Supplier Price List Generation by Item (1.10.2.6) to create supplier price tables from existing list prices in the item master.

Once price lists are created, you can quickly create lists in other currencies using either Supplier Price List Copy (1.10.2.5) or Cust Schedule Price List Copy (1.10.3.5).

Creating Price Lists

You must define separate price lists using the appropriate menu function:

- Use Supplier Price List Maintenance (1.10.2.1) to set up price lists for POs, blanket orders, purchase requisitions, and supplier scheduled orders.
- Use Cust Sched Price List Maint (1.10.3.1) to set up price lists for customer schedules and RMA receipts.

Note You cannot have the same price list name in both classifications.

When entering an item on an order, the system looks for a matching price list in the following order:

- 1 Currency, price list, item number, unit of measure
- 2 Currency, price list, item number
- 3 Currency, price list, product line (with item number blank)
- 4 Currency, price list (with product line and item number blank)

If no match is found, the item base price displays, converted to the currency of the order.

The system uses price list defaults when you create new orders. Default price lists are derived in different ways, depending on the kind of transaction:

- **Purchase Orders:** Price lists are associated with suppliers in Supplier Maintenance (2.3.1) and provide defaults when purchase orders, blanket orders, and supplier scheduled orders are created.

Discrete POs can have two types of lists—price lists and discount tables—assigned to them. Both types can be defined for the supplier and default to all order types, except supplier scheduled orders. Supplier scheduled orders can only have discount tables.

- **Customer Scheduled Orders:** Price lists are associated with customers in Customer Maintenance (2.1.1) and provide defaults when customer scheduled orders are created.
- **Return Material Authorizations:** A credit price list is associated with warranty and contract types. This price list provides the default in RMA Maintenance (11.7.1.1) and is used for RMA receipt line credits.

Only one price structure can be applied to each order. You cannot set up a price list with base prices in a foreign currency and then access another price list to apply quantity discounts to those foreign currency prices.

You can create price lists and discount tables under the same pricing code. If you do, remember to consider the following. If you create minimum or maximum price ranges, you must ensure that they include any range set on the associated discount table. This is because the minimum and maximum prices on price tables take precedence over discount table prices.

Different price structures can be entered for specific units of measure. This enables you to set up discounts so that if, for example, you buy a case (CS), you get a better price than if you buy only one unit (EA).

Total This Level GL Cost and Total GL Cost are display-only fields. The categories whose elements are included are material, labor, burden, and subcontract. Total GL cost is the total GL cost for the item's default site. It includes all cost elements for this level and lower levels. Total This Level GL Cost is used as the default purchase price. It includes this-level costs, excluding any overhead cost elements. Both purchase and selling prices are for one unit of the item using the item unit of measure.

When you create a new price list, you must specify start and end dates; see Figure 3.30.

Price List Maintenance Programs

Figure 3.30 shows the Supplier Price List Maintenance screen. Field descriptions follow the figure. Fields for Cust Schedule Price List Maint are the same.

Fig. 3.30
Supplier Price List Maintenance (1.10.2.1)

Price List. Enter a code that identifies a pricing structure that defines specific prices, discounts, and markups at different quantity levels.

Type P: Price discount tables can be stated in terms of the domain base currency or any other currency.

Type D: Discount percent prices are discounted from the item list or base price.

Type M: Markup percent prices are percentages added to the item GL cost.

Type L: List price lists enable you to define a base price for the item, rather than using Item Master Maintenance. List type price lists let you enter price changes before their introduction, thus providing a history of an item's price using the Start and Expire dates. You can also set minimum and maximum acceptable prices to use with discount tables to keep the item's price within a certain range.

Note You cannot enter type L price lists in Cust Schedule Price List Maint (1.10.3.1).

Suppliers can be assigned both a price table (L type price lists) and a discount table (D, M, or P type price lists). The prices derived from these tables can be changed on individual order lines.

Description. Optionally enter a description of the price list.

Product Line. Enter the product line associated with this price structure. This field can be left blank. Since each item in the system belongs to a product line, pricing by product line lets you set up price structures for a group of items so that you do not have to enter them individually.

Currency. Specifies the currency of the transactions that are subject to this price list. A price list is used only if the currency of the transaction is the same as the price list currency.

Item Number. Enter an item number if this price applies only to this item. Leave blank to set up price structures by product line or for all items.

Price lists by item are often used to set up foreign currency prices, enabling you to enter a specific base price for an item stated in terms of another currency. This also lets you define different prices at each site. Item prices are also used if you offer special pricing to a customer for only one or a few items, whether specific prices, discounts, or markups.

Supplier Price List by Item Rept (1.10.2.4) and Cust Schedule Price List by Item Rept (1.10.3.4) produce a printed list of item pricing.

UM. Enter the unit of measure associated with this price list structure. This field can be left blank if the pricing applies to any unit of measure. Unit of measure is useful for defining special prices based on the unit of measure of the transaction.

Start. Enter the first date to use for this price structure. You cannot leave this field blank.

You cannot create a price list with dates that fall outside of a current price list date range if the current price list has the same item, currency, product line, and unit of measure.

See “Price Lists with Overlapping Dates” on page 87.

When determining which price list to use, the system compares the transaction date with the price list start and expiration dates. If the transaction date falls on or between these dates, the system selects the price list with the latest start date that has not expired.

Start and expiration dates are useful for phasing in price changes. For example, if you set pricing on a yearly basis, always set the start date to January 1 and the expire date to December 31. Starting the next year, old prices are automatically phased out and new prices used.

Expire. Enter the last date to use for this price structure. You cannot leave this field blank.

If you enter a date that is the same as that for an existing supplier price list with an overlapping same start date and the same item, currency, product line, and unit of measure, the system prompts you to expire the existing price list. If you specify No, you cannot continue. If you specify Yes, the system changes the expiration date on the existing price list to one day before the start date of the price list you are creating.

Amount Type (L/P/D/M). Specify whether the price list is a list price table or discount table:

L: List price table

P: Discount table (net price)

D: Discount table (discount %)

M: Discount table (markup %)

Note You cannot enter a type L in Cust Schedule Price List Maint (1.10.3.1).

The amount type determines which fields display in the next frame. For all amount types, the system displays the following read-only fields:

Item Master List Price. The system displays the price for one unit of the item, using the item stocking unit of measure, at the item's default site.

Total This Level GL Cost. The system displays the total GL cost for the item's default site. It includes all cost elements for this level and lower levels.

Total GL Cost. The system displays the default purchase price. It includes this-level costs, excluding any overhead cost elements.

For lists with amount type L, enter the following:

Price Table List Price. Enter the price or cost for one unit of the item, using the price table unit of measure. This price overrides the item master list price or cost.

Minimum Price/Maximum Price. A range of acceptable values for the line item net price/cost (list price/cost minus any discounts). If the line item net price/cost is outside this range, the system displays an error message.

For lists with amount type P, D, or M, enter a set of minimum quantities and the corresponding price, discount percentage, or markup percentage.

Generating Price Lists by Item

After defining item prices in the item master, you can create supplier price tables automatically using Supplier Price List Gen by Item (1.10.2.6). You can create supplier price tables from item master prices, and you can create prices for one or a range of items and product lines.

Supplier Price List Gen by Item uses only item master list price, not item cost, to calculate the new list price. For supplier price lists, the system creates only type L price lists, using the default item stocking UM as the price list UM. Once the lists are created, use the supplier price list maintenance program to add minimum/maximum prices and change prices.

Figure 3.31 shows the Supplier Price List Gen by Item screen. Field descriptions follow the figure.

Fig. 3.31
Supplier Price List Gen by Item (1.10.2.6)

Item Number/To. Enter a range of item numbers for which price tables are to be created.

Prod Line/To. Enter a range of product lines for which price tables are to be created.

Target Price Table. Assign a price list code to the price tables being created.

Target Currency. Assign a currency code to the price tables being created.

Start. Assign a start date to the price tables being created. You cannot leave this field blank.

You cannot generate a price list with dates that fall expand a current price list date range if the current price list has the same item, currency, product line, and unit of measure.

See “Price Lists with Overlapping Dates” on page 87.

Expire Date. Assign an expiration date for the price tables being created. You cannot leave this field blank. The system applies this field differently in different situations if the target price list is of the same type as an existing price list for the same item, currency, product line, unit of measure, and dates overlap:

- If the target price list has a start date that is earlier than an existing price list start date and an end date that is earlier than an existing price list end date, the system automatically moves the start date of the existing price list to one day after the target end date. See “Price Lists with Overlapping Dates” on page 87.
- If the target price list has a start date that is later than an existing price list start date and earlier than the expire date, the system automatically expires the existing price list by moving the existing price list expire date to one day before the target price list start date.
- If the target list has a date range that completely surrounds or spans an existing price list date range, you cannot generate the list. See page 88.

Target Update Option. Enter one of the following values that determines how the system handles items that already have a target price list.

Skip (the default): Skips the item and does not create a price table for it.

Clear: Deletes the existing Type L price list and creates a new Type L price list.

Expire: Creates a new target price list and sets the expire date of the existing Type L price list to either the:

- Start date minus one day of the date specified in Start Date
- Start date plus one after the date specified in Expire Date

See “Price Lists with Overlapping Dates” on page 87.

Update. If No, the system prints a simulated transaction report. If Yes, the system creates the target price tables.

Copying Price Lists

Use Supplier Price List Copy (1.10.2.5) to quickly create alternate price lists for suppliers from one base price list and automatically recalculate prices based on the Cur Conv Factor. Use Cust Schedule Price List Copy (1.10.3.5) to do the same for customer price lists. You can also adjust existing price lists by increasing or decreasing prices with an adjustment percent.

Figure 3.32 shows the Supplier Price List Copy screen. Field descriptions follow the figure. Fields for Cust Schedule Price List Copy are the same, except for the following:

- Cust Schedule Price List Copy does not have Clear Supplier Price, Create Supplier Price, and the Supplier fields.
- Supplier Price List Copy does not have an Update Item Price field.

Fig. 3.32
Price List Copy (1.10.2.5)

Source Price List. Enter a valid price list code to be used as the source of the data copied to the target price list.

Target Price List. Enter the code to be used as the destination of the copy. Target and source can be the same; however, the system can change dates or prohibit copying when dates overlap. See “Price Lists with Overlapping Dates” on page 87.

Source Currency. Enter the currency of the prices being copied. Pricing information and currency rate from the source price list are copied to the target price list for the range of item numbers specified.

UM. Enter the unit of measure for the item for the source price list. You define the unit of measure in Unit of Measure Maintenance.

Target Currency. Enter the currency for the system to use on the target prices. The source and target currency can be the same—leave blank for the system to default to the source currency. If you are copying from one currency to another, the system calculates and a default Cur Conv Factor using the exchange rate effective on the price list start date. The system adjusts prices on the target list using the conversion factor you specify.

UM. Enter the unit of measure for the item for the target price list. You define the unit of measure in Unit of Measure Maintenance.

Item Number/To. Enter a range of item numbers to be used as selection criteria in choosing prices to be copied.

Start. Enter the start date for the new pricing structure created by the copy. The default is today’s date.

Expire Date. Enter the expiration date as the end effective date for the target price list. The system applies this field differently in different situations if the source and target price list have the same currency, product line, and unit of measure and dates overlap:

- If the target price list has a start date that is earlier than the source price list start date and an end date that is earlier than the source price list end date, the system automatically moves the start date of the source price list to one day after the target end date. See “Price Lists with Overlapping Dates” on page 87.
- If the target price list has a start date that is later than the source price list start date and earlier than the source price list expire date, the system automatically expires the existing price list by moving the source expire date to one day before the target price list start date.

- If the target list has a date range that completely surrounds or spans an existing source list date range, you cannot generate the list. See page 88.

Adjustment %. Specify the adjustment percentage by which prices (Amount Type P) are multiplied, then rounded to the specified number of decimal places. The default is 100%. Discount and markup percentages (Amount Type D and M) are also multiplied by the adjustment percent. If the percentage is greater than 100%, amounts are increased. If the percentage is less than 100%, amounts are decreased.

Cur Conv Factor. Enter a conversion factor to use when the source and target price list currencies are not the same. The system calculates and displays a default Cur Conv Factor using the exchange rate in effect on the price list start date. If effective exchange rates are not found, Cur Conv Factor defaults to 1. You can modify the conversion factor, if needed. However, the value cannot be 0.

Clear Supplier Price. Indicate if supplier prices are cleared before copying in the new prices.

No (the default): Prices are added to the existing supplier-item prices.

Yes: Existing supplier-item prices are cleared and the new prices are added.

Supplier Price List Copy can be used to create supplier-item quotes. Cust Schedule Price List Copy can be used to create customer-item quotes. When Create Supplier Item is Yes, you are prompted to enter a supplier. All adjusted prices are calculated and copied into supplier-item records as the Quote Cost for that supplier. Quote prices are accessed by purchasing to display the current price quoted by a supplier. Other supplier-item information is also available but must be adjusted manually.

Clear Target List. Indicate if the target price list should be cleared before copying the new prices.

No (the default): The system adds the prices to the existing target price list.

Yes: The system clears the target price list first and then copies the new prices.

Update Item Price. Indicate if the item base price should be adjusted during this process.

Note This field displays in Cust Sched Price List Copy (1.10.3.5), not in Supplier Price List Copy (1.10.2.5); see Figure 3.33 on page 96.

No (the default): Item base prices are not affected.

Yes: The base price for the item is set to the target price. Two other conditions must be true: the source price list must have a P or L amount type, and the target price list currency must be the base currency. Each item number on the price list is updated with the first price on the price list.

Create Supplier Item. Indicate whether the system creates a supplier price list if it does not exist. If this is Yes, a new price is created if one does not exist. If this is No, a list is not created. If Create Supplier Item is Yes and the price exists, the value of Clear Supplier Price determines if the price is cleared before the copy, or if an end effective date is added to the old price.

Create Target List. Indicate if the supplier item price does not exist, it should be created.

No: A new price list is not created.

Yes (the default): A new price is created if one does not exist. The system copies the price list by expiration date and unit of measure that matches the list name, currency, and unit of measure. If the source is an amount type M, the target is also a type M.

If Create Supplier Item is Yes and the price exists, the value of Clear Supplier Price determines if the price is cleared before the copy.

Supplier. Enter the supplier for whom you want to update item quotations.

The price list copy function can be used to create supplier-item quotes. When Create Supplier Item is set to Yes, you are prompted to enter a supplier code. All adjusted prices are calculated and copied into the Supplier Item table as the Quote Cost for that supplier.

When Clear Supplier Price is No, the system adds the quote prices into the existing supplier item table. When it is Yes, the system clears the data and then copies in the new prices.

Quote prices are accessed by purchasing, to display the current price quoted by a supplier. Other supplier-item information is also available but must be adjusted manually--Quote Qty and Lead Time.

Round to Two Decimal Places, Round to Nearest Whole Number, Round to Nearest Ten, Round to Nearest One Hundred, Round to Nearest One Thousand. Set only one of these to Yes, indicating the rounding method to be used when creating the new price list structure.

Update. Indicate if the target price list is actually updated based on the parameters specified. It is recommended that you set Update to No and Print Audit Trail to Yes to create a report of potential changes before they are made. This lets you review changes before actually creating or updating the target price.

No (the default): A report runs but the update does not occur.

Yes: Target price lists are updated based upon the parameters you set.

Print Audit Trail. Defaults to No. Indicates if an audit report should be printed. If Yes, a report prints showing the effect of applying the copy parameters to the target price list. If No, a report does not print.

Fig. 3.33
Cust Schedule Price List Copy (1.10.3.5)

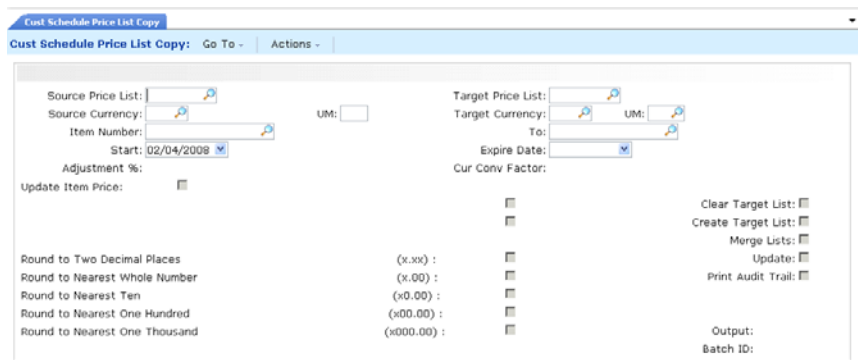

Processing List/Discount Prices

Use list/discount price tables for purchasing, scheduled orders, and some service transactions.

Note You cannot enter a type L price list on customer scheduled orders.

The following example shows how they are used on purchase orders, but the process is similar for other transactions.

When entering an order, the Price Tbl and Disc Tbl fields display in the header. These fields record the price table and discount table code for the transaction. Values for both default from the supplier, but you can override them if necessary. Using control program options, you can require users to enter price and discount tables.

Purchasing Control Settings

Use Purchasing Control (5.24) to indicate if discount tables are required for discrete purchase orders, blanket orders, and supplier scheduled orders. Set appropriate values for the following fields:

Price Table Required. This field determines how strictly price lists are used to control order entry.

No: Items can be entered whether or not a price list exists.

Yes: Only items from an existing price list can be entered, and only if the price list item, unit of measure, and currency match the order item, unit of measure, and currency exactly.

In searching for a valid price, blank is *not* considered a match. If price lists are set up with a blank item or unit of measure, a price is never found. If you are pricing by product line, this field should be set to No.

Prices can be overridden unless the field is protected through security.

Discrete Discount Table Req. Indicate whether discount tables are required for items you enter on discrete or blanket purchase orders. By requiring discount tables you can control:

- Which items can be purchased or ordered from customers or suppliers
- The unit of measure for the items, such as case quantities

No (the default): You can enter items on discrete or blanket orders regardless of whether a discount table exists.

Yes: You can only enter items on discrete or blanket orders from an existing discount table when ordering or purchasing. The price, item, unit of measure, and currency on the order must exist on the price list.

Note Even when this field is Yes, you can still enter a memo item without a matching price. In this case, a warning displays rather than an error.

You can override prices on discrete or blanket orders as long as you have the appropriate security applied to the Price field.

Schedule Discount Table Required. Indicate whether discount tables are required for items you enter on supplier scheduled orders. By requiring discount tables you can control:

- Which items can be purchased or ordered from customers or suppliers
- The unit of measure for the items, such as case quantities

No (the default): You can enter items on scheduled orders regardless of whether a discount table exists.

Yes: You can only enter items on scheduled orders from an existing discount table when ordering or purchasing. The price list, item, unit of measure, and currency on the order must exist on the price list. Even when this field is Yes, you can still enter a memo item without a matching price. In this case, a warning displays rather than an error.

You can override prices on scheduled orders as long as you have the appropriate security applied to the price field.

Note The Schedule Discount Table Required field was added as part of the ADG Scheduled Order Enhancements project.

You can view the Purchasing Control settings for required discount tables for either purchase or scheduled orders using Control Tables Report (36.17.6).

Sales Order Control Settings

Use Sales Order Control (7.1.24) for customer scheduled orders. Enter the appropriate values for the Discount Table Required field.

Discount Table Required is similar to both the Discrete Discount Table Req field except that it determines whether discount tables are required for items you enter on customer scheduled orders.

See page 97.

Price Calculation

To calculate the net cost, the system does two things:

- From the price table, it selects the unit cost for the line item due date or the order entry date, depending on what you specified in Purchasing Control. If pricing is by item due date, the due date defaults from the due date in the order header, but you can override it for individual lines from single-line entry mode.
- If a discount table is specified, the system applies the percentage from the discount table for the line or order due date to calculate the extended net cost for the line item quantity. You can override this net cost manually.

If the price table has a minimum or maximum cost, the system verifies the calculated or user-entered net price against it. If the net cost is outside the minimum/maximum range, the system displays a warning message and replaces the line item net cost with either the maximum or minimum price from the price table, as appropriate.

When entering an item on an order, the system looks for a matching price list in the following order:

- 1 Currency, price list, item number, unit of measure
- 2 Currency, price list, item number
- 3 Currency, price list, product line (item number blank)
- 4 Currency, price list (product line and item number blank)

In addition, for a price list to be used:

- The currency of the order and price list must be the same.

- The order date must be within the pricing effective dates.

If no match is found, the item base price displays, converted to the currency of the order.

Displaying Price List Data

Table 3.5 lists reports and inquiries you can use to view or track price list and price list changes.

Table 3.5
Price List Reports/Inquiries

	Report/Browse	Description
Supplier	Supplier Price List Browse (1.10.2.2)	Display price lists for suppliers
	Supplier Price List Report (1.10.2.3)	Display price lists for suppliers by price list, product line, item number, currency, or effective date.
	Supplier Price List by Item Rept (1.10.2.4)	Display supplier price lists by item by product line, item number or type, product group, the date the item was first added to the system, or the pur/mfg code for the item. You can also display by price list, currency, or effective date.
Customer	Cust Sched Price List Browse (1.10.3.2)	Display price lists for customer schedules and RMA receipts.
	Cust Schedule Price List Report (1.10.3.3)	Display price lists for customer schedules, POs, blanket orders, purchase requisitions, and RMA receipts by price list, product line, item number, currency, or effective date.
	Cust Schedule Price List by Item (1.10.3.4)	Display customer schedule or RMA receipt price lists by item by product line, item number or type, product group, the date the item was first added to the system, or the pur/mfg code for the item. You can also display by price list, currency, or effective date.
	Master Audit Report (36.17.1)	Runs a report that lists changes to price lists, including the price list classification (supplier or customer schedule) and lists price lists as unclassified if you did not run Price List Reclassification.

Changing Price List Classification

Use Price List Reclassification (1.10.24) to assign or change a price list

Use this utility carefully if you need to retain historical price list information. You should assign menu-level security to the utility. Reclassifying a price list name reclassifies all instances of that name; for example, if you have price lists by month for a single price list name, the system reclassifies all instances of the price list, even those with past dates. The system does not check for price lists on open orders before reclassifying.

You can optionally indicate whether you want to classify price lists assigned to customer or supplier addresses. You cannot reclassify a price list that is assigned to both a customer and a supplier address. If the system finds a price list that is assigned to both a customer and supplier address record, all instances of that price list remain unclassified, and the system displays a message that indicates a dual duty price list.

You cannot reclassify a type L supplier price list as a customer price list. If you try, the system reports an error.

To assign a classification to a single price list, specify the name in Price List and the classification in New Classification.

If you set Unclassified Price List to Yes, the system assigns the new classification to any price list not assigned to a customer or supplier address. Use the Unclassified Price List field with the Price List field to narrow your selection criteria.

You can run the utility with Update set to No to preview price list changes, then set Update to Yes to make the changes. The system reports price lists that it cannot change; for example when a list is assigned to both customers or suppliers.

Fig. 3.34
Price List Reclassification (1.10.24)

The screenshot shows a software window titled "Price List Reclassification". The window has a menu bar with "Go To" and "Actions". The main area contains the following fields and options:

- Supplier Address Price Lists:
- Customer Address Price Lists:
- Price List:
- Unclassified Price Lists:
- New Classification:
 - 1 = Supplier
 - 2 = Customer Schedule
- Update:
- Output: Batch ID:

Supplier Address Price List. Indicate Yes or No to change classification for all price lists assigned to a supplier address.

No: The system does not select price lists assigned to supplier addresses.

Yes: The system selects all price lists assigned to supplier addresses and reclassifies them as customer schedule price lists. When Yes, you cannot enter a name in Price List.

Customer Address Price List. Indicate Yes or No to change classification for all price lists assigned to a customer address.

No: The system does not select price lists assigned to customer addresses.

Yes: The system selects all price lists assigned to customer addresses and reclassifies them as supplier price lists. When Yes, you cannot enter a name in Price List.

Price List. Optionally specify a price list name to reclassify only that price list. The system assigns the classification to all price lists of that name. If the price list is currently classified, the system looks for price lists with the opposite classification specified in New Classification.

Unclassified Price List. Optionally select only price lists that have no current classification. If either Customer Address Price List or Supplier Address Price List is Yes, you cannot access this field.

No (the default): The system ignores unclassified price lists.

Yes: The system assigns the new classification to only unclassified price lists. If you specified a price list by name, the system looks for unclassified lists by that name.

New Classification. Specify the price list classification to apply to the price lists that meet the selection criteria:

1: Supplier

2: Customer Schedule

Update. Indicate whether to update the price lists that meet the selection criteria to the classification specified in New Classification.

No: The system generates a simulation report of the price list records that would be updated when you run the utility.

Yes: The system updates the price lists records to the new classification and prints a report showing the changes and any exceptions.

Product Change Control

Product Change Control (PCC) lets you control and monitor product changes. Approval cycles let you control how and when suggested changes are incorporated into your production tables.

Introduction to PCC 104

Introduces the Product Change Control (PCC) module as a flexible information storage tool that allows the user to control and monitor product changes throughout the creation process.

PCR/PCO Life Cycle 106

Discusses the information PCRs and PCOs can contain and their most effective uses.

Setting Up PCC 108

How to set up Product Change Control.

Creating PCRs and PCOs 118

How to create PCOs using PCO Maintenance.

Routing PCRs and PCOs for Approval 130

How to route PCOs for approval using Route PCO for Approval.

Approving PCRs and PCOs 131

How to approve PCOs using PCR/PCO Approval.

Incorporating PCOs into Production 132

Once a PCO is approved, use the PCO Implementation menu to update production data.

Closing PCRs and PCOs 136

How to use PCR/PCO Close to close or reopen any PCO that has not been assigned an effective date in Incorporation Selection.

Importing and Exporting PCRs and PCOs 136

Use PCR/PCO Import/Export to export closed PCO data to an ASCII file for import into another database or application.

Setting Up PCC Security 136

How to set up PCC security.

Introduction to PCC

The Product Change Control (PCC) module is a flexible information storage tool that enables you to control and monitor product changes from inception through implementation. With PCC, you can modify item engineering data, product structures, routings, formulas, processes, and item specifications without affecting the records that control production activity. You can define an approval cycle for product changes. After approval, changes can be incorporated into the database tables that manage product definition.

PCC is built around two types of documents:

- Product change requests (PCRs) record requests for product changes. PCRs only affect your product definitions when incorporated into a product change order (PCO). Typically, they are not strictly controlled. More than one PCR can exist per item.
- Product change orders (PCOs) manage the introduction of changes into your product definitions. PCOs are usually strictly controlled through an approval process. Only one PCO can exist for an item at any one time.

PCRs and PCOs can be used to control changes to most item-related data in a manufacturing environment, including the following:

- Basic item and item-site inventory, planning, and cost data maintained in:
 - Item Data Maintenance (1.4.3)
 - Item Inventory Data Maintenance (1.4.5)
 - Item Planning Maintenance (1.4.7)
 - Item Cost Maintenance (1.4.9)
 - Item-Site Inventory Data Maint (1.4.16)
 - Item-Site Planning Maintenance (1.4.17)
 - Item-Site Cost Maintenance (1.4.18)
 - Additions, changes, and removals of product structure and formula records, including alternate BOMs maintained in Product Structure Maintenance (13.5) and Formula Maintenance (15.5).
- Note** PCC replaces the engineering change order (ECO) programs available from menu 13.13.
- Additions, changes, and removals of product routings and processes maintained in Routing Maintenance (14.13.1), Routing Maintenance (Rate Based) (14.13.2), Process Definition Maintenance (15.13), and Process/Formula Maintenance (15.18).
 - Additions, changes, and removals of item specification and test steps developed in Item Specification Maintenance (19.1.13).

A single PCO can affect numerous item numbers, formulas, product structures, routings, processes, or item specifications. New item numbers required by PCOs or PCRs can be created using a screen similar to Item Data Maintenance (1.4.3), accessed from PCR and PCO Maintenance. The revision number of an item added this way is blank until the PCO adding it is finally implemented.

Add new items needed by a PCR or PCO with an inactive status to ensure they do not appear prematurely on production reports, and are not visible to MRP. While new items are inactive, you can set up additional data, such as inventory, planning, and costing. When implemented, a PCO can change an inactive item's status to active.

Note You cannot use PCC to maintain alternate routings or co/by-product structures

You can deactivate only the first level of a product structure or selected operations for a routing from with the PCC module.

Copied Records

To use PCRs and PCOs, you first create new production and planning records, or copy existing records into PCRs/PCOs from production database tables. You can also create a new structure, routing, formula, or process record from production or from within PCC by copying an existing one to a new name, then optionally modifying it.

After you copy production records, you can modify them and specify the required product changes. These changes do not affect the data used for production and planning until the PCO is approved and incorporated. When this happens, modified records and any new records are copied from the PCO back into the production environment. Figure 4.1 illustrates the process of copying data into a PCO, making changes, and updating the production tables.

Fig. 4.1
PCO Change Process

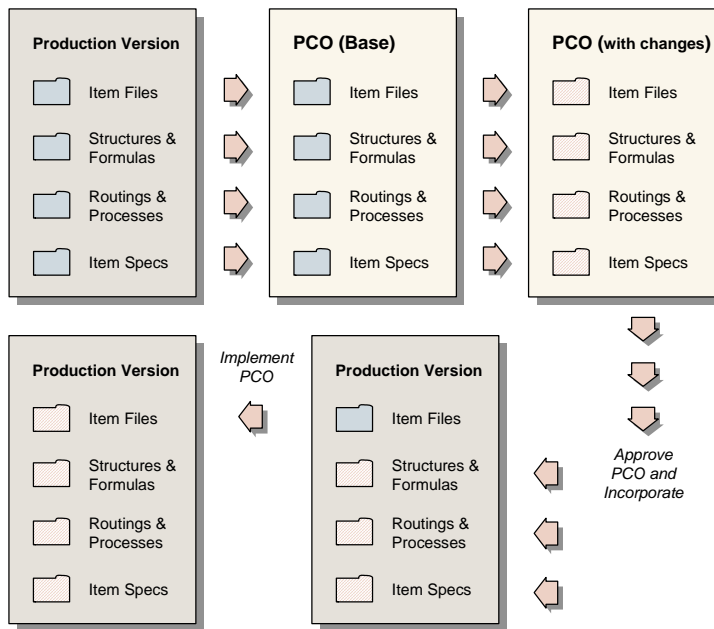

Product changes are copied into production and planning tables after an effective date is set for a PCO. The effective date becomes the start date for new records. This way, product changes can be used for planning before the actual effective date arrives and before the records are used for production.

Any changes made by a PCO to item records are copied into master item tables in a separate implementation step on the PCO effective date.

PCR/PCO Life Cycle

Figure 4.2 represents the PCR/PCO life cycle.

Fig. 4.2
PCR/PCO Life Cycle

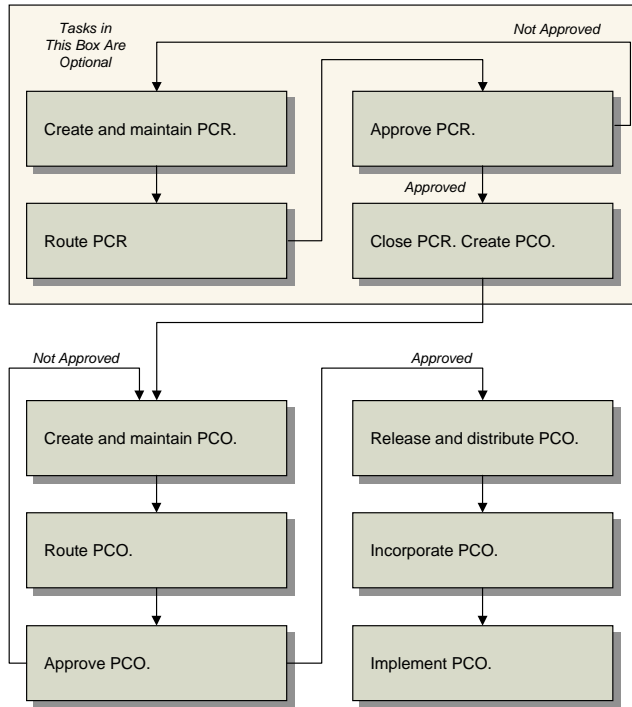

PCR Life Cycle

PCRs can contain the same information as PCOs, but cannot be taken past the approval stage to release. They are useful for companies that receive requests from various sources, such as customers or field representatives, and hold the requests for further processing. You can set up PCC to require a PCR approval process. Once approved, PCRs are typically closed or converted into PCOs. A PCR, approved or not, has no effect on the system until converted into a PCO.

Creating and Maintaining PCRs

Create PCRs in PCR Maintenance (1.9.2.1). You can use PCR Maintenance to:

- Capture and modify item, product structure, formula, routing, process, and item specification records. The Type/Design Group combination determines the PCR routing slip and distribution group.
- Create a new structure, routing, formula, or process by copying an existing one from production or from within PCC to a new name and then optionally modifying it.
- Deactivate the first level of a product structure or selected operations for a routing.

Routing PCRs for Approval

When a PCR is ready for review, comment, and approval, route it using Route PCR for Approval (1.9.2.4). Groups and users who must approve the PCR can be notified with e-mail or printed output that the PCR is ready for review. PCRs that have been routed for approval can be revoked, if necessary, for revision or correction.

Note PCO approval groups are not the same as standard security roles used throughout the system. They apply only to the PCC approval process.

Approving PCRs

Use PCR/PCO Approval (1.9.6.1) to monitor the queue of submitted PCRs, add comments, and approve or disapprove each PCR. Disapproved PCRs can be routed back to reviewers for reapproval. The order of approvals is determined by the routing slip attached to each PCR. Once a PCR has been approved electronically by all necessary personnel, it can be closed, or converted into a PCO using PCR Maintenance (1.9.2.1).

PCO Life Cycle

The life cycle of a PCO is more extensive than that of a PCR, since PCOs typically affect production data.

Creating PCOs

Create PCOs in PCO Maintenance (1.9.2.13). Also use PCO Maintenance to:

- Capture and modify item, product structure, formula, routing, process, and item specification records. You can also create PCOs by copying or combining existing PCOs or PCRs, or by converting PCRs.
- Create a new structure, routing, formula, or process by copying one from production or from within PCC, changing the name, then optionally modifying it.
- Deactivate the first level of a product structure or selected operations for a routing.

Routing for PCOs for Approval

When a PCO is ready for review, comment, and approval, route it using Route PCO for Approval (1.9.2.16). Groups and users who must approve the PCO can be notified by e-mail or printed output that the PCO is ready for review. PCOs that have been routed for approval can be revoked, if necessary, for revision or correction.

Approving PCOs

Use PCR/PCO Approval (1.9.6.1) to monitor the queue of submitted PCOs, add comments, and approve or reject each PCO. Disapproved PCOs can be routed back to reviewers for reapproval. The order of approvals is determined by the routing slip attached to each PCO. Once the PCO has been approved electronically by all necessary personnel, it is ready to be released.

Release and Distribution

You can release only approved PCOs to manufacturing. Use Release and Distribution (1.9.7.1) to monitor the queue of approved PCOs and choose PCOs to release. If necessary, you can revoke approval of a PCO before release and return it for revision or correction.

Once released and distributed, the PCO can no longer be rejected or modified. Any changes affecting the PCO must be released as separate PCOs. At distribution time, the system automatically generates either hard-copy release notices or e-mail for a defined group of users, either immediately or through batch print queues.

Once a PCO has been officially released, the manufacturing organization is responsible for implementing the changes. Engineering can specify a mandatory date for changes, or allow manufacturing to select a changeover date based on least cost, minimum disruption, or other relevant factors.

Incorporating PCOs

Use Incorporation Planning Report (1.9.7.3) to display inventory levels and monetary values of inventory affected by a PCO. This can help in planning effective dates for changes.

Note An enhanced version of Incorporation Planning Report is available at menu 1.9.7.27 for .NET UI users only.

Use Incorporation Selection (1.9.7.4) to monitor and assign effective dates. Then, incorporate it into production using Incorporation (1.9.7.5). You can modify an effective date by incorporating a PCO again with a different date.

Once a PCO is incorporated, MRP uses the effective dates of product changes to plan future orders. However, until the effective date is reached, PCO changes do not affect current operations.

Implementation

When a PCO's effective date has arrived and all changed items, product structures, formulas, routings, processes, and item specifications are in production, use Implementation (1.9.7.13) to move the new item revision numbers and other item data into the corresponding item master records.

Setting Up PCC

To set up PCC:

- 1 Prepare data for use with PCC.
- 2 Set up PCC Control.
- 3 Define user roles.
- 4 Define approval routings.
- 5 Define document change types.
- 6 Set up PCC security. See “Setting Up PCC Security” on page 136 for details.

Preparing Data for Use with PCC

To prepare data in other parts of the system for use in PCC, do the following:

- 1 Print existing ECOs, if any, using ECO by ECO Number Report (13.13.3). Implementing PCC disables ECO functions. You print ECOs in order to reenter them as PCOs.
- 2 Determine which manufacturing processes you want to control with PCC, and activate the appropriate sections. There are four possible activation programs:
 - Execute Enable PCC Structure Maintenance (13.13.22). Set Structures to Yes to control product structures. This automatically disables ECO functionality in menu 13.13.
 - Execute Enable PCC Routing Maintenance (14.22). Set Routings to Yes to control product routings.
 - Execute Enable PCC Formula Maintenance (15.22). Set Formulas and Processes to Yes to control formulas and processes.
 - Execute Enable PCC Item Spec Maintenance (19.1.22). Set Item Specifications to Yes to control item specification.

Important Once you enable PCC and thereby disable ECO functions, do not use the ECO functions. Enabling PCC makes changes to your system that cannot be reversed.

- 3 Set up e-mail definitions for your system in E-mail Definition Maintenance (36.4.20). PCC uses e-mail to contact users during the approval process and life cycle of change documents. See *User Guide: QAD System Administration* for information on E-Mail Definition Maintenance.
- 4 Create user IDs in User Maintenance (36.3.1). PCC users must be defined before they can be added to groups involved in PCC activities. Assign user passwords, or have users select their own. You can increase PCC security by requiring users to reenter passwords before accessing PCR/PCO Approval.

If you are using e-mail to notify users of PCC activities, make sure that each user has a valid e-mail address and definition.

Note For security audit purposes, you cannot delete a user ID in User Maintenance after it has been successfully used for login. Instead, unneeded IDs are deactivated. When a user who is involved in the PCC life cycle is deactivated, be sure to update PCC groups and routing slips so that e-mail notifications are not sent to users who no longer can access the system; for example, those who have left the company. See *User Guide: QAD Security and Controls* for information on users and security.

- 5 Set up printers and batch IDs (36.13.2, 36.14.1, 36.14.3). Users can be notified at various points in the PCC life cycle either by printed reports or e-mail. Batch IDs are useful for running large print jobs during off-hours. Also, PCOs can be distributed (1.9.7.1), incorporated (1.9.7.5), and implemented (1.9.7.13) using batch IDs that execute nightly.
- 6 Initialize PCOs in PCC Control (1.9.24). The first time you enter PCC Control, you are prompted to initialize PCOs to current revision level. Answer Yes to have the system create PCO *000000*, which records current revision numbers for all items in the system. The initial revision numbers serve as a starting point for Item Revision History Browse (1.9.9.6).

- 7 It is important for purchase orders and for the operation of the Product Change Control module that the engineering revision level for an item is the same in Item Master Maintenance and Item-Site Planning Maintenance. Use the Item Revision No Variation Report (1.9.9.9) to highlight any revision variations for review and correction.

Setting Up PCC Control

Use PCC Control (1.9.24) to specify how PCRs and PCOs are processed.

Fig. 4.3
PCC Control (1.9.24)

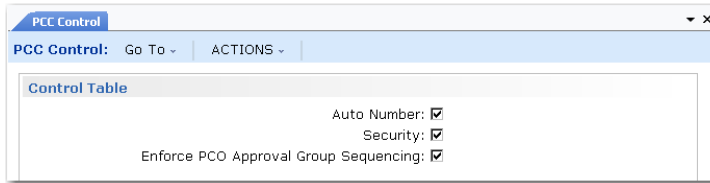

Auto Number. Select Yes to generate document numbers automatically when a new PCR or PCO is created. Enter No to enter numbers manually when creating PCRs or PCOs.

Security. Select Yes to verify user identity when PCR/PCO Approval (1.9.6.1) is accessed. If Yes, users are prompted to enter a password before the screen displays. The password they enter must match the one associated with their user record in User Maintenance (36.3.1).

Enforce PCO Approval Group Sequencing. Specify whether the system lets you complete approval of a PCR or PCO even if it has not yet been approved by a member of a group with a lower sequence number. Approval sequences are assigned to groups in Routing Slip Maintenance.

No (the default): The system displays a warning message if approvals are attempted out of sequence. You can ignore the warning and complete the approval.

Yes: The system displays an error message if you attempt to approve a PCR or PCO out of sequence. You cannot complete the current approval.

This field also controls whether a group member can update the Approved field on a PCR or PCO if it has already been approved by a member of a group with a higher approval sequence. When the field is Yes, the system displays an error.

Fig. 4.4
PCC Control (1.9.24), Auto Number Frame

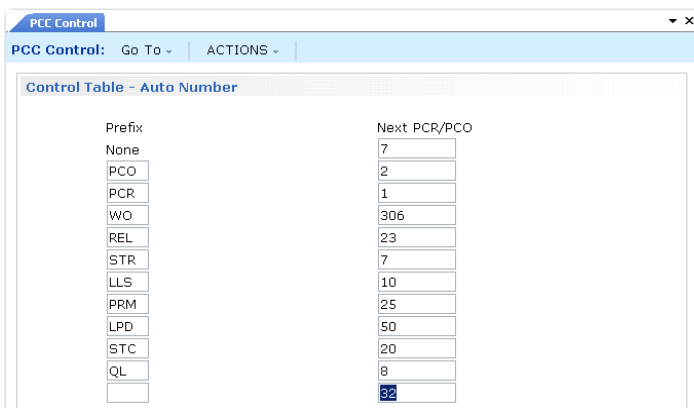

Prefix. If Auto Number is Yes, the system assigns a prefix based on the PCR/PCO Type specified and associates the prefix with the Next PCR/PCO field to create a unique number. Multiple prefixes can be specified. Use the null prefix for types that do not reference a specific prefix.

Note Types are defined in PCR/PCO Type Maintenance (1.9.1.9).

Next PCR/PCO. The next number available for an associated prefix. When the prefix is used to label a new document, the portion of the number after the prefix is determined by this field.

Defining Groups, Routing Slips, and Change Types

Three kinds of data are defined in the PCC setup menu: groups, routing slips, and document change types. These three data structures work together to form a model of your company's product change and approval process.

Figure 4.5 shows how PCC groups, routing slips, and change types are used.

Fig. 4.5
PCC Setup Functions

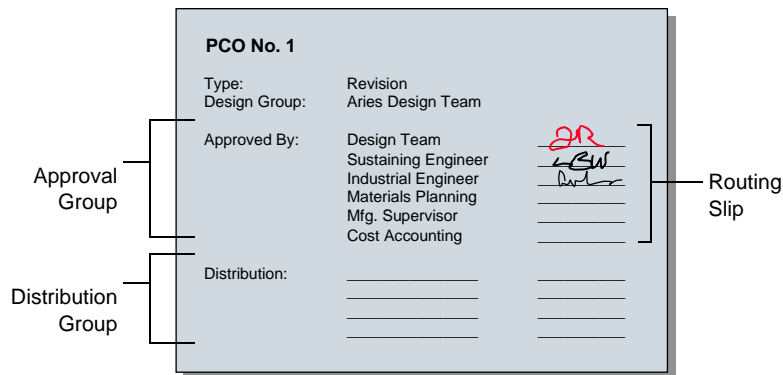

Creating Groups

In PCC, groups represent users with different functional responsibilities. Groups are used in three ways:

- **Design.** Groups designate which users have authority to create and maintain PCRs and PCOs. For example, members of an engineering team might make up one design group. PCRs and PCOs are organized by type and design group, since the design group is the driving force behind change development.
- **Distribution.** Groups designate which users are notified automatically when a PCO has been released.
- **Approval.** Groups designate which users have authority to approve PCRs and PCOs.

Use Group Maintenance (1.9.1.1) to define PCC groups.

Fig. 4.6
Group Maintenance (1.9.1.1)

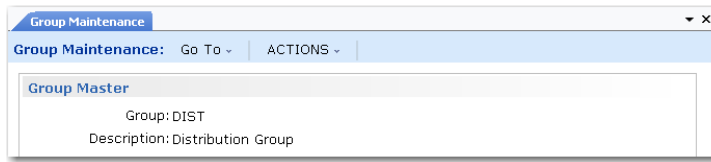

In the first frame, enter a unique group name and a brief description. Use the second frame to add users to the group, and specify group attributes.

Important Users added to groups must be previously defined with User Maintenance (36.3.1).

Fig. 4.7
Group Maintenance (1.9.1.1), Add Users

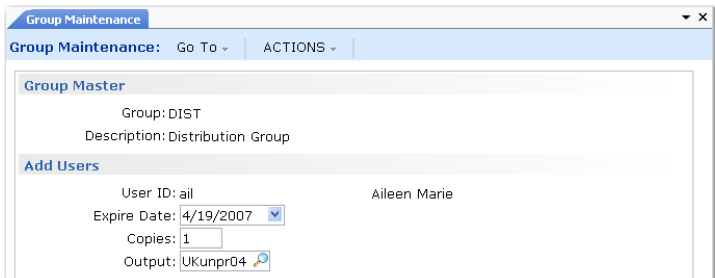

User ID. Enter the user ID to add.

Expire Date. Optionally, enter a date when the user is no longer considered an active member of the group.

Copies. Enter the number of printed copies to be printed on the printer specified in Output. Enter zero to have the user notified by e-mail. Specify the e-mail address in User Maintenance (36.3.1).

Output. Typically, the printer on which PCC-related notices are printed.

Changing Group Memberships

Use Maintain Users in Group (1.9.1.3) to change group memberships. You can add, replace, or remove a user from one or more groups. Changes can be made to more than one group at a time, as when a user in several design groups transfers to another department or leaves the company.

Fig. 4.8
Maintain Users in Groups (1.9.1.3)

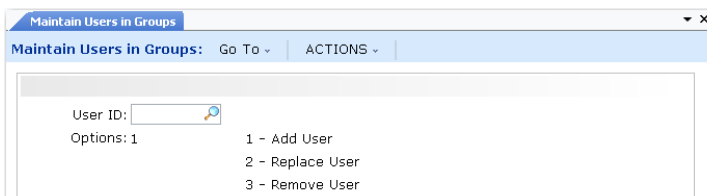

After you select the option you want, one of the following frames displays.

Adding Users to Groups

Choose option 1 to add users to groups. The Add User frame displays.

Fig. 4.9
Maintain Users in Groups (1.9.1.3), Add User

The screenshot shows a window titled 'Group Maintenance'. At the top, there is a 'Group Maintenance:' label with 'Go To' and 'ACTIONS' dropdown menus. Below this is a 'Group Master' section with 'Group: DIST' and 'Description: Distribution Group'. The main section is 'Add Users', which contains the following fields: 'User ID: ail' (with 'Aileen Marie' to its right), 'Expire Date: 4/19/2007' (with a dropdown arrow), 'Copies: 1' (with a text input field), and 'Output: Ukunpr04' (with a file selection icon).

Expire Date, Copies, Output. To modify these user attributes, enter new values.

List Groups for User ID. Optionally specify the ID of a user to display only groups to which this user belongs or leave blank to display all defined PCC groups to which the user being added does not currently belong. Specifying groups can be useful when defining one user's membership so that it resembles that of another user.

Available Groups. Select a group to add the user to, and choose Add. Select multiple groups by holding down Shift during selection.

Selected Groups. To deselect a group, highlight it and choose Remove.

Click Done when you are finished adding this user to groups.

Replacing Users in Groups

Choose option 2 to replace users in groups. The Replace User frame displays.

Fig. 4.10
Maintain Users in Groups, Replace User

The screenshot shows a window titled 'Maintain Users in Groups'. At the top, there is a 'Maintain Users in Groups:' label with 'Go To' and 'ACTIONS' dropdown menus. Below this is a section with 'User ID: ail' (Aileen Marie) and 'Options: 2'. A list of options is shown: '1 - Add User', '2 - Replace User', and '3 - Remove User'. The main section is 'Replace User', which contains 'Replace with User ID: crl' (Caroll KE) and 'Expire Date:'. Below this is an 'Available' section with a 'Select' label and a list of groups: 'DES' and 'DIST'.

User ID. Enter the user ID of the old user.

Replace with User ID. Enter the user ID of the new user.

Note You can modify a user's attributes by specifying the same user in both User ID fields.

Expire Date, Copies, Output. Modify these user attributes as needed.

Group. The list includes all groups to which the old user belongs. Select a group and choose Add to move it to the Selected Groups list. Select multiple groups by holding down Shift during selection. To deselect a group, select it a second time.

Removing Users from Groups

Select option 3 to remove users from groups. The Remove User frame displays.

Fig. 4.11
Maintain Users in Groups, Remove User

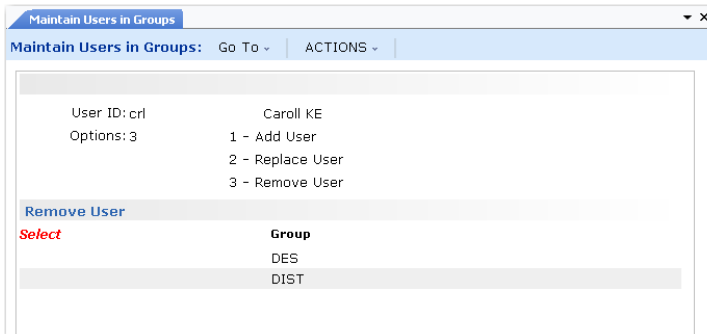

User ID. Enter the user ID of the user being removed.

Group. The list box includes all groups to which the user being removed belongs.

Defining Approval Routings

Approval routings specify who needs to approve a change, and in what order approvals are required. Approval routings are represented by routing slips, which can be created manually or copied from routing templates and modified. Routing slips also indicate who is to be notified when documents are approved. Every PCR and PCO requiring approval must have a routing slip.

Create original routing slips in Routing Slip Maintenance (1.9.1.5), or copy existing routing slip templates and make required modifications. If you modify a routing template, the changes only affect new PCRs and PCOs.

Fig. 4.12
Routing Slip Maintenance (1.9.1.5)

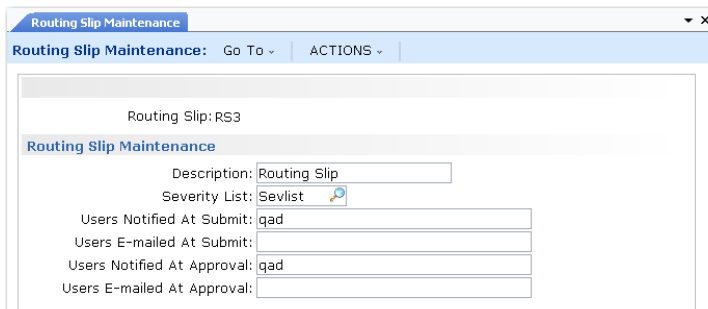

Routing Slip. Enter a unique code identifying the routing.

Description. Enter a description of the routing.

Severity List. Enter a code indicating the severity list to be used for this routing. Severity lists are predefined lists of defects, ranked according to how severe each defect is considered. For example, a severity list of hardware defects might appear as follows, with higher numbers being more severe.

- 5 Cosmetic/typographical correction
- 10 Minor drawing/layout change
- 20 Major drawing/layout change
- 30 Wrong dimensions
- 40 Missing part

Create severity lists in Reason Codes Maintenance (36.2.17) by defining typical defects and assigning them severity rankings. Group reason codes by a type such as PCC.

When a member of a group with authority to reroute an approval rejects a change in PCR/PCO Approval, a prompt for severity level displays.

Users Notified at Submit or Approval. A routing slip can include a list of users to be notified at the beginning and end of the approval cycle. Users notified must be defined as users in the system, but do not have to be members of PCC groups. The system determines the appropriate e-mail address from data specified in User Maintenance. Separate multiple user IDs with commas.

Users E-mailed at Submit or Approval. Enter e-mail addresses of persons outside your organization, such as key suppliers, who are to be notified at the beginning and end of an approval cycle. Enter full e-mail addresses, maximum 240 characters. Leave blank to notify only internal personnel. Check e-mail addresses carefully to avoid errors. This field cannot be validated.

Enter approval routing details in the Detail Maintenance frame.

Fig. 4.13
Routing Slip Maintenance, Detail Maintenance

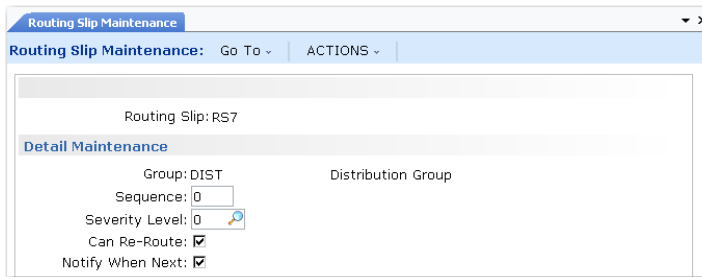

Sequence. Enter a number from 0 to 999 specifying the group’s sign-off position relative to other groups in the routing. If zero, groups can review the document in any order.

Table 4.1 illustrates three types of approval sequences.

Table 4.1
Sample Approval Sequences

Hierarchical	Semi-Hierarchical	Non-Hierarchical
Engineering 0	Engineering 0	Engineering 0
Production 10	Production 0	Production 0

Hierarchical		Semi-Hierarchical		Non-Hierarchical	
QA	20	QA	0	QA	0
Finance	30	Finance	10	Finance	0

When a non-hierarchical order is used, groups can review the document in any order. Skip some sequence numbers to facilitate addition of groups in the future.

When a hierarchical or semi-hierarchical order is used, you can use the Notify When Next field in combination with the Next Only field in PCR/PCO Approval to display only those PCOs approved by all subordinate groups.

Set Enforce PCO Approval Group Sequencing to Yes in PCC Control to ensure that users follow the correct sequence during approval.

See page 110.

Severity Level. Enter a number indicating what severity of defect results in PCRs and PCOs being rerouted to this group. Lower numbers mean that minor defects are rerouted to this group. If you are not using severity levels, enter zero.

The severity level acts as a filter to prevent needless review and streamline the PCO approval process.

The system reroutes a PCO to a group whenever the group in question has approved the change document *and*:

- The change document is rejected by another group on the routing slip that has reroute authority (Can Re-Route is Yes), *and*
- The rejecting group sets the reroute level to a number greater than or equal to the severity level in this field.

Can Re-Route. Enter Yes to indicate that this group has the authority to reroute a PCO when they reject it. To effectively disable rerouting, enter No for all routing slips.

Important Disabling rerouting means that *every* group on a routing must reapprove a corrected document.

Notify When Next. Check this box to have the system notify each group when it is next, based on sequence number, in an approval routing. Users to notify should have valid e-mail addresses.

Routing Slip Copy

Create new routing slips based on existing routing slip templates in Routing Slip Copy (1.9.1.7).

Fig. 4.14
Routing Slip Copy (1.9.1.7)

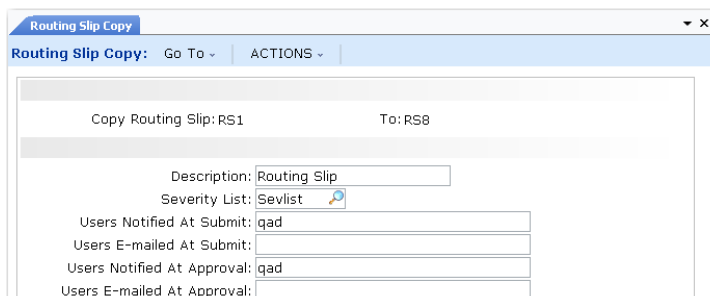

The list of users to notify at submission and approval defaults from the source routing and can be modified. When you click Next, you are prompted to copy the routing detail. Respond Yes to have the system copy approval routing details for each group from the source routing to the new routing. If you respond No, groups can still be added later using Routing Maintenance.

Defining Document Change Types

Use PCR/PCO Type Maintenance (1.9.1.9) to set up codes for PCR and PCO types. The type code determines whether the change document is a PCR or a PCO, and determines the routing slip, distribution group, prefix, and number.

Defining document change types requires careful planning. Some criteria to consider are:

- Purposes of the PCO, such as to enhance safety, upgrade functionality, reduce cost
- Product lines affected by the PCO
- Design areas affected by the PCO, such as electrical, mechanical, or pneumatic
- Approvals required for the PCO

Fig. 4.15
PCR/PCO Type Maintenance (1.9.1.9)

The screenshot shows a software window titled "PCR/PCO Type Maintenance". The window contains the following fields and values:

- Type: PCO
- Design Group: DES
- Description: ProductChange Not
- Document Type: PCO
- Prefix: PCO
- Routing Slip: RS2
- Distribution: DIST

Type. Enter a code identifying this type of change document.

Design Group. Enter a group defined in Group Maintenance that has design responsibility for this type of change document.

Description. Enter up to 24 characters describing this document type.

Document Type. Indicate whether this type is used for PCRs or PCOs.

Prefix. An optional, three-character prefix for document numbers, used to distinguish different kinds of changes. Prefixes and number sequences are defined in PCC Control and used when Auto Number is Yes to determine the number for a new PCO or PCR. If you enter a prefix that is not set up in the control program, a warning displays.

Routing Slip. Enter the routing slip associated with documents of this type. The routing slip determines which groups must approve the document and in what order.

Distribution. Enter the group to be notified when documents of this type are released and distributed with Release and Distribution (1.9.7.1).

Creating PCRs and PCOs

This section focuses on creating PCOs in PCO Maintenance (1.9.2.13). PCR Maintenance (1.9.2.1) is almost identical to PCO Maintenance and is not described separately. It contains two additional functions that enable you to create a PCO based on an approved PCR.

PCO Maintenance (1.9.2.13) is a large and complex program used to create PCOs and add and modify all product change data, including any of the following types:

- Basic header data
- Text detail
- Item detail
- Item-site detail
- Product structure/formula detail
- Routing/process detail
- Item specification detail
- Trailer data

Submenus in PCO Maintenance enable you to navigate from one PCO section to another.

The header frame of PCO Maintenance contains basic information about the PCO.

Fig. 4.16
PCO Maintenance (1.9.2.13), Header Frame

PCO Maintenance

PCO Maintenance: Go To - ACTIONS -

Number: PCO00001 ID: Domain: PCO
 Type: PCO Design Group: DES Created By: mfg 04/16/2007

Title:

Reason:

Class: User Code 1:
 Originator: User Code 2:

A PCO is uniquely identified by a combination of Number, ID, and Domain fields. If you enter a combination that does not already exist, a new PCO is created. An error displays if you try to perform maintenance on a distributed PCO, and a warning displays if you open a PCO already routed for approval. If you continue despite the warning, any approvals are essentially revoked, and the document must be rerouted for approval.

See “Routing PCRs and PCOs for Approval” on page 130 for details.

If you do not enter a number and Auto Number is Yes in PCC Control, the system automatically generates a number based on your entries in PCO Type and Design Group. PCO Type determines the prefix and number, which default from PCC Control.

ID. Enables you to create multiple PCOs with the same PCO number for grouping purposes. Typically used to divide large PCOs into smaller ones for ease of implementation. When you open a PCO with a shared number and different ID, you are warned that related PCOs exist.

Domain. Use this field to enter an optional domain name; the field is not validated and does not automatically create any physical link to, or interaction with, another system database. This field is intended for multi-domain installations where product development and manufacturing are performed at separate locations. In this case, the same change can have different implementation details at different factories, accommodating variations in specific item numbers, work centers, and so on. Domain then becomes an important selection criterion in PCR/PCO Import/Export (1.9.13).

Type and Design Group. This combination must be defined in PCR/PCO Type Maintenance (1.9.1.9). The values specified determine the approval cycle, distribution group, and document change type. If a number is not entered and autonumbering is used, this combination also determines the PCO number.

Note Review routing slip and distribution group data for a PCO in the trailer, using the Trailer Maintenance menu. The same information displays in PCR/PCO Close (1.9.14).

Once you have created or accessed a PCO, you can enter and change Title, Reason, Class, Originator, and User Codes. These are user-defined and typically used to provide PCO reference summaries. They do not affect PCO processing, but display in PCO Browse (1.9.2.14), Print PCR/PCO (1.9.9.1), and Release and Distribution (1.9.7.1).

After entering basic PCO data, a section menu enables you to navigate elsewhere in PCO Maintenance. Click the arrow next to a menu selection to activate it.

Fig. 4.17
PCO Maintenance, Section Menu

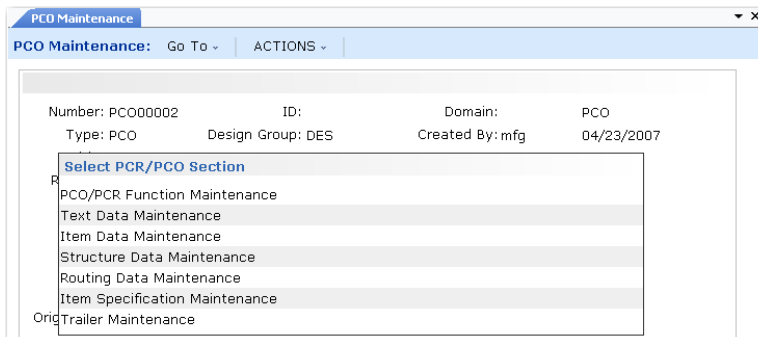

Using PCR/PCO Function Maintenance

This program provides several utilities to support the copying and merging of PCOs and PCRs. A submenu displays several choices.

Fig. 4.18
PCO/PCR Function Maintenance Menu

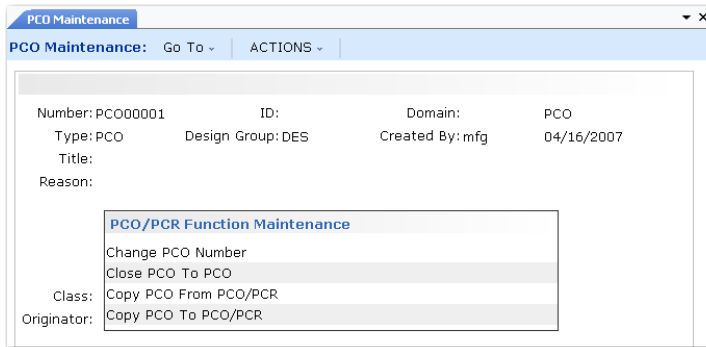

- **Change PCO Number.** Used to change the Number, ID, and/or Domain fields of the PCO you are currently editing. Enter new values for these fields to have the system execute the required change immediately. Once completed, the PCO can no longer be accessed using the old number/ID/domain values.
- **Close PCO to PCO.** Used to merge detail from the PCO currently being edited into another existing PCO, then close the current PCO. If the same item, product structure, or formula records exist in the target PCO, the corresponding records are not copied.
- **Copy PCO from PCO/PCR.** Used to copy all or part of the detail from another PCO/PCR into your current document. If the same records already exist in the target PCO, they are not copied.
- **Copy PCO to PCO/PCR.** Used to copy all or part of the detail from your PCO to another one. If the same records are already included in the target PCR/PCO, they are not copied.

Two additional functions are available from PCR Maintenance, illustrated in Figure 4.19.

Fig. 4.19
PCO/PCR Function Maintenance Menu

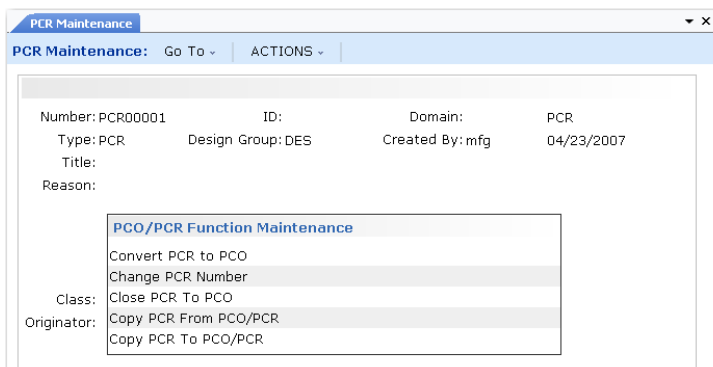

- **Close PCR to PCO.** Used to merge the detail from the PCR you are currently editing into an existing PCO and then close the current PCR. If the same records exist in the target PCO, they are not copied. This is the only way a PCR can affect the production system, since PCRs cannot be released and distributed.
- **Convert PCR to PCO.** Converts the PCR you are currently modifying to a PCO. You are prompted for a new PCO type and design group, since the current type is designed for PCRs. Once you enter a valid PCO type and design group combination, the PCR becomes a PCO with the same number.

Maintaining Text Records

Select Text Data Maintenance to enter multiple pages of text and associate it with a PCO. Another submenu offers two options.

- **Add, Modify, Delete PCO Text Data.** Enables entry of transaction comments for a PCO.
- **Copy Text from Master Comments into PCO.** Enables master comments to be attached to the requested PCO. You can enter the master reference and type in a pop-up frame or leave the fields blank to display a selection list of existing master comments. Select one or more of them for copying into the PCO.

Note Define master comments with Master Comment Maintenance (1.12).

You can use master comments to create reusable text templates that can be pulled into change documents and then edited. They might include legal disclaimers, checklists, standard operating procedures, company policies, or internal surveys.

Maintaining Item Records

Select Item Data Maintenance to enter changes in item master data. You can make changes in the following item and item-site data:

- Inventory
- Planning
- Cost

Multiple selections are provided on the menu.

Fig. 4.20
PCO Maintenance (1.9.2.13), Item Data Frame

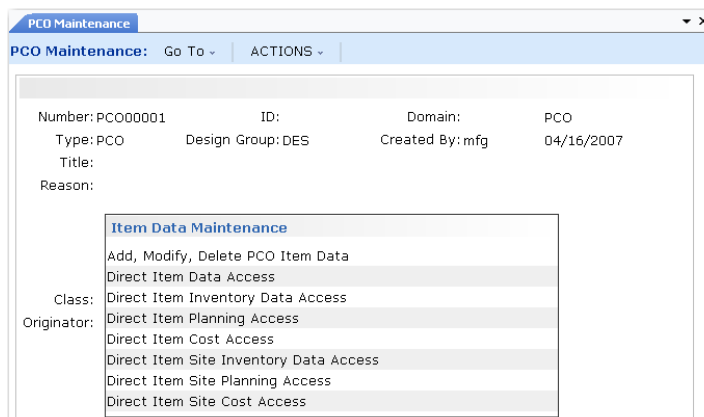

Add, Modify, Delete PCO Item Data enables you to change item master data fields for an existing item. Standard validation prevents the same item master from being changed by more than one undistributed PCO. Only data specified with Item Data Maintenance (1.4.3) can be modified.

Note You cannot add new item numbers with this function.

Each of the functions that begin with Direct let you run the equivalent function on the item menu. These functions directly affect production records; updates are made in item master and item-site detail tables, not in the PCO tables.

For example, Direct Item Data Access is the equivalent of invoking Item Data Maintenance (1.4.3) and enables you to add a new item number, enter item master data, and enter item-site data directly into the production database.

Direct Item Data Functions

Table 4.2 lists the program that you call when you invoke the direct item access functions. If security options are set for the programs, PCC applies the security options, also.

Table 4.2
Direct Item and Item-Site Programs Accessed

PCO/PCR Item Data Maintenance Menu Option	Accessed Program	Menu Number
Direct Item Data Access	Item Data Maintenance	1.4.3
Direct Item Inventory Data Access	Item Inventory Data Maintenance	1.4.5
Direct Item Planning Access	Item Planning Maintenance	1.4.7
Direct Item Cost Access	Item Cost Maintenance	1.4.9
Direct Item Site Inventory Data Access	Item-Site Inventory Data Maint	1.4.16
Direct Item Site Planning Access	Item-Site Planning Maintenance	1.4.17
Direct Item Site Cost Access	Item-Site Cost Maintenance	1.4.18

With these functions, item numbers can be created in production environment rather than in the engineering work space, since important functions may require that they exist before the PCO is released. Impact analysis and the creation of a quotation request are examples of functions that depend on the existence of item numbers.

Add, Modify, Delete PCO Item Data

Figure 4.21 illustrates the screen that displays when you select Add, Modify, Delete PCO Item Data.

Fig. 4.21
Add, Modify, Delete PCO Item Data

The screenshot shows a software window titled "PCO Maintenance" with a sub-header "ecmt06.p Add, Modify, Delete PCO Item Data". The form contains the following fields and values:

- Number: PCO00001, ID: , Domain: PCO
- Title:
- Item Number: 1-BB, Description: Red Bean Bag
- Unit of Measure: EA
- End Product:
- Comments:
- Prod Line: 1000, Item Type: FG, Drawing:
- Added: 06/27/2001, Status: AC, Drawing Loc: , Size:
- Design Group: DES, Group: , Disposition:
- Price Break Category:
- Current Rev: , Released Rev: , New Revision:

Key fields in the program are as follows.

End Product. Indicate if this item is the end product affected by the PCO. Often, PCO details apply to low-level components that affect higher-level items. This field is for reference only.

Comments. Enter Yes to attach comments regarding the change.

New Revision. Enter a revision level indicator for the item. The item's revision level is updated when the PCO is implemented. Revision levels are alphanumeric codes such as 1b, aa, B3, c.34, 6q3. To use strictly numeric values, fill the number with zeros (0001, 0002, and so on). Revision levels can be skipped, but cannot be specified in descending sequence.

The New Revision value must be greater than the Released Rev value, which shows the revision level of the most recently released PCO affecting the item.

Status. New items created for a PCO can be given an item status that prevents their use in live transactions. The status field on the PCO can be set so that at implementation the restricted status is replaced with an active one.

Maintaining Product Structure Records

To use these functions, Product Structures must be Yes in Enable PCC Structure Maintenance (13.13.22). Otherwise, Structure Data Maintenance is not available from the Select PCR/PCO Section submenu.

Select Structure Data Maintenance to copy or deactivate product structures, add items to product structures, or replace product structure components. You can also create a new product structure by copying an existing one, renaming it, then optionally modifying it. Formula-controlled items must be updated in Formula Data Maintenance.

Another submenu offers six selections:

- **Copy Product Structure into PCO.** Copies or creates new product structures into the PCO to serve as a basis for further modification. You can optionally specify the product structure level to copy. You can create new product structures by copying existing ones from production or

from within PCC, renaming them, then optionally modifying them. If you copy a product structure and specify 0 (zero) for levels, the system copies all levels. Copied product structures contain the same field values as production records.

Note To attach comments to changes made with these functions, set Comments to Yes.

To copy the parent item from production, accept the default parent item in Destination Structure. To copy an existing parent item from production or PCC into a new structure, enter a new structure name in Destination Structure. See Figure 4.22.

Newly created structures do not exist outside of the PCC module until the PCO is incorporated/implemented. The release of the PCO triggers other activities, such as routing and product structure cost roll-ups.

Fig. 4.22
Copy Existing Product Structure to a New One

Level	Component Item	Description	Reference
1	100A-01	Mfg Comp	

If creating a new structure by copying an existing one, levels are preselected and marked with asterisks (*). If copying, records are not preselected.

- **Copy Where Used into PCO.** Works the same as Copy Product Structure into PCO, except it displays an indented where-used bill of material screen, and lets you select product structure records to copy into the PCO. This is useful if you are making the same change to several product structures.
- **PCR/PCO Detail Maintenance – Product Structures.** Used for adding items to product structures, deactivating product structure records, and editing product structure changes already added to the PCO. Records are not actually deleted. Deactivating a record sets an ending effective date when the PCO is incorporated.
- **Replace Product Structure Component.** Used in conjunction with other PCO functions to replace one component item with another across multiple bills of material.

Enter an existing component item number followed by a new one. The system accesses product structure records already included in the PCO, searching for occurrences of the requested component. It marks these product structures Deactivated (end effective date set) and adds new product structures for the same parent items, substituting the new component for the old one.

Fig. 4.23
Replace Product Structure Component

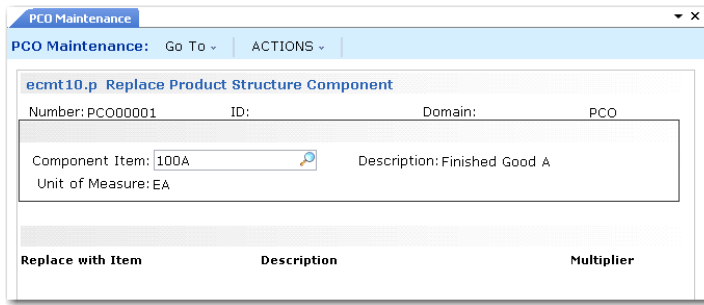

- **Copy Product Structure Within PCO.** This option is the same as Copy Product Structure into PCO, except that it starts from a product structure within the current PCO and lets you create similar ones.
- **Deactivate Product Structure.** Deactivates the product structure you specify in the Parent Item field. You can deactivate the parent item for level 1 only. The system displays a second frame with preselected structure content. Deselect records you do not want to deactivate.

Multiplier. Modifies the Qty Per value for the new component. The quantity per of the old component is multiplied by this number to determine the quantity per for the new component. As an example, an old component has a quantity per of 2. The multiplier is set to 0.5. The quantity per for the new component is 1.

Other detailed product structure data, such as Scrap % and Op, are copied from the existing record, although you can use other PCO Maintenance functions to change them.

To replace one component item with another across all bills of material, create a PCO and use Copy Where-Used into PCO to include every product structure record that used the old component. Then, use Replace Product Structure Component to deactivate the existing product structure records and add new ones that specify the new component. In this way, you can set up mass component maintenance on a PCO in two relatively simple steps.

Fig. 4.24
Deactivate Product Structure

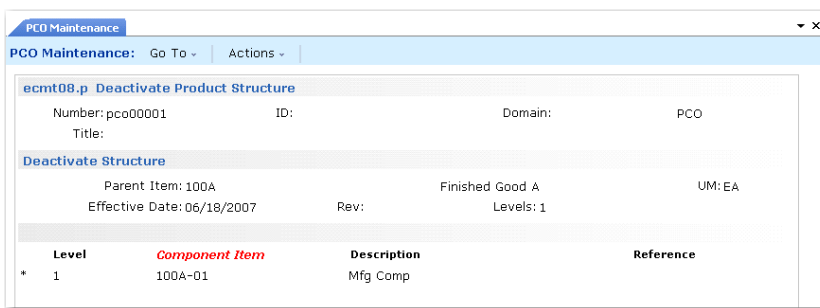

Maintaining Routing Records

Important To use these functions, Routings must be Yes in Enable PCC Routing Maintenance (14.22).

Select Routing Data Maintenance to copy, create a new, or deactivate routings and operations or to make additions, changes, and removals to both standard and rate-based routings. You can create a new routing by copying an existing one from production or from within PCC to a new name and then optionally modifying it. To modify processes, use Process Data Maintenance.

The Routing Data Maintenance submenu has the following selections:

- **Copy Routing to PCR/PCO.** Copies routing records into the PCO. Displays the operation for a routing and enables you to select any number of steps for inclusion in the PCO. Once copied, operations can be modified with Detail Maintenance.

To copy a routing from production, specify the source in the Routing/Procedure field, then accept the default routing in Destination Routing Code. To create a new routing from an existing one, copy the routing from production or PCC into a new routing, enter a new name in Destination Routing Code. See Figure 4.25.

The destination routing does not have to exist or be a valid item number. If it does exist in the production system and has operations, a warning displays. If you continue, existing operations are not overwritten. Any source operation numbers that do not exist in the destination are added, merging the two sets of operations.

Fig. 4.25
Copy Routing into PCO

The screenshot shows a window titled "PCO Maintenance" with a sub-header "PCO Maintenance: Go To ACTIONS". The main content area is titled "ecmt11.p Copy Routing to PCR/PCO". It contains the following fields and values:

- Number: PCO00002
- ID: (empty)
- Domain: PCO
- Title: (empty)
- Routing Copy: (checked)
- Routing/Procedure: 1001
- Effective Date: 04/23/2007
- Destination Routing Code: 1002
- Operation: (empty)
- To: (empty)

- **PCR/PRO Detail Maintenance – Routing.** Used to add operations to a routing, deactivate operation steps, and edit routing changes already added to a PCO. Records are not actually deleted. Deactivating a record sets an ending effective date when the PCO is incorporated.

Fig. 4.26
PCR/PRO Detail Maintenance – Routing

- **PCR/PRO Detail Maintenance – Routing (Rate Based).** Works just like Add/Edit/Deactivate Routing, except for differences in maintained data fields. The differences are the same as those between standard Routing Maintenance (14.13.1) and Routing Maintenance (Rate Based) (14.13.2).
- **Copy Routing Within PCO.** This option is the same as Copy Routing to PCR/PCO, except that it starts from a routing within the current PCO and lets you select operations to copy into another routing within this PCO. This is useful if you are making the same change to several routings.
- **Deactivate Routing.** Deactivates routings and operations. The system displays a second frame with preselected operations. Deselect operations you do not want to deactivate.

Maintaining Formula Records

Important To use these functions, Formulas must be Yes in Enable PCC Formula Maintenance (15.22).

Select Formula Data Maintenance to do the following:

- Copy or create new formulas into a PCO
- Copy where-used data into a PCO
- Maintain PCR/PCO formula details
- Replace formula components
- Copy or create new formulas by copying them into new ones within a PCO
- Deactivate a formula

These functions work just like the Product Structure Maintenance functions, except for differences in maintained data fields. The differences are the same as those between Product Structure Maintenance (13.5) and Formula Maintenance (15.5).

See “Maintaining Product Structure Records” on page 123.

Maintaining Process Records

Important To use these functions, Processes must be Yes in Enable PCC Formula Maintenance (15.22).

Use Process Data Maintenance to add, edit, copy, create a new, or deactivate processes. You can create a new process by copying an existing one from production or from within PCC to a new name and then optionally modifying it. These functions work just like the Routing Data Maintenance functions, except for differences in maintained data fields. The differences are the same as those between Routing Maintenance (14.13.1) and Process Definition Maintenance (15.13).

See “Maintaining Routing Records” on page 126.

Maintaining Item Specifications

To use these functions, Item Specifications must be Yes in Enable PCC Item Spec Maintenance (19.1.22).

Use Item Specification Maintenance to manage changes to quality tests associated with an item. You can copy item specifications defined in the Quality Management module and modify them in the PCO.

A submenu provides two selections:

- **Copy Item Specification From Quality Module.** Copies item specification records into the PCO. Displays the current sequence of steps for a given parent item and routing.

Fig. 4.27
Copy Item Specification From Quality Module

Quality Module - Item Specification Detail Records			
Number	Op	Characteristic	Specification
1	0	Purity	Clear
1	10	Purity	Clear
2	10	Size	.5
3	10	Finish	Shine

Measure
cm
Glossy

- **PCR/PCO Detail Maintenance – Item Specification.** Used to add, modify, and deactivate test steps for an item specification that has already been added to a PCO. Records are not actually deleted. Deactivating a record sets an ending effective date when the PCO is incorporated.

Maintaining Trailers

Use Trailer Maintenance to maintain important PCO data fields, and to close or reopen a PCO. This program displays release process information such as routing slip, distribution group, date submitted, and date approved. It is the only option that appears in the PCO Maintenance section menu for closed (but undistributed) PCOs.

Note PCR/PCO Close (1.9.14) displays almost the same information.

Fig. 4.28
PCO Trailer Maintenance

The screenshot shows a software window titled "PCO Maintenance". Inside, there's a sub-header "ecmctrl.p Trailer Maintenance". Below this, there are several input fields and labels: "Number: PCO00001", "ID:", "Domain: PCO", and "Title:". A section of fields includes "Expected Cost: 10.00", "Mandatory:" with a dropdown arrow, "Routing Slip: RS2", "Submitted:", "Distribution: DIST", "Approved:", "Disposition:", "Released:", "Effective:", "Closed:

Expected Cost. Optional. The expected cost of the PCO.

Disposition. Optional. A user-defined code to describe the arrangement, grouping, or urgency of the PCO. Validated against codes set up in Generalized Codes Maintenance (36.2.13) for field `ecm_ecr_dspn`.

Closed. If Yes, the PCO is closed. If No, the PCO is opened. A PCO cannot be reopened once it is distributed.

PCO Ref. Information-only. A cross-reference comment for a closed PCO.

Mandatory. Optional. The latest date on which the PCO must be implemented. A warning message is generated in Incorporation Selection (1.9.7.4) if an effective date is assigned to the PCO that is later than this date. The mandatory date is an engineering instruction to manufacturing, since the manufacturing group is responsible for PCO incorporation.

Reviewing PCO Data

Use PCR/PCO Detail Inquiry (1.9.2.8) to display PCR or PCO details.

Use Print PCR/PCO (1.9.9.1) to select and print a range of PCO/PCR details. Selection criteria include number, type, and created by. Set a comment page range to include comment pages attached to the PCO.

The Approvals field determines whether or not approvals are printed. To print PCOs in various life-cycle stages, use the status fields: Pre-submission, Submitted, Approved, Released, Incorporated, Implemented, Closed.

Use PCO Status Browse (1.9.11) to review the current status of PCRs and PCOs. The following statuses reflect the position of the PCR or PCO in the change life cycle:

- Submitted
- Approved
- Distributed (PCO only)
- Implemented (PCO only)
- Rejected
- Released (PCO only)
- Incorporated (PCO only)
- Closed

Use Approval Browse (1.9.6.2) to review sign-offs for a given PCO, including pending and completed approvals, individual approvers, and date of the approvals.

Routing PCRs and PCOs for Approval

Route PCOs for approval using Route PCO for Approval (1.9.2.16). To route PCRs, use Route PCR for Approval (1.0.2.4). After a PCO is submitted, it can be approved with PCR/PCO Approval.

Once a PCR or PCO has been routed, the system restricts changes to the document to ensure that the approved document is the most current. If a routed PCR or PCO is accessed in the maintenance function, a warning displays. If you continue despite the warning, you can modify the PCO, but all approvals are reset to No, and each group on the routing must reapprove.

If a group disapproves a PCO and severity levels apply, the PCO can be rerouted to selected groups based on the severity of changes required. Only approvals of groups that need to review the document are reset.

Fig. 4.29

Route PCO for Approval (1.9.2.16)

Number	ID	Database	Title	By	Sub Date
PCO00001				mfg	
PCO00002				mfg	

Route PCO for Approval lists PCOs in order, beginning with the number you enter in the first frame. Select PCOs to display by PCO Type, Design Group, and By (Created By). Use Unsubmt Only to display unsubmitted PCOs, or set it to No to see both submitted and unsubmitted PCOs. Set Unsubmt Only to No if you want to revoke a submitted PCO.

Select a PCO for submittal, and set Sbmt to Yes in the bottom frame. The system displays a submit date for the PCO. To unsubmit a submitted PCO for which no approvals have been given, set Sbmt to No. A partially approved PCO must first have all electronic approvals changed from Yes to No. Once unsubmitted, additional changes can be made, and the approval cycle started again.

To attach comment pages, set Cmt to Yes.

Approving PCRs and PCOs

Approve PCOs using PCR/PCO Approval (1.9.6.1). Designated reviewers can enter electronic approvals or disapprovals, along with comments.

When Enforce PCO Approval Group Sequencing is Yes in PCC Control, users must follow the correct sequence during approval.

See page 110.

PCR/PCO Approval lists approval records by criteria you enter at the top of the screen. Enter a PCO number to have approvals listed starting with that PCO. Either PCRs or PCOs can be listed depending on the value entered in Document Type. When multiple approval records exist for a document, they are listed by approval sequence.

Specify an approval group to display only approvals required of that group. Specify a user ID to display only approvals required of groups that include that user.

Fig. 4.30
PCR/PCO Approval (1.9.6.1)

DocNbr	Appr Grp	Seq	Appr	ByReRT
PCO00001	ROUTE1	1	<input type="checkbox"/>	<input type="checkbox"/>
PCO00001	ROUTE2	2	<input type="checkbox"/>	<input type="checkbox"/>
PCO00001	ROUTE3	3	<input type="checkbox"/>	<input type="checkbox"/>
PCO00004	ROUTE1	1	<input type="checkbox"/>	<input type="checkbox"/>
PCO00004	ROUTE2	2	<input type="checkbox"/>	<input type="checkbox"/>

Doc Nbr	Title	Group	Appr	Cmt	ByReRT
PCO00001		ROUTE1	<input checked="" type="checkbox"/>	<input type="checkbox"/>	<input type="checkbox"/>

Unsigned Only. Enter Yes to display pending approvals. If Yes, documents are excluded from the display when only one of several groups has given approval.

Enter No to display both approved/disapproved and pending approvals. For each required approval, the group designated to perform the approval displays.

Appr. Enter No to disapprove previously approved PCOs. Enter Yes to approve previously disapproved PCOs.

Rerouting PCOs

If the reviewer disapproving a change document belongs to a group with Can Re-Route set to Yes on the routing slip, PCR/PCO Approval prompts for a reroute level. Reroute level signifies the magnitude of the problem noted by the reviewer. If you do not want to reset approvals, enter zero for the reroute level. Higher reroute levels require more groups to reapprove the document.

See “Defining Approval Routings” on page 114 for details.

When a reroute level is specified, the system examines Severity Level for each group on the routing slip. If Severity Level is less than or equal to the reroute level, the system changes the approval to No, indicating that the group must review the document again. To enter explanations for the reroute, set Comment to Yes.

When a document requires approval as a result of this process, the ByReRt field in PCR/PCO Approval is set to Yes.

Detail Approval Maintenance

To change or override the standard approval process, use Detail Approval Maintenance (1.9.6.13). Typically, this program is controlled with menu security, since it provides an administrative override to the standard approval function.

While it lets you override the normal approval process, it does not exactly duplicate it. For example, disapproved documents are not rerouted. To reroute, use PCR/PCO Approval.

Incorporating PCOs into Production

Once a PCO is approved, use the PCO Implementation menu (1.9.7) to update production data, as follows:

- 1 Use Release and Distribution (1.9.7.1) to release the PCO and notify members of the distribution group.
- 2 Use Incorporation Planning Report (1.9.7.3) to analyze the impact of the PCO on current inventory and help determine the best effective date for incorporation.
Note An enhanced version of Incorporation Planning Report is available at menu 1.9.7.27 for .NET UI users only.
- 3 Use Incorporation Selection (1.9.7.4) to specify an effective date.
- 4 Run Incorporation (1.9.7.5) on a daily basis to incorporate PCO changes into production records. Changes become effective on the date specified in step 3.
- 5 Run Implementation (1.9.7.13) on a daily basis to copy changes to item data records from PCOs effective on the current date into the item master records.

PCO Release and Distribution

After a PCO is approved, it is ready to be released and distributed. Releasing a PCO typically means transferring ownership of it from a design organization to a manufacturing or production organization. Distributing means notifying members of a distribution group of a PCO's release. This can be done with hard-copy reports or e-mail, depending on how the routing slip is set up.

Use Release and Distribution (1.9.7.1) to release and distribute PCOs. Release and distribution are initiated at the same time, but are recorded as separate points in the PCO life cycle. When a released PCO is distributed through a standard batch processing queue, significant time may elapse between release and actual distribution. Once a PCO is distributed, its release is final.

Note Since PCRs cannot be released to production, they are never listed on the screen.

Release and Distribution (1.9.7.1) lists PCOs by criteria entered at the top of the screen. Enter a PCO number to list PCOs beginning with that number.

Fig. 4.31
Release and Distribution (1.9.7.1)

Number	ID	Domain	Title	Rels	Cmt	Batch	ID
PCO00001				<input type="checkbox"/>	<input type="checkbox"/>	<input type="checkbox"/>	<input type="checkbox"/>
PCO00001				<input type="checkbox"/>	<input type="checkbox"/>	<input type="checkbox"/>	<input type="checkbox"/>
PCO00001				<input type="checkbox"/>	<input type="checkbox"/>	<input type="checkbox"/>	<input type="checkbox"/>
PCO00004				<input type="checkbox"/>	<input type="checkbox"/>	<input type="checkbox"/>	<input type="checkbox"/>
PCO00004				<input type="checkbox"/>	<input type="checkbox"/>	<input type="checkbox"/>	<input type="checkbox"/>
PCO00001				<input checked="" type="checkbox"/>	<input type="checkbox"/>	<input type="checkbox"/>	<input type="checkbox"/>

Unreleased Only. Enter Yes to view only unreleased PCOs. Enter No to view both released and unreleased PCOs, or to revoke a previously released, but not yet distributed, PCO.

Rels. Enter Yes to release the PCO, or No to unrelease it, assuming the PCO has been released but not yet distributed.

Batch ID. Specify a batch queue for printing release notices. Leave blank to print notices immediately. Since actual distribution of PCOs occurs only after reports are printed, queuing may result in lag time between release and distribution.

Incorporation Planning Report

Incorporation Planning Report (1.9.7.3) helps planning personnel evaluate the impact on inventory of implementing a PCO on a given effective date. To run the report, enter a specific PCO number, ID and/or domain, site, effective date, and cost method.

Note An enhanced version of Incorporation Planning Report is available at menu 1.9.7.27 for .NET UI users only.

Fig. 4.32
Incorporation Planning Report (Enhanced Version for .NET UI)

Field	Operator	Value	Action
Number	equals		+ x
ID	equals		+ x
Domain	equals		+ x
Site	equals		+ x
Effective Date	equals	12/15/2010	+ x
Cost Method (Current)	equals	GL	+ x

The report shows the summarized BOM/formula of each parent item from all product structure/formula records changed by the PCO. It lists components from all levels of the item's BOM or formula. The Qty Per values are extended to show the total quantity required per end item, rather than per single-level parent. This summary is similar to the Materials Summary Report (13.8.20).

Table 4.3 summarizes the information displayed for each component.

Table 4.3
Component Amounts

Information	Amount
Original Qty Req'd	Quantity per end-item for the currently effective product structures/formula records.
Final Qty Req'd	Quantity per end-item for product structure/formula records after the PCO has been implemented.
Qty On Hand	Current on-hand inventory balance for the component.
Qty On Order	Total quantity of supply on order for the component due on or before the entered effective date.
Projected Usage	Total demand quantity required for the component due on or before the entered effective date.
Balance	Total of Qty On Hand + Qty On Order – Projected Usage, yielding the component's expected on-hand inventory balance as of the entered effective date.
Value	Total monetary cost of the component inventory quantity in the Balance field, using the item costs associated with the entered Cost Method.

Use this report to estimate the future cost of obsolete inventory as of a given effective date. Run the report with different effective dates to determine which effective date minimizes inventory scrap/rework costs.

Typically, this report is considered in combination with other factors, such as the impact of changed routings/processes, new tooling, scrap and rework costs, purchased part lead times, and the mandatory date for the change. Nonetheless, future component inventory balances are relevant in almost all situations and provide valuable planning information.

Incorporation Selection

Use Incorporation Selection (1.9.7.4) to set PCO effective dates. Released and distributed PCOs display in order beginning with the PCO entered in the first frame. Enter criteria such as Type and Created By to show only PCOs matching those criteria.

Fig. 4.33
Incorporation Selection (1.9.7.4)

Number	PCO ID	Database	Title	Eff Date
PCO00004				
PCO0001				04/24/2007

Unincorporated Only. Enter Yes to view only PCOs that are distributed but not yet incorporated. Enter No to view all distributed PCOs.

If different PCOs change item master data for the same item, the system (and standard practice) requires them to be incorporated in revision level sequence. The system displays an error if you set PCO effective dates out of sequence or give more than one PCO the same effective date.

If a PCO has a mandatory date, a warning displays if the effective date is not on or before this mandatory date.

Incorporation

Once a PCO effective date is established, the PCO can be incorporated into product definition tables. At this point, you can still change PCO effective dates or even remove PCOs from the production system. Any incorporated PCO not yet implemented can be unincorporated or reincorporated by changing the PCO effective date.

Incorporation (1.9.7.5) updates the database with changes from PCOs for which effective dates have been set. Incorporation makes change data available to MRP, DRP, and the other preproduction modules.

Incorporation generates an audit trail report of database updates and any errors encountered. For example, if two PCOs with the same effective date update the same records, only changes from the first PCO are incorporated. The second is highlighted as an error on the report.

Assuming that Incorporation Selection has been run, PCO Incorporation is essentially a batch update process requiring no input from the user. Typically it is set up and executed as a daily batch job.

After incorporation, MRP and DRP automatically use the new effective dates in all planning processes.

Implementation

Once the effective date of a PCO is reached, the revision level of changed item numbers must be updated. This field displays in the Rev field of Item Data Maintenance.

Implementation (1.9.7.13) copies changes to item data records, from PCOs effective on the current date, into the corresponding item master records. Implementation is designed to be a daily batch job requiring no user input.

Closing PCR and PCOs

Use PCR/PCO Close (1.9.14) to close or reopen any PCO that has not been assigned an effective date in Incorporation Selection (1.9.7.4). You can close PCOs that have been released and distributed but not incorporated. Close undistributed PCOs in the trailer of PCO Maintenance. You can also use this program to close PCRs that are not closed by becoming part of a PCO.

See page 129 for details on PCO/PCR trailer fields.

Closed. If Yes, the PCR or PCO is closed. This field is reference-only, and does not establish a link to another PCO in the same way as Close PCO to PCO function in PCO Maintenance.

PCO Ref. Optionally, enter a value as a cross-reference.

Closing a PCR or PCO in this way makes a PCO available for export to another system database.

Importing and Exporting PCRs and PCOs

Use PCR/PCO Import/Export (1.9.13) to export closed PCO data to an ASCII file for import into another database or application, such as a Product Data Management system.

Fig. 4.34
PCR/PCO Import/Export (1.9.13)

The screenshot shows a software window titled "PCR/PCO Import/Export". The window has a menu bar with "Go To" and "ACTIONS". The main content area is divided into several sections. On the left, under "Import/Export:Export", there are input fields for "Number" (containing "PCO00001"), "ID", and "Domain". Below these is a text field for "Import/Export File" containing "ecdimplod.d". To the right of these fields are three "To:" labels, each followed by a small icon. At the bottom left, there are three checkboxes: "Re-Process" (unchecked), "Report" (checked), and "Update" (checked). At the bottom right, there is a label "Output:" followed by "Batch ID:".

Use the import function to restore archive files created by PCR/PCO Delete/Archive (1.9.15), which is similar to standard delete/archive programs.

Important You cannot restore PCR/PCO archive files using the standard Archive File Reload (36.16.5).

Re-Process. Only available when you are importing data. Enter Yes to have the Type and Design Group of imported PCRs and PCOs set to blank. The closed status is also removed and set to blank. This enables you to assign new types and design groups appropriate for the new domain. If No, a PCO with a Type and Design Group combination that does not exist in the new domain is not imported.

Setting Up PCC Security

Since PCC activities can affect your production environment, the following security steps are advised:

- Set Security in PCC Control to Yes for additional control of approvals. See “Setting Up PCC Control” on page 110 for details.

- Assign permission to PCR and PCO Maintenance programs to only one or a limited number of roles.

Access to PCO Maintenance Detail Functions

Each submenu in PCR and PCO Maintenance exists as a menu entry in the Product Change Utility menu (1.9.25). Granting permission to these menu items also grants permission to the corresponding submenu in PCR and PCO Maintenance.

Use the Role Maintenance functions (36.3.6) to create the appropriate roles and Role Permissions Maintain (36.3.6.5) to assign permissions.

Example If User1 does not have permissions for Item Data Maintenance (1.9.25.3), the Item Data Maintenance submenu does not display in PCR or PCO Maintenance.

Within the Item Data Maintenance submenu, access to individual update functions is controlled by permissions to corresponding application menus, since these functions directly update production data. This is unlike any of the other PCO sections where security is applied to the entire submenu based on access to the 1.9.25 menu number.

Table 4.2 on page 122 lists the application menus that correspond to the PCO and PCR update functions.

Restricting Access to Other Functions

Once PCC is implemented, prevent direct modification of controlled records by restricting permission to the following programs:

- For product structures, Product Structure Maintenance (13.5), Product Structure Copy (13.9), Component Change (13.10), Alternate Structure Maintenance (13.15), Configured Structure Maintenance (8.1)
- For routings, Routing Maintenance (14.13.1), Routing Maintenance (Rate Based) (14.13.2), Routing Copy (14.13.6), Routing Update (14.13.7)
- For formulas, Formula Maintenance (15.5), Formula Copy (15.8), Batch Quantity Change (15.9)
- For processes, Process Definition Maintenance (15.13), Process Definition Copy (15.16), Process/Formula Maintenance (15.18)
- For item specifications, Item Specification Maintenance (19.1.13)

Additionally, restrict permissions to Detail Approval Maintenance (1.9.6.13). Only use this program in situations that require immediate modifications of PCO approvals.

Regulatory Attributes

With the Regulatory Attributes module, companies can manage compliance with current Good Manufacturing Practices, with government regulations such as those from the FDA, and with international agreements such as NAFTA and GATT. The functions on the Controlled Substance menu associate customers, items, or sites with regulatory agency codes for import/export and international agreement compliance.

***Introduction to Regulatory Attributes* 140**

Introduces the features of the Regulatory Attributes module.

***Setting Up Regulatory Attributes* 141**

Discusses how to activate and configure Regulatory Attribute features using Regulatory Attributes Control.

***Defining Inventory Attributes* 143**

Discusses how to define inventory attributes.

***Using Work Order Batch Control* 150**

Discusses how to use batch control to assign batch numbers for reporting and traceability.

***Changing Inventory Detail Records* 151**

Explains how to use Multi-Lot Inventory Detail Update to change attributes for a particular item number and lot/serial combination.

***Using Lot Control* 152**

Outlines the use lot control features.

***Managing Component Issues* 162**

Illustrates how to use the options for restricting component items issued to work orders and to implement a similar control for receipts of co-product and by-product items.

***Managing Controlled Substances* 162**

Explains how to use the Controlled Substances features.

Introduction to Regulatory Attributes

This section includes a brief description of each feature of the Regulatory Attributes module. Features using other elements such as item data or user information may require setup in additional programs.

See “Setting Up Regulatory Attributes” on page 141.

Table 5.1
Regulatory Attributes Menu

Menu	Description	Program
1.22	Regulatory Attributes Menu	
1.22.1	Lot Master Maintenance	clltmt.p
1.22.2	Lot Master Inquiry	icltmiq.p
1.22.4	Work Order Attribute Maintenance	clatmt.p
1.22.5	Work Order Attribute Browse	clbr001.p
1.22.9	Work Order Batch Browse	clbr002.p
1.22.13	Lot Group Maintenance	cllgmt.p
1.22.14	Lot Group Browse	clbr005.p
1.22.16	Controlled Substances Menu	
1.22.19	Multi-Lot Inventory Detail Update	clltamt.p
1.22.22	Lot Master Build	clltbd.p
1.22.23	Lot Master Delete/Archive	clltup.p
1.22.24	Regulatory Attributes Control	clclpm.p

Note See “Managing Controlled Substances” on page 162 for Controlled Substances Menu details.

Site Security

Site security is not part of the Regulatory Attributes module, but is frequently used in conjunction with other compliance features. With site security, administrators can control user access to sites by individual and group membership. It integrates user maintenance and security control with inventory transactions at the site level. Only authorized users can process inventory transactions for secured sites.

Site Security Maintenance (36.3.13.8) is located on the System Security Menu. You can also use the programs on the Update Restrictions menu to create more detailed restrictions on transactions between locations and statuses.

See *User Guide: QAD Security and Controls* for details on site security.

Inventory Attributes

Attribute information that is entered on work orders increases control over the tracking of materials through manufacturing and into inventory. With these attributes, you can use batch and other work order processes to meet your business requirements. There are several ways to assign default inventory attributes and change existing attributes, such as assay percentage, grade, expire date, and inventory status.

Especially important is the ability to assign an inventory status during work order or purchase order receipt. This status can be used to override the status normally assigned to a location. Using receipt statuses reduces the need for separate physical locations for inventory subject to regulated business practices.

Note You do not need to have the Regulatory Attributes module to assign inventory statuses during receipt. However, this feature is especially useful in regulated environments.

Batch Control

Batch control enables you to assign batch numbers to work orders and then use them for traceability and reporting. You can enter batch numbers as you create work orders or add them to existing work orders through a maintenance function.

Component Issue Control

Features of the Regulatory Attributes module let you restrict items issued to work orders to those listed on the bill of material (BOM) or valid substitutes. There is a similar control for receipts of co-product/by-product items.

Lot Control

Using the lot control functions, you can enforce unique lot numbers, define lot groups for assigning lot numbers, update inventory attributes for multiple lots, restrict receipts to a single lot, generate reports with lot numbers as an index, enter supplier lot numbers, and manage expired inventory.

Multi-Lot Inventory Detail

You can change inventory assay %, grade, status, and expire date attributes based on lot/serial number.

Controlled Substances

You can maintain lists of regulatory agencies, link a regulatory or control number to an address code or site, associate a regulatory or control number to an inventory item, and record general ledger (GL) and individual license information for U.S. exports.

Setting Up Regulatory Attributes

Regulatory Attribute features are activated and configured in Regulatory Attributes Control (1.22.24).

Fig. 5.1
Features in Regulatory Attributes Control

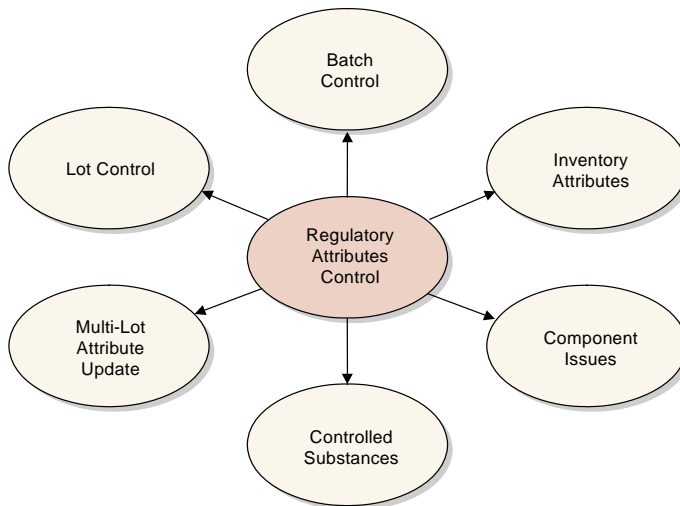

Use Regulatory Attributes Control, illustrated in Figure 5.2, to set up these features.

Fig. 5.2
Regulatory Attributes Control (1.22.24)

Compliance Active. Enter Yes or No depending on which features you want to use:

No: Only lot control features are active, based on the setting of Lot Control Level.

Yes: Work order attributes (including batch numbers), expired inventory transactions, and controlled substances are active.

Modify Component Issue. Enter Yes to issue any component to a work order. Enter No to restrict items issued to a work order to those listed on the work order bill of material (BOM) or valid substitute items.

Note Set up substitute items in Item Substitution Maintenance (13.19).

Modify Co/By-Product Receipts. Enter No to require all receipts to be valid items or substitute items for a co-product or by-product in a joint work order set. Enter Yes to allow any item to be received as an unplanned receipt.

Lot Control Level. Enter 0, 1, or 2.

0—Allow Duplicate Lot Numbers. Any lot number can be specified for any item number.

1–Unique Lot/Serial per Item Number. You cannot assign an item on an order a lot or serial number that is already used by that item on another order. For example, if work order WO1 assigns item A a lot number of 10, no other purchase or work order can assign lot number 10 to item A.

2–Unique Lot/Serial Numbers. You cannot assign an item a lot or serial number that is already used by another item in inventory. For example, if item A has a lot number of 10, item B cannot be assigned a lot number of 10. Rework work orders, expense work orders, and distribution orders do not have this restriction.

Single Lot per WO Receipt. Indicate whether work order receipts are restricted to a single lot.

No: Multiple receipts for an order can use the same lot number, if needed.

Yes: A new lot number is required for each receipt.

This setting determines the default for the Single Lot field of Work Order Receipts (16.11) and Work Order Receipt Backflush (16.12), where it can be changed as needed.

For more information on the effects of the Single Lot fields, see “Single Lot per Receipt” on page 160.

Note The Single Lot settings have no effect when Lot Control Level is set to 0.

Single Lot per PO Receipt. Indicate whether purchase order receipts are restricted to a single lot.

No: Multiple receipts for an order can use the same lot number, if needed.

Yes: A new lot number is required for each receipt.

This setting determines the default for the Single Lot field of Purchase Order Receipts (5.13.1), where it can be changed as needed. This setting also affects Returns to Supplier (RTS) in the Service/Support Management module. When this field is Yes and you have received an item lot, you cannot receive it again on an RTS.

Single Lot per REPET Receipt. Indicate whether end-item receipts in repetitive transactions are restricted to a single lot.

No: Multiple receipts for an order can use the same lot number, if needed.

Yes: A new lot number is required for each receipt.

This setting determines the default for the Single Lot field of Repetitive Labor Transaction (18.14), as well as Backflush Transaction (18.22.13) and Move Transaction (18.22.19) in Advanced Repetitive.

Defining Inventory Attributes

Attributes are critical to managing the flow of inventory in a warehouse. Of the various attributes, status is the most important, since you can restrict transactions based on status. When Compliance Active is Yes, you have more options for setting and using attributes.

Typically, the status of an item is determined by its location. In a regulated environment, a special status for quarantined items is often created and assigned to a particular location. Quarantined items are held in that location until they are inspected, approved for use, and transferred to a stocking location.

The use of separate physical locations may not be required, however, if items are marked for quarantine with some other method. For example, some companies use a removable label. You can use inventory statuses to support this business methodology.

To implement this practice, you first create a quarantine status in Inventory Status Code Maintenance (1.1.1). Then specify this status as the active default for purchase order and work order receipts in Item Master Maintenance. When items are received, the system assigns each lot a quarantine status, overriding the status of the location. After the lot is inspected and approved, the inventory status can be changed using Multi-Lot Inventory Detail Update (1.22.19). The lot no longer needs to be physically transferred to change its status.

Figure 5.3 illustrates setting inventory attributes in the work order Attributes frame. While batch and lot numbers are not technically attributes, they are located on the same frame so that they can be entered at order creation and updated during work in process. You can also set default inventory attributes for purchase orders and repetitive transactions.

Fig. 5.3
Work Order Maintenance (16.1), Attributes Frame

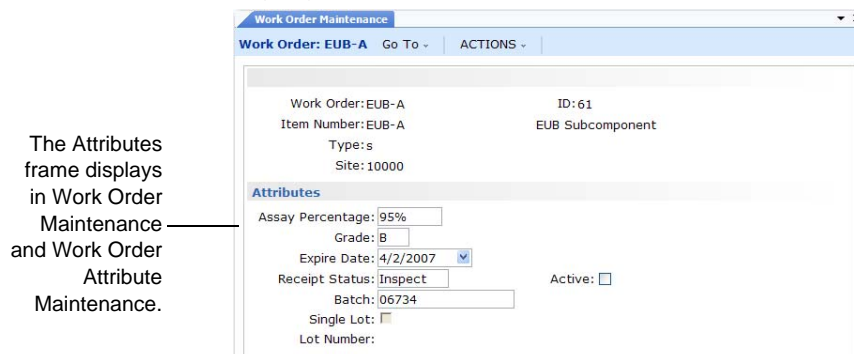

Work order attributes are stored in the work order master. When a work order is created, Receipt Status and Active default from Item-Site Inventory Data Maintenance (1.4.16). If Compliance Active is Yes, you can assign work order attributes, batch number, and lot number to end items in Work Order Maintenance (16.1). When Compliance Active is No and the item is lot controlled, only the Single Lot field can be modified.

When you receive items into inventory, you can modify assay %, grade, expire date, and receipt status, unless items with the same lot and reference numbers already exist in the location with different attributes. If you have not specified attributes on the work order and no inventory detail records exist, the system assigns default values from location or site records.

Note You can always modify attributes at receipt, regardless of the setting of Compliance Active.

Why Are Attributes Important?

While attributes are described here primarily for work orders, attributes also relate to purchase orders, repetitive transactions, and advanced repetitive transactions. Attributes you enter on an order eventually are assigned to inventory records during order receipt—whether it is a purchase order, work order, or repetitive transaction. The only difference among order types is where in the order process the attributes are assigned.

The inventory status attribute can be defined for any unique combination of item number, site, location, lot/serial, and reference. The following table describes which attributes can be defined for each order type and indicates the programs where you define them.

See “Inventory Attribute Active Field” on page 147.

Table 5.2
Defining Attributes

Order or Attribute Type	Menu	Attributes
Work Order	Work Order Maintenance (16.1) Work Order Attribute Maintenance (1.22.4) Work Order Receipts Pop-Up Window (16.11)	Assay% Grade Expire Date Receipt Status/Active
Purchase Order	Purchase Order Receipts Pop-Up Window (5.13.1)	Assay% Grade Expire Date Receipt Status/Active
Repetitive	Repetitive Labor Transaction Pop-Up Window (18.14) Backflush Transaction Pop-Up Window (18.22.13) Move Transaction Pop-Up Window (18.22.19)	Assay% Grade Expire Date Receipt Status/Active
Inventory Status	Item-Site Inventory Data Maintenance (1.4.16) Item Inventory Data Maintenance (1.4.5) Item Master Maintenance (1.4.1)	PO Rcpt Status WO Rcpt Status
Inventory Status	Location Maintenance (1.1.18) Site Maintenance (1.1.13)	Inventory Status

You can use the two programs in boldface type to modify attributes only when Compliance Active is Yes.

Note You can change inventory attributes only for purchase orders with a blank type. This restriction excludes blanket purchase orders and PO returns.

Inventory Attributes Workflow

Once Compliance Active is Yes in Regulatory Attributes Control, you can create and process work orders according to your normal procedures. If needed, you can update item attributes directly using Work Order Attribute Maintenance (1.22.4).

Fig. 5.4
Inventory Attributes Workflow

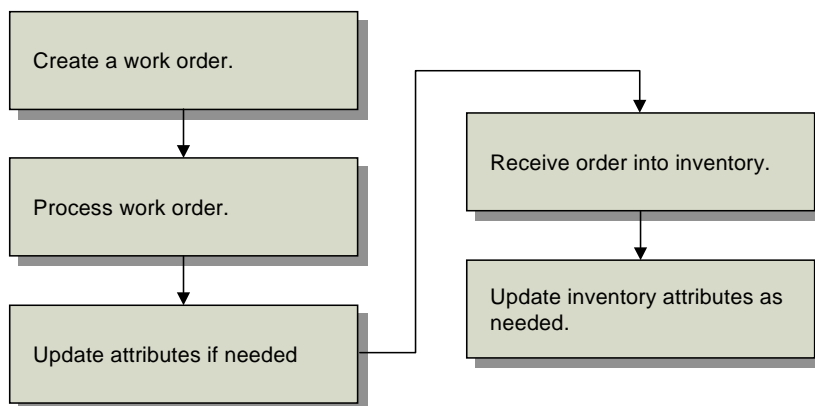

Then receive the work order using Work Order Receipt (16.11) or Work Order Operation Backflush (16.19). After the items have been received, attributes can be modified again as needed using Multi-Lot Inventory Update (1.22.19) or Inventory Detail Maintenance (3.1.1).

Attribute Descriptions

Table 5.3 lists work order attributes. Each attribute is a field in Work Order Attribute Maintenance (1.22.4) and the Attributes frame of Work Order Maintenance (16.1). Attributes, lot number, and batch number also appear in receipt programs and other programs.

Table 5.3
Attribute Descriptions

Attribute	Description	Usage
Assay%	The presence, absence, or quantity of one or more components, usually expressed as a percentage.	Formulations may require a minimum assay percentage. These values are reviewed prior to allocating or picking stock from inventory.
Grade	Identifies the quality or physical properties of an inventory quantity. Graded products include raw materials, intermediates, and finished goods.	Formulations may require a minimum grade. These values are reviewed prior to allocating or picking stock from inventory. Grade may determine the price charged for the finished product.
Expire Date	The expiration date for items that eventually spoil, and for pharmaceuticals that lose potency over time.	If you try to allocate, ship, or issue expired inventory, you get an error message. If expired inventory is recertified, assign a new expiration date in Inventory Detail or Multi-Lot Attribute Update.
Receipt Status	The default receipt status for the order.	Items may require a status assigned to them upon receipt. For example, dangerous or fragile items may need quarantine or inspection before shipment or component issue. Define status codes in Inventory Status Code Maintenance (1.1.1).

Attribute	Description	Usage
Active	Indicates whether the inventory status code entered in Receipt Status should override status assigned in item, site, and location data.	Use this field to override default settings assigned in item, site, and location data records. See “Inventory Attribute Active Field” on page 147 for more information.
Batch	An arbitrary number for tracking a quantity scheduled to be produced or in production. See “Using Work Order Batch Control” on page 150 for information on using batch numbers.	You can use batch numbers for tracking a group of lots or a portion of a lot. The system does not validate batch number, but you can report on batches with Work Order Batch Browse (1.22.9).
Single Lot	Determines whether each receipt from a work order should be assigned to a single lot. This is a default setting you can change at receipt. Single Lot also appears in Purchase Order Maintenance. See “Using Lot Control” on page 152 for details.	For additional control, you can force each receipt to be received into a single lot by setting to Yes. If the order is for a serialized item, this field is automatically set to Yes and cannot be changed. You cannot change this setting under the following conditions: once items have been received against this order (line item for POs), for rework or expense work orders (type R or E), or if the order is part of a joint work order set.
Lot Number	The lot number for this work order. Enter a lot number in this field. See “Using Lot Control” on page 152 for information on using lot numbers.	When Single Lot is No, you can enter a lot number for this work order. The system validates this field for uniqueness when Lot Level is set to 1 or 2. With the above conditions met, entering a lot number at order reserves that number in the lot master.

Inventory Attribute Active Field

You can override inventory status and other attribute information for an item during receipt, *except* when the status or other attribute conflicts with existing items with the same lot and reference number at a location. When this occurs, an error displays and you have two choices:

- Change the site, location, lot, and reference to identify a different inventory location.
- Change the Active field of the inventory status or other attribute to No. The system then uses the attribute of the already existing inventory detail record.

Overriding Default Attributes

To override attributes at receipt, set the Set Attributes field to Yes in Work Order Receipt (16.11), Work Order Operation Backflush (16.19), Purchase Order Receipts (5.13.1), Repetitive Labor Transaction (18.14), Backflush Transaction (18.22.13) and Move Transaction (18.22.19) in Advanced Repetitive, or RTS Receipts (11.7.3.13).

Fig. 5.5
Set Attributes Field in Work Order Receipt (16.11)

A pop-up window displays the current attribute settings.

Fig. 5.6
Receipt Attributes Pop-Up

Change attributes as needed and choose Yes in the associated Active field to use your selections.

- Choose Yes in the Use As Default field to assign the entered attributes as defaults for the current order. All future receipts to the same order will have the specified attributes.
- Choose No in all of the Active fields and choose Yes in the Use As Default field to clear the default values. All attribute values are set to blank for this order.
- If inventory exists for a location, lot, and reference combination with attributes that are different from the ones on this order, an error message displays. Choose No in the Active fields of the conflicting attributes to correct the error.

Active Fields and Blank Inventory Status

Active fields enable you to enter a blank for a valid inventory status. For example, if the PO Rcpt Status field is blank, the system cannot determine whether you want to assign a blank status code, or if you want to accept a default setting previously assigned to an item, location, or site. The Active field solves this problem. If the Status field is blank and Active is Yes, then a blank status is assigned. Otherwise, if the Status field is blank and Active is No, the system assigns the status based on another default, as described in Table 5.4.

Attribute Order of Precedence

Table 5.4 shows the search order the system uses to determine default inventory attributes during receipt. If values have not been defined in any of these programs, the default attribute is blank.

Table 5.4
Attribute Search Order

Order of Precedence	Location of Inventory Status Values	Menu Number	Field Name	Active
1	Work Order Maintenance	16.1	Receipt Status	Yes
	Work Order Attribute Maintenance	1.22.4	Receipt Status	Yes
2	Item-Site Inventory Data Maintenance	1.4.16	PO Rcpt Status	Yes
			WO Rcpt Status	Yes
3	Item Master Maintenance	1.4.1	PO Rcpt Status	Yes
			WO Rcpt Status	Yes
4	Inventory Detail Maintenance	3.1.1	Inventory Status	N/A
5	Location Maintenance	1.1.18	Inventory Status	N/A
6	Site Maintenance	1.1.13	Inventory Status	N/A

Figure 5.7 illustrates how these rules can be applied. In this example, assume that all of the items are in the same lot and have the same reference number.

Item A, which has a default inventory status of 5, cannot be received into Location L. This is because the same item already exists in this location with the same lot and reference numbers and a different status. Item A *can* be received into Locations M or N with a status of 5, since neither of these locations contains inventory with the same lot or reference number as the items being received.

If Item A's Active field were No, it could be received into Locations L, M, or N. In this case, Item A's status would change to the default status for the location—2 for Location L, 3 for Location M, 4 for Location N.

Fig. 5.7
Inventory Status Example

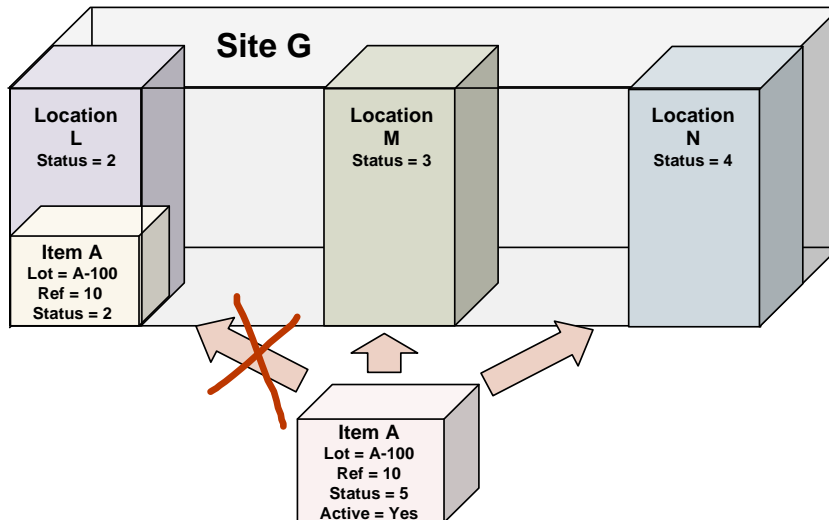

Using Work Order Batch Control

Batch numbers group and categorize work orders. Use batch control to assign batch numbers to work orders for reporting and traceability based on regulatory attributes. You can assign the same batch number to a group of work orders run through a single manufacturing process. You can assign one batch number per work order receipt session. If you have multiple batches on a single work order, use a different receipt for each batch.

Batch traceability is a single-level function. It identifies work orders associated with a batch number. Lot and serial numbers are used to identify, report on, and trace inventory transactions. A lot number is unique to a given finished product or collection of components that make up a finished product. Use lot traceability to identify work order components. A batch number cannot be used for scheduling, planning, or shop floor reporting.

Example A pharmaceutical manufacturer makes acetaminophen powder in large quantities. Each run results in a batch of acetaminophen powder ready for processing into tablets—a batch with an assigned number that uniquely identifies its origin. This batch is the tablet processing source that is packaged in various sized bottles, each labeled with a lot number. The lot number uniquely identifies the item in inventory, traceable by work order receipt, which in turn uniquely identifies the work order and its batch number.

Batch Control Workflow

This shows a typical workflow for managing batches.

Fig. 5.8
Batch Control Workflow

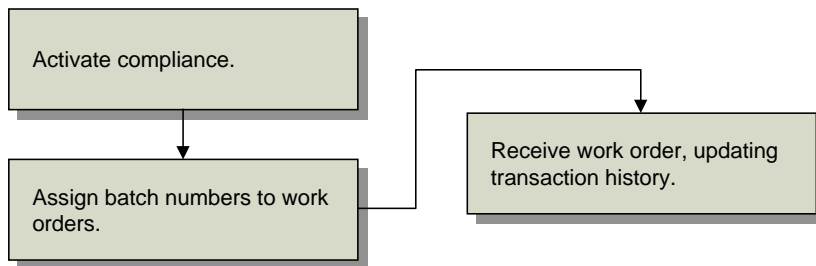

Once Compliance Active is Yes in Regulatory Attributes Control, you can assign batch numbers to work orders directly in Work Order Maintenance or use Work Order Attribute Maintenance (1.22.4). When the work order is received, the batch number is stored in inventory transaction history for later reporting.

Assigning Batch Numbers to Work Orders

You will probably assign the batch number when you assign work order attributes during work order creation. You can also use Work Order Attribute Maintenance to assign numbers.

When you receive the items into inventory with Work Order Receipts (16.11) or Work Order Operation Backflush (16.19), batch numbers are recorded in transaction history.

You can review batch numbers using:

- Transactions Detail Inquiry (3.21.1)

- Transactions Detail Report (3.21.25)
Note This enhanced report is available only through QAD .NET UI.
- Reports on the Work Order Reports Menu (16.3)
- Reports on the Lot/Serial Number Menu (3.22)

The programs listed in Table 5.5 use or list batch numbers.

Table 5.5
Programs Using Batch Numbers

Menu	Number
Transactions Detail Inquiry	3.21.1
Transactions Detail Report (.NET UI)	3.21.25
Lot Transactions by Date Browse	3.22.1
Lot Actual Bill Inquiry	3.22.3
Lot Where-Used Inquiry	3.22.4
Work Order Batch Browse	1.22.9
Work Order by Order Report	16.3.1
Work Order by Item Report	16.3.2
Work Order Status Report	16.3.3
Work Order History Report	16.3.6
Work Order Release Print	16.6
Multiple Work Order Release Print	16.7
Work Order Split	16.9

Changing Inventory Detail Records

Use Multi-Lot Inventory Detail Update (1.22.19) to change assay %, grade, status, and expire date attributes for a particular item number and lot/serial combination.

Warning Use this feature with caution. The only way to restore old inventory attribute values is to reassign them using this update. If you change all values for a record type to a new value, you cannot recover the original values.

Assay %, grade, expire date, and inventory status can have field security implemented to limit access to any or all of the fields. Use Field Security Maintenance (36.3.15.1) to enter the names of fields you need to restrict. Users must have explicit authority to access secured fields.

Use the following procedure to update inventory detail records:

- 1 Choose Multi-Lot Inven. Detail Update (1.22.19) from the Regulatory Attributes Menu.

Fig. 5.9
Multi-Lot Inven. Detail Update (1.22.19)

Enter appropriate selection criteria.

Enter values to change in Old Value column.

Enter replacement values in the New Value column.

- 2 Enter a value in Item Number. The first lot number displays if inventory exists for this item.
- 3 Use the lot number that displays, enter a new lot number, or clear the Lot/Serial field to update items with blank lot/serial numbers.
- 4 Enter, singly or by range, sites, locations, and references for which you have access privileges.

Note Leaving Site, Location, or Ref blank changes inventory attributes for all sites, locations, and lot references.
- 5 Enter old attribute values, set the All fields, and enter new attribute settings in the lower half of the frame.

Old Value. Enter the value to be changed.

All. If Old Value is blank and All is Yes, all values are changed to New Value. If Old Value is blank and All is No, only blank values are changed to the New Value. The field defaults to No. You can change it to Yes only when Old Value is blank.

New Value. Enter the replacement value for the field.

- 6 Set Update to No and run the program as a report first to make sure you have entered the correct values.
- 7 When you are satisfied with the new values and the item, lot, and site data listed on the report, change Update to Yes and run the program again.

Using Lot Control

You can use lot control features even if Compliance Active is No in Regulatory Attributes Control. Table 5.6 lists lot control features.

Table 5.6
Lot Control Features

Feature	Description
Lot Control Level	Controls enforcement of unique lot numbers. Lot Control Level is a database-level setting. See “Setting Up Regulatory Attributes” on page 141 and “Deciding on Lot Control Level” on page 155 for more information. If you set Lot Control Level to 0, all lot controls are turned off.
Work Order Attribute Lot Number Field	You can enter the lot number in the Work Order Attributes frame when Single Lot is No. See “Defining Inventory Attributes” on page 143 for more information.
Lot Groups and Auto Lot Numbering	Define lot groups to assign lot numbers to work orders and purchase orders automatically. See “Automatic Lot Numbering” on page 158 for more information.
Single Lot Receipts	Restrict receipts to a single lot, with separate settings for work orders, purchase orders, and repetitive transactions. See “Single Lot per Receipt” on page 160 for more information.
Expired Inventory Management	Manage expired inventory transactions. See “Expired Inventory Transactions” on page 161 for more information.
Supplier Lot Numbering	Enter supplier lot numbers on purchase order receipts. See “Supplier Lot Numbers” on page 161 for more information.
Reports by Lot Number	Make reports using lot numbers as an index.

When implementing lot control, be aware of the following restrictions:

- Lot control cannot enforce lot uniqueness across multiple databases. Multiple-database customers should integrate policies to maintain lot number uniqueness for each database.
- Lot numbers cannot be reused. If you make an error during lot number assignment, delete the record for that lot number in Lot Master Maintenance (1.22.1), and then reassign it.
- The system cannot correct duplicate lot numbers assigned prior to lot control activation. Delete duplicate lot numbers using Lot Master Delete/Archive (1.22.23).

Lot Control Workflow

This shows a typical workflow for setting up and managing lots.

Fig. 5.10
Lot Control Work Flow

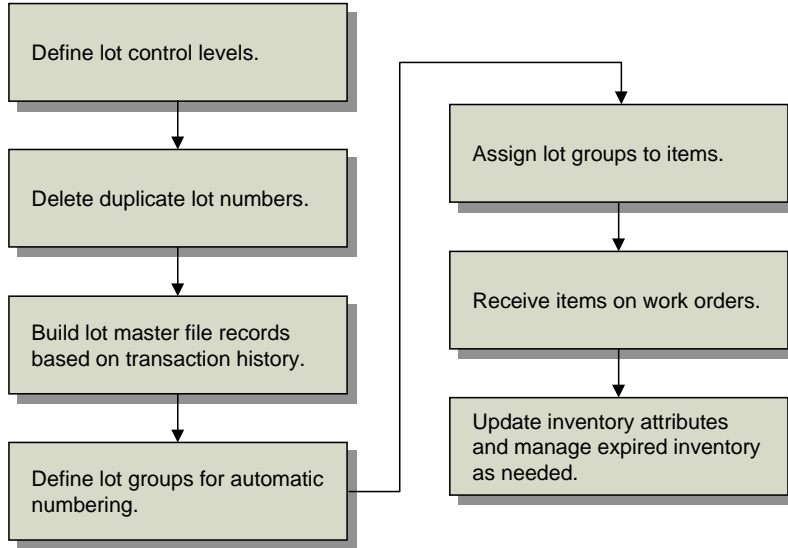

To implement lot control, define defaults in Regulatory Attributes Control for purchase orders, work orders, and repetitive. Then delete any existing duplicate lot numbers using Lot Master Delete/Archive (1.22.23). Use Lot Master Build (1.22.22) to create lot master records for all lots referenced in transaction history.

Then define the lot groups needed to generate automatic numbers using Lot Group Maintenance (1.22.13). When the groups have been established, associate them with the appropriate items using Item Inventory Data Maintenance (1.4.5) or Item Master Maintenance (1.4.1).

When items are received on work orders, purchase orders, or repetitive orders, the system generates lot numbers automatically. You can update inventory attributes and manage expired inventory as needed using Multi-Lot Inventory Update (1.22.19) or Inventory Detail Maintenance (3.1.1).

Lot Control Relationships

The settings described in Figure 5.11, along with the auto-lot settings in Item Master Maintenance (1.4.1), affect lot numbering on several levels.

Fig. 5.11
Lot Control Hierarchy

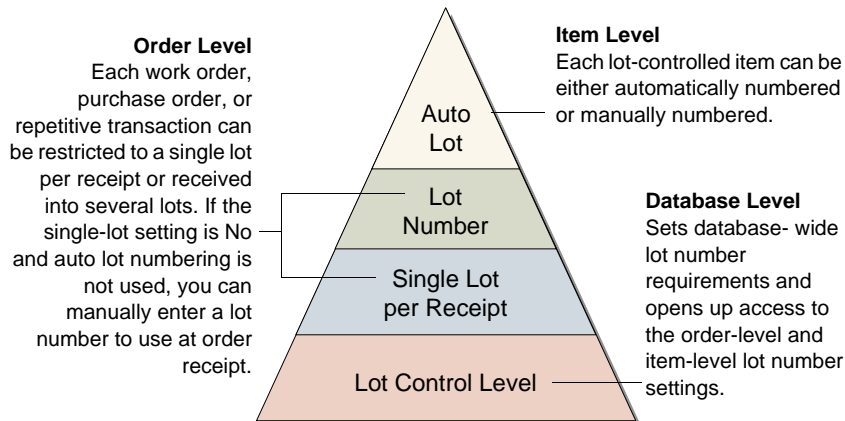

Lot Control Level

This database-level setting is the most straightforward to employ. If you want to use single lot per receipt settings, Lot Control Level must be 1 or 2. If you do not want to use either of these features, you can still use Lot Control Level to control lot number uniqueness for each item (level 1) or across all items in inventory (level 2).

Single Lot per Receipt and Lot Number Field

If you select level 1 or level 2 lot control, then you can use single-lot settings. You can have a different default setting for work orders, purchase orders, and repetitive transactions. Further, the single-lot setting can be changed for each order at the time of receipt. A receipt lot number can be specified in the Work Order Attributes frame when the single-lot setting is No and auto lot numbering is not used.

Auto Lot Numbering

Automatic lot numbering works with any lot level setting. Since automatic lot numbering is set for each item, you can choose to have some items auto numbered and some not.

Deciding on Lot Control Level

Table 5.7 shows five different ways of combining lot control features.

Table 5.7
Lot Control Settings

Example	Lot Control Level	Single Lot	Lot No.	Auto Lot No.	Effect
1	0	–	–	Y	When Lot Control Level is 0, none of the lot control features work.
2	1	Y	–	Y	Items with the same item number cannot have the same lot number; orders are restricted to a single lot by default, the lot number field in work order attributes is inaccessible, and the item is auto numbered.
3	2	Y	–	Y	Lot numbers across all items must be unique. The remainder is the same as example 2.
4	1	N	+	Y	Items with the same item number cannot have the same lot number; orders are not restricted to a single lot by default, the item is auto numbered, and the lot number value in work order attributes is set by the system and cannot be changed.
5	2	N	+	N	Lot numbers across all items must be unique; orders are not restricted to a single lot by default, the lot number field in work order attributes <i>is</i> accessible, and the item is not auto numbered.

Building Lot Master Records

You must run Lot Master Build (1.22.22) whenever:

- Lot Control Level is changed from 0 to either 1 or 2.
- Archived records are loaded back into the inventory transaction history table.

Lot Master Build creates lot master records based on inventory transaction history. These records represent a historical list of all lot and serial numbers used in the system. Whenever you assign a new lot or serial number and Lot Control Level is 1 or 2, the system automatically updates the lot master.

Fig. 5.12
Lot Master Build (1.22.22)

You can enter any combination of item number, date, and transaction ID ranges. Before updating the database, set Update to No to generate a listing of changes that will be made. Review the listing to verify that it is correct. Then rerun the program with Update set to Yes.

Modifying Lot Master Records

Use Lot Master Maintenance (1.22.1) to manually add, modify, or delete lot master records. Adding records is not recommended, since the records created with this program are not associated with an order, limiting the traceability.

This function is typically used to add additional data. Many user-defined fields are provided to support custom reporting requirements.

Fig. 5.13
Lot Master Maintenance (1.22.1)

Dtefld	Chrflid	Decfld
Dtefld 1:	Chrflid 1:	Decfld 1: 0.00
Dtefld 2:	Chrflid 2:	Decfld 2: 0.00
Dtefld 3:	Chrflid 3:	Decfld 3: 0.00
Dtefld 4:	Chrflid 4:	Decfld 4: 0.00
Dtefld 5:	Chrflid 5:	Decfld 5: 0.00
Dtefld 6:	Chrflid 6:	Decfld 6: 0.00

Specify an item number and lot/serial number. When you click Next, the system displays the order number and line or ID that created the lot or serial number. The date the record was created and the ID of the user creating the record also display.

You can update the following fields:

Expired Inv Trans. An inventory transaction type allowed for executing transactions on expired inventory for this item and lot number.

Lot UM. An alternate unit of measure for this specific lot. This field is for reference only.

Lot UM Conversion. A factor for converting the Lot UM to the item unit of measure. This field is for reference only.

Automatic Lot Numbering

Use Lot Group Maintenance (1.22.13) to create lot groups defining the format for automatic lot numbering. You can restrict lot groups to individual sites or they can apply to all sites. Assign lot groups to items in Item Master Maintenance (1.4.1), Item Inventory Data Maintenance (1.4.5), or Item Master Copy (1.4.12).

If a lot group record is altered or removed after lot numbers have been generated, the continuity of lot numbers will be broken. Additionally, automatically generated lot numbers are not recycled if they are not used at the time they are assigned. It is possible for gaps to appear in the sequencing of auto lot numbers if, for example, a receipt transaction is canceled before inventory is received.

Fig. 5.14
Lot Group Maintenance (1.22.13)

The screenshot shows a window titled "Lot Group Maintenance" with a menu bar containing "Go To" and "ACTIONS". The main area contains the following fields:

- Lot Group: Bulk
- Site: 10000
- Leading Characters: BLK
- Sequence Length: 5
- Sequence Number: 1
- Trailing Characters: AUTO
- Execution File: gpauto01.p

Lot Group. Assign a name to the automatic lot numbering format. Name can be up to eight alphanumeric characters.

Site. Enter a value if you want this lot group to be used at one site only. Leave blank if the lot group can be applied to any site.

Leading Characters. Enter up to 12 characters to be placed at the beginning of the lot number. Can be left blank. The lot number, including leading characters, sequence number, and trailing characters, can be up to 18 characters long.

Sequence Length. Enter a number between 5 and 10. This is the length of the numeric portion of the automatic lot numbers.

Sequence Number. The default is 1. Enter the first number to be used in automatic lot numbering. The lot number consists of this number, plus leading and trailing characters.

The smallest number available for assignment is 00001 and the largest is 999999999. If you are using a six-digit sequence length, you may want to start automatic lot numbers with 100000 instead of 1. This number increments by 1 when numbers are assigned.

Trailing Characters. Enter up to 12 characters to be placed at the end of the lot number. Can be left blank.

Execution File. The program to execute when assigning automatic lot numbers. The default is `gpauto01.p`, the standard program supplied with the system. You can create custom programs to assign lot numbers based on your own requirements.

Assigning Lot Groups to Items

Use one of the item maintenance programs to set up items for automatic lot numbering:

- Item Master Maintenance (1.4.1)

- Item Inventory Data Maintenance (1.4.5)
- Item Master Copy (1.4.12)

Fig. 5.15
Item Master Maintenance (1.4.1)

Three fields affect automatic lot numbers:

Lot/Serial Control. Automatic lot numbering only works with lot-controlled items (set to L). It does not work with serial-controlled items.

Auto Lot Numbers. Yes activates automatic lot numbering for this item if L is selected in Lot/Serial Control.

Lot Group. An optional lot group format. If Lot Group is blank, Lot/Serial Control is L, and Auto Lot Numbers is Yes, work orders are assigned a lot number equal to the Work Order ID. However, lot numbers must be entered manually on purchase order and repetitive receipts in this case. See “Automatic Lot Numbering” on page 158.

Creating Automatic Lot Numbers

When receipts are created for purchase orders and work orders that contain items set up for automatic lot numbering, the system generates a lot number according to the Lot Group format assigned to the item. The lot number cannot be changed. The following programs assign automatic lot numbers:

- Purchase Order Receipts (5.13.1)
- RTS Receipts (11.7.3.13)
- Work Order Receipt (16.11)
- Work Order Receipt Backflush (16.12)
- Work Order Operation Backflush (16.19)
- Repetitive Labor Transaction (18.14)
- Backflush Transaction (18.22.13)
- Move Transaction (18.22.19)

Note Rework and expense work orders cannot be assigned automatic lot numbers.

Single Lot per Receipt

Receipts can be restricted to a single lot number by default on work orders, purchase orders, and repetitive orders, based on three settings in Regulatory Attributes Control (1.22.24):

- Single Lot Per WO Receipt (work order receipt)
- Single Lot Per PO Receipt (purchase order receipt)
- Single Lot Per REPET Receipt (repetitive receipt)

Note The single lot restriction can also be selected during order receipt, regardless of the setting in Regulatory Attributes Control.

To use single lot receipts, Lot Control Level must be 1 or 2 and Lot/Serial Control must be L or S for the item being received.

If these criteria are met and Single Lot is Yes on the order or line being received:

- Items received in the same transaction must have the same lot number.
- Each receipt transaction requires a new lot number.

Set Single Lot to No to allow the same lot number to be used for multiple receipts. The single lot restriction works the same way for all three order types, so you can adapt the settings to your needs.

Note When Auto Lot Numbers is Yes and a lot group is specified in the item master, the system automatically increments the numeric portion of the lot number for each successive receipt against the same order or line. This means that you cannot receive the same lot in multiple receipt transactions or receive multiple lots in the same transaction, regardless of whether Single Lot is Yes. For more information, see “Automatic Lot Numbering” on page 158.

During order entry, you can modify the default value of Single Lot in any of the following programs:

- Purchase Order Maintenance (5.7)
- Blanket Order Maintenance (5.3.1)
- Work Order Maintenance (16.1)
- Work Order Attribute Maintenance (1.22.4)
- Repetitive Labor Transaction (18.14)
- Backflush Transaction (18.22.13)
- Move Transaction (18.22.19)

Supplier Lot Numbers

The Supplier Lot field is a reference field for entering supplier lot numbers in Purchase Order Receipts (5.13.1).

Fig. 5.16
Purchase Order Receipts (5.13.1)

The screenshot shows the 'Purchase Order Receipts' window for Purchase Order 01DMPO. It displays a table of items and a form for line 1. The Supplier Lot field is highlighted with a callout.

Ln	Item Number	UM	Qty Open	UM	Receipt Qty	UM	Project	Due Date	T
1			450.0	CS	0.0	CS		02/14/2007	M
2	100C	EA	500.0	EA	0.0	EA		02/14/2007	

Form fields for Line: 1:

- Unit of Measure: CS
- Site: BE4
- Loc: []
- Quantity: 0.0
- ID: []
- Lot/Ser: []
- Packing Qty: 0.0
- OP: 0
- Reference: []
- Supplier Lot: 5700
- Cancel B/O:
- Item Number: []
- Multi Entry:
- Chg Attribute:
- Supplier Item: []
- Cmnts:

One supplier lot number can be assigned for each lot received. For example, if you have two supplier lot numbers, you cannot receive both into the same internal lot number. There are two alternative ways to handle this situation:

- Receive each supplier lot number to a different location. Then you can assign the same internal lot number to each.
- Receive the first supplier lot and complete the receipt transaction; then perform a second receipt.

To review and report on supplier lot numbers, use the Supplier Lot field in the following programs:

- Transactions Detail Inquiry (3.21.1)
- Transactions Detail Report (3.21.25, .NET UI only)
- Lot Where-Used Inquiry (3.22.4)

Expired Inventory Transactions

When lot-controlled items expire, you may want to remove them from inventory. Inventory is expired if it has an expiration date before today. Expired inventory cannot be sold or issued for manufacturing. However, for lot-controlled items, you can specify a transaction type that can occur for any expired items in a lot.

Lot Control Level must be 1 or 2 before you can use expired inventory features.

Example If you enter ISS-UNP (Unplanned Issue), the system lets you make an unplanned issue transaction, even though inventory has expired. This is true only for the item number and lot number identified on this lot master record. See “Setting Up Regulatory Attributes” on page 141.

Use the Expired Inv Trans field in Lot Master Maintenance (1.22.1) to specify this transaction type. See “Modifying Lot Master Records” on page 157.

Managing Component Issues

The Regulatory Attributes module provides options for restricting component items issued to work orders to those on the product structure or defined as valid substitutes. You can implement a similar control for receipts of co-product and by-product items.

See “Setting Up Regulatory Attributes” on page 141.

Component Issue Control

Use the Modify Component Issues field in Regulatory Attributes Control (1.22.24) to control issues to work orders. Set this field to No to require that all items issues are on the work order BOM or are valid substitute items. Choose Yes to allow any item to be issued to the work order.

Valid substitute items are defined in Item Substitution Maintenance (13.19). When Modify Component Issues is No, issues are allowed for those items with valid substitutes.

Co-product/By-product Component Issue Control

Use the Modify Co/By-Product Receipts field in Regulatory Attributes Control to control receipts for co-products and by-products.

- Set this field to No to require all receipts to be valid items or substitute items for a co-product or by-product in a joint work order set.
 - Note** Items entered through Work Order Bill Maintenance (16.13.1) can be issued to a work order regardless of control program settings.
- Choose Yes to allow any item to be received as an unplanned receipt.

Managing Controlled Substances

Controlled substance programs, tables, and fields do not interfere with functions in other modules.

The functions on the Controlled Substance menu, listed in Table 5.8, are used to record Health Industry Numbers (HIN), National Drug Codes (NDC), Export Control Classification Numbers (ECCN), Harmonized Tariff Codes, Regional Value Content (RVC) values, and Preference Criteria Codes for controlled substances, import/export, and international agreement compliance.

Table 5.8
Controlled Substances Menu (1.22.16)

Menu	Description	Program
1.22.16	Controlled Substances Menu	
1.22.16.1	Controlled Authority Maintenance	clctamt.p
1.22.16.2	Controlled Authority Browse	clbr009.p
1.22.16.4	Controlled Customer Maintenance	clctcmt.p
1.22.16.5	Controlled Customer Browse	clbr003.p
1.22.16.7	Controlled Site Maintenance	clctsmt.p
1.22.16.8	Controlled Site Browse	clbr004.p
1.22.16.10	Controlled Item Maintenance	clctpmt.p
1.22.16.11	Controlled Item Report	clctprp.p

Menu	Description	Program
1.22.16.13	General License Maintenance	clglimt.p
1.22.16.14	General License Report	clglirp.p
1.22.16.15	General License Browse	clbr008.p
1.22.16.16	Individual License Maintenance	clilimt.p
1.22.16.17	Individual License Master Report	clilirp.p

The figure shows a typical workflow for setting up and managing controlled substances.

Fig. 5.17
Controlled Substances Work Flow

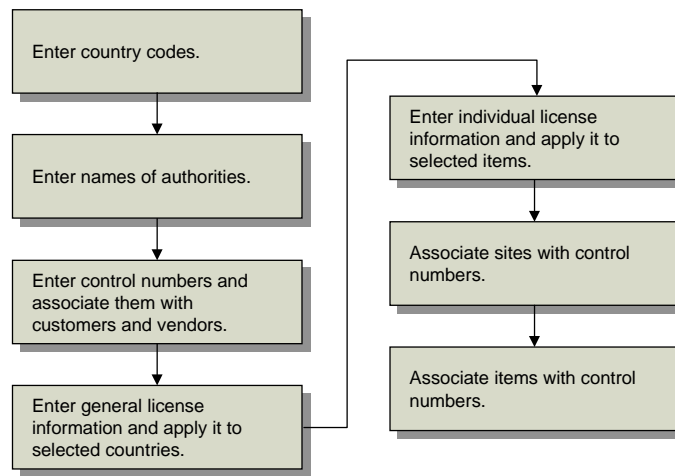

Entering Country Codes

Use Country Code Data Maintenance (2.14.1) to define information about a country’s membership in international organizations and their DEA status. You can also categorize countries by assigning each one to a country group using a coding system—such as the US Export Administration codes.

See “Setting Up Country Code Data” on page 181.

Entering Authority Codes

Enter authorities in Controlled Authority Maintenance (1.22.16.1). These authorities are assigned, along with country codes, to customers, sites, and items.

Fig. 5.18
Controlled Authority Maintenance (1.22.16.1)

Controlled Authority Maintenance: Go To - ACTIONS -

Authority: US-COM
 Name: U.S. Commerce Commission
 Type: Export
 Group:
 Comments:

Authority. Enter a descriptive acronym or short name, up to eight characters long. For example, enter DEA for Drug Enforcement Administration or WHO for World Health Organization.

Name. Enter the full name for the authority.

Type, Group. Enter values to further categorize authorities on reports.

Entering Control Numbers for Customers and Sites

Use Controlled Customer Maintenance (1.22.16.4) to associate control numbers with customers and vendors. Use Controlled Site Maintenance (1.22.16.7) to associate control numbers with sites. These two programs are the same except that you enter an address code in the first and a site code in the second.

These programs can be used to store many types of codes, such as codes associating a DEA number with a customer, foreign tax identification numbers, or other numbers associated with customers, suppliers, or sites.

Fig. 5.19
Controlled Customer Maintenance (1.22.16.4)

Enter the country code, authority, and address or leave country code blank if this record applies to all countries. Only active country codes can be associated with controlled customers and sites. Then specify the control number associated with the address. In Figure 5.19, the control number could be the customer's export license number.

Entering Control Numbers for Items

Use Controlled Item Maintenance (1.22.16.10) to associate control numbers with items.

This programs can be used to store many types of codes, such as codes associating DEA registration numbers with items, foreign tax identification numbers, or other codes associated with items.

Final Consignee. A distribution point that is the final destination.

Enter an item number if this license is for one item. Specify maximum per shipment values, annual shipment values, and currency for this item.

Address Data

This chapter covers the following topics:

***Introduction to Addresses* 170**

Introduces Address Data concepts and features.

***Setting Up Company Addresses* 172**

Explains how to set up company addresses.

***Setting Up Salesperson Addresses* 173**

Describes how to set up salesperson addresses.

***Setting Up Customer Data* 174**

Discusses how to set up customer data.

***Setting Up Supplier Data* 179**

Outlines how to set up supplier data.

***Setting Up Country Code Data* 181**

Outlines how to set up country code data.

***Setting Up Delivery Transit Times* 182**

Discusses how to set up delivery transit times.

***Setting Up Carriers* 183**

Details how to set up carriers.

***Setting Up Delivery Docks* 184**

Explains how to set up delivery docks.

***Setting Up Trailer Codes* 184**

Explains how to set up trailer codes.

***Setting Up Freight Charges* 185**

Details how to set up freight charges.

***Blocking Customer/Supplier Transactions* 189**

Explains how to block customer/supplier transactions.

Introduction to Addresses

The system maintains address records for your organization, customers, suppliers, salespersons, carriers, docks, end users, employees, engineers, and so on. Most address-related information is maintained in business relations; some is maintained in operational address records.

Records, called business relations, are used to manage basic address information. Business relations contain location, contact, and some tax information for all addresses defined in the system. They are created as part of corporate setup using functions found on the Address Setup Menu (36.1.4). These functions are described in *User Guide: QAD Financials*.

Operational address records carry the address information required for operational transactions, such as the details of sales and purchasing operations—for example, the inventory site where items are ordered, the carrier used, and defaults for Enterprise Materials Transfer (EMT).

Operational address records are created in programs such as Carrier Maintenance, Customer Data Maintenance, and Salesperson Maintenance. Customers and suppliers are not available to operational functions until operational address records are created for them.

Having business relation addresses and operational address records set up in different functions supports the segregation of duties by roles. Users responsible for one type of address information are unlikely to be responsible for the other. System administrators can set up notification systems based on a group of predefined roles. Once set up, the members of various roles are automatically notified by e-mail when a new customer or supplier is created so that the required operational address records can be created.

Addresses Menu

Table 6.1 lists programs in the Addresses menu and shows where address records are used.

Table 6.1
Addresses Menu (2)

Menu	Name	Where Used
2.1	Customers Menu	Sales Orders/Invoices, Customer Schedules, Project Realization Management, and Service/Support Management modules
2.3	Suppliers Menu	Purchasing, Supplier Schedules, and Service/Support Management modules
2.5	Salespersons Menu	Sales Orders/Invoices, Project Realization Management, and Service/Support Management modules
2.9	Operational Address List Type Maintenance	Customers, Suppliers
2.10	Op Address List Type Browse	.
2.12	Company Address Maintenance	Bill-to/ship-to addresses in Purchasing. Ship-to address in Accounts Payable. Printed on outgoing documents such as sales orders, invoices, service contracts, statements, and draft payments. Addresses for entities. Addresses for sites required for Global Tax Management (GTM) and Enterprise Material Transfer (EMT). Addresses for Declarants in Site Maintenance.

Menu	Name	Where Used
2.14	Country Code Menu	Taxes, Intrastat, address maintenance, delivery times, user maintenance.
2.15	Logistics Accounting Menu	Used in logistics accounting functions.
2.16	Delivery Transit Time Menu	Order-entry functions.
2.17	Carriers Menu	Shipping functions.
2.18	Shipping Group/Document Menu	Shipping functions. For information on shipping groups, see <i>User Guide: QAD Sales</i> .
2.19	Trailer Codes Menu	Transactions for sales, purchasing, Service/Support Management.
2.20	Freight Charges Menu	Transactions for sales, purchasing, service/support.
2.23	Blocked Transaction Menu	Customer and supplier transactions for sales, purchasing, and service/support.

Address List Types

Business relation addresses and operational addresses have address types.

There are six system-defined business relation address types: dock, enduser, headoffice, reminder, remittance, and ship-to. Some address types, such as reminder and remittance, are used only in financial functions; others, such as ship-to, dock, and enduser, are used only in operational functions. The headoffice type is used in both financial and operational functions. User-defined types are available only in financial functions.

There are nine system-defined operational address list types: carrier, company, customer, ship-to, slsprsn, supplier, dock, enduser, and engineer. These are referenced in operational functions. Operational address list types are assigned to addresses based on the function that creates the record.

For example, Dock Maintenance creates an operational address record with the dock address list type that is linked to the address in the specified business relation with the dock address type. If the business relation does not have an address of the appropriate type for the function, the operational address record cannot be created. The functions, address types, and address list types are shown in Table 6.2.

Table 6.2
Address Types

Operational Address Function	Business Relation Address Type	Operational Address List Type
Carrier Maintenance	Headoffice	Carrier
Company Address Maintenance	Headoffice	Company
Customer Data Maintenance	Headoffice	Customer
Customer Data Maintenance	Ship-to	Ship-to
Salesperson Maintenance	Headoffice	Slsprsn
Supplier Data Maintenance	Headoffice	Supplier
Dock Maintenance	Dock	Dock

Operational Address Function	Business Relation Address Type	Operational Address List Type
End User Data Maintenance	Enduser	Enduser
Engineer Maintenance	Headoffice	Engineer

To group addresses in other ways, you can manually assign additional list type codes to operational addresses. Use Operational Address List Type Maintenance (2.9) to create your own address groups.

List types determine which addresses are included in lookup browses and reports. For example, when presenting lookup information in the Customer field of Sales Order Maintenance (7.1.1), the system includes only addresses with the customer address list type.

Setting Up Company Addresses

Use Company Address Maintenance (2.12) to set up operational address records for your organization's sites and locations. The address record is linked to the headoffice type address in the specified business relation; the operational address record has the company address list type.

These addresses are used in the following ways:

- Addresses for sites are used for tax calculation.
- If you provide Intrastat reports, a company address is associated with each declarant in Declarant Maintenance (29.22.1.20) that submits reports. See *User Guide: QAD Intrastat* for details on Intrastat.
- Addresses for locations may be required for formal shipping documents accompanying movement of goods between locations within a site. See page 50.
- Company bill-to and ship-to addresses are used in purchasing functions, printed on formal documents, and used in tax calculations.
- Your company address is printed on contracts, orders, and invoices in sales and SSM functions.

Fig. 6.1
Company Address Maintenance (2.12)

The screenshot shows a software window titled "Company Address Maintenance" with a menu bar containing "Go To" and "ACTIONS". The main area contains a form with the following data:

- Address: 10000000
- Business Relation: 10000000-st92bmfg
- Name: Quality Products, Inc.
- Address: Manufacturing Division
- Address: One World Way
- Address: implementation>>
- City: Morristown
- State: NJ
- Post: 07960
- Format: 0
- Country: X United States
- USA
- County:
- Attention:
- Telephone:
- Fax/Telex:

Addresses for Purchase Orders

Use Company Address Maintenance to enter your company bill-to and ship-to addresses for purchasing. When the site code on a purchase order line corresponds to a company address code, that company address is used as a ship-to address when printing purchase orders. When using consolidated order processing, this allows a single purchase order to be printed for multiple ship-to addresses.

Addresses and GTM

Global Tax Management calculates taxes based on the address associated with each site. Set up each site with a address record by specifying the site code in the Address field and then linking an business relation for address information. The site will use the headoffice type address from the business relation. On taxable transactions, the system uses the site address to select the correct line-item tax environment.

Deleting Company Addresses

The system verifies the following before you can delete a company address record:

- No open purchase orders reference the address.
- A site with a matching ID does not exist. Deleting such an address would cause problems with programs that expect an address to be associated with a site, such as GTM and Intrastat programs.

Setting Up Salesperson Addresses

Use Salesperson Maintenance (2.5.1) to set up salesperson records. Associate the salesperson record with a business relation for address details. The salesperson record is linked to the headoffice type address in the business relation; the operational address record has the slsprsn address list type.

For each salesperson, specify a default commission percentage and a user-defined territory code. Enter detailed commission percentages for product lines and/or customers. Commission reports calculate amounts from net sales prices or gross margins (net price less standard cost) on posted invoices. Commissions are not reported from debit/credit memos.

Note Use Sales Analysis functions to establish monthly quotas and generate quota reports. See *User Guide: QAD Sales*.

Fig. 6.2
Salesperson Maintenance (2.5.1)

Salesperson Maintenance Go To ACTIONS

Salesperson Address

Salespsn: 5701 Business Relation: 3000-st92bmfg

Name: Acme Supply Co.
Sort Name: Acme Supply Co.
Address: 1 Claridge Drive
Address:
City: Verona State: Post: Format: 0
Country: USA County:
Attention: Attn:
Telephone: Telephone:
Fax/Telex: Fax/Telex:
Added: 04/13/2007

Salesperson Data

Sort Name: Acme Supply Co.
Territory: West
Commission: 2.50%

Set up salesperson before setting up customer records. Up to four default salesperson codes and commission percentages can be associated with each customer. These associations are used as defaults in Sales Quotations, Sales Orders/Invoices, Service/Support Management, and Accounts Receivable.

Use Salesperson Payments Report (2.5.16) to review paid invoices and unapplied payments, sorted by salesperson.

Setting Up Customer Data

Use Customer Data Maintenance (2.1.1) to define or modify customer information that is used in operational activities and create an operational address record. Customer records are initially created in Customer Create (27.20.1.1) and associated with the headoffice address of a business relation. Customer Data Maintenance completes the customer definition by creating an operational address record with a list type of customer.

You can also add operational data for ship-to records created in Customer Ship-To Create (27.20.2.1) and linked to a ship-to address of a business relation. These have an operational address type of ship-to.

To complete the setup for a customer so that it is ready for use in transaction processing, click Next through every frame of this program, adding operational data as needed. Only active customers that have complete operational data are available for transactions.

Fig. 6.3
Customer Data Maintenance (2.1.1)

Customer. Specify a customer to modify with sales and operational data. The address information of the business relation associated with the customer displays. You cannot modify it here.

Salesperson. Enter the salesperson who normally receives commission and quota credit for sales to this customer.

Multiple. Enter Yes to specify up to four salesperson codes.

Ship Via. Enter a code identifying the carrier normally used for shipments to this customer. Ship Via is validated against predefined values entered in Generalized Codes Maintenance for field cm_shipvia, if any. It prints on formal documents such as sales quotes, sales orders, packing lists, and invoices.

Resale. Enter the resale identification code assigned to this customer by the government. Enter resale identification codes for all non-taxable customers.

Region. Enter the region to be used for sales analysis reporting.

Site. This is the default ship-from site for this customer. Typically, enter the site closest to the customer.

In the second Customer Data frame, set up additional data for each customer. The system uses this information during order entry.

Fig. 6.4
Customer Data Frame

Partial OK. The value of Partial OK determines how the system typically processes partial shipments to this customer.

No: The customer does not accept partial shipment. Sales Order Packing List verifies that all line items are allocated and can be completely shipped. If they are not, a packing list does not print for this order.

Yes: A packing list prints and shipments are made when the entire order quantity is not available. The remainder of the order stays in the system as backordered until it can be shipped.

Note The Partial OK setting is effective only if you use packing lists to control shipping. While it prevents the packing list from printing, it does not prevent you from shipping.

Discount Table. Enter a default discount table for use with scheduled orders for this customer. This discount table must be created using the functions on the Cust Sched/RMA Rcpt Pricing Menu (1.10.3). See Chapter 3, “Pricing,” for more details.

Note Most sales activities use the price lists and analysis codes defined with the SO/SQ/RMA Pricing Menu. Supplier activities use the price lists defined with the Supplier Pricing Menu. If this customer does not use scheduled orders, this field has no effect on pricing.

Fixed Price. Enter Yes to indicate that prices negotiated with the customer are fixed. Enter No to indicate that prices negotiated with the customer are not fixed. Prices not fixed are subject to batch updates based on changes in price lists.

Daybook Set. Specify the daybook set typically associated with this customer. This is a required field.

Valid daybook sets are defined in either Daybook Set Maintenance (25.8.7) or Daybook Set by Site Maintenance (25.8.10). The default value and validation for this field depend on the setting of Use Daybook Set by Site in Sales Order Accounting Control (36.9.6):

- When Daybook Set by Site is enabled, the system searches for a daybook set that matches the customer default site and sets the customer record to that value. Otherwise, it uses the first daybook set with a blank site. If you change the default, the specified daybook set must be defined in Daybook Set by Site Maintenance either for the customer site or with a blank site value.
- When you are not using daybook sets by site, the control program value is used as the default in new customer records. If you change the default, the system validates the specified daybook set against records defined in Daybook Set Maintenance.

This field defaults to the following programs for records related to this customer:

- Sales Order Maintenance
- Pending Invoice Maintenance
- Sales Order Shipments
- Call Activity Recording
- Call Invoice Recording
- RMA Maintenance
- RMA Receipts
- RMA Shipments

You can update the default in those programs.

Daybook sets are used to group individual daybooks used during the order cycle. For example, the invoice post and print process uses the customer invoice daybook specified in the associated daybook set to generate an invoice number.

See *User Guide: QAD Financials* for details about daybooks.

Class. Enter the class code that indicates the customer priority. When you cannot fill all orders, items can be allocated by customer class.

SIC. Enter the standard industrial classification (SIC) code associated with this customer. These codes are widely accepted classifications for categorizing companies into industry groupings.

This reference-only field displays on selected reports and inquiries.

Invoice by Authorization. This read-only field is set in the Customer Create function; it indicates how invoice totals should be calculated and displayed for this customer.

No: Invoice totals are calculated by line. This is the typical method for calculating totals, unless the customer is using AR Self-Billing.

Yes: Invoice totals are calculated by authorization number. The printed invoice includes the price and amount for each authorization line as well as the total for all authorization lines. The extended price for each invoice line item is not displayed.

RSS Calendar Option. Specify which calendar to use when the system generates required ship schedule (RSS) for customer scheduled orders. This field defaults from Container/Shipper Control (7.9.24). See *User Guide: QAD Scheduled Order Management* for information on schedule processing.

1 (the default): Use both the customer and shop (manufacturing) calendars to create the RSS. The system searches for calendars in this order:

- Ship-to-specific calendar
- Customer-specific calendar (if the ship-to is different from the customer ID)
- Default customer calendar
- Site-specific shop calendar
- Default shop calendar

2: Use only the customer calendar to create the RSS. The system uses the first three elements from the above list to search for customer calendars. The system makes no calendar adjustments if it cannot find a customer calendar of any type.

3: Use neither the customer calendar nor shop calendar. The system creates schedule dates without any calendar adjustments.

Customer Credit Data

Most customer credit information is defined when the customer is created in AR. A few settings defined here are used during order entry.

Fig. 6.5
Customer Credit Data Frame

Customer Credit Data		
Disc Pct: <input type="text" value="0.00%"/>	Terms: BASE	Last Sale:
PO Required: <input type="checkbox"/>	Bill To:	

Disc Pct. Enter a discount value if the customer normally receives a total order discount in addition to pricing discounts. If the customer qualifies for a volume discount higher than this, the system uses the volume discount.

PO Required. This field determines how the system validates the purchase order field on sales-related documents.

No: No purchase order input is required.

Yes: You can create a sales quote for the customer, although a warning message displays. An actual order cannot be created, however, until a purchase order number is specified.

Customer Freight Data

Set up freight information for each customer. The system uses this information during order entry.

Fig. 6.6

Customer Freight Data Frame

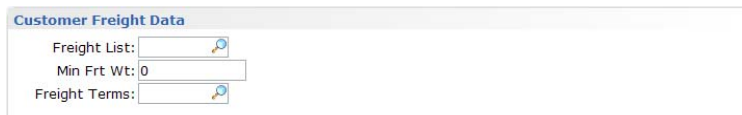

The screenshot shows a software interface titled "Customer Freight Data". It contains three input fields: "Freight List:" with a search icon, "Min Frt Wt:" with the value "0", and "Freight Terms:" with a search icon.

Freight List. Enter a freight list code identifying a set of shipping rates normally used for this customer. This list defaults to the order header for new orders for this customer. See “Setting Up Freight Charges” on page 185 for details.

Min Frt Wt. Enter the minimum weight to use with bulk freight lists for this customer. Shipments that weigh less than this amount are charged based on minimum weight, not the actual shipment weight.

Freight Terms. Enter a code identifying how freight charges are typically calculated for this customer.

Other Customer Data

Other Customer Data Maintenance frames:

- The Address Tax Data frame displays Global Tax Management details specified when the customer was created; they cannot be modified here. See *User Guide: QAD Global Tax Management*.
- The Enterprise Material Transfer Data frame is described in *User Guide: QAD Sales*.
- The Self Billing data frame displays options for configuring self-billing for this customer. These fields are described in *User Guide: QAD Financials*.

Creating Reserved Locations

Use the functions on the Reserved Locations Menu (2.1.9) to associate any number of reserved locations with a customer address. One of these locations can be designated as the customer’s primary location.

You can also create this association directly in Location Maintenance (1.1.18). See “Reserved Locations” on page 48 for details.

These locations reserve inventory to one or more specific customers to ensure adequate supply for sales orders.

Fig. 6.7
Reserved Location Maintenance (2.1.9.1)

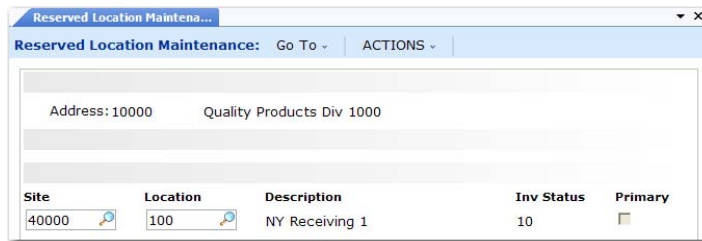

When you create a sales order for a customer with a reserved location, the reserved location defaults during line-item entry. For other customers, the system automatically blocks sales order line-item entry or shipment from a reserved location.

The location you specify must be set up with an inventory status that prevents items from being allocated or considered by planning functions.

You can use the report and inquiry on this menu to view the inventory in reserved locations associated with various customer addresses and drill down to associated sales order detail:

- Detail Allocation Inventory Inquiry (2.1.9.5)
- Detail Allocation Inventory Report (2.1.9.6)

Setting Up Supplier Data

Use Supplier Data Maintenance (2.3.1) to define or modify information for a supplier to be used in operational activities such as purchasing transactions. Suppliers are initially defined in Supplier Create (28.20.1.1.) and associated with the headoffice address of a business relation. Supplier Data Maintenance completes the supplier definition by creating an operational address record with a list type of supplier.

To complete the setup for a supplier so that it is ready for transaction processing, click Next through every frame of this program, adding operational data as needed. Only active suppliers that have complete operational data are available for transactions.

Fig. 6.8
Supplier Data Maintenance (2.3.1)

The screenshot shows the 'Supplier Data Maintenance' window. The 'Supplier Address' section includes fields for Supplier (ICSUP01), Name (IC Supplier 1), Address (IC Supplier 1 Address1), City (Sydney), State, Post, County (AUS), Attention ([2]), Telephone ([2]), Fax ([2]), and Business Relation (ICSUP01). The 'Supplier Data' section includes Sort Name (ICSUP01), Currency (AUD), Supplier, Ship Via (dropdown), Remarks, Carrier, Purchase Contact, Daybook Set (APDB), Site, Kanban Supplier, and Promotion Group.

Setting Up Supplier Accounts

Use Supplier Accounts Maintenance (2.3.7) to set up accounts—PO Receipts, Expensed Item Receipts—required in multinational environments to distinguish between PO receipts received from regular suppliers and those received from any intercompany suppliers. These accounts must be valid, active supplier accounts of type PO Receipts.

Fig. 6.9
Supplier Accounts Maintenance (2.3.7)

The screenshot shows the 'Supplier Accounts Maintenance' window. The 'Supplier' section includes Supplier (3000), Name (Acme Supply Co.), and Active (checked). The 'Accounts' section includes PO Receipts Acct: and Expensed Item Receipts: fields, each with three input boxes and search icons.

These accounts have no default values. If you specify a value, the system always uses it in preference to any other function that generates the related GL transaction.

If you leave the supplier account fields blank, the standard logic for determining account values is used. For inventory items, the system searches for a PO Receipts account, sub-account, and cost center in this order:

- A value defined for the item product line, site, and supplier type in Purchasing Account Maintenance (1.2.5)
- A value defined for the item product line in Product Line Maintenance (1.2.1)
- A value defined for the domain in Domain/Account Control (36.9.24)

For non-inventory items, the system uses the Expensed Item Receipts account from Domain/Account Control.

Setting Up Country Code Data

Records for tax zones, addresses, delivery transit time codes, and users reference alphanumeric country codes defined using the Country Code functions (36.1.3.1.1) on the Corporate Structure Setup Menu; this is the only place where the codes can be created or deleted.

Set up additional operational data in Country Code Data Maintenance (2.14.1). To verify data setup, use Country Code Browse (2.14.2) and Report (2.14.3).

Fig. 6.10
Country Code Data Maintenance (2.14.1)

The screenshot shows a window titled "Country Code Data Maintenance" with a menu bar containing "Go To" and "ACTIONS". The main area contains the following fields:

- Country Code: BE
- Name: Belgium
- Active:
- Alternate Code: BE
- EU Member:
- NAFTA Country:
- DEA Country:
- GATT Country:
- Country Group:
- Country Type:
- Comments:

Country Code. Select a previously defined country code to update. The country name, active status, and EU Member field display data defined for the country. The name displays on printed addresses.

Active. This read-only field indicates whether the country code is active.

Alternate Code. Optionally, enter an alternate code for:

- Sorting in Country Code Browse
- The International Organization for Standards (ISO) country code

Important If the country will be associated with users, you must specify the ISO code here.

Each user must be associated with a country code in User Maintenance (36.3.1). That country code maps to the alternate code you enter here. If you do not have an alternate country code specified here, the system displays an error message in User Maintenance (36.3.1).

ISO country codes must be defined in Generalized Codes Maintenance. If you enter an alternate code that is used for another country, the system displays a warning message.

The ISO country code helps determine the locale for the user. The system uses the ISO code to set up date and number formats and other interface elements for each user session.

See *User Guide: QAD Security and Controls*.

EU Member. This read-only field indicates whether the country is identified as a member country of the European Union (EU) when the code is defined in Country Create. This information determines whether an inventory transaction relates to an intra-EU inventory movement that should be included in Intrastat reporting. This field is not used for GTM.

Comments. Enter Yes to display a screen for recording special requirements, restrictions, or other GTM specifications.

The following fields are only available when Compliance Active is Yes in Regulatory Attributes Control (1.22.24). See “Managing Controlled Substances” on page 162.

NAFTA Country. Reference only. Identifies member countries of the North American Free Trade Agreement.

DEA Country. Reference only. Identifies countries under the jurisdiction of the United States Drug Enforcement Administration.

GATT Country. Reference only. Identifies countries as members of the General Agreement on Tariffs and Trade.

Country Group. Use this field to categorize countries. Use letter codes such as those assigned by current Export Administration Regulations.

Country Type. Reference only. Use this field to categorize countries. Use letter codes such as those assigned by current Export Administration Regulations.

Setting Up Delivery Transit Times

Use Delivery Transit Time Maintenance (2.16.1) to enter standard transit time data for inventory deliveries between a site and the specified country, state, and city. You can specify whether the transit time applies to shipments from the site to an address, from an address to the site, or is the same in both directions. For example, it may take longer to transport goods from a supplier address to your site because items may have to clear customs on the way. The system uses delivery transit times in some automatic date calculations.

For example, when Calculate Promise Date is Yes in Sales Order Control (7.1.24), the system checks the ship-from site and the delivery destination to determine the transit time. It uses the specified number of days along with date information on the order to calculate promise dates or due dates.

See *User Guide: QAD Sales* for information on date calculations.

Fig. 6.11
Delivery Transit Time Maintenance (2.16.1)

The screenshot shows a software window titled "Delivery Transit Time Maint". The window has a menu bar with "Go To" and "ACTIONS". The main content area displays the following information:

- Site: 10000
- Country: US USA
- State: NJ
- City: (blank)
- Usage: All All
- Transit Days: 5

Site. Enter the code representing a site from which inventory is shipped or to which inventory is delivered. This field cannot be blank and the site must already be defined in Site Maintenance (1.1.13).

Country. Enter the code representing the country from which inventory is shipped or to which inventory is delivered. You can leave this field blank or enter a valid, active code.

State. Enter a valid, active code identifying the state from which inventory is shipped or to which inventory is delivered. You can leave this field blank.

City. Enter the city from which inventory is shipped or to which inventory is to be delivered. You can leave this field blank. Values are not validated.

Usage. Specify the usage for this transit time.

Inbound: Transit Days represents the number of calendar days to transport goods from an address to the specified site.

Outbound: Transit Days represents the number of days to transport goods from the specified site to an address.

All: Transit Days is the same for transportation into and out of the specified site.

Transit Days. Enter the number of calendar days to transfer inventory between the inventory site and the location defined by the specified combination of country, state, and city. The system adds this number to the due date on a sales order to calculate the promise date automatically. You must enter a non-zero, positive integer.

Note By leaving Country, State, and City blank, you can create a generic default transit time that calculates a promise date for any unspecified delivery location.

Setting Up Carriers

Use Carrier Maintenance (2.17.1) to create a carrier address record and associate it with the headoffice of business relation. The business relations provides the carrier address details.

The carrier name and address, telephone and FAX numbers, contact names, and the carrier tax ID are printed on shipping documents. Carriers are identified by an operational address list type of carrier.

A carrier handles the transportation of goods from a shipping site. Typically shipments require a single carrier. However, sometimes a series of carriers is needed. For example, a shipment can be transported by truck to be loaded onto a train, transported by train to be loaded onto a ship, then transported by ship to its final destination.

You can associate one carrier or series of carriers for a kind of inventory movement in a shipping group. A carrier cannot be deleted if it is currently in use by any shipment, shipping group, or tax history record.

Fig. 6.12
Carrier Maintenance (2.17.1)

The screenshot shows the 'Carrier Maintenance' window with the following data:

Carrier: FedEx	Business Relation: FedEx
Name: Federal Express	
Address: 10000 Bloomingdale Dr	
Address:	
City: Seattle	State: WA
Postal: 900015	Format: 0
Country: USA	US
County:	
Attention:	Attn:
Telephone:	Telephone:
Fax/Telex:	Fax/Telex:
Email:	
Email 2:	
Sort Name: FedEx	
Tax ID:	

Setting Up Delivery Docks

Dock Maintenance creates a dock address code and associates it with a customer or ship-to code and the business relation linked to that code. The dock code is linked to the selected dock type address in the business relation; the operational address list type for the record is dock.

Use Dock Maintenance (7.3.6) to create an operational address for alternate ship-to addresses, such as a delivery dock in a building that is near to but separate from the usual ship-to address.

Use Customer Scheduled Order Maintenance (7.3.13) to assign docks as default delivery locations for items. If a dock address is used on a scheduled order, it should be used on the sales order shipper as well.

Setting Up Trailer Codes

In addition to line item charges and tax amounts, orders often have miscellaneous charges, such as freight and service associated with them. Use Trailer Code Maintenance (2.19.13) to set up trailer codes prior to entering sales orders.

Fig. 6.13
Trailer Code Maintenance (2.19.13)

The screenshot shows the 'Trailer Code Maintenance' window with the following data:

Trailer Code: 10
Description: Service
Trailer Acct: 4200
Project:
Taxable: <input type="checkbox"/>
Tax Class:
Discount at Payment: <input type="checkbox"/>

Trailer codes can be marked as taxable and associated with a GL account. The account must be a valid, active account of type Standard. Enter the GTM tax class of this trailer code. Trailer items are not subject to commission.

You can also indicate whether the trailer code should be discounted at time of payment. If Yes, the trailer charge amount is discounted in the same way as the sales and tax amounts.

Once established, the three most frequently used taxable and nontaxable trailer codes can be specified as defaults in Sales Order Accounting Control (36.9.6). These defaults display on the trailer of every order but can be changed manually. Taxable and nontaxable trailer codes for contracts in Service/Support Management can be specified in SSM Accounting Control (36.9.10).

You can also associate a trailer code with freight lists. If you want this trailer code to be used rather than the ones defined in Sales Order Accounting Control, you must set Use SO Freight List Trailer Code to Yes in Sales Order Accounting Control.

See “Trailer Code” on page 186.

Note If you are using the Container and Line Charges module, trailer codes are also used to specify line charges during sales order line-item entry. See *User Guide. QAD Sales*.

Setting Up Freight Charges

Many companies add freight charges to sales orders and RMAs. When the system calculates freight terms, it takes into account the shipper, ship-from site, ship-to address, shipment weight, currency, minimum weight, and other factors. Data affecting freight charges is derived from three sources:

- The order
- Customer information
- Freight information entered in the Freight Charges menu

Note Enabling the optional Logistics Accounting module changes how freight charges are tracked and billed.

Table 6.3 lists the programs in the Freight Charges menu.

Table 6.3
Freight Charges Menu (2.20)

Number	Name	Program
2.20.1	Freight List Maintenance	sofrlmt.p
2.20.2	Freight List Browse	sobr002.p
2.20.4	Freight Zone Maintenance	sofrzmt.p
2.20.5	Freight Zone Browse	sobr006.p
2.20.7	Freight Class Maintenance	sofrclmt.p
2.20.8	Freight Class Browse	sobr001.p
2.20.10	Freight Charges Maintenance	sofrcmt.p
2.20.11	Freight Charges Browse	sobr005.p
2.20.12	Freight Charges Report	sofrcrp.p
2.20.13	Freight Terms Maintenance	softrmt.p
2.20.14	Freight Terms Browse	sobr003.p
2.20.24	Freight Control	sofrctmt.p

Freight terms determine how shipping costs are displayed on the order. A customer's freight costs can appear on the order trailer or be added to each line item unit cost.

Once freight lists and terms are defined, assign default lists and terms to customers in Customer Data Maintenance. Each new sales quote or order created for the customer uses these values. Freight list, zone, and class are used to determine the freight charge for an order. The freight zone is based on the ship-to postal code. Freight class is determined by the item sold.

See *User Guide: QAD Sales* for details on how freight is calculated for a sales order.

Freight List Maintenance

Use Freight List Maintenance (2.20.1) to define charges that apply to sales quotes, orders, and RMAs. Typically, you need at least one freight list for each shipping company you use. More than one freight list may be needed if the shipping company supports different types of transportation. For example, a shipping company may ship by train, by truck, by refrigerated truck, and by regular semi-trailer.

Fig. 6.14
Freight List Maintenance (2.20.1)

The screenshot shows a software window titled "Freight List Maintenance". The window has a menu bar with "Go To" and "ACTIONS". The main content area contains the following fields and values:

- Freight List: Fed-X
- Site: 10000
- Currency: USD
- Description: Federated Express
- Type: Unit (dropdown menu)
- Unit of Measure: LB
- Trailer Code: 21
- Freight Mode: (empty)
- Taxable Freight (checkbox)

Set up freight lists for different currencies if your shipper delivers to other countries. You can also define lists per site if the same shipper transports from more than one warehouse or manufacturing site.

Type. Specify whether freight charges are based on the weight of each unit or on the total weight of the items that use this freight list. Valid entries are:

- **Unit:** Freight charges are calculated for individual units based on each unit's shipping weight.
- **Bulk:** Freight charges are calculated based on the total weight of applicable items. Weight is calculated for each order line as the unit weight multiplied by the line item quantity.

Trailer Code. This value links a freight list with the appropriate GL account to use when charging amounts on the sales quote, sales order, or pending invoice trailer.

Note If the trailer codes you associate with freight lists are not the same as the default trailer codes in Sales Order Accounting Control, you must set Use SO Freight List Trailer Code to Yes in Sales Order Accounting Control. Otherwise, errors display and freight is not calculated in order maintenance programs.

Freight Mode. An optional code that can be used to describe the transportation method. Define values in Generalized Codes Maintenance for field fr_mode.

Freight Zone Maintenance

The distance an item is shipped can be an important factor in determining an order's freight charges. Use Freight Zone Maintenance (2.20.4) to set up geographical areas related to freight lists. Relate zones to sites by specifying values in the Site field.

Fig. 6.15
Freight Zone Maintenance (2.20.4)

Freight List: Fed-X
 Site: 10000
 Zone: 1
 Post Start:
 Post End:
 Start:
 End Date:

Zones are bounded by a beginning and ending range of postal codes. Assign a starting and ending effective date, as needed.

Freight Zone Maintenance only sets up zones. Use Freight Charges Maintenance (2.20.10) to determine charges.

Freight Class Maintenance

Use Freight Class Maintenance (2.20.7) to set up classes used in calculating the freight charges defined in Freight Charges Maintenance. Freight class distinguishes different types of shipments requiring different charges. For example, a fragile class is charged at a higher rate because it requires extra handling.

Fig. 6.16
Freight Class Maintenance (2.20.7)

Freight Class: Bulk
 Description: Bulk Freight

Associate freight classes with items in Item Master Maintenance (1.4.1).

Freight Charges Maintenance

Use Freight Charges Maintenance (2.20.10) to relate a freight list, class, and zone, and to specify how charges are calculated. Use start and end dates to phase in new charges if fees rise or fall after a certain date.

Fig. 6.17
Freight Charges Maintenance (2.20.10)

Maximum and Minimum Weight. Enter the highest and lowest weight that can be used with a freight charge. Set up weight boundaries to include all potential shipping weights.

Normally, the freight charges apply to the boundary weight. However, in two cases, this is not true.

- If you enter a minimum weight of 0 (zero), the freight calculation excludes the minimum boundary weight. Freight is never calculated if the actual shipping weight is 0.
- If you set up overlapping ranges so that the maximum of one range is the same as the minimum of the next range, the higher range takes priority. For example, if 1-5 pounds is charged \$10 and 5-10 pounds is charged \$15, \$15 is applied to a weight of 5.

Freight Charge. Indicates a flat rate per shipment. The amount to be charged per order or per item as determined by the Type field in Freight List Maintenance.

Freight Charges Per UM Over Min. Indicates a surcharge over minimum. The freight charge per unit of measure over the minimum listed for this freight list in the Minimum Weight field. This is calculated per order or per item, based on the Type field in Freight List Maintenance.

Freight Charge Per Fr List UM. Indicates a weight-based fee. The freight charge for the unit of measure specified for the freight list in Freight List Maintenance.

Use any combination of these three types when defining freight charges. You can charge a flat rate plus a rate based on weight. Or you can charge a weight-based rate but with an additional charge for amounts over a certain minimum.

Freight Terms Maintenance

Freight Terms Maintenance is not directly related to the other freight maintenance functions. Terms are not related to a specific freight list or charge. Instead, they are specified for a particular customer in Customer Data Maintenance (2.1.1), or for a particular sales order, quote, or invoice.

Freight terms determine:

- Whether to apply freight charges to a particular order, or specify them in general for a particular customer.
- How freight charges are calculated. Table 6.4 lists the six methods for calculating freight charges.
- Whether freight amounts update the Sales Freight Accrued and Sales Freight Applied accounts specified in Domain/Account Control (36.9.24).

Note If you are using Logistics Accounting, freight terms also determine the default logistics charge code and whether accrual is by shipment or line. An additional frame displays in Freight Terms Maintenance for this information.

Table 6.4
Freight Term Types

Type	Description
Add	Freight is calculated, accrued, and placed on the trailer.
Allow	Freight is calculated, accrued, and shown as a negative amount on the trailer.
Collect	Freight is calculated and placed on the trailer. However, the freight charges are not tracked through the Sales Freight Accrued and the Sales Freight Applied accounts. The customer will pay freight charges directly to the freight carrier when the shipment is delivered.
Include	Freight is calculated, accrued, and added to the item's unit price (after you exit the order line item screen).
Prepaid	Freight is calculated and tracked through the Sales Freight Accrued and Sales Freight Applied accounts, but not included on the order or customer invoice because it has been prepaid or is already a part of the normal selling price.
Will Call	Freight is not calculated or accrued—the customer is responsible for the shipping arrangements.

By defining freight terms, you can assign your own codes and descriptions to these six types.

Blocking Customer/Supplier Transactions

You may want to restrict which activity can be initiated in the system for active customers. For example:

- You may want to create sales orders for some customers but not calls or contracts in the Service/Support Management (SSM) module.
- You may need to block a customer that has credit problems.
- You may need to block a supplier who is delivering late or has quality problems.

Note When customers or suppliers are marked as inactive, all related transactions are automatically marked as blocked; you do not need to set up the transactions. Marking a customer or supplier as inactive is done in the AR or AP modules. See *User Guide: QAD Financials*.

Use the functions on the Blocked Transactions Menu (2.23) to block transactions for active customers and suppliers. You start by creating blocked codes that represent the sets of transactions you want to restrict.

The system transactions that can be restricted are predefined and are identified by codes set up in Language Detail Maintenance (36.4.2). Programs associated with standard sales orders and purchase orders can be blocked, as well as customer-related and supplier-related transactions in SSM.

Some restricted transactions are print programs. These programs do not include any information for blocked customers and suppliers in the print output.

The blocked codes group transactions in the ways that meet your business requirements. For example, you can create one code that includes all transactions for the most secure restriction level. You can create other codes that include only customer transactions, only supplier transactions, only SSM transactions, or only order creation transactions.

You then associate the appropriate code with customers and suppliers. The various programs that create blocked transactions check the code to validate that the transaction is allowed for the associated customer or supplier. This ensures that when customers and suppliers have been restricted, appropriate reviews and checks are completed before further activity can be created in the system referencing them.

Table 6.5 lists functions on the Blocked Transactions Menu (2.23).

Table 6.5
Blocked Transactions Menu (2.23)

Menu Number	Menu Name	Description
2.23.1	Blocked Transaction Maintenance	Create, update, and delete blocked codes and assign programs to existing blocked codes.
2.23.2	Blocked Transaction Report	Display blocked codes and their descriptions as set up in Blocked Transaction Maintenance.
2.23.4	Blocked Customer Maintenance	Assign a blocked code to a customer and update or delete the assignment.
2.23.5	Blocked Customer Report	Display blocked codes and blocked transaction codes for a range of customers as set up in Blocked Customer Maintenance.
2.23.7	Blocked Supplier Maintenance	Assign a blocked code to a supplier and update or delete the assignment.
2.23.8	Blocked Supplier Report	Display blocked codes and blocked transaction codes for a range of suppliers as set up in Blocked Supplier Maintenance.

Blocked Transactions

The system can block new transactions from being created for a customer in the sales order programs listed in Table 6.6.

Note When an EMT sales order is entered, the system also checks that the EMT supplier is not blocked. Similarly, the eCommerce EDI gateways check for blocked transactions during document import and export.

Table 6.6
Blocked Customer Sales Order Programs

Menu Number	Menu Name	Program	Transaction Code
7.1.1	Sales Order Maintenance	sosomt.p	SO001
7.1.3	Sales Order Print	sosorp05.p	SO002
7.3.13	Customer Scheduled Order Maintenance	rcsomt.p	SO003
7.9.1	Picklist/Pre-Shipper–Automatic	sososl.p	SO004
7.9.2	Pre-Shipper/Shipper Workbench	rcshwb.p	SO005
7.9.4	Pre-Shipper/Shipper Print	rcrp13.p	SO006
7.9.5	Pre-Shipper/Shipper Confirm	rcsois.p	SO007
7.9.7	Pre-Shipper/Shipper Auto Confirm	rcauis.p	SO008
7.9.8	Sales Order Shipper Maintenance	rcshmt.p	SO009
7.9.9	Sales Order Shipper Print	rcrp11.p	SO010
7.9.12.2	Master Bill of Lading Maintenance	rcmbmt.p	SO011
7.9.13	Sales Order Packing List	sosopk.p	SO012
7.9.15	Sales Order Shipments	sosois.p	SO013
7.12.1	Sales Quote Maintenance	sqqomt.p	SO015
7.12.3	Sales Quote Print	sqqorp05.p	SO016
7.12.5	Sales Quote Copy from Order	sqqocpy.p	SO017
7.12.6	Sales Quote Copy from Quote	sqqoqo.p	SO018
7.12.10	Sales Quote Release to Order	sqqoso.p	SO019
7.13.1	Pending Invoice Maintenance	soivmt.p	SO014

The system can block new transactions from being created for a supplier in the purchasing programs listed in Table 6.6.

Table 6.7
Blocked Supplier Purchasing Programs

Menu Number	Menu Name	Program	Transaction Code
5.2.3	Requisition Maintenance	rqrqmt.p	PO001
5.2.18	Build PO From Requisition	rqpobld.p	PO002
5.3.1	Blanket Order Maintenance	poblmt.p	PO003
5.3.5	Blanket Order Print	poblrp03.p	PO004
5.3.6	Blanket Order Release to PO	poblrel.p	PO005
5.5.1.13	Supplier Scheduled Order Maintenance	rspomt.p	PO006
5.5.3.8	Schedule Print	rsrp05.p	PO007
5.5.3.9	Schedule Print–Fax Format	rsrp09.p	PO008
5.7	Purchase Order Maintenance	popomt.p	PO009
5.10	Purchase Order Print	poporp03.p	PO010
5.13.1	Purchase Order Receipts	poporc.p	PO011
5.13.7	Purchase Order Returns	porvis.p	PO012
5.13.14	PO Shipper Maintenance	rsshmt.p	PO013

Menu Number	Menu Name	Program	Transaction Code
5.13.16	PO Fiscal Receiving	posmrc.p	PO014
5.13.20	PO Shipper Receipt	rsporc.p	PO015

The system can block new transactions from being created for a customer in the SSM programs listed in Table 6.8.

Table 6.8
Blocked Customer SSM Programs

Menu Number	Menu Name	Program	Transaction Code
11.1.1.1	Call Maintenance	fscamt.p	SSM002
11.1.1.7	Call Quote Maintenance	fscqmt.p	SSM003
11.1.1.11	Call Quote Release to Recording	fscqca.p	SSM004
11.1.1.12	Call Copy Quote	fscqcp.p	SSM005
11.1.1.13	Call Activity Recording	fscarmt.p	SSM006
11.1.1.15	Call Invoice Recording	fscaimt.p	SSM007
11.1.8	Call Generator	fscagen.p	SSM001
11.1.15.1	Service Request Maintenance	fssrmt.p	SSM008
11.5.1.1	Contract Quote Maintenance	fsqomt.p	SSM009
11.5.1.5	Contract Quote Release to Contract	fsqosa01.p	SSM010
11.5.1.6	Contract Quote Copy from Quote	fsqosa02.p	SSM011
11.5.1.7	Contract Quote Copy from Contract	fsqosa04.p	SSM012
11.5.13.1	Contract Maintenance	fssamt.p	SSM013
11.5.13.6	Contract Copy to Contract	fsqosa03.p	SSM014
11.5.13.8	Renew Single Contract	fsqosa05.p	SSM015
11.5.13.10	Renew Process/Report	fssaexp.p	SSM016
11.5.18.13	Billing Release to Invoice	fssais.p	SSM017
11.7.1.1	RMA Maintenance	fsmamt.p	SSM018
11.7.1.5	RMA Release to Work Order	fsmarel.p	SSM019
11.7.1.13	RMA Receipts	fsmais.p	SSM020
11.7.1.16	RMA Shipments	fsmash.p	SSM021
11.11.1	Material Order Maintenance	fseomt.p	SSM025
11.11.6	Material Order Shipments	fseops.p	SSM026
11.11.8	MO Direct/Pending Returns	fseore.p	SSM027

The system can block new transactions from being created for a supplier in the SSM programs listed in Table 6.9.

Table 6.9
Blocked Supplier SSM Programs

Menu Number	Menu Name	Program	Transaction Code
11.7.3.1	RTS Maintenance	fsrtvmt.p	SSM022
11.7.3.13	RTS Receipts	fsrtvrc.p	SSM023
11.7.3.16	RTS Shipments	fsrtvis.p	SSM024

Defining Blocked Codes

Use Blocked Transaction Maintenance (2.23.1) to build one or more sets of blocked transactions and identify each set by a blocked code.

You can add blocked codes or modify them. You can also delete them provided they have not been assigned to a customer or supplier.

Note To delete a blocked code, first position the cursor in the Description field.

Choose transactions to block from the predefined set loaded with the system.

After defining blocked codes, associate them with customers in Blocked Customer Maintenance (2.23.4) and suppliers in Blocked Supplier Maintenance (2.23.7).

When a customer has been assigned a blocked code, all end users of that customer in SSM are automatically blocked from the same transactions.

Fig. 6.18
Blocked Transaction Maintenance (2.23.1)

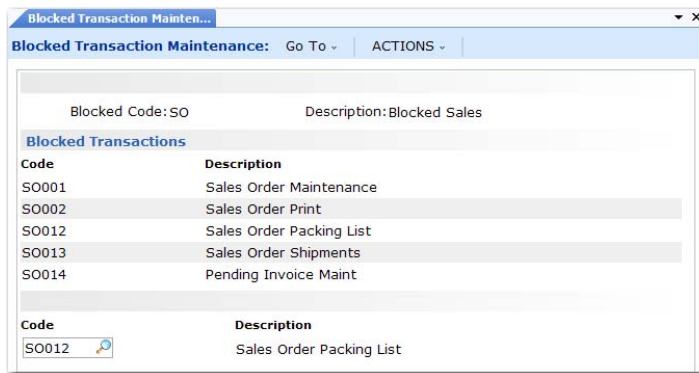

Blocked Code. Specify a code (maximum 8 characters) to identify a set of blocked transactions that can be assigned to a selected customer or supplier.

Description. Enter a brief (24-character maximum) description of the blocked transaction code.

Code. Select the transaction code that identifies a program to be associated with this blocked code from the predefined list. The system displays the program description next to the code.

Blocked Transaction Report (2.23.2) lists the blocked codes defined in Blocked Transaction Maintenance and provides details of the blocked transactions associated with each blocked code. You can display the blocked transactions for a single blocked code or for a range of blocked codes.

See “Blocked Transactions” on page 190.

Updating Customer or Supplier Records

Use Blocked Customer Maintenance (2.23.4) and Blocked Supplier Maintenance (2.23.7) to assign a blocked code to customers and suppliers. Each customer or supplier can be assigned only one blocked code.

Once a customer or supplier is assigned a blocked code, the transactions identified by the code cannot be created for that customer or supplier.

Figure 6.19 illustrates Blocked Customer Maintenance. Blocked Supplier Maintenance is exactly the same.

Fig. 6.19
Blocked Customer Maintenance (2.23.4)

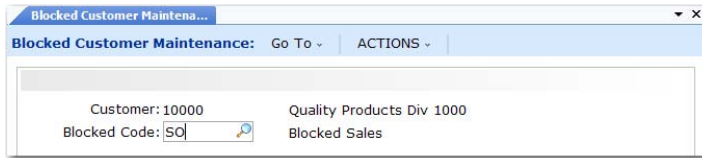

You can remove this restriction by deleting the relevant record from Blocked Customer Maintenance (2.23.4) or Blocked Supplier Maintenance (2.23.7).

Blocked Customer Report (2.23.5) and Blocked Supplier Report (2.23.8) list blocked customers and suppliers and provide details of their blocked transactions. You can display information for a single blocked customer or supplier, or for a range of customers or suppliers.

Example Blocked Transaction

Figure 6.20 illustrates the message that displays when you try to create a sales order for a customer that has an associated blocked code that includes the Sales Order Maintenance transaction.

Fig. 6.20
Sales Order Maintenance (7.1.1)

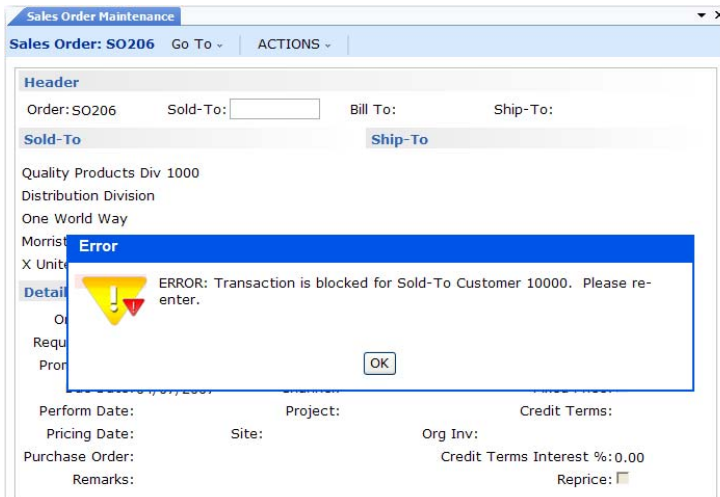

Logistics Accounting

Logistics Accounting lets you define and track individual costs associated with the transportation of goods in and out of company locations.

***Introduction to Logistics Accounting* 196**

Introduces the basics of logistics accounting and costs, including freight charges, insurance, duty, customs clearance, and handling charges.

***Setting Up Logistics Accounting* 202**

Describes how to set up logistics accounting.

***Accruing Inbound Logistics Charges* 212**

Explains how and when inbound logistics charges accrue.

***Accruing Outbound Logistics Charges* 223**

Explains the prerequisites for the accrual process for outbound logistics charges.

***Updating Pending Invoices* 229**

Describes how to use Logistics Charge Pending Invoice Maintenance to update a logistics supplier on an open pending invoice.

***Matching Logistics Charges* 230**

Discusses how to use the Logistic Charge tab of Receiver Matching to match the accruals on pending invoices to the logistics supplier invoice for payment.

***Generating Logistics Reports* 231**

Explains how to generate logistics reports.

Introduction to Logistics Accounting

Logistics costs are the costs incurred when a product is moved from one location to another. These costs can include not only the freight charges paid to carriers, but also insurance, duty, customs clearance, handling charges, and so on. Depending on the freight terms, these costs can be paid by the supplier and recharged to the customer within the item price or as a trailer charge. They can also be paid by the customer directly to the carrier, insurer, customs, and so on.

As manufacturing companies increasingly look for cheaper materials and components from remote sources, logistics costs have become a more significant aspect of cost management. Accurate product and customer profitability information that includes the total cost of purchasing or selling items supports better pricing and financial analysis decisions.

Logistics Charges

The individual costs payable to third-party suppliers for the transportation of goods are referred to as *logistics charges*. Logistics Accounting lets you define logistics charges for any inbound and outbound transportation costs payable to third-party suppliers.

Inbound logistics charges are the transportation costs associated with purchasing items from external suppliers. *Outbound* logistics charges are the transportation costs associated with the shipment of items from a company location to customers or other company locations.

For some companies, a significant proportion of purchases are imports. Logistics costs have a large financial impact since they can represent a high percentage of the total delivered cost and must be included in price comparisons with local sources. In Logistics Accounting, inbound logistics charges are considered part of the overall cost specific to each item and included in the item cost.

For other companies, the shipment of goods by third-party carriers is a frequently occurring expense. Tracking the amounts owed to carriers as a separate liability in the general ledger (GL) provides better control over invoices from suppliers. Identifying variances in expected freight charges and actual invoice amounts reduces the risk of duplicate or over payment of logistics charges. Tracking these charges improves visibility of total outbound freight costs, helping to reduce these costs by reviewing order quantities or seeking alternative carriers.

Logistics Charge Accruals

When items are purchased or shipped, you can accrue logistics charges as part of the process. GL accruals for inbound logistics charges are triggered by purchase receipts. GL accruals for outbound logistics charges are triggered by shipments. For each receipt or shipment, a pending invoice is created for each logistics charge accrual. Inbound logistics charges are built into the GL cost for items.

Note See “Accrual Currency” on page 212 for information on how the system determines the accrual currency used for inbound and outbound logistics charges.

Figure 7.1 summarizes the steps involved in accruing logistics charges.

Fig. 7.1
Logistics Accounting Workflow

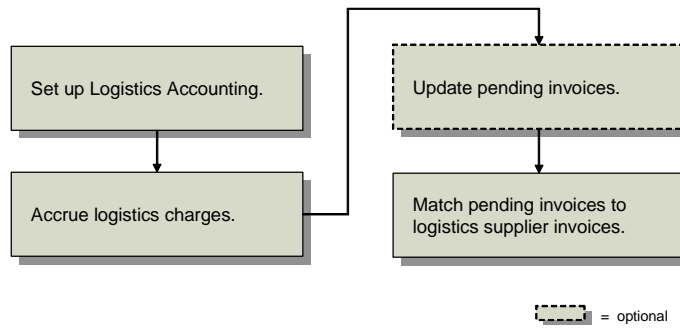

Receiver matching of pending invoices is described in *User Guide: QAD Financials*.

Apportioning Logistics Charges

When an invoice is received from a logistics supplier, the total amount of the invoice is recorded in Supplier Invoice Create (28.1.1.1). To capture the logistics costs for individual line items, a portion of the total invoice amount is allocated to each line item on the associated order.

The system apportions inbound and outbound logistics charges to line items on an order when the pending invoice is created, based on the apportion method associated with the logistics charge code. The total invoice amount is allocated to individual line items as a ratio of the accrued logistics charges.

When recording an invoice for inbound logistics charges, you can automatically update the current costs of PO line items with the allocated amounts. Current costs are updated only when the last cost method is used for the current cost set. If another costing method is used, current costs for purchased items are not updated.

Example Item A and item B are purchased from a single supplier and shipped to a company location. The GL and current costs for these items consist of the unit cost from the item supplier and the cost to ship each item.

Table 7.1
Example Item Costs

	Item A	Item B
Material	10	12
Freight	3	2
Total cost	\$13	\$14

When the order arrives, item A is received in a quantity of 400 and item B in a quantity of 200. Table 7.2 shows the accrued freight charges for each item.

The logistics supplier sends an invoice in the amount of \$2000 for freight. The total accrued freight is \$1600. When the freight invoice is recorded, the system uses the following equation:

$$\text{Apportion Value} = \text{Line Item Accrual} / \text{Total Accrual} * \text{Total Invoice Amount}$$

Table 7.2
Apportioning by Accrued Value

Item	PO Qty	GL Freight	Accrued Freight	Apportion Value
A	400	\$3	\$1200	$1200 / 1600 * 2000 = \$1500$
B	200	\$2	\$400	$400 / 1600 * 2000 = \$500$

The actual freight cost for item A is \$3.75 per unit ($\$1500 / 400$) and \$2.50 for item B ($\$500 / 200$). When the last cost method is used for the current cost set, the system updates the current costs for items A and B with the allocated values.

You specify the apportion method in Logistics Charge Code Maintenance (2.15.1). The default, system-defined apportion method 01 is the only supported apportion method.

Pending Invoices

Pending invoices convey authority to pay the supplier. Pending invoices control who receives payment, how much they receive, and when payment is sent. Invoices are typically recorded in Supplier Invoice Create (28.1.1.1) after an invoice is received from a supplier.

Pending invoices track the estimated amounts owed to suppliers before an invoice is received for the actual amount. Pending invoices for logistics charges are created automatically during purchase receipts and shipments. Logistics charge accruals are also referred to as pending invoices.

During receiver matching, you can match the amounts from pending invoices to actual invoice amounts. The more information provided on the pending invoice, such as the supplier of the logistics charge, the easier it is to match it to an invoice.

When purchased items are shipped from an item supplier, you might not know the name of the logistics supplier until the goods arrive. Logistics charges can accrue without specifying a logistics supplier. After an invoice arrives, you can define the logistics supplier on the pending invoice using Logistics Charge Pending Invoice Maintenance (2.15.7). During receiver matching, it is easier to match invoice amounts to pending invoices when logistics suppliers are assigned.

Note When you ship items to a customer, you must specify the logistics supplier or an error is generated.

Internal and External References

Each pending invoice includes an internal reference and, optionally, an external reference. An *internal reference* is a code identifying a shipment or receipt created by the system, such as a receiver number or shipper ID. An *external reference* is an identifier supplied by a third-party logistics supplier, such as a bill of lading number, carrier tracking number, or packing slip number.

During receiver matching, use internal and external references to help match invoices from logistics suppliers to pending invoices.

Logistics Accounting Programs

Table 7.3 lists the programs used in Logistics Accounting.

Table 7.3
Logistics Accounting Programs

Menu Number	Description	Program Name
2.15	Logistics Accounting Menu...	
2.15.1	Logistics Charge Code Maintenance	lalcmt.p
2.15.2	Logistics Charge Code Inquiry	lalcic.p
2.15.4	Terms of Trade Maintenance	latotmt.p
2.15.5	Terms of Trade Inquiry	latotiq.p
2.15.7	Log Charge Pending Invoice Maintenance	lapvmt.p
2.15.13	Inbound Account Maintenance	laiacmt.p
2.15.14	Inbound Account Inquiry	laiaciq.p
2.15.16	Outbound Accrual Account Maint	laoacrm.p
2.15.17	Outbound Accrual Account Inquiry	laoacri.p
2.15.19	Outbound Expense Account Maint	laoexpm.p
2.15.20	Outbound Expense Account Inquiry	laoexpiq.p
2.15.24	Logistics Accounting Control	lacpm.p
5.13.19	PO Shipper Receipt Into Transit	lagitrc.p
28.21.1	Uninvoiced Logistics Charge Delete/Archive	aplaup.p
28.17.13	Logistics Charge Variance Report	laaprp01.p
28.17.14	Open Logistics Charges Report	laaprp02.p
36.9.1	Logistics Operational Accounting Control	filacpm.p

Modified Programs

When Logistics Accounting is enabled, additional fields and frames display in the programs listed in Table 7.4. The Inbound/Outbound column in the table indicates if the program is used for outbound logistics charges or inbound charges.

Table 7.4
Programs with Additional Fields for Logistics Accounting

Menu Number	Description	Logistics Accounting Fields	Inbound/ Outbound
2.3.1	Supplier Data Maintenance	Terms of Trade, Logistics Supplier	Inbound
2.20.13	Freight Terms Maintenance	Logistics Charge Code	Outbound
5.3.1	Blanket Order Maintenance	Terms of Trade, Transport Days, Logistics Supplier	Inbound
5.5.1.13	Scheduled Order Maintenance	Terms of Trade, Transport Days, Logistics Supplier	Inbound
5.7	Purchase Order Maintenance	Terms of Trade, Transport Days, Logistics Supplier,	Inbound
5.13.14	PO Shipper Maintenance	Carrier Shipment Ref, Logistics Supplier,	Inbound

Menu Number	Description	Logistics Accounting Fields	Inbound/Outbound
5.13.16	PO Fiscal Receiving	Carrier Shipment Ref, Logistics Supplier	Inbound
5.13.18	PO Shipper/Invoice Maint	Logistics Supplier, In Transit Frame	Inbound
7.1.1	Sales Order Maintenance	Logistics Supplier	Outbound
7.9.2	Pre-Shipper/Shipper Workbench	Logistics Supplier	Outbound
7.9.8	Sales Order Shipper Maintenance	Logistics Supplier	Outbound
7.9.15	Sales Order Shipments	Logistics Supplier, Shipment ID	Outbound
7.12.1	Sales Quote Maintenance	Logistics Supplier	Outbound
7.13.1	Pending Invoice Maintenance	Logistics Supplier, Shipment ID	Outbound
11.7.1.1	RMA Maintenance	Logistics Supplier, Shipment ID	Outbound
11.7.1.13	RMA Receipts	Logistics Supplier, Shipment ID	Outbound
11.7.1.16	RMA Shipments	Logistics Supplier, Shipment ID	Outbound
12.17.13	Distribution Order Workbench	Freight Data, Logistics Supplier	Outbound
12.17.14	Distribution Order Maintenance	Freight Data, Logistics Supplier	Outbound
12.17.21	Distribution Order Processing	Freight Data, Logistics Supplier, Shipment ID	Outbound
12.17.22	Distribution Order Shipments	Freight Data, Logistics Supplier, Shipment ID	Outbound

The programs listed in Table 7.5 perform additional processing when Logistics Accounting is used. In most cases, no changes to the user interface are needed; the processing is internal to the program logic. The discrete shipment programs prompt for a shipment ID. These include Sales Order Shipments and distribution order and RMA programs that ship items.

Table 7.5
Programs with Additional Processing for Logistics Accounting

Menu No.	Description	Additional Processing
5.2.18	Build PO from Requisitions	Copies terms of trade from supplier record to new POs; assigns a default value to transport days; copies logistics supplier from Logistics Charge Code Maintenance; calculates tax on logistics charges
5.3.6	Blanket Order Release to PO	Copies terms of trade, transport days, and logistics supplier from blanket orders to released POs; calculates tax on logistics charges
5.13.1	Purchase Order Receipts	Creates pending invoices, accrues logistics charges, and calculates taxes

Menu No.	Description	Additional Processing
5.13.7	Purchase Order Returns	Updates GL logistics charge accounts
5.13.13	PO Container Maintenance	Verifies all referenced PO lines have the same terms of trade as the first PO line added
5.13.20	PO Shipper Receipt	Creates pending invoices, accrues logistics charges, and calculates taxes
5.19	Purchase Order Cost Update	Recalculates costs after terms of trade codes are changed
7.1.1	Sales Order Maintenance (for EMT purchase orders)	Generates EMT POs with logistics data; copies terms of trade from the PO supplier, assigns default transport days, and copies logistics supplier from Logistics Charge Code Maintenance; calculates tax on logistics charges
7.7.1 7.7.5	Container Workbench SO Container Maintenance	Verifies all referenced sales order lines have the same freight terms as first SO line added
7.9.5	Pre-Shipper/Shipper Confirm	Creates pending invoices, accrues logistics charges, and calculates tax
7.9.7	Pre-Shipper/Shipper Auto Confirm	Creates pending invoices, accrues logistics charges, and calculates tax
7.9.15	Sales Order Shipments	Creates pending invoices, accrues logistics charges, and calculates tax
7.9.21	Shipper Unconfirm	Reverses GL transactions created during confirmation
7.12.5 7.12.6 7.12.10	Sales Quote Copy from Order Sales Quote Copy from Quote Sales Quote Release to Order	Copies logistics data from the source document to the target document
11.7.1.1 11.7.1.13 11.7.1.16	RMA Maintenance RMA Receipts RMA Shipment	Creates pending invoices, accrues logistics charges, and calculates tax
12.17.21 12.17.22	Distribution Order Processing Distribution Order Shipments	Creates pending invoices, accrues logistics charges, and calculates tax

Setting Up Logistics Accounting

Figure 7.2 shows steps for setting up Logistics Accounting. Each step is discussed in detail in the following sections.

Fig. 7.2
Setting Up Logistics Accounting

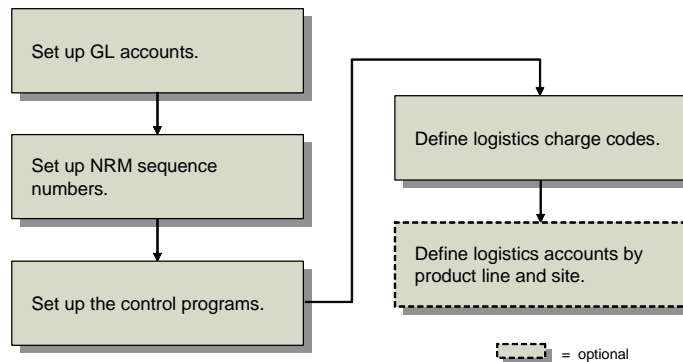

Setting Up GL Accounts

You can define default GL accounts, sub-accounts, and cost centers that are accessed when logistics charges are accrued and invoiced. Separate sets of accounts can be used to track inbound and outbound logistics charges. For outbound logistics charges, you can use separate sets of accounts to track the costs associated with shipments to customers and shipments to other company locations. See *User Guide: QAD Financials* for information on setting up accounts.

Each logistics charge account is identified by an account code, an optional sub-account code, and an optional cost center code. Use GL Account Create (25.3.13.1) to set up GL accounts before defining default logistics accounts in the Logistics Accounting module.

Table 7.6 lists the accounts used by Logistics Accounting. The Type column indicates how the account is used. The Use column indicates the transaction that uses the account.

Table 7.6
Logistics Charge Accounts

	Account	Type	Use
Inbound	Accrual	Liability	PO Receipt, Invoice
	Expense	Expense	PO Return
	Variance	Expense	Invoice
Outbound	Sales Order Accrual	Liability	Shipment, Invoice
	Sales Order Expense	Expense	Shipment
	Sales Order Variance	Expense	Invoice
	Distribution Order Accrual	Liability	Shipment, Invoice
	Distribution Order Expense	Expense	Shipment
	Distribution Order Variance	Expense	Invoice

Note When Logistics Accounting is used, the Sales Freight Applied and Sales Freight Accrued accounts defined in Domain/Account Control (36.1) are not used for logistics charge accrual transactions, unless you specify the same accounts in Outbound Accrual Account Maintenance and Outbound Expense Account Maintenance.

The following illustrations show the functions that create GL transactions for logistics charges and the accounts used. In both examples, an invoice in the amount of \$110 is received from the logistics supplier and applied to the accrued amount.

Figure 7.3 summarizes the GL transactions created and accounts used to track inbound logistics charges. Inbound logistics charge accruals are triggered by purchase receipts.

Fig. 7.3
Inbound GL Transactions

Inbound Logistics Charge Transaction Summary					
PO Receipt			PO Return		
Inventory	Accrual		Expense	Inventory	
100			-100		-100

Invoice			
Accrual	Variance	Accounts Payable	
100	10		110

Figure 7.4 summarizes the GL transactions created and accounts used to track outbound logistics charges.

Fig. 7.4
Outbound GL Transactions

Outbound Logistics Charge Transaction Summary					
Shipment			Return		
Expense	Accrual		Expense	Accrual	
100			-100		-100

Invoice			
Accrual	Variance	Accounts Payable	
100	10		110

Setting Up NRM Sequence Numbers

All pending invoices must have an internal reference number. Before you can accrue outbound logistics charges, you must set up separate Number Range Management (NRM) sequence codes used as identifiers for discrete sales order and distribution order shipments. See *User Guide: QAD System Administration* for details on Number Range Management.

The system uses the sequence codes to determine what format to use when assigning sequential internal reference numbers to discrete shipments in the following programs:

- Sales Order Shipments (7.9.15)
- RMA Maintenance (11.7.1.1)

- RMA Receipts (11.7.1.13)
- RMA Shipments (11.7.1.16)
- Distribution Order Processing (12.17.21)
- Distribution Order Shipments (12.17.22)

Note This step is not required for other types of shipments. For sales order shippers, the shipper number is used as the internal reference. Shipper sequence codes are defined in Container/Shipper Control (7.9.24). When distribution orders use shipper documents, the shipper number is also used. Inbound logistics charge accruals use receiver or PO shipper numbers as internal references.

Use Number Range Maintenance (36.2.21.1) to create sequence parameters for sales order shipments and distribution order shipments. RMAs use sales order sequences. See *User Guide: QAD System Administration* for more information on number ranges.

Fig. 7.5
Number Range Maintenance (36.2.21.1)

Target Dataset. Enter the dataset identifier associated with this sequence:

- Enter la_so_ship_id for sales order shipments.
- Enter la_do_ship_id for distribution order shipments.

Internal. Enter Yes to have NRM generate sequence numbers automatically. Enter No to let users supply numbers that are validated against the NRM sequence.

Setting Up the Control Programs

Logistics Accounting Control

Use Logistics Accounting Control (2.15.24) to:

- Activate the Logistics Accounting module.
- Assign NRM sequence codes to sales order and distribution order shipments.

Fig. 7.6
Logistics Accounting Control (2.15.24)

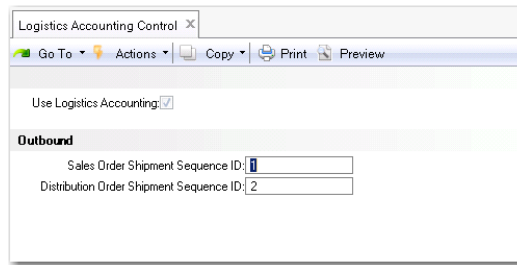

Use Logistics Accounting. Enter Yes to enable the functionality in the Logistics Accounting module. When you enable Logistics Accounting, additional logistics accounting fields are activated in other modules.

Sales Order Shipment Sequence ID. Enter the NRM sequence code used for sales order shipments. The sequence code must have the target dataset la_so_ship_id.

Distribution Order Shipment Sequence ID. Enter the NRM sequence code used for distribution order shipments. The sequence code must have the target dataset la_do_ship_id.

Logistics Operational Accounting Control

Use Logistics Operational Accounting Control (36.9.1) to:

- Specify whether pending invoices must contain a third-party logistics supplier before they can be selected for receiver matching.
- Specify default GL accrual, expense, and variance accounts for tracking inbound and outbound logistics charges. You can define a separate set of default outbound accounts for sales order and distribution order shipments.

If you only want to track inbound logistics charges, you can leave the Outbound fields blank. If you only want to track outbound logistics charges, you must first define inbound accounts when Verify GL Accounts is Yes in Domain/Account Control.

Fig. 7.7
Logistics Operational Accounting Control (36.9.1)

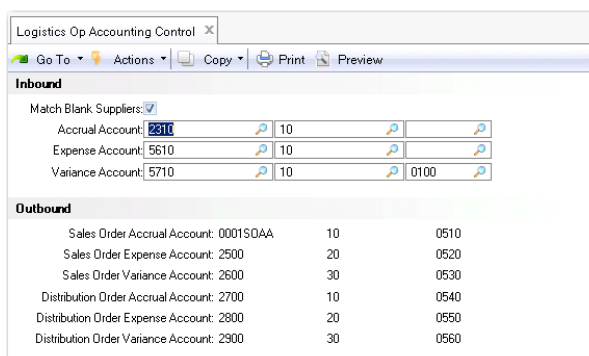

The accounts defined in Logistics Operational Accounting Control are used as the defaults when you create a logistics charge code in Logistics Charge Code Maintenance (2.15.1). Since these are default accounts, none of the static data or transactions that reference them are changed when these accounts are modified in Logistics Operational Accounting Control.

Match Blank Suppliers. When No, only pending invoices with a defined logistics supplier display when logistics charges are selected for matching in the Logistic Charge tab of Receiver Matching Create (28.2.1). The default is No.

When set to Yes, you can indicate during receiver matching whether to display pending invoices with blank suppliers using the Include Blank Suppliers field in the Logistic Charge tab of Receiver Matching Create.

See *User Guide: QAD Financials* for more information on receiver matching.

Accrual Account, Expense Account, Variance Account. Enter the accounts, sub-accounts, and cost centers used to track inbound logistics charge accruals, expenses, and variances.

These accounts provide the defaults in Logistics Charge Code Maintenance (2.15.1).

Sales Order Accrual Account, Expense Account, Variance Account. Enter the accounts, sub-accounts, and cost centers used to track outbound logistics charge accruals, expenses, and variances associated with sales order and RMA shipments.

Distribution Order Accrual Account, Expense Account, Variance Account. Enter the accounts, sub-accounts, and cost centers used to track outbound logistics charge accruals, expenses, and variances associated with distribution order shipments.

The sales order and distribution order accounts provide the defaults in Logistics Charge Code Maintenance (2.15.1).

Defining Logistics Charge Codes

Use Logistics Charge Code Maintenance (2.15.1) to define codes for each logistics charge incurred and payable to a third-party supplier when purchasing or shipping items. These accounts default from Logistics Operational Accounting Control, but you can change them.

A logistics charge code can be used for inbound charges, outbound charges, or both. There is nothing to indicate whether a logistics charge code is used for outbound or inbound purposes. When an inbound and outbound charge is managed differently, define two separate codes.

Inbound Logistics Charges

Inbound logistics charges can include freight, duty, insurance, and so on. You can indicate whether an inbound logistics charge is taxable and assign default tax parameters.

To accrue inbound logistics charges and include them in the cost of purchased items, you must associate a separate cost element with each logistics charge code used for inbound purposes. When modifying the cost element, you may also specify PO price variance account and AP rate variance account information. You cannot assign the same cost element to more than one logistics charge. See “Creating Logistics Cost Elements” on page 213 for details on cost elements.

For example, you create a cost element named Freight and assign it to the Freight logistics charge code. You cannot assign the Freight cost element to any other logistics charge code. If you want to track different types of freight, such as domestic and overseas, you must create a cost element for each logistics charge code.

Outbound Logistics Charges

Outbound logistics charges include the cost of freight only. These are charges paid to third-party carriers when items are shipped to a customer or another company location.

You do not need to define tax parameters since outbound freight charges use the tax parameters from the trailer code associated with the freight charge on the order or shipment. You can track outbound charges for sales orders and distribution orders using separate sets of accounts.

Fig. 7.8
Logistics Charge Code Maintenance (2.15.1)

Logistics Charge Code. Enter an 8-character code identifying a logistics charge. This code can be used for both inbound and outbound logistics charges.

Description. Enter a brief (24 characters) description for this logistics charge.

Taxable. Indicate whether this logistics charge is taxable. This field applies when the charge code is used for inbound purposes. Outbound freight charges use the tax parameters associated with the freight charge on the order or shipment.

Tax Class. Enter the tax class used for an inbound taxable logistics charge.

Close Accruals on First Invoice. Enter the default setting for the Finished field in the pop-up window in the Logistic Charge tab of Receiver Matching Create. You can override the default in the Logistic Charge pop-up window.

No: If you might receive multiple invoices for this charge, set this field to No. For example, a freight charge may include one invoice for overseas shipping and another for transportation from the dock to your warehouse.

Yes: If you typically receive a single invoice for this logistics charge, set this field to Yes.

Logistics Supplier. Optionally enter a default logistics supplier for this logistics charge.

Apportion Method. Specify the apportioning method to use when matching an invoice for this logistics charge. See “Apportioning Logistics Charges” on page 197.

01: Apportion by the accrued value. The total invoice amount is allocated to individual line items as a ratio of the accrued logistics charges.

When an invoice is received from a logistics supplier, the total amount of the invoice is matched. To capture the logistics costs for individual line items, a portion of the total invoice amount is allocated to each line item on the order. To determine the apportion value for each line item, the line item accrual value is divided by the total accrual value for the order, then multiplied by the total invoice amount.

The default, system-defined apportion method is identified with code 01.

Fig. 7.9
Logistics Charge Code Maint, Inbound Frame

Logistics Charge Code: LCC23
Description: Logistics Charge Code 23

Inbound

Cost Element:

Accrual Account:	2310	10	
Expense Account:	5610	10	
Variance Account:	5710	10	0100

Outbound

Sales Order Accrual Account:	0023SOAA	10	0510
Sales Order Expense Account:	0023SOEA	10	0510
Sales Order Variance Account:	0023SOVA	10	0510
Distribution Order Accrual Account:	0001DOAA	20	0610
Distribution Order Expense Account:	0001DOEA	20	0610
Distribution Order Variance Account:	0001DOVA	20	0610

Cost Element. Optionally enter a cost element to associate with this logistics charge. The system uses the values in this cost element when accruing inbound logistics charges for individual items. See “Creating Logistics Cost Elements” on page 213 for details.

Define accrual, expense, and variance accounts for this logistics charge code. These accounts are used as the defaults when you define detailed accounts in Inbound Account Maintenance (2.15.13), Outbound Accrual Account Maintenance (2.15.16), and Outbound Expense Account Maintenance (2.15.19).

Defining Detailed Logistics Accounts

Although inbound and outbound logistics accounts are defined for each logistics charge in Logistics Charge Code Maintenance, you may want to define logistics accounts at a more detailed level.

You can separately track logistics charges by product line at multiple sites within the same entity. For example, you may want to track logistics charges for different product lines at different sites using separate accounts.

Use the following programs to specify GL accrual, expense, and variance accounts used for inbound and outbound logistics charges by product line, site, and supplier or customer type:

- Inbound Account Maintenance (2.15.13)
- Outbound Accrual Account Maint (2.15.16)
- Outbound Expense Account Maint (2.15.19)

All accounts default from the specified logistics charge code, but you can change them.

Fig. 7.10
Inbound Account Maintenance (2.15.13)

Logistics Charge Code. Enter a logistics charge code previously defined in Logistics Charge Code Maintenance.

Product Line. Enter the product line to associate with these accounts.

Site. Optionally enter the site to associate with these accounts. Site security is enforced. When blank, the user must have access to all sites in the system. If you enter a supplier type, you must enter a specific site. See *User Guide: QAD Security and Controls* for details about security.

Supplier Type. Optionally enter a code classifying item suppliers by type. During PO receipts and returns, the system searches for GL accounts using the supplier type of the item supplier, not the logistics supplier.

This field is validated against codes set up in Supplier Type Create.

Fig. 7.11
Outbound Accrual Account Maintenance (2.15.16)

Supplier Type. Optionally enter a code classifying suppliers by type. During shipment processing, the system searches for GL accounts using the supplier type of the logistics supplier. If you enter a supplier type, you must enter a specific site.

This field is validated against codes set up in Supplier Type Create.

Fig. 7.12
Outbound Expense Account Maintenance (2.15.19)

Logistics Charge Code:	LCC23	Logistics Charge Code 23
Product Line:		Blank PL
Site:		
Customer Type:		
Channel:		Default Sales Channel
Sales Order Expense Account:	0023SOEA	10 0510
Sales Order Variance Account:	0023SOVA	10 0510
Distribution Order Expense Account:	0001DOEA	20 0610
Distribution Order Variance Account:	0001DOVA	20 0610

Customer Type. Optionally enter a code classifying customers by type. During shipment processing, the system searches for GL accounts using the type of the order customer.

This field is validated against codes set up in Customer Type Create.

Channel. Optionally enter a code identifying a distribution channel.

This field is validated against codes set up in Generalized Codes Maintenance for field so_channel.

When searching for GL accounts, the system first looks for a match in the detail logistics accounts. If no match is found, the accounts entered in Logistics Charge Code Maint for the logistics charge are used.

When searching for a match in the detail accounts, the system uses the following hierarchy:

- 1 Matching logistics charge code, product line, site, and supplier or customer type
- 2 Matching charge code, product line, and site with a blank supplier or customer type
- 3 Matching charge code and product line

Calculating Taxes for Logistics Charges

The system calculates taxes on logistics charges and creates tax detail records for them, identified with unique tax transaction types.

For inbound charges, the tax status depends on the tax data defined for the charge in Logistics Charge Code Maintenance. Outbound charges use the tax parameters associated with the freight charge on the order or shipment.

For details on calculating taxes with Global Tax Management (GTM), see *User Guide: QAD Global Tax Management*.

The tax point for a logistics charge is based upon the setting of Accrue Tax at Receipt for applicable tax rate in Tax Rate Maintenance (2.13.13.1). The value of this field applies to both inbound and outbound charges.

- For inbound charges, if Accrue Tax at Receipt is Yes, taxes accrue at receipt. When this field is No, taxes accrue at invoicing.
- For outbound charges, if Accrue Tax at Receipt is Yes, taxes accrue at shipment. When this field is No, taxes accrue at invoicing.

Taxes on logistics charges are not displayed to the user and do not print on formal inbound or outbound documents. They can be viewed using Tax Detail by Transaction Inquiry (2.13.15.2) and Report (2.13.15.3). They can, however, be viewed and edited when the invoice is recorded in Supplier Invoice Create.

Inbound Tax Calculations

When determining the tax environment for inbound charges, the system uses the following data:

- The ship-from tax zone of the logistics charge supplier, if available; otherwise, the tax zone of the purchase order line site
- The ship-to tax zone from the purchase order line site
- The tax class of the logistics charge supplier, if available; otherwise, the tax class of the purchase order line site

If the system cannot find a tax environment, the default tax environment from Global Tax Management Control (2.13.24) is used.

When determining the tax rate, the system uses:

- The tax class of the logistics charge
- The tax usage of the logistics charge supplier, if available; otherwise, the tax usage of the purchase order line site

Table 7.7 lists the inbound logistics tax types and the related standard tax transaction type.

Table 7.7
Inbound Logistics Tax Types

Function	Standard Tax Type	Logistics Tax Type
Purchase Order Maintenance Blanket Order Maintenance Blanket Order Release to PO Build PO from Requisitions	20	48
PO Fiscal Receiving	23	26
Purchase Order Receipts PO Shipper Receipt	21	27

Outbound Tax Calculations

The calculation of taxes on outbound logistics charges is similar to the tax calculation that occurs for the associated order. Unique logistics charge tax transaction types are used. These tax transaction types can be used to distinguish the tax on the freight accrual from the standard transaction tax.

Table 7.8 lists the outbound logistics tax types and the related standard tax transaction type. Distribution orders do not have a standard tax type since unless you are using Logistics Accounting, taxes are not calculated.

Table 7.8
Outbound Logistics Tax Types

Function	Standard Tax Type	Logistics Tax Type
Sales Quote Maintenance	10	40
Sales Order Maintenance	11	41
Sales Order Maintenance (when generating an EMT PO)	20	48
Distribution Order Maintenance	N/A	42
Sales Order Shipments	13	43
Pending Invoice Maintenance (when shipping)		
Shipper Confirm		
Shipper Unconfirm		
RMA Maintenance (when shipping or receiving)		
RMA Shipments		
RMA Receipts		
SO Shipper Maintenance	14	44
DO Shipment	N/A	45
RMA Maintenance	36	46

Accrual Currency

The system determines the accrual currency for inbound and outbound logistics charges as follows:

- For *inbound* charges, the system always uses the base currency.
- For *outbound* charges, the system uses the order (freight list) currency and the logistics supplier currency to determine the accrual currency:
 - When the order currency and logistics supplier currency are the same, the system uses the order currency for logistics accruals.
 - Otherwise, the system uses the base currency.

Accruing Inbound Logistics Charges

After you have defined inbound accrual, expense, and variance accounts and assigned them to logistics charges codes, you can begin the accrual process. Inbound logistics charges accrue during PO receipts.

Fig. 7.13
Inbound Accrual Work Flow

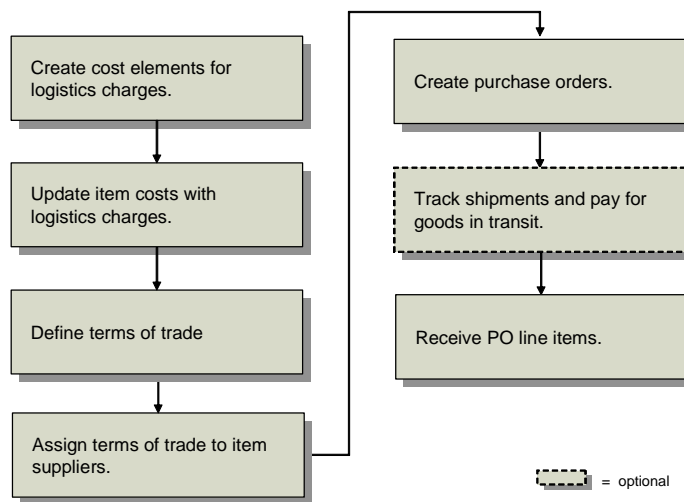

Creating Logistics Cost Elements

Use Cost Element Maintenance (30.17.1) to set up separate cost elements for logistics charges in the GL cost sets assigned to sites that receive purchased items. The cost elements must be in the Material or Overhead cost category. See *User Guide: QAD Costing* for more information on cost elements and product costing.

Create a cost element for each logistics charge you want to accrue. For example, you could create separate cost elements for domestic freight and overseas freight, or create only one cost element for freight. Associate logistics cost elements with individual logistics charge codes in Logistics Charge Code Maintenance (2.15.1).

In the corresponding current cost sets, add the same logistics cost elements in the same cost category only when Costing Method is set to Last in Cost Set Maintenance (30.1). When the last cost method is used, the system can update current logistics costs when pending invoices are matched in receiver matching. When the costing method is Average or None, logistics costs are not updated in the current cost set.

Note Whether receiver matching updates costs depends on the setting of Current Cost from AP in Inventory Control (3.24). When this is Yes, receiver matching updates the logistics charge cost element in the current cost set associated with PO line items. Otherwise, the cost update does not occur.

Updating Item Costs

Use Item-Element Cost Maintenance (30.17.5), Item Cost Maintenance (1.4.9), Item-Site Cost Maintenance (1.4.18), or Item Master Maintenance (1.4.1) to add logistics cost elements associated with logistics charges to purchased items in the GL cost set and enter this-level logistics costs for those items. You must enter GL cost values in order to accrue logistics charges during purchase receipts.

Add the same cost elements to the current cost set when the last cost method is used for current costs. The value of the current cost will be updated when logistics charges are matched if Current Cost from AP is Yes in Inventory Control.

Defining Terms of Trade

Terms of trade define both the logistics charges associated with purchasing items from external suppliers and the party responsible for paying each. These trade terms are specific to the purchase of items and define the obligations of the customer and seller for the delivery of goods. Terms of trade are also referred to as *Inco Terms*. Inco Terms are defined by the International Chamber of Commerce and used in international contracts.

Terms of trade only apply to the logistics charges associated with the delivery of goods, not the terms of payment for those logistics charges. Define payment terms in Credit Terms Create (36.1.10.1).

During purchase receipts, the system determines which logistics charges to accrue based on the terms of trade assigned to the purchase order. When the receiving site is responsible for a logistics charge payment, the logistics charge is accrued since the charge is payable to a third-party logistics supplier, not the item supplier. Logistics charges are not accrued when they are the responsibility of the item supplier.

Use Terms of Trade Maintenance (2.15.4) to indicate who is responsible for arranging the transportation of goods, define each logistics charge associated with a purchase, and indicate whether you (the customer) or the item supplier is responsible for the logistics charge payment.

When you (the customer) are responsible for transporting the goods, the system automatically populates the Transit Days field when a new order is created in Purchase Order Maintenance (5.7), Blanket Order Maintenance (5.3.1), and Supplier Scheduled Order Maintenance (5.5.1.13) with the Transit Days value in Delivery Transit Time Maintenance (2.16.1).

Each terms-of-trade record can include all of the logistics charges associated with a purchase, with the responsible party assigned to each logistics charge.

See “Tracking Shipments and Paying for Goods-In-Transit” on page 219.

Fig. 7.14
Terms of Trade Maintenance (2.15.4)

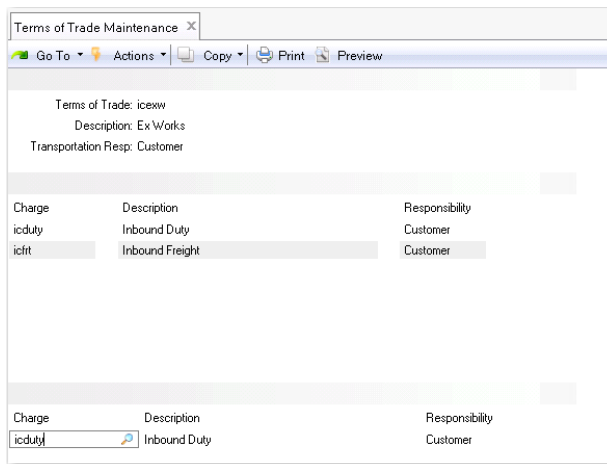

Terms of Trade. Enter a code (8 characters) identifying the terms of trade.

Description. Enter a brief (24 characters) description for the terms of trade.

Transportation Resp. Assign the party responsible for providing the transportation for purchased items from the supplier to the destination site.

Customer: The site receiving the PO line items is responsible for arranging transportation from the supplier to their site.

Supplier: The item supplier is responsible for shipping the items.

Charge. Enter a logistics charge code to include in these terms of trade.

Description. This field displays the description defined in Logistics Charge Code Maint.

Responsibility. Assign the party responsible for paying the logistics charge.

Customer: The site receiving PO line items is responsible for the logistics charge payment. This charge is accrued during purchase receipts when Logistics Accounting is active.

Supplier: The item supplier is responsible for paying this logistics charge. No accrual takes place.

Assigning Terms of Trade to Suppliers

Assign default terms of trade to applicable item suppliers in Supplier Data Maintenance (2.3.1). The default terms of trade are used when the supplier is entered on the order header of a purchase order, blanket order, or supplier scheduled order.

See “Setting Up Supplier Data” on page 179.

Note When a PO is created automatically from requisitions in Build PO from Requisitions (5.2.18) or from an EMT order during sales order processing in Sales Order Maintenance (7.1.1), the default terms of trade assigned to the item supplier are used. When default terms of trade are not found, logistics charges do not accrue for these orders.

Fig. 7.15
Supplier Data Maintenance, Logistics Accounting Data

The screenshot shows a software window titled "Supplier Data Maintenance" with a menu bar containing "Go To", "Actions", "Copy", "Print", and "Preview". The window is divided into three main sections:

- Supplier Address:** Displays details for Supplier: ICSUP01, Business Relation: ICSUP01, Name: IC Supplier 1, Address: IC Supplier 1 Address1, City: Sydney, State: AUS, Post: [2], Country: AUS, Attention: [2], Telephone: [2], and Fax: [2]. There is an "Active" checkbox which is checked and an "Added" field.
- Supplier Terms Data:** Shows "Cr Terms: 2/40PRDX", "Discount Percent: 0.00%", "Partial OK" checkbox, and "DB Number" and "CoC Number" fields.
- Logistics Accounting Data:** Contains a "Terms of Trade" field with the value "icexw" entered.

Terms of Trade. Enter the default terms of trade for this supplier.

Processing Purchase Orders

When you create an order in Purchase Order Maintenance (5.7), Blanket Order Maintenance (5.3.1), or Scheduled Order Maintenance (5.5.1.13), you can specify the terms of trade. The same logistics accounting frames and fields are used in all three programs. See *User Guide: QAD Purchasing* for details on purchase orders.

The system automatically copies terms of trade to the PO when orders are created by releasing a blanket order using Blanket Order Release to PO (5.3.6)

Note When you use Build PO from Requisitions (5.2.18) to create a PO, the default terms of trade assigned to the item supplier are used. When default terms of trade are not found, logistics charges do not accrue for these orders. See “Assigning Terms of Trade to Suppliers” on page 215.

After you enter the terms-of-trade code, you can optionally display the terms-of-trade detail lines and assign a logistics supplier to each charge that is your (customer) responsibility. Logistics charges that are the responsibility of the item supplier do not display.

Fig. 7.16
Purchase Order Maintenance, Logistics Accounting Data Frame

Header			
Purchase Order: 0815:YM	Supplier: icsup01	Ship-To: MD100	
Supplier		Ship To	
IC Supplier 1		Central Headquarters	
IC Supplier 1 Address1		1 Penn Plaza	
Sydney		Newark	NJ 07102
AUS		United States	
Logistics Accounting Data			
Terms of Trade: icexw	Show Detail: <input type="checkbox"/>		
Transport Days: 0	Transportation Resp: Customer		

Terms of Trade. Enter the terms-of-trade code used to accrue logistics charges for this order. This field defaults from the terms-of-trade code associated with the supplier in Supplier Maintenance. When this field is blank, logistics charges do not accrue for this order.

Transportation Resp. Displays whether the customer or item supplier is responsible for arranging transportation.

Transport Days. When Transportation Resp is Customer, enter the number of calendar days to transport goods from the item supplier to the PO ship-to site. Defaults to the Transit Days value in Delivery Transit Time Maintenance (2.16.1) based on the PO supplier address and the ship-to site. When Transportation Resp is Supplier, this value must be 0 (zero).

Show Detail. Enter Yes to display details for the specified terms of trade.

Fig. 7.17
Logistics Accounting Detail Frame

Charge	Description	Log Supplier	Name
iclduty	Inbound Duty		
icfit	Inbound Freight		

Log Supplier. Enter the supplier of the selected logistics charge.

After you enter a PO line item, the system recalculates the PO line item unit cost to exclude logistics costs that are your responsibility, since they are not payable to the item supplier, except when one of the following is true:

- A price list with an amount type of L (list) is attached to the PO. The system uses the list price from the price table. Price lists are defined in Price List Maintenance (1.10.2.1). See “Using List/Discount Table Pricing” on page 86.
- A supplier quote price is available. The PO line item unit cost defaults from the supplier quote price defined in Supplier Item Maintenance (1.19) for the item and supplier. See “Customer and Supplier Items” on page 15.

Otherwise, the system checks the GL cost set for any cost element in the Material category for that line item. If a cost element is linked to a logistics charge code belonging to the PO terms of trade and the charge is your responsibility, the value of the cost element is excluded from the PO unit cost.

If you change the terms of trade or assign a different code to the PO, the system does not recalculate unit costs for existing line items. You can manually update the PO unit cost of each line item or use Purchase Order Cost Update (5.19) to automatically recalculate and update the unit costs.

Example Table 7.9 shows how the unit cost of an item on a PO line is calculated when price lists are applied. In this example, the PO line item has a Material cost element with a value of \$10 and a Freight cost element in the Material cost category with a value of \$1 in the GL cost set. The PO terms of trade indicate that the customer is responsible for freight.

Table 7.9
PO Unit Cost Calculations with Price Lists Applied

Price List	Amount Type	Price List Value	PO Unit Cost	PO Discount	PO Net Unit Cost
PL1	L (list)	\$11.50	\$11.50	0.0%	\$11.50
PL2	D (discount)	5.0%	\$10.00	5.0%	\$9.50
PL3	P (price)	\$6.66	\$10.00	33.4%	\$6.66
PL4	M (markup)	7.5%	\$10.00	-7.5%	\$10.75

When PL1 is used, the system uses the list price. When PL2, PL3, or PL4 are used, the system subtracts the value of the Freight cost element from the PO unit cost. If Logistics Accounting is not enabled, the PO unit cost is \$11.

PO Shippers

When you use PO Shipper Maintenance (5.13.14) or PO Fiscal Receiving (5.13.16) to record PO line items and quantities listed on formal shipping documents or packing lists, the system prompts for additional logistics accounting information.

Fig. 7.18
PO Shipper Maintenance (5.13.14)

The screenshot shows a web-based form titled "PO Shipper Maintenance". At the top, there are fields for "Supplier: ICSUP01", "Shipper ID: 1234567", "Ship Date: 12/4/2008", "IC Supplier 1 Name", and "IC Supplier 1 Address". Below this, there are fields for "Ship-to ID: ic-site1" and "IC Site 1". The main section contains several input fields: "Carrier Shipment Ref:" with the value "0003429-T", "Carrier Shipment Ref2:", "Ship Via:", "FOB Point:", "Mode of Transport:", "Vehicle/Vessel ID:", "Voyage/Flight Number:", "Origin of Goods:", "Port of Departure:", and "Port of Arrival:". To the right of these fields, there is a "Status:" label and a "Comments:" checkbox. Further right, there are date fields for "Ship Date: 12/4/2008", "Arrive Date:", and "Due Date: 11/20/2008". At the bottom, there is a "Contents:" field.

Carrier Shipment Ref. Enter the shipment reference number from the carrier, such as a bill of lading number, carrier tracking number, or packing slip number. The shipment reference is used during receiver matching to help match pending invoices to invoices from logistics suppliers.

When terms of trade are assigned to POs attached to the shipper, each PO line must have the same terms-of-trade code assigned; otherwise, an error displays. The terms-of-trade code assigned to the first PO line is applied to the entire shipper or container.

After you finish entering line items, the terms-of-trade details display. You can specify a supplier for each logistics charge that is your responsibility.

Fig. 7.19
PO Shipper Maintenance, Logistics Accounting Detail Frame

The screenshot shows the "Logistics Accounting Detail" section of the "PO Shipper Maintenance" form. It features a table with the following columns: "Charge", "Description", "Log Supplier", and "Name". The table contains two rows of data:

Charge	Description	Log Supplier	Name
icduty	Inbound Duty		
icfrt	Inbound Freight		

There are also empty input fields for "Log Supplier" and "Name" for each charge.

Log Supplier. Enter the third-party supplier for this logistics charge.

Tracking Shipments and Paying for Goods-In-Transit

Typically, a company creates a purchase order and sends it to the item supplier who may be local or in another country. The supplier ships the goods to a company location where the customer receives the goods. Depending on the contract terms, ownership, risk, and liability for the goods may transfer to the customer when the goods are shipped or when the goods arrive at their destination. When ownership is transferred, the supplier prints a sales invoice and sends it to the customer who then begins the process to pay the supplier.

When the transit time for purchased goods takes place over an extended period of time—such as goods shipped by sea between continents—the customer ordering the goods is typically responsible for organizing the shipment of the goods through a third-party freight company. Since the item supplier is not responsible for delivering the goods to the customer, the supplier expects payment as soon as the goods are collected from their premises. The item supplier sends an invoice to the customer, which must be paid before the goods physically arrive at their destination.

In this situation, the system lets you receive goods into transit locations and process payment for those goods while they are still in transit.

Fig. 7.20
Overview of Importing Activities

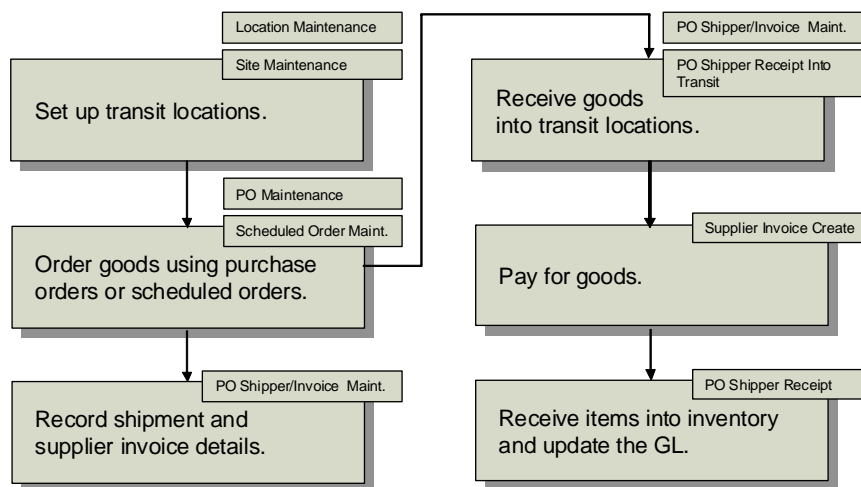

Setting Up Transit Locations

Use Location Maintenance (1.1.18) to create a transit inventory location. This location does not represent a physical location where goods are stored. Rather, it is used to track all items on PO shippers that are currently in transit to your company, letting you record the liability for the items and process payment for supplier invoices before the goods physically arrive.

See “Locations” on page 46.

Ensure that the inventory status code assigned to this location is set to not available (the goods are still in transit) and not nettable. Otherwise, MRP considers the supply in that location twice: once for the scheduled receipt and again for the nettable quantity in the location. Use Inventory Status

Code Maintenance (1.1.1) to create a code that sets inventory status to not available and not nettable. You can also restrict transactions to prevent the inadvertent issue of inventory from the transit location by other programs.

See “Inventory Status Codes” on page 50.

After a transit location is created, assign it to a site using Site Maintenance (1.1.13). One transit location is used to track all purchased goods currently in transit to the specified site. Inventory is received into this location by PO Shipper Receipt Into Transit (5.13.19) or PO Shipper/Invoice Maintenance (5.13.18) and transferred out of this location by PO Shipper Receipt (5.13.20).

See “Sites” on page 40.

Note It is recommended that you use Inventory Account Maintenance (1.2.13) to specify an inventory account for the transit location so that goods in transit are tracked separately in the GL from goods that have actually been received.

PO Shippers Combined with Supplier Invoices

Use PO Shipper/Invoice Maintenance (5.13.18) to create a single record that combines shipment details with supplier invoice details, record the associated inbound logistics charges, and receive goods into a transit inventory location.

See *User Guide: QAD Purchasing* for details on creating shipper/invoices.

Shipper/invoices support companies where:

- The shipment of purchased items requires an extended transit time.
- The company is responsible for organizing the shipment of goods from an item supplier.
- Item suppliers expect payment for their goods before they arrive at the ship-to destination.

You can continue to add new supplier invoices to an existing shipper/invoice and receive the associated PO line items into the transit location. Items received into a transit location cannot be updated.

After shipment information, supplier invoice details, and PO line items are recorded, the system prompts for additional logistics accounting and transit information. The logistics accounting detail frame is the same as PO Shipper Maintenance shown in Figure 7.19.

After logistics suppliers are specified, the system prompts for the following transit information:

GL Effective Date. Enter the date when this transaction affects the general ledger. Default is the system date. This date has no effect on the inventory balance update. Inventory balances are updated immediately when Receive Shipper Into Transit is Yes.

Receive Shipper Into Transit. Indicate whether to receive the items associated with the PO shipper into the transit location specified for the shipper ship-to site.

Note You can also use PO Shipper Receipt Into Transit (5.13.19) to receive shippers created in PO Shipper Maintenance, PO Fiscal Receiving, and PO Shipper/Invoice Maintenance into a transit location.

Important When a PO shipper is received into a transit location, you cannot update the details of existing invoices and the shipper cannot be deleted. However, you can update the shipment details in the header frame and you can also add new invoices. The system requires that you receive the new invoices into the transit location or delete the new records before you exit the program. This functionality is provided to allow you to make corrections to shipper/invoices when invoice errors are made by item suppliers.

Receiving goods into a transit location:

- Receives the items on the PO shipper into the transit location specified for the shipper ship-to site.
- Creates RCT-PO inventory transactions.
- Creates a pending supplier invoice and receiver for each PO line on the shipper.
- Creates a pending supplier invoice for each logistics charge on the shipper.

Note Logistics charges apply to the entire shipper, not each invoice on a combined shipper.

- Creates GL transactions for the receipt into the transit location and the logistics charge accrual amounts.
- Calculates taxes on logistics charges.
- Updates the PO shipper status from Unconfirmed to In Transit.

Note Receiving goods into a transit location will not update the associated PO lines with the receipt quantity. For MRP purposes, the PO line quantities on the shipper are considered scheduled receipts until the goods physically arrive at the ship-to site and are received into inventory using PO Shipper Receipt.

Processing Purchase Receipts

During purchase receipt processing in Purchase Order Receipts (5.13.1) or PO Shipper Receipt (5.13.20), a pending invoice record is created for each logistics charge associated with a purchase receipt that is your responsibility.

Note PO Fiscal Receiving (5.13.16) does not perform a PO receipt or create pending invoices. After using this program to set up a shipper, you must use PO Shipper Receipt to actually receive the items on the shipper.

Receiving PO line items:

- Creates pending invoices for logistics charges
- Creates GL transactions for the logistics charge accrual amounts
- Calculates tax on logistics charges

When a pending invoice is created in Purchase Order Receipts, the receiver number is used as the internal reference and the packing slip number is used as the external reference. Pending invoices created in PO Shipper Receipt use the shipper number as the internal reference and the carrier shipment reference from the PO shipper as the external reference.

For each PO line received into inventory, the system checks each cost element for that line item in the Material or Overhead category in the GL cost set. If the cost element is linked to a logistics charge code belonging to the PO terms of trade and the charge is your responsibility, a pending invoice is automatically created for that logistics charge.

The logistics charge accrual value is calculated as follows:

$$\text{Accrual Value} = \text{PO line receipt quantity} * \text{logistics charge cost element value}$$

Note Only one pending invoice is created for each logistics charge associated with a purchase receipt. When the same logistics charge is linked to another line item cost element, a detail line is added to the pending invoice for that logistics charge and the accrual value is updated.

For example, if a shipper contains 5 POs and each PO contains 10 line items that are each subject to freight and duty charges, PO Shipper Receipt creates two pending invoices—one for freight and one for duty. Each pending invoice will contain 50 detail lines.

GL Effects

In addition to the GL transactions created during PO receipt for item material cost, the following GL transactions are created for each PO line received with an associated logistics charge:

- Debit Inventory for the PO line logistics charge accrual value.
- Credit the inbound Accrual account for the logistics charge, product line, site, and supplier type for the same amount.

For example, a PO line item with a freight cost of \$1 per item is received in a quantity of 50. Inventory is debited \$50 and the inbound accrual account associated with the freight logistics charge is credited \$50.

Note The system always uses the base currency as the accrual currency for inbound logistics charges.

If the tax code associated with a logistics charge has Accrue Tax at Receipt set to Yes in Tax Rate Maintenance (2.13.13.1), the system creates the following GL transactions:

- Debit AP Tax Recoverable for the logistics charge tax accrual amount.
- Debit the inbound Variance account for the logistics charge tax variance amount.
- Credit the inbound Accrual account for the tax accrual and tax variance amounts.

The tax accrual and tax variance values are calculated as follows:

$$\text{Tax Accrual} = \text{PO line receipt qty} * \text{logistics charge cost element value} * \text{tax rate} * \text{percent recoverable}$$

$$\text{Tax Variance} = \text{PO line receipt qty} * \text{logistics charge cost element value} * \text{tax rate} * (1 - \text{percent recoverable})$$

Purchase Order Returns

When a PO line item is returned for credit or replacement, the system does not reverse the original accrued value of the logistics charges. This is because some logistics charges, like freight or insurance, could be payable to a third-party supplier regardless of whether the items are returned.

When PO line items with associated logistics charges are returned using Purchase Order Returns (5.13.7), the system creates the following GL transactions:

- Debit the inbound Expense account for the accrual value.
- Credit Inventory for the same amount.

Important Do not return items with associated logistics charges by entering negative numbers in Purchase Order Maintenance. You must use Purchase Order Returns to post the correct GL transactions to update the logistics charge accounts.

Accruing Outbound Logistics Charges

After you have defined outbound accrual, expense, and variance accounts and assigned them to logistics charges, you can begin the accrual process for outbound logistics charges. Outbound logistics charges accrue during shipments.

Fig. 7.21
Outbound Accrual Work Flow

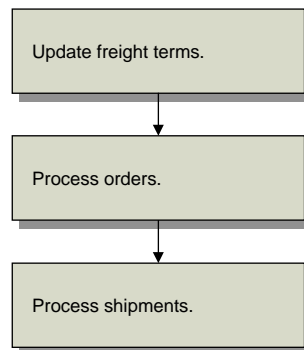

Updating Freight Terms

Assign a logistics charge to each freight term with an accrual level in Freight Terms Maintenance (2.20.13). The system uses the type code to determine whether freight charges are accrued and, if so, at what level—at the order line or for the entire shipment. See “Setting Up Freight Charges” on page 185 for details on freight terms.

The level of accrual is determined as follows:

- **No Accrual.** When Type is 4 (Collect) or 6 (Will Call), logistics charges do not accrue. A logistics charge cannot be assigned to either of these freight terms.
- **Accrue by Shipment.** When Type is 1 (Add) or 2 (Allow), logistics charges are accrued for the entire shipment. Calculated freight amounts are tracked using the outbound accrual and expense accounts defined for the logistics charge code in Logistics Charge Code Maint (2.15.1).
- **Accrue by Line.** When Type is 3 (Prepaid) or 5 (Include), logistics charges are accrued for each order line item. Calculated freight amounts are tracked using the accrual and expense accounts defined for the logistics charge code in Outbound Accrual Account Maint (2.15.16) and Outbound Expense Account Maint (2.15.19). If detail accounts are not defined in these programs, the system uses the outbound accrual and expense accounts defined for the logistics charge code in Logistics Charge Code Maint.

When logistics charges are accrued by shipment or by order line, you must assign the logistics charge code used to track the logistics charges incurred and payable to a third-party carrier.

Fig. 7.22
Freight Terms Maintenance (2.20.13)

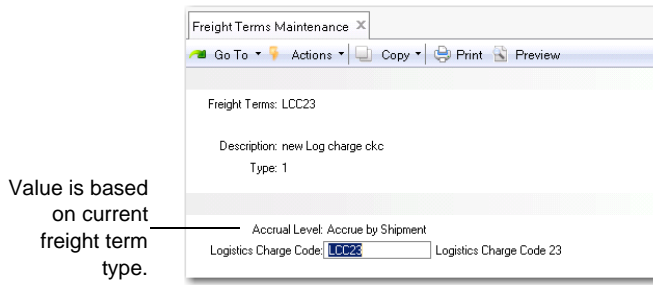

Logistics Charge Code. Enter a code identifying a logistics charge. When Type is set to 4 (Collect) or 6 (Will Call), logistics charges are not accrued. The lower frame displays but cannot be updated.

Processing Orders

During order maintenance, the logistics charge code associated with the freight term and the default supplier, if any, are displayed. The logistics supplier can be changed.

The same logistics accounting frames and fields are used in the following programs and their related shipping programs:

- Sales Order Maintenance (7.1.1)
- Sales Quote Maintenance (7.12.1)
- Pending Invoice Maintenance (7.13.1)
- RMA Maintenance (11.7.1.1)
- Distribution Order Workbench (12.17.13)
- Distribution Order Maintenance (12.17.14) and Distribution Order Processing (12.17.21)

See *User Guide: QAD Sales* for more information on sales orders.

After you have finished entering order line items, the logistics accounting detail frame displays when:

- Logistics Accounting is enabled.
- A freight terms code is specified on the order header.
- The freight terms code indicates an accrual level of shipment or line.
- A freight list is specified on at least one order line.

Fig. 7.23
Sales Order Maintenance, Logistics Accounting Detail Frame

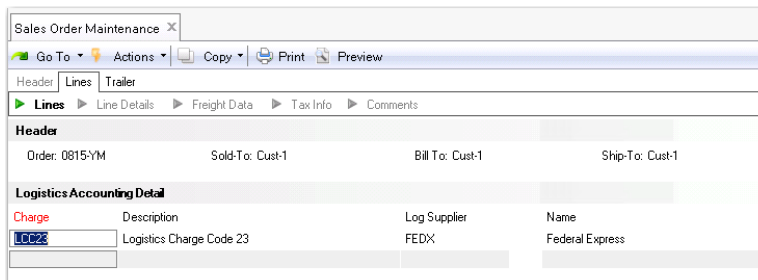

Log Supplier. Enter an address code identifying the freight carrier responsible for transporting this order.

This field cannot be blank. If necessary, you can change the supplier during shipment processing.

When logistics data exists on a sales quote or order, this data is included by the following copy and release functions:

- Sales Quote Copy from Order (7.12.5)
- Sales Quote Copy from Quote (7.12.6)
- Sales Quote Release to Order (7.12.10)

Distribution Orders

When Logistics Accounting is not active, you cannot associate freight data with distribution orders. When Logistics Accounting is active, you can specify freight terms and lists in an additional frame.

Figure 7.24 illustrates the frame that displays for input of freight data in Distribution Order Maintenance (12.17.14).

Fig. 7.24
Distribution Order Maintenance, Freight Data

The screenshot shows a window titled "Freight Data" with the following fields and values:

- Freight List: LCC23
- Freight Minimum Weight: 10
- Freight Terms: LCC23
- Calculate Freight:
- Display Weights:

These fields are similar to the freight fields that display in Sales Order Maintenance. When you set Display Weights to Yes, the system displays a freight frame for each line item. In this frame, you can override the Freight Class and Freight Ship Weight that defaults from the item master.

The freight terms code determines whether you are prompted for a logistics supplier. In distribution orders, only some freight term types have significance. Since freight terms only apply to distribution orders when freight accrual is involved, type 4 (Collect) or type 6 (WillCall) have no meaning. Type 5 (include) also has no meaning for DOs since no item pricing is involved.

When using Logistics Accounting in distribution orders, select one of the following freight term types:

- 1 (ADD): Freight is calculated and accrued by shipment.
- 2 (ALLOW): Freight is calculated and a negative amount is accrued by shipment.
- 3 (PREPAID): Freight is calculated and accrued by line.

Customer Scheduled Orders

Logistics charges accrue on customer scheduled orders only when the ship-to customer in Scheduled Order Maintenance (7.3.13) has a default freight list and freight terms code defined in Customer Maintenance (2.1.1). Charges accrue when the default freight terms indicate an accrual level of shipment or line.

Shippers

When you use Container Workbench (7.7.1) or SO Container Maintenance (7.7.5) to create containers, the first sales order line item sets the freight terms for the entire container. The system verifies that items added from other order lines have the same freight terms as the first order line added.

These containers are then referenced on shippers using Sales Order Shipper Maintenance (7.9.8) or Pre-Shipper/Shipper Workbench (7.9.2). When you select sales order items for shipment, you can update the logistics supplier associated with the attached sales order in the Logistics Accounting Detail frame shown in Figure 7.23.

Each sales order attached to the shipper or container on a shipper must use the same freight terms; otherwise an error displays. The freight terms code assigned to the first sales order line is applied to the entire shipper.

Note You can combine sales order lines with and without freight lists on the same shipper or container.

Processing Shipments

When you process a shipment, the logistics charge code and the logistics supplier are displayed. The supplier can be updated if necessary. Before logistics charges can be accrued during the shipment process, a logistics charge code, logistics supplier, and shipment identifier must be defined.

Processing shipments:

- Creates pending invoices for logistics charges
- Creates GL transactions for the logistics charge accrual amounts
- Calculates tax on logistics charges

The system uses the freight terms assigned to an order to determine whether an accrual is created for each order line or the entire shipment. See “Updating Freight Terms” on page 223.

The system calculates freight charges based on the order, customer or ship-to site information, and freight information entered in the programs on the Freight Charges menu. See “Setting Up Freight Charges” on page 185.

Note Only one pending invoice is created for each shipment or shipper. When logistics charges are accrued by order line, detail lines are added to the pending invoice and the accrual value is updated.

Discrete Shipments

Processing a discrete shipment in any of the following programs creates a pending invoice when the freight terms assigned to the order or line indicate an accrual level of shipment and a freight list is specified on at least one order line:

- Sales Order Shipments (7.9.15)
- Pending Invoice Maintenance (7.13.1)
- Distribution Order Processing (12.17.21) or Shipments (12.17.22)

- RMA Maintenance (11.7.1.1), Shipments (11.7.1.16), or Receipts (11.7.1.13)

Note You can ship and receive from RMA Maintenance.

When Logistics Accounting is active, additional frames and fields display. The same frames and fields that display in Sales Order Shipments also display in the other programs.

Fig. 7.25
Sales Order Shipments, Logistics Accounting Detail

Charge	Description	Log Supplier	Name
10023	Logistics Charge Code 23	FEDX	Federal Express

Log Supplier. This field defaults from the logistics supplier specified on the order, but you can change it.

Fig. 7.26
Sales Order Shipments, Shipment ID

Shipment ID. If the NRM sequence code specified in Logistics Accounting Control is an internal sequence, leave this field blank to have the system assign a number. Otherwise, enter a sequence number. The system validates it against the Sales Order Shipment Sequence ID specified in Logistics Accounting Control. See “Sales Order Shipment Sequence ID” on page 205.

When a pending invoice is created in discrete shipment programs, the shipment ID number is used as the internal reference and the bill of lading (BOL) number is used as the external reference.

Note If you have set up shipping groups and inventory movement codes, you can create formal shipping documents in distribution order shipping functions. In this case, you are not prompted for a shipment ID; the shipper number is used instead.

Shippers

During the confirmation process in Pre-Shipper/Shipper Confirm (7.9.5) or Pre-Shipper/Shipper Auto Confirm (7.9.7), a pending invoice is created and freight charges accrued based on the freight terms assigned to the first sales order attached to the shipper.

Each sales order attached to the shipper must have the same freight terms code; otherwise, an error displays.

Pending invoices created during confirmation use the shipper number as the internal reference and the carrier shipment reference from the shipper as the external reference.

Unconfirming a shipper in Shipper Unconfirm (7.9.21) reverses the freight accrual created during confirmation.

Return Material Authorizations (RMAs)

RMAs are limited to the receipt of items returned by customers and the issue of replacement items. In RMA Maintenance (11.7.1.1), you can receive items returned by a customer as well as ship replacement items back to the customer. RMA Maintenance performs the functions of both RMA Receipts (11.7.1.13) and RMA Shipments (11.7.1.16). See *User Guide: QAD Service/Support Management* for details on RMAs.

In all three programs, you can define the logistics supplier and enter a shipment ID used as the internal reference when a pending invoice is created. Since RMAs are similar to sales orders, the logistics accounting fields and processing are the same as Sales Order Maintenance and Sales Order Shipments.

GL Effects

During shipment, the system creates a GL transaction for the entire shipment or for each line, depending on the freight terms.

A sales order shipment creates the following GL transactions:

- Debit the Sales Order Expense account for the logistics charge, product line, site, customer type, and channel.
- Credit Sales Order Accrual for the logistics charge, product line, site, and supplier type.

A distribution order shipment creates the following GL transactions:

- Debit the Distribution Order Expense account for the logistics charge, product line, site, customer type, and channel.
- Credit the Distribution Order Accrual account for the logistics charge, product line, site, and supplier type.

Accrual Currency

For outbound logistics charges, the system uses the order (freight list) and logistics supplier currencies to determine the accrual currency.

- If the order currency is the same as the logistics supplier currency, that currency is used for accruals.
- Otherwise, the system uses the base currency for accruals.

Updating Pending Invoices

Use Logistics Charge Pending Invoice Maintenance (2.15.7) to update a logistics supplier on an open pending invoice. You cannot update pending invoices closed during matching in Receiver Matching Create (28.2.1). For convenience, Logistics Charge Pending Invoice Maintenance is also located on the Accounts Payable menu as 28.12.

Although you can match invoice amounts from logistics suppliers to pending invoices with blank suppliers in Receiver Matching Create (based on the control setting), it is easier to match pending invoices when logistics suppliers are assigned.

When you receive more than one invoice for the same logistics charge, you can enter the supplier from the first invoice and match the amount, then change the supplier on the pending invoice before matching the second invoice.

Example A single pending invoice is created for freight and you receive two invoices, one from a shipping agent for transporting the goods to a local port and another from a local carrier for transporting the goods from the dock to your company warehouse.

Fig. 7.27
Logistics Charge Pending Invoice Maintenance (2.15.7)

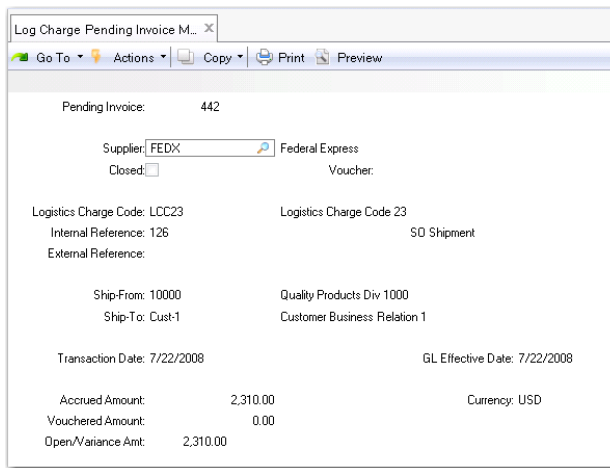

Pending Invoice ID. Enter a number identifying a pending invoice.

Supplier. Enter a logistics supplier. Entering a supplier does not update the original order.

No other fields can be updated in this program.

Table 7.10 shows the sources for the internal and external reference fields when pending invoices are created for logistics charges.

Table 7.10
Internal and External Reference Sources

Program	Internal Reference	External Reference
Purchase Order Receipts (5.13.1)	Receiver Number	Packing Slip Number
PO Shipper Receipt (5.13.20)	Shipper Number	Carrier Shipment Ref
Pre-Shipper/Shipper Confirm (7.9.5)	Shipper Number	Carrier Shipment Ref
Pre-Shipper/Shipper Auto Confirm (7.9.7)	Shipper Number	Carrier Shipment Ref

Program	Internal Reference	External Reference
Sales Order Shipments (7.9.15)	Shipment ID	Bill of Lading
Pending Invoice Maintenance (7.13.1)	Shipment ID	Bill of Lading
RMA Maintenance (11.7.1.1) RMA Receipts (11.7.1.13) RMA Shipments (11.7.1.16)	Shipment ID	Bill of Lading
Distribution Order Processing (12.17.21) Distribution Order Shipments (12.17.22)	Shipment ID	Bill of Lading
Distribution Order Processing and Shipments with shipping groups	Shipper Number	Carrier Shipment Ref

Matching Logistics Charges

When invoices arrive from logistics suppliers, use the Logistic Charge tab of Receiver Matching (28.2.1) to match the accruals on pending invoices to the logistics supplier invoice for payment.

See *User Guide: QAD Financials* for details on receiver matching.

See “Apportioning Logistics Charges” on page 197.

GL Effects

When you indicate that matching is complete against a logistics charge by setting Close Line to Yes, the system calculates the variance, if any, as the difference between the invoice amount and the accrued amount less the invoiced amount. Any difference is posted to the variance account for the logistics charge. Variances are calculated but not recorded when Close Line is No.

An invoice to a logistics supplier for logistics charges accrued during a purchase receipt creates the following GL transactions:

- Debit the inbound Accrual account for the logistics charge, product line, site, and supplier type.
- Credit Accounts Payable for the logistics supplier.

An invoice to a logistics supplier for shipments to customers creates the following GL transactions:

- Debit the Sales Order Accrual account for the logistics charge, product line, site, and supplier type.
- Credit Accounts Payable for the logistics supplier.

An invoice to a logistics supplier for shipments to other company locations creates the following GL transaction:

- Debit the Distribution Order Accrual account for the logistics charge, product line, site, and supplier type.
- Credit Accounts Payable for the logistics supplier.

When the shipping and receiving sites are in different entities or databases, the system automatically generates the appropriate balancing entries in the GL for each site using the Intercompany debit and credit accounts defined in Entity Code Maintenance (25.3.1.1).

See *User Guide: QAD Financials* for details on intercompany accounts.

Deleting and Archiving Logistics Charges

The system keeps all of your unmatched pending invoices online for an unlimited time. There is no automatic purge of this information at period or year end. To delete pending invoices for logistics charges that have not been, or are not expected to be, matched, use Uninvoiced Logistics Charge Delete/Archive (28.21).

First, run the program without actually deleting any records by setting Delete to No. Review the resulting report before setting Delete to Yes; then run the program again to delete the pending invoices that match the selection criteria. When Archive is Yes, the system copies the selected records to an ASCII file that can be reloaded using Archive File Reload (36.16.5).

Generating Logistics Reports

Table 7.11 lists logistics accounting reports and inquiries with a brief description of their purpose.

Table 7.11
Logistics Accounting Reports

Report	Description
Logistics Charge Code Inquiry (2.15.2)	Displays details for individual logistics charge codes.
Terms of Trade Inquiry (2.15.5)	Displays the logistics charge codes and responsibilities associated with a terms-of-trade code.
Inbound Account Inquiry (2.15.14)	Displays account, sub-account, and cost center information maintained in Inbound Account Maint.
Outbound Accrual Account Inquiry (2.15.17)	Displays account, sub-account, and cost center information maintained in Outbound Accrual Account Maint.
Outbound Expense Account Inquiry (2.15.20)	Displays account, sub-account, and cost center information maintained in Outbound Expense Account Maint.
Logistics Charge Variance Report (28.17.13)	Displays only those logistics charges where the amount accrued differs from the amount paid.
Open Logistics Charge Report (28.17.14)	Shows all open logistics charges. Can be run with a historical date to show what was open as of a prior date.

Inventory Control

Inventory Control supports a broad range of activities including management of inventory transactions, lot/serial tracing, inventory counting, and obsolete inventory analysis.

***Introduction to Inventory Control* 234**

Introduces concepts and features of the Inventory Control module.

***Setting Up Inventory Control* 234**

Explains how to set up Inventory Control.

***Creating Inventory Detail Records* 238**

Details creating inventory detail records.

***Creating Inventory Transactions* 238**

Outlines creating inventory transactions.

***Creating Inventory Transaction History* 243**

Explains how to create inventory transaction history.

***Creating Lot/Serial Number History* 246**

Details how to create lot/serial number history.

***Performing Cycle Counts* 246**

Explains how to perform cycle counts.

***Analyzing Obsolete Inventory* 248**

Explains how to analyze obsolete inventory.

***Creating Inventory Reports* 272**

Explains how to create inventory reports.

***Checking Inventory Availability* 275**

Details how to check inventory availability.

Introduction to Inventory Control

Inventory Control supports a broad range of inventory activities. You can:

- Create inventory transactions, such as unplanned issues and receipts or inventory transfers.
- Monitor inventory transactions and history records created elsewhere in the system, including lot/serial tracing.
- Generate reports and inquiries on the value and availability of inventory.
- Perform cycle counts to verify inventory quantities on hand.
- Identify and analyze obsolete inventory so that your company financial experts can book a reserve, then use the reserve to create an inventory write-off.

Receipts to inventory and issues from inventory change a location's inventory balance and affect the general ledger (GL). Inventory Control provides a complete audit trail of all inventory transactions, and enables you to track tools, documents, and non-inventory items (but not work-in-process items).

Use it to verify inventory by performing inventory counts and comparing actual quantities with system quantities. Two counting methods are supported: cycle counting and physical inventory counting.

See Chapter 9, "Physical Inventory," for details.

Setting Up Inventory Control

Control programs let you specify two types of settings:

- Operations-related settings—such as picking logic—in Inventory Control (3.24)
- Financial settings—such as default account information—in Inventory Accounting Control (36.9.2)

Inventory Control includes:

- Inventory Count Parameters. These determine how the system handles inventory balance variations during counts. Tolerances can be set based on item ABC class. See "ABC Class Code" on page 247.
- Picking Logic. Before the system can move inventory, it must know what inventory to select, or *pick*. The picking logic specified here determines how the system picks inventory.

Fig. 8.1
Inventory Control (3.24)

The screenshot shows the 'Inventory Control' window with the following settings:

- Inventory Count Parameters:**
 - Issue Days: 7
 - Tolerance From Qty On Hand or Annual Usage: Qoh
 - Default Site: 10000
 - Item Tolerances:

Class A: 3.00%	300.00	Class C: 5.00%	500.00
Class B: 4.00%	400.00	All Others: 5.00%	500.00
- Picking Logic:**
 - 1) Location
 - 2) Lot/Serial
 - 3) Date
 - 4) Expire Date
 - Picking Order: 2
 - Ascending or Descending: Ascending

Picking Order. Enter the method to use for selecting inventory during detail allocation:

- 1–Location.* The system looks for inventory by location.
- 2–Lot/Serial.* The system looks for inventory by lot/serial number.
- 3–Date.* The system looks for inventory by the date the item was created or received.
- 4–Expire Date.* The system looks for inventory by item expiration date.

Ascending or Descending. Enter Ascending to have the system pick the oldest or lowest number first. Enter Descending to have the system pick the newest or highest number first. As an example, if Picking Order is by Date and Ascending order is specified, the first item picked is that with the oldest create or receipt date.

Settings in Inventory Accounting Control are associated with costing issues, whether GL transactions are created for inventory transactions, and other related issues.

Fig. 8.2
Inventory Accounting Control (36.9.2)

The screenshot shows the 'Inventory Accounting Control' window with the following settings:

- Accounting:**
 - Current Cost (AVG/LAST/NONE): AVG
 - Sum LL Costs Into Matl Cost:
 - Current Cost from AP:
 - Create GL Transactions:
 - Transfer Clearing Acct: 5030
 - Summarized Journal:
 - Journal Reference Method: 0

Current Cost. Specify the method to use for updating current material, labor, and burden costs. When you use the Cost Management module, this is the default update method for all sites that do not have site-specific cost sets defined in Cost Set to Site Assignment. When you do not use Cost Management, this setting applies to all sites in the system.

Average (AVG): Default. Current costs are updated during item receipts and other inventory-related activities using a simple weighted-average calculation.

Last: Each item's current cost is equal to the unit cost from the last receipt or inventory update.

None: The system does not automatically update current costs. They must be maintained manually, if needed.

Note When you use the Cost Management module, you can use the Average method to calculate site-specific GL costs as well as current costs.

To change the default costing method from Last or None to Average, you cannot have secondary (non-primary) cost elements defined. You must first set all secondary-element values for each cost category to 0 (zero), then delete the secondary cost elements using Cost Element Maintenance (30.17.1).

When the update method is Average or Last, the following system activities can update current costs:

- Receiving inventory from a work order or repetitive schedule or using Receipts – Backward Exploded.
- Running the accounting close function for a work order or cumulative order, to consider any costs posted after the last receipt.
- Transferring inventory between sites; for example, using distribution orders or inventory transfer functions.
- Receiving quantities from purchase orders or supplier schedules or returning items to a supplier using functions such as Purchase Order Returns (5.13.7).
- Matching a supplier invoice with a purchase order receipt. This reverses the effect of the corresponding purchase order receipt update and only applies when Current Cost from AP is selected.

Note Issue and shipment transactions processed with negative quantities are not considered receipts and do not update average and last costs.

To calculate average costs for materials, the following equation is used:

$$(receipt\ quantity * receipt\ cost) + (item\ quantity\ on\ hand * current\ material\ cost)$$

The result is then divided by the new quantity on hand—including the receipt—to determine the new current average cost of the item.

For manufactured items, current labor, subcontract, and burden costs are calculated for each work order or repetitive operation using the following equation:

$$(item\ quantity\ received/cumulative\ quantity\ completed\ at\ the\ operation) * operation's\ cumulative\ work-in-process\ (WIP)\ cost$$

Sum LL Costs Into Matl Cost. Specifies how lower level costs are posted to Cost of Goods Sold.

If No, lower-level costs are added to this-level costs for each cost component and the total posted to Cost of Goods Sold. For example, the total material cost (this-level plus lower-level) is posted to Cost of Goods – Material, the total labor cost is posted to Cost of Goods – Labor, and so on, for Cost of Goods – Burden, Overhead, and Subcontract.

If Yes, all lower-level costs are summarized into Cost of Goods – Material. Only this-level costs are posted to Cost of Goods – Labor, Burden, Overhead, and Subcontract.

This field does not affect the way costs are calculated or stored in cost sets.

Usually this field is set to No. Cost of goods sold amounts are maintained separately for each cost component. However, in some companies, the material cost for an end item is considered to include all costs associated with purchasing or manufacturing components, as well as any direct material costs. Then this field is set to Yes.

Current Cost from AP. Indicate whether current cost should be affected by AP Rate Variances calculated in Accounts Payable.

No: AP Rate Variances—differences between the supplier invoice cost and the purchase order cost—are not reflected in current cost.

Yes: Current material cost is updated to reflect AP Rate Variances.

Setting this field to Yes lets the system maintain current cost automatically to reflect the actual cost incurred, which you can compare to your GL (standard) cost. Current cost is updated as Last or Average. It may or may not be affected by actual supplier costs for purchased items.

Create GL Transactions. Indicate if GL transactions are to be created by inventory activities.

Yes: Inventory issues, receipts, count adjustments, and transfers create GL transactions reflecting the change in inventory asset balances. In addition, any transactions that affect work-in-process inventory create GL transactions. This includes work order issues and receipts.

No: GL transactions are not created by any of these activities.

Note This field does not impact memo item transactions. These do not create GL transactions regardless of this field.

Companies who do perpetual inventory accounting typically set this field to Yes, taking advantage of the automatic journal transactions created in the system.

Companies using periodic inventory accounting normally set this field to No. With periodic accounting, the accountant manually calculates ending inventory based on:

$$\text{Ending Inventory} = \text{Beginning Inventory} + \text{Purchases} - \text{Cost of Goods Sold}$$

Manual journal entries are then made to post the purchases and cost of goods sold amounts, since these are not posted automatically by the system.

Another alternative is to let the system create journal transactions but not post them. This is useful for creating manual journal entries under periodic accounting, or if you are using an external general ledger system. GL transactions can be printed and then deleted using GL Transactions Delete/Archive (36.23.2).

Important GL transactions can only be deleted when no IC transactions have ever been posted.

Transfer Clearing Acct. Enter the GL account, sub-account, and cost center used to track transfers within a site or between sites in the same entity. The account cannot be blank when multiple sites are defined. You must specify a valid, active account of type Standard.

Transfers between sites in different entities are tracked using the Cross-Company Inventory Control accounts associated with the domain in Domain Create (36.1.1.1) and the entity's intercompany code.

In a single-site environment, the Purchases account is used when no account is specified.

Summarized Journal. If Create GL Transactions is Yes, this field determines how GL transactions are created:

No: Detailed GL transactions are created, one per inventory transaction.

Yes: One summarized GL transaction is created based on the value of Journal Reference Method. This is based either on:

- A combination of date, entity, account, sub-account, cost center, and project
- All transactions created per user session

Note The AR amount of the transaction is always summarized for posting regardless of how you set this field.

A summarized journal takes less space and may be easier to manage in the GL. Greater detail is always available by printing transaction registers in the original module. However, if you want to analyze GL transactions using system-supplied supplementary analysis fields (SAF), you must set Summarized Journal to No. SAFs can only be used with individual detail transactions. See *User Guide: QAD Financials* for more detail on system SAF codes.

Journal Reference Method. This field controls the summarization method when field Summarized Journal is Yes.

0: Generate one summarized journal transaction for each combination of date, entity, account, sub-account, cost center, and project.

10: Generate one summarized journal transaction for each active user session.

When Summarized Journal is No, this field has no effect, but must be zero.

Creating Inventory Detail Records

Inventory detail records precisely define inventory balances and locations. Each record includes:

- Item number
- Site
- Location (if used)
- Lot/serial number (if used)
- Lot reference (if used)

The system calculates total item inventory by adding all on-hand balances from inventory detail records. Records also provide details on inventory status codes and expiration dates, grades, and assay percentages.

Modify inventory attributes using Inventory Detail Maintenance (3.1.1) or Detail Maintenance by Item/Lot (3.1.2). Use Inventory Detail by Lot Inquiry (3.1.13) to generate a report.

Creating Inventory Transactions

Inventory transactions move inventory to or from a location. Examples of inventory transactions include:

- Issuing existing inventory to a work order
- Receiving purchased materials into inventory
- Shipping goods

Fig. 8.3
Inventory Transaction Flow

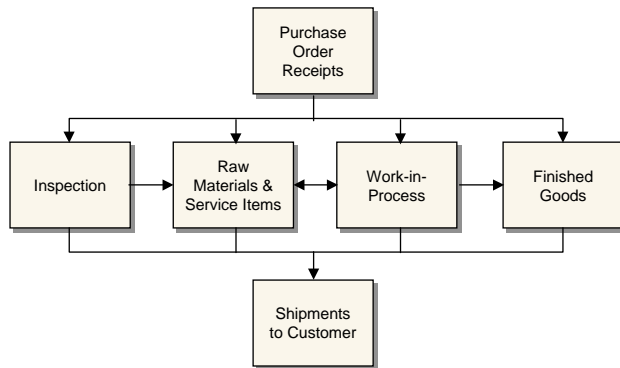

Use the programs in Table 8.1 to create inventory transactions and possibly generate shipping documents (shippers).

Table 8.1
Inventory Transfer Menu (3.4)

Menu Number	Program	Shippers
3.4.1	Transfer–Single Item	Sites and locations
3.4.2	Transfer–Multi Item	Sites and locations
3.4.3	Transfer With Lot/Serial Change	Sites and locations
3.4.4	Batchload Transfer With Lot/Serial Change	Sites and locations
3.7	Issues–Unplanned	Sites
3.8	Issues–Return to Supplier	Sites
3.9	Receipts–Unplanned	No
3.10	Receipts–Sales Order Return	No
3.11	Receipts–Return to Stock	No
3.12	Receipts–Backward Exploded	No
3.14	Scrap Transaction Maintenance	No

Transfers

A transfer is a movement of inventory to a new location. You can use three kinds of inventory transfers: single item, multi-item, and transfer with lot/serial change.

- Use Transfer–Single Item (3.4.1) to transfer a specified quantity of a single item from one location to another. If inventory status codes specified in the From and To fields differ for an item, you can select the one to be used.
- Use Transfer–Multi Item (3.4.2) to transfer more than one item from one location to another. Only entire quantities are transferred—not partial quantities. This transaction generates a report showing the items and quantities transferred.
- Use Transfer With Lot/Serial Change (3.4.3) to transfer a specified quantity of a single item from one location to another *and* change the lot/serial and lot reference numbers associated with the item.

- Use Batchload Transfer With Lot/Serial Change (3.4.4) for the same purpose as 3.4.3. However, this program also supports CIM loading of inventory information by allowing you to specify values for fields that are prompted for interactively in the standard Transfer With Lot/Serial Change.

This is especially important when using CIM load to transfer data between the system database and an external system.

See *User Guide: QAD System Administration* for details on CIM.

The system checks the GL calendar to ensure that the effective date specified for a transfer is within an open fiscal period. The default effective date is the system date. If a shipping group exists for a transfer, you can create a shipper for the transferred items.

Receipts

A receipt occurs when inventory is brought into a location. Receipts increase the quantity on hand of an item at a particular location. Use the following programs to receive inventory that does not have an existing or open order:

- Use Receipts–Unplanned (3.9) to receive miscellaneous inventory such as floor stock items sent back from production, or materials from a manufacturing order that has been closed from an accounting standpoint.
- Use Receipts–Sales Order Return (3.10) to tag a receipt as a return only if you do not use Sales Orders/Invoices. This is not a complete return since it does not update sales or commission history, and does not generate a credit invoice.
- Use Receipts–Return to Stock (3.11) to return to stock miscellaneous items that have been temporarily moved elsewhere.
- Use Receipts–Backward Exploded (3.12) to increase inventory quantity for an item at a designated site and location and decrease inventory for its components. Backward-exploded receipts are often used in kitting or simple assembly operations, where there is no need for a work order. Recording receipt of a finished item indicates that an associated set of items was used.

Issues

An issue sends inventory to a different location. For example, when components are issued to a work order, they are removed from the stocking location and issued to the work-in-process (WIP) location. Inventory issues reduce quantities on hand at the issuing location.

- Use Issues–Unplanned (3.7) to record miscellaneous inventory issues such as floor stock items sent to production or materials sent to engineers for testing. You can also issue items to a manufacturing order that closed from an accounting standpoint.
- Use Issues–Return to Supplier (3.8) to tag an issue as a return. This is not a complete return since it does not update purchasing or receiving history, or current cost. To process a complete return, use functions in the Purchasing module.

Scrap

Use Scrap Transaction Maintenance (3.14) to record removing one or more items from inventory as scrap.

Set Multi Reason to Yes, when the quantity is greater than one, to use multiple scrap reason codes. The system displays the Scrap pop-up screen where you can specify which reason code to use for each portion of the total quantity. The system creates an inventory transaction history record for the quantity assigned to each reason code. When multiple lines in the Scrap screen have the same reason code, the quantities on these lines are summed into one transaction record. The transaction type is ISS-SCRIP.

Set Multi Entry to Yes when the quantity is greater than one to assign quantities and reason codes by site, location, and lot/serial.

Note Define reason codes in Reason Codes Maintenance (36.2.17) with the Reason Type set to Scrap.

Scrap transactions debit Inventory accounts and credit Scrap accounts. With field security set, only those who are authorized can update the account fields.

- The Credit Account is the Scrap account defined in Inventory Account Maintenance (1.2.13) for the product line and site or the Scrap account defined for the product line in Product Line Maintenance (1.2.1).
- The Debit Account is the Inventory account defined in Inventory Account Maintenance for the product line and site or the Inventory account defined for the product line in Product Line Maintenance.

Scrap Transaction Maintenance is not appropriate for components that are lost or unusable as a result of the manufacturing process. For work orders use Work Order Receipt (16.11), Work Order Receipt Backflush (16.12), or Work Order Operation Backflush (16.19). For repetitive manufacturing, use Backflush Transaction (18.22.13) or Repetitive Scrap Transaction (18.18).

Fig. 8.4
Scrap Transaction Maintenance (3.14)

Debit Account: 5800	0100	Scrap
Credit Account: 1500	0100	Inventory

Reason Code. Enter a reason code to use for a scrap transaction.

When Multi Reason is No, the reason code applies to the quantity in Qty Scrapped.

When Multi Reason is Yes and Multi Entry is No, the system displays the Scrap pop-up screen with this reason code applied to the Qty Scrapped on the first line; you can split the quantity into as many as ten portions and apply different reason codes to the portions.

When Multi Entry is Yes, the system displays the Item Detail screen for specifying reason codes for portions of Qty Scrapped by site, location, and project.

Each quantity and reason code combination creates a unique Transaction History record. When the same reason code is used on multiple lines in the Scrap screen, the quantities on those lines are summed to create one Transaction History record with that reason code.

Reason codes are validated against codes set up in Reason Codes Maintenance with Reason Type set to Scrap. This field can be left blank only if a blank reason code is set up for the field in Reason Codes Maintenance.

Some reports and inquiries can be selected by reason code.

Multi Reason. Set this field to Yes to display the Scrap pop-up window for applying different reason codes to portions of the total quantity to be scrapped. The default is No.

Each quantity and reason code combination creates a unique Transaction History record. When the same reason code is used on multiple lines in the pop-up, the quantities on those lines are summed to create one Transaction History record with that reason code.

Auth Doc #. Enter the ID number for the document that authorizes the transaction. Some reports and inquiries can be selected by document ID number.

Employee. Enter the employee code of the person creating this inventory transaction. Define employees in Employee Create.

This screen displays when Multi Reason is set to Yes.

Fig. 8.5
Scrap Transaction Maintenance (3.14)

Site	Location	Lot/Serial	Reference	Qty Scrapped	Reason Code
MD300	100			2.0	Quality

Use these fields in the Scrap detail screen.

Quantity Scrapped. Enter the quantity of the item to be scrapped with a particular scrap reason code.

Multiple reason codes can be used when the total quantity to be scrapped is greater than one. If the same reason code is used for multiple partial quantities, those quantities are summed into one transaction. The sum of the partial quantities must equal Qty Scrapped.

Reason Code. Enter the scrap transaction reason code for part of the total quantity to be scrapped.

Multiple reason codes can be used when the total quantity to be scrapped is greater than one. If the same reason code is used for multiple partial quantities, those quantities are summed into one transaction. The sum of the partial quantities must equal Qty Scrapped.

Shipping Documents

Many countries require that formal shipping documents accompany any movement of goods, even when goods are merely transferred, not sold. If you are using shipping groups, you can record shipping information and generate shipping documents from all the inventory transfer and issue programs when the addresses associated with the transfer-from and transfer-to sites belong to a valid shipping group and the inventory movement codes associated with the shipping group allow transaction type ISS-TR.

Shippers are also supported for the inventory transfer programs when the addresses of transfer from and to locations are associated with a shipping group.

When you are using inventory movement codes to manage shipping, you can also specify default credit and debit accounts that are used for unplanned issues or receipts.

See the Shipping chapter in *User Guide: QAD Sales* for details.

Creating Inventory Transaction History

Every inventory transaction creates a record in the inventory transaction history table. Each record has a unique, sequential transaction number, a transaction type, and includes the following information:

- Transaction data
- Inventory data
- Cost data
- GL transaction data
- User ID of the person entering the transaction

Transaction Types

The transaction type code identifies the function used to initiate the inventory change. Table 8.2 lists the transaction type codes included in inventory history records with a brief description of each type and the name of one of the programs that creates the transaction.

Note Many of these transactions are created in more than one program. In this case, the table simply indicates a typical program associated with the transaction and is not intended to be a complete list.

Most inventory transactions create corresponding GL transactions. These transaction can be assigned to different daybooks using Default Daybook Maintenance (25.8.4). See *User Guide: QAD Financials* for details.

Inventory status code can include a list of restricted transactions. This lets you manage how items, locations, and sites are used. However, to maintain system integrity, some transactions cannot be restricted.

See “Inventory Status Codes” on page 50.

In Table 8.2, transactions that cannot be restricted appear in boldface type.

If you are using either Supplier Consignment Inventory or Customer Consignment Inventory, the system creates additional transaction types to manage consigned inventory.

See *User Guide: QAD Sales*.

Table 8.2
Inventory Transaction Types

Transaction Type	Description	Program Creating
CST-ADJ	Standard cost adjustment	Item Master Maintenance (1.4.1)
CST-TR	Cost transfer between sites	Distribution Receipts (12.15.20)
CUM-RADJ	Cumulative received adjust	Cumulative Received Maintenance (5.5.5.13)
CUM-RRES	Cumulative received reset	Cumulative Received Reset to Zero (5.5.5.14)
CUM-SADJ	Cumulative shipped adjust	Cumulative Shipped Maintenance (7.5.16)
CUM-SRES	Cumulative shipped reset	Cumulative Shipped Reset (7.5.18)
CYC-CNT	Cycle count adjustment	Cycle Count Results Entry (3.13.2)
CYC-ERR	Cycle count error	Cycle Count Results Entry (3.13.2)
CYC-RCNT	Cycle count recount	Cycle Count Results Entry (3.13.2)
ISS-CHL	Location change issue	Inventory Detail Maintenance (3.1.1)
ISS-COR	Issue sales order item on a correction invoice	Sales Order Shipments (7.9.15)
ISS-DO	Distribution order shipment	Distribution Order Shipments (12.17.22)
ISS-FAS	Final assembly order issue	Sales Order Shipments (7.9.15)
ISS-GIT	Distribution order receipts	Distributed Order Receipts (12.15.20)
ISS-PRV	Return to vendor (supplier)	Purchase Order Return (5.13.7)
ISS-RV	Return to vendor (supplier)	Issues–Return to Supplier (3.8)
ISS-SCRP	Remove from inventory as scrap	Scrap Transaction Maintenance (3.14)
ISS-SO	Issue sales order item	Sales Order Shipments (7.9.15)
ISS-TR	Inventory transfer issue	Transfer–Single Item (3.4.1)
ISS-UNP	Inventory unplanned issue	Issues–Unplanned (3.7)
ISS-WO	Issue work order item	Work Order Component Issue (16.10)
ORD-PO	Purchase order booking	Purchase Order Maintenance (5.7)
ORD-SEO	Material order booking	Material Order Maintenance (11.11.1)
ORD-SO	Sales order booking	Sales Order Maintenance (7.1.1)
PLCG-ADJ	Product Line Change	Product Line Replacement (1.2.23)
RCT-CHL	Location change receipt	Inventory Detail Maintenance (3.1.1)
RCT-DO	Distribution order receipt	Distributed Order Receipt (12.15.20)
RCT-FAS	Receive final assembly	Sales Order Shipments (7.9.15)
RCT-GIT	Distribution order shipment	Distribution Order Shipments (12.17.22)
RCT-PO	Purchase order receipt	Purchase Order Receipts (5.13.1)
RCT-RS	Inventory return to stock	Receipts–Return to Stock (3.11)
RCT-SOR	Inventory sales order return	Receipts–Sales Order Return (3.10)

Transaction Type	Description	Program Creating
RCT-TR	Inventory transfer receipt	Transfer–Single Item (3.4.1)
RCT-UNP	Inventory unplanned receipt	Receipts–Unplanned (3.9)
RCT-WO	Receive work order item	Work Order Receipt (16.11)
RJCT-WO	Reject work order item	Work Order Receipt (16.11)
TAG-CNT	Physical inventory update	Inventory Balance Update (3.16.21)
WIP-ADJ	Work-in-process adjustment	WIP Material Cost Revaluation (16.22)
WO-CLOSE	Work order close	Work Order Accounting Close (16.21)

Reviewing Transaction History

Use the programs on the Transaction History Menu (3.21) to view inventory transaction history.

- Use Transactions Detail Inquiry (3.21.1) to display detailed inventory transaction history records ordered by transaction number.
- Use Transactions by Item Browse (3.21.2) to display inventory transaction history for an item number ordered by transaction date, starting with the most recent.
- Use Transactions by Order Browse (3.21.4) or Transactions by Order Report (3.21.13) to display inventory transaction history by sales order or work order number.
- Use Transactions by Order Report (3.21.13) to display inventory transaction history by sales order or work order number.
- Use Transactions by Item Report (3.21.14) to display inventory transaction history by item number.
- Use Transactions Accounting Report (3.21.16) to display the costed GL transactions created for each transaction.

Note An enhanced version of Transactions Accounting Report is available on menu 3.21.40 in QAD .NET UI only.

- Use Average Cost Accounting Report (3.21.17) to list selected transactions involving average cost computations. The report shows quantity, unit cost, and inventory value for the beginning balance, the change data, and the ending balance.
- Use Transaction Numbering Report (3.21.19) to review inventory transaction history by number or date range.

Note Sequence numbers apply to the database as a whole; as a result, transactions within a domain may appear to have gaps. This report lets you see transactions created in all domains and verify that numbering is sequential.

- Use Transactions Delete/Archive (3.21.23) to remove transactions from the system when online history is no longer needed.
- Use Transactions Detail Report (3.21.25) to display detailed inventory transaction history records ordered by transaction number.

Note This enhanced report is available only in QAD .NET UI.

Creating Lot/Serial Number History

Lot/serial control is an inventory attribute assigned in Item Master Maintenance (1.4.1). When you mark an item as lot/serial controlled, you cannot issue or receive the item without specifying a number.

As transactions are processed for an item, its lot/serial number is included in transaction history. Lot/serial numbers provide greater tracking control by creating records of an item's movement through the manufacturing process.

Note The optional WIP Lot Trace module (WLT) affects lot/serial collection and reporting features, while adding detailed component, work in process (WIP), and finished goods lot/serial tracing and reporting options. WIP Lot Trace is available as menu option 3.22.13. For details, see the *User Guide: QAD Manufacturing*.

To review lot/serial history information, use the programs on the Lot/Serial Number Menu (3.22).

- Use Lot Transactions by Date Browse (3.22.1) to review an item's inventory transactions by date.
- Use Lot Transactions by Tran Browse (3.22.2) to review an item's inventory transactions by transaction number.
- Use Lot Actual Bill Inquiry (3.22.3) to display components used to make a lot/serial controlled item.

Show Duplicates. Enter Yes to allow transactions to appear more than once in an inquiry display. For example, a purchase receipt (RCT-PO) can appear once in relation to a work order issue (ISS-WO) and again in relation to an inventory status change (ISS-CHL). Enter No to have transactions appear only in the first sequence found.

Max Workfiles. Enter a number telling the system how many workfiles to create during execution. The default is 500. Entering a value greater than your system's processing capacity can cause the system to fail. To reduce the number of workfile records, narrow the range of items selected.

- Use Lot Where-Used Inquiry (3.22.4) to display all top-level items containing a lot/serial numbered component.

Show Duplicates. Enter Yes to allow transactions to appear more than once in an inquiry display. Enter No to have transactions appear only in the first sequence found.

Performing Cycle Counts

You can count and compare actual, on-hand inventory balances with system-maintained quantities using either of two counting methods:

- Cycle counting (Inventory Control)
- Physical counting (Physical Inventory). See Chapter 9, "Physical Inventory," for details.

In each method, you count inventory by site, location, item, and lot/serial number. Cycle counting involves counting groups of items on a regular or cyclic schedule. A physical count involves counting all items, usually once a year.

During cycle counting, you enter manual count figures in the system. The system then compares the manual count figures with its figures. If there are discrepancies, the system checks the error tolerances defined in Inventory Control. If a count figure is within tolerance, it is accepted and the system figure is updated. If a count figure is not within tolerance, the item in question must be recounted. The system accepts recount quantities that are out of tolerance.

ABC Class Code

The ABC class code classifies items by their importance in a manufacturing system and determines count frequencies. Class A items are counted more frequently than class B items. Class B items are counted more frequently than class C items.

Use Item Master Maintenance (1.4.1) or Item Inventory Data Maintenance (1.4.5) to assign ABC class. You can also have the system calculate it automatically by running Item ABC Status Report/Update (1.5.9 or 3.6.3). Optionally, that function lets you exclude items based on item status code.

For each ABC class, assign item tolerances (percentage and amount) in Inventory Control. When count discrepancies arise, the system checks item tolerances by class.

Cycle Counting Procedure

Whether you select items for cycle counting or have the system select them, the basic steps are as follows:

- 1 Print a cycle count worksheet.
- 2 Count the items listed on the worksheet.
- 3 Enter the initial count quantity in the system.
- 4 Review the results and enter recount quantities if necessary.

Printing Cycle Count Worksheet

Use Cycle Count Worksheet Print (3.13.1) to print a worksheet listing items selected for cycle counting, their locations, ABC code, last count date (if applicable), and the quantity on hand. Use the worksheet to record the count quantities.

The system selects items by comparing the current date with the item's last count date. If the elapsed time is greater than the period specified in the Cycle Count Interval field in Item Master Maintenance, the system selects the item for cycle counting. If this is the first time you are cycle counting an item, the system selects it by item number.

Entering Initial Count

Enter the count quantity in Cycle Count Results Entry (3.13.2). When entering the initial count quantity, set Cycle Count Type to I (Initial).

If the count quantity for an item does not match the system quantity, the system checks to see if the count is within both the percent tolerance and the amount tolerance specified for the ABC class in Inventory Control (3.24). If it is, the system updates the quantity accordingly. If the count is not within tolerance, the item must be recounted.

Fig. 8.6
Cycle Count Results Entry (3.13.2)

The screenshot shows the 'Cycle Count Results Entry' window with the following data:

Cycle Count Type (I/R): Initial	Tolerance Method: Qoh
Item Number: 5700	Tolerance Percent: 3.00%
Site: 10000	Tolerance Amount: 0.00
Location:	GL Cost: 0.00
Lot/Serial:	Last Count:
Reference:	Qty on Hand: 0.0
Description:	
Quantity Counted: 145.0	Qty On Hand Variance: 100.00%
Unit of Measure: EA	Annual Usage Variance:
UM Conversion: 1.0000	Amount Variance: 0.00
Remarks:	
Effective Date: 03/13/2007	
Dr Acct: 1500 99	Cr: 5900
Amount: 0.00	

Entering a Recount

Use Cycle Count Results Entry (3.13.2) to enter recount figures. Set Cycle Count Type to R (Recount). If a recount quantity is still out of tolerance, the system alerts you to this, but nevertheless updates its figures.

Reporting Cycle Count Results

After completing the cycle count, use Cycle Count Results Report (3.13.3) to generate a count report showing:

- Items counted
- In-tolerance quantity
- In-tolerance percent
- Items recounted

Analyzing Obsolete Inventory

Use the programs in the Obsolete Inventory Analysis menu (3.5.1) as an analysis tool to identify inventory investments that depreciate and future demand for inventory. Once you identify and analyze obsolete inventory, your company financial experts can book a reserve, then use the reserve to create an inventory write-off.

Because improperly valued inventory can cause problems in company financial statements, the obsolete inventory analysis tool calculates an inventory supply value based on current inventory usage for specific inventory types over a predefined period. You define the inventory types. You can also create and assign depreciation rates for each inventory type.

You can use the obsolete inventory analysis tool to calculate demand for future inventory. You can choose to add the demand calculations to coverage calculations or use the greater of the two calculation results when determining the coverage.

You can specify transactions to extract for analysis; then either extract using Extract Consumption (3.5.1.7) or using Obsolete Inventory Analysis (3.5.1.9). Obsolete Inventory Analysis calculates the number of periods of supply coverage and the value of obsolete inventory reserve based on depreciation rates.

Obsolete inventory analysis programs summarize and organize analysis data in several reports or for output to several formats. The analysis data provides essential information that lets you reduce inventory and save costs as your company monitors usage and obsoletes any outdated or no-longer-used items. After you analyze data, you can choose to delete or archive the data you extracted for analysis.

Obsolete Inventory Analysis Programs

Table 8.3 lists programs for obsolete inventory analysis.

Table 8.3
Obsolete Inventory Analysis Programs

Menu Number	Description	Program Name
3.5	Inventory Analysis Menu	
3.5.1	Obsolete Inventory Analysis Menu	
3.5.1.1	Inventory Type Maintenance	icobtmt.p
3.5.1.3	Depreciation Rate Maintenance	cobdmt.p
3.5.1.5	Output File Type Maintenance	icobomt.p
3.5.1.7	Extract Consumption	icobex.p
3.5.1.9	Obsolete Inventory Analysis	icobrp.p
3.5.1.13	Inventory Type Item Report	icobtrp.p
3.5.1.14	Item Inventory Type Report	icobirp.p
3.5.1.15	Depreciation Rate Browse	icobdiq.p
3.5.1.17	Output File Type Browse	icoboiq.p
3.5.1.19	Consumption Report	icobcrp.p
3.5.1.20	Consumption Delete/Archive	icobcarc.p
3.5.1.24	Obsolete Inventory Control	icobpm.p

Setting Up Obsolete Inventory Analysis

You must complete setup tasks before you analyze inventory. Figure 8.7 depicts the setup flow.

Note Although defining depreciation rates is discussed as a setup task, you can define rates at any time.

Fig. 8.7
Setup Flow

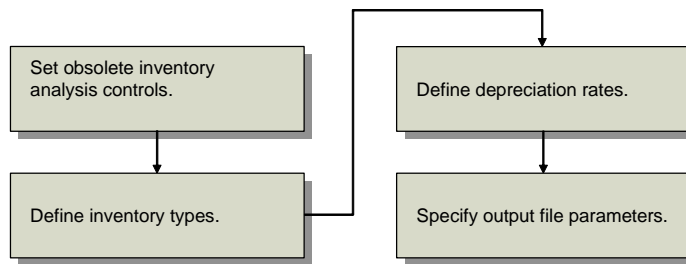

Setting Obsolete Inventory Controls

Fields in Obsolete Inventory Control (3.5.1.24) set system defaults for obsolete inventory analysis and reporting functions.

Fig. 8.8
Obsolete Inventory Control (3.5.1.24)

Inventory Type Logic. Indicate how you want the system to display fields associated with an inventory type in Inventory Type Maintenance (3.5.1.1), Inventory Type Item Report (3.5.1.13) and Item Inventory Type Report (3.5.1.14).

The system can display the fields as a logical expression in a Logical Expression frame or it can display the field label and any values or value ranges for the fields in a Field Value Ranges frame; see Figure 8.9.

No (the default): Do not display logical expressions for definitions. Display the field label and values for the field in From and To fields.

Yes: Display logical expressions for definitions.

Example In Inventory Type Maintenance, you specify an inventory type that includes items A20 to A40. You set Field Number to 3 for item type, Value Number to 1 for the first set of values for item type, From to A20 and To to A40.

Fig. 8.9
Inventory Type Maintenance (3.5.1.1), Field Display

Field Value Ranges	
->	Item Number A20 A40

Field value ranges display when Inventory Type Logic is No.

Logical Expression	
->	if (Item Number >= 'A20' and <= 'A40')

Logical expressions display when Inventory Type Logic is Yes.

Conflicting Inventory Types. Specify the action to take when items that overlapping inventory types are found when calculating obsolete inventory values.

BESTFIT (default): Choose the first inventory type with the highest number of fields.

BYPASS: Do not analyze if conflicting. No analysis data is reported where conflicts exist. The system reports conflicts if Report Conflicts is Yes in Obsolete Inventory Analysis.

FIRST: Choose the first inventory type in alphabetical order.

You specify inventory types in Inventory Type Maintenance. The system uses the course of action you specify when it encounters items in overlapping inventory types within a site when it performs coverage and reserve calculations in Obsolete Inventory Analysis.

You can run Item Inventory Type Report (3.5.1.14) to show conflicts before you analyze obsolete inventory. In the report, set Conflicts Only to Yes to display items in conflicting inventory types only. Also, you can set Report Conflicts to Yes in Obsolete Inventory Analysis to show inventory type conflicts when you run obsolete inventory analysis calculations.

See “Defining Inventory Types” on page 253.

Use ABC Analysis Usage. Specify whether to have the system use the average daily usage extracted from existing ABC analysis for obsolete inventory analysis.

No: The system does not use extracted ABC analysis data when it performs obsolete inventory calculations. The system uses the issue transactions you previously extracted in Extract Consumption (3.5.1.7) or it extracts issue transactions as needed when you run Obsolete Inventory Analysis.

Yes: The system uses extracted ABC analysis data when it performs obsolete inventory calculations. Consumption data is not needed for analysis when the system uses ABC analysis data.

ABC analysis extracts past issue transactions for particular transaction types and stores an average daily issues quantity. ABC classification is based on annual dollar usage of inventory where:

- Class A inventory items have the highest annual usage and receive the most attention.
- Class B items have lower annual usage and are controlled using reorder point.
- Class C items have the lowest annual usage. For class C, inventory value is determined by annual usage, unit cost, lead time, space available for storage, and quality.

See “ABC Class Code” on page 247.

Retain Consumption Data. Indicate whether to retain item consumption data the system uses during obsolete inventory analysis.

No (the default): The system does not retain consumption data and you cannot run Extract Consumption or Consumption Report (3.5.1.19). The system stores values temporarily during obsolete inventory analysis.

Yes: The system retains a table of consumption data by item, site, and period; displays the table in Consumption Report; and lets you build extractions in Extract Consumption. The system also retains the quantity on hand (QOH) balance by item, period, year, and site if you set Extract Quantity on Hand to Yes in Extract Consumption (3.5.7).

You must specify Yes if you want to:

- Extract consumption data using Extract Consumption.
- Retain item consumption data in the system and display it later in Consumption Report.

The system retains consumption data for each item/site by GL year and GL period.

The system also stores consumption data by GL quarter; however, since GL calendars do not identify quarters, the system calculates quarters by dividing the number of periods in the fiscal year of the transaction's effective date by four, truncating to a whole number for the first three quarters, and placing the remainder in the last quarter. Hence, a 13-period year consists of 3, 3, 3 and 4 periods.

Note You can filter consumption data by specifying a filtering program in the Consumption Filter Program field.

Consumption Filter Program. Enter the name of the program the system uses to filter consumption data it extracts for obsolete inventory analysis. The default filter program is `icobexb.p`. If you leave this field blank, the system extracts all data.

The input to `icobexb.p` is the record ID of the transaction history record. You can customize `icobexb.p` so that it filters specific record IDs. Commented sections are included in `icobexb.p` that provide instructions to customize it. You can also create your own filter program and enter it here.

Last Transaction Extracted. This field is display only and lists the system date and time of the last inventory transaction the system extracted in Extract Consumption (3.5.1.7). This field also displays in in Extract Consumption.

Path for Reserve Output. Specify the path that the system uses when you write obsolete inventory analysis data into an output file that you can optionally define in Output File Type Maintenance (3.5.1.5). A blank indicates the system creates the output file in the working directory. Use your system's conventions to specify path and directory.

Site. Specify a site to use when gathering past transactions for obsolete inventory analysis. Leave blank for all sites.

The system analyzes obsolete inventory by calculating how many periods the current quantity on hand will last based on the consumption quantity over a past period. When you specify a site here, the system gathers transactions from this site only.

Extract Issue Transactions. Specify the types of transactions you want the system to extract when analyzing obsolete inventory. Separate multiple transaction types with commas. By default, the following four types are used:

ISS-SO: Issue sales order item.

ISS-WO: Issue work order item.

ISS-UNP: Inventory unplanned issue.

ISS-DO: Distribution order shipment.

The system analyzes obsolete inventory by calculating how many periods the current quantity on hand will last based on the consumption quantity over a past period. When you specify a transaction type here, the system extracts only issue transactions of that type from inventory transaction history and uses the data to analyze items at a specified site or all sites. You can add other transaction types. The system does not verify that transaction types exist.

Note You specify the site in the Site field.

Defining Inventory Types

Use Inventory Type Maintenance (3.5.1.1) to select and group similar items into a unique inventory type. Use Depreciation Rate Maintenance (3.5.1.3) to apply a set of depreciation rates to the inventory type.

See “Defining Depreciation Rates” on page 256.

In Inventory Type Maintenance, you define the inventory type. The system stores the inventory type and a specific logical structure for the inventory type. You define the logical structure by specifying:

- A number that identifies a set of related fields. Each type can have multiple sets of associated fields.
- A number for each item-related field that you want to display in obsolete inventory reports and output data that shows inventory types.

Note The number is associated with a field in Language Detail Maintenance (36.4.2).

- A value number that identifies one value or value ranges for the fields.
- A single value or a range of values for the fields.

Use the following procedure to create an inventory type. Examples follow the procedure.

- 1 Enter a new name in Inventory Type.
- 2 Optionally, enter a short description of the inventory type in Description.
- 3 Optionally, define a field set to group one set of fields. The field set must be an integer greater than zero.
- 4 Enter the number in Field Number that corresponds to the field you want to display in obsolete inventory reports and output data. Select from the following item fields or use the lookup browse to select the number.

Table 8.4
Field Number Values

Field Number	Field Label
1	Item number
2	Product line
3	Item type
4	Group
5	Commodity code
6	ABC class

Field Number	Field Label
7	Purchase/Manufacturing Code
8	Site

- 5** If the item field has only one value or range of values, enter 1 in Value Number. If you define a second value or range of values for the same item field, enter 2 in Value Number, and so on.
- 6** Choose one of the following:
- a** Define a single value for an item field by entering the same value in From and To.
 - b** Define a range of values for an item field by entering the first value in the range in the From field and the last value in the range in the To field.

The item fields you select and the From and To values for the fields display in the Field Value Ranges frame. An arrow points to the current field set, field number, and values you defined in the top portion of the screen. Optionally, you can display your selected item fields and values for the fields in a logical expression by setting Inventory Type Logic to Yes in Obsolete Inventory Control (3.5.1.24). When Yes, a Logical Expression frame displays instead of a Field Value Ranges frame.

Inventory Type Examples

The following paragraphs provide examples of the various ways you can define the structure of an inventory type.

Example Define a single-value inventory type based only on one field. Create an inventory type based only on site 1000 by using the following values:

Field Set:	1
Field Number:	8 (site)
Field Value:	1 (the first value for site)
From:	1000
To:	1000

Example Define multiple values for a single field. Create an inventory type that contains item type AAA and item types BBA through BBC by using the following values:

Field Number:	3 (item type)
Value Number:	1 (the first value for item type)
From:	AAA
To:	AAA
Value Number:	2 (the second value for item type)
From:	BBA
To:	BBC

Example Define multiple fields for a field set. Create a field set that contains field type AAA and all purchased items for site 2002 by using the following values:

Field Set:	5
Field Number:	3 (item type)
Value Number:	1 (the first value for item type)

From: AAA
 To: AAA
 Field Number: 7 (Pur/Mfg)
 Value Number: 1 (the first value for Pur/Mfg)
 From: P
 To: P
 Field Number: 8 (site)
 Value Number: 1 (the first value for site)
 From: 2002
 To: 2002

Item Inventory Type Overlapping

Because of the way that you group items, it is possible to assign items to more than one inventory type. When the system encounters items in overlapping inventory types during obsolete inventory analysis, it uses the course of action you specify in the Conflicting Inventory Types field in Obsolete Inventory Control (3.5.1.24) when calculating coverage and reserve in Obsolete Inventory Analysis.

If you specify that the system not analyze obsolete inventory data when a conflict is found, the system does not include the item in the analysis. If you want an obsolete inventory analysis for the items in overlapping inventory types, you must correct the way items are grouped in this program.

To avoid this rework, run Item Inventory Type Report (3.5.1.14) before you run Obsolete Inventory Analysis. Item Inventory Type Report displays items in multiple classifications and specifically marks items with conflicting inventory types. Optionally, you can set the report to display only items with conflicting inventory types. You can also report conflicting inventory types when you run or execute the analysis in Obsolete Inventory Analysis.

See “Setting Obsolete Inventory Controls” on page 250.

Inventory Type Maintenance

Use Inventory Type Maintenance (3.5.1.1) to create inventory types. Enter the inventory type name and description in the header. Define multiple sets of fields in the Field Value Range frame.

Fig. 8.10
Inventory Type Maintenance (3.5.1.1)

The screenshot shows a software window titled "Inventory Type Maintenance". The window has a standard header with "Inventory Type Maintenance: Go To" and "ACTIONS". Below the header, there are two input fields: "Inventory Type:" and "Description:". Underneath these is a section titled "Field Value Range" which contains several fields: "Field Set:", "Field Number:", "Value Number:", "From:", and "To:". At the bottom of the window, there is another section titled "Field Value Ranges".

Item Inventory Type. Enter a unique name no longer than eight characters for the inventory type.

Description. Enter a brief description of the inventory type.

Field Set. Enter a number that identifies a set of fields. Each inventory type can have multiple sets of fields associated with it.

Field Number. Enter a number from one to eight that identifies a field from the item/site records. You can select the field from a list of fields in the lookup browse. You cannot leave this field blank.

You can enter a range of values for the field by specifying them in the From and To fields.

Value Number. Enter a sequence number that identifies a value or range of values for the field you enter in Field Number. See page 254 for an example.

From. Enter the first value in a range of values for the associated item/site record field you specified in Field Number. Each field can have multiple values and ranges of values associated with it.

To. Enter the last value in a range of values for the associated item/site record field you specified in Field Number.

Defining Depreciation Rates

Use Depreciation Rate Maintenance (3.5.1.3) to create and assign depreciation rates for each inventory type. A rate cannot exceed 100%.

You assign depreciation rates for each inventory type; then specify a range for the number of periods the depreciation rate covers. The system applies the depreciation rate you specify up to the period you specify when calculating reserve.

Example Specify an inventory type that groups your purchased items; then set the depreciation rate so that the rate slowly increases for the next two years in periods of six months until you no longer need the purchased item. To do this, set Up to Number of Periods to 6 and Depreciation Rate at 10 percent, and click Next. Then set Up to Number of Periods to 12 and Depreciation Rate at 20 percent, and click Next, and so on. The purchased items depreciate up to 6 months by 10 percent, then up to 12 months by 12 percent.

If you do not want an inventory item type to depreciate until after nine months, specify the rate as 0 (zero) and specify Up to Number of Periods as 9. The system applies a different depreciation rate, depending upon your specification, for the next period when the nine months is over.

Note The system does not book GL transactions for reserve that it calculates using actual depreciation rates.

You can assign a separate depreciation rate for the system to use when consumption, demand, or both are zero. To do this, specify Consump(tion), Demand, or Both in the Zero Consumption/Demand field; then specify a different depreciation rate.

See page 257.

Fig. 8.11
Depreciation Rate Maintenance (3.5.1.3)

Inventory Type. Specify the inventory type to which the system applies the depreciation rate. All items associated with the inventory type are depreciated at this rate when calculating reserve.

Zero Consumption/Demand. Indicate when the system should use a different depreciation rate: None (the default): Use the depreciation rate specified when consumption, demand, or both have a non-zero value. You can specify the number of periods in Up to Number of Periods. If you enter None but specify 0 (zero) periods, the system uses the depreciation rate you specify.

Consump(tion): Use the depreciation rate specified when there is zero consumption of inventory. The system sets Up to Number of Periods to zero and you cannot edit the field.

Demand: Use the depreciation rate when there is zero demand of inventory. The system sets Up to Number of Periods to zero and you cannot edit the field.

Both: Use the depreciation rate when there is both zero consumption and demand of inventory. The system sets Up to Number of Periods to zero and you cannot edit the field.

Up to Number of Periods. Enter the number of periods this rate covers. Each value you specify indicates the high end or ending period of a range. The system increments this value by 1 to determine the starting point of the next range.

Example Enter 3 in the Up to Number of Periods field. The system stores 0 to 3 as the period range to cover. Then, enter 20 in the Up to Number of Periods field. The system sets the next period range as 4 to 20.

Specify 0 (zero) to indicate no usage. The maximum is 9999 periods.

Note Specify the maximum of 9999 to prevent coverage periods from falling out of ranges. If you specify a value other than None for Zero Consumption/ Demand, the system sets this field to 0 (zero) and you cannot edit it.

The system stores the periods and rates in a depreciation rate detail table. When you run Obsolete Inventory Analysis, the system looks up the period you specify to analyze in the depreciation rate detail table to determine in which range of periods your specified period falls.

Depreciation Rate. Enter the depreciation rate percentage for the specified inventory type. Depreciation rates do not have to sum to 100% for any range or inventory type of items; however, a rate cannot exceed 100%.

Comment. Enter a comment no longer than eight characters to mark data in obsolete inventory reports. For example, enter Excess to mark rates you assign to excess inventory items that depreciate.

The comments print with reserve data when you specify Yes to Reserve Report in Obsolete Inventory Analysis.

Setting Up Output File Types

You can optionally create an output file for obsolete inventory analysis data. Use Output File Type Maintenance (3.5.1.5) to specify how the output file converter sorts and formats the data before you run the analysis.

The system converts and formats obsolete analysis data using the output file of your choice when you run Obsolete Inventory Analysis (3.5.1.9). You specify the name of the output file in Obsolete Inventory Analysis.

See “Specifying an Output File” on page 266.

The output data can include the following:

- Eight fields that determine the inventory type. See Table 8.4 on page 253.
- Additional fields of item data
- All system-calculated obsolete inventory analysis fields, including the reserve amount

The additional fields and the system-calculated obsolete inventory analysis fields include the following:

9	Inventory Type	18	Avg Issues Per Period
10	Item Description 1	19	Coverage Periods
11	Item Description 2	20	Standard Cost (Unit)
12	Inventory Account	21	QOH Standard Cost
13	Inventory Sub Account	22	Depreciation Periods
14	Inventory Cost Center	23	Depreciation Rate
15	Quantity On Hand	24	Reserve Amount
16	Total Issue Quantity	25	Depreciation Comment
17	Issue Periods		

Use Output File Type Browse (3.5.1.17) to find output files by file type, such as CSV.

Specifying Fields in the Output File

In Output File Type Maintenance, you enter a number that is associated with a field if you want that field included in the output file. You enter the sequence of the field in Extract Sequence.

Example To include item number as the first field and item type as the second field that display in the output file, use the following procedure:

- 1 Enter 1 for item number in Field Number or select item number from the lookup browse; then click Next.
- 2 Enter 1 in Extract Sequence; then click Next.
- 3 Enter 3 for item type in Field Number; then click Next.
- 4 Enter 2 in Extract Sequence; then click Next.

Output File Types

The `icobrpdp` default converter program creates flat files in CSV (comma-separated values) format. CSV files contain values as a series of ASCII text lines with column values that are separated by commas. A CSV file is a way to collect data from a table so that you can input it to another table-oriented application, such as a relational database application or spreadsheet.

If you specify Separator Character as blank instead of a comma (,) and Quote Character as a quote (“), the default converter program can convert files as Progress export files.

Fig. 8.12
Output File Type Maintenance (3.5.1.5)

Output File Type. Specify the output file type for the obsolete analysis data. For example, if you use a converter program that produces data in a comma-separated values (CSV) format, enter CSV. You cannot leave this field blank. The system includes the default `icobrpdp` converter program that converts data to CSV format.

Description. Enter a description of the output file.

Header Row. Indicate if you want to include a header row of field labels in the output file. You specify the fields in Field Number.

No: The system does not add a header row to the output file.

Yes: The system adds a header row to the output file.

Separator Character. Enter the character the converter program recognizes as a separator character. For example, comma-separated value (CSV) programs recognize the comma (,) as a separator character.

Quote Character. Enter the character the output file processing program recognizes as a quote. For example, comma-separated value (CSV) programs recognize quotation marks (") to mark actual data.

Program Name. Specify the name of the converter program that processes the output file. The system includes two converter programs:

- `icobrpdp` (the default): This program converts reserve data to comma-separated value (CSV) format.
- `icobrpep`: This program lets you capture the main reserve data but does not convert data into a format as complex as CSV format.

You can create your own program to convert reserve data by copying either converter program; then follow commented sections in the programs to make changes.

Field Number. Enter a number that represents a field the converter program includes in the output file. Use the lookup browse to select the field number. See “Specifying Fields in the Output File” on page 258.

Extract Sequence. Enter a number to indicate the sequence of the associated field as displayed in the output file. For example, if you enter 1 in Field Number for the item number, enter 1 here to display the item number as the first field in the output file.

To display a field at the end of the display, enter a large number. For example, if you have seven fields that display, enter 25. The system displays this field last but automatically renumbers the field so that it is in consecutive order. The system also renumbers fields in consecutive order when you delete a field.

Extracting Data for Analysis

Before the system can analyze obsolete inventory, it extracts the data to be analyzed. You can optionally extract data at any time using Extract Consumption (3.5.1.7), as long as you extract before you run Obsolete Inventory Analysis (3.5.1.9). If you do not extract data using Extract Consumption, the system extracts data at the time you perform the analysis. If you set Retain Consumption Data to Yes in Obsolete Inventory Control (3.5.1.24) and you previously extracted data using Extract Consumption, the system uses the previously extracted data when you run the analysis.

If you extract data before the analysis using Extract Consumption, the system retains the data in a table. Depending on the length of time from which you extract transactions and the number of transactions, extraction can be time consuming. To avoid the system overhead associated with creating and maintaining the consumption table in Extract Consumption, you can extract data in Obsolete Inventory Analysis. When you extract in Obsolete Inventory Analysis, the system stores the data in temporary tables, then deletes the data.

You specify the type of transaction data you want the system to extract in Extract Issue Transactions in Obsolete Inventory Control (3.5.1.24). The system extracts data from the transactions to determine inventory consumption. The system extracts consumption data based on item, site, year, and period. See page 252.

You can specify how consigned inventory displays in the Customer Consigned and Supplier Consigned fields if you use the optional Customer Consignment Inventory or Supplier Consignment Inventory modules. You can also optionally include non-nettable or negative inventory.

You specify one of two methods to extract consumption:

- Initial extraction of all data starting at the date you specify up to the current date
- Incremental extraction of transactions since the previous extraction

Incremental extraction starts at the next transaction after the last transaction date and time the system recorded and displays in the Last Transaction Extracted field in this program and in Obsolete Inventory Control. The system extracts every transaction from the date in Last Transaction Extracted up to the time you initiate the extraction. The system then overwrites Last Transaction Extracted with the current extraction date.

If you set Extract Quantity on Hand to Yes, the system extracts the quantity on hand (QOH) balance as of the extraction date for both initial and incremental builds.

The system creates a consumption history record (iach_hist) with 0 (zero) consumption, if some QOH exists and there is no consumption in the specified period. It creates the history record only for the last period, if there are multiple periods involved in a single extraction and no consumption.

You should set the following controls and options in Obsolete Inventory Control before you extract consumption data:

- Set Retain Consumption Data to Yes. If set to No, you cannot extract and store data.
- Set Use ABC Analysis to No. If set to Yes, the system uses existing ABC analysis data when you run Obsolete Inventory Analysis (3.5.1.9).
- Specify a specific site for transactions or leave Site blank for all sites.
- Optionally, specify transaction types to extract.
- Optionally, specify a filter program for extracted data or use the default filter program.

See “Setting Obsolete Inventory Controls” on page 250.

Use Consumption Delete/Archive to delete or archive consumption data.

Fig. 8.13
Extract Consumption (3.5.1.7)

Build. Indicate the method you want this program to use to extract consumption data.

Initial: Extract all data starting at the date you specify in Consumption From Date up to the current date. The system collects transaction data and builds consumption data by item, site, year, and period.

Incremental: Extract all transaction data since the previous extraction. Incremental extraction starts with the first transaction that occurred after the last transaction date and time the system stores and displays in Last Transaction Extracted in this program and in Obsolete Inventory Control. The system extracts every transaction from the date in Last Transaction Extracted up to the time you initiate the extraction. The system then overwrites Last Transaction Extracted.

Consumption From Date. Enter the date for an initial build of consumption data. The system extracts consumption data from this date up to today’s date. The system stores consumption data by item, site, year, and period. The system uses the GL calendar to convert transaction dates to a year and period.

Extract Quantity on Hand. Indicate if the system extracts Quantity on Hand (QOH) balances for initial and incremental builds.

No: The system does not extract the QOH balance.

Yes: The system extracts the QOH balance as of the extraction date for both initial and incremental builds.

Customer Consigned, Supplier Consigned. Specify whether the system extracts customer or supplier consignments for initial and incremental builds.

Exclude: Exclude customer or supplier consignment inventory.

Include: Include customer or supplier consignment inventory.

Only: Only customer or supplier consignment inventory.

Include Non-nettable Inventory. Indicate whether to include or exclude non-nettable inventory when calculating inventory supply usage for the quantity on hand for the items in the inventory type you specified.

No: Exclude non-nettable inventory when calculating supply usage.

Yes: Include non-nettable inventory when calculating supply usage.

Include Negative Inventory. Indicate whether the system includes negative quantity on hand (QOH) when calculating consumption.

No: The system does not use negative QOH when calculating consumption.

Yes: The system uses negative QOH when calculating consumption. The system displays items with negative QOH on coverage and reserve reports. Coverage periods and reserve amounts display as 0 (zero), not negative numbers.

Last Transaction Extracted. This field is display only and lists the system date and time of the last inventory transaction the system extracted. This field also displays in Obsolete Inventory Control.

Analyzing Obsolete Inventory

Use Obsolete Inventory Analysis (3.5.1.9) to:

- Extract inventory consumption data or optionally, use previously extracted consumption data.
- Optionally, use Quantity on Hand (QOH) balances as of the analysis date or as of the GL period end dates for the date range you specify.
- Calculate supply coverage.
- Calculate reserve.
- Optionally, include demand and either add it to consumption or use the greater of demand or consumption.
- Optionally, produce reports and output files.

Once the system analyzes data, you can optionally delete or archive the data using Consumption Delete/Archive (3.5.1.20).

Figure 8.14 depicts the general process flow.

Fig. 8.14
Processing Flow

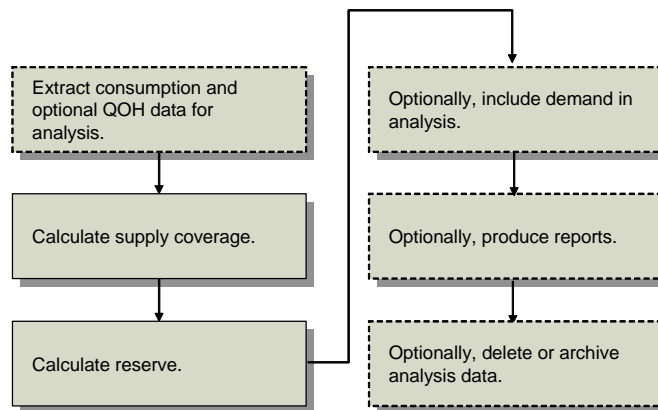

Specifying GL Periods

All obsolete inventory calculations are based on GL calendars. You specify the GL calendar period in the Period/Yr field in Obsolete Inventory Analysis (3.5.9). You can specify a period range by adding an end period and year in the To field.

Note Set up GL calendar using functions on the Financial Calendar Setup Menu (25.4).

The system bases consumption calculations on consumption from previous periods. However, if you specify a period range that includes future periods, the system multiplies the past consumption rate by the number of periods you specify to determine consumption for the entire period.

For example, if today is 06/21/05 and you specify a 12-month period for consumption from 01/2005 to 12/2005, the system analyzes consumption starting on 01/01/05 and ending on 12/31/05. Since today's date is in June, it uses the consumption from January to the end of May multiplied by 12 months to obtain the total 12-month period consumption.

If today is 06/21/05 and you specify a period from 1/2005 to 2/2005, the system analyzes consumption from 01/01/05 to the last day of the ending period, or 02/28/05.

If you specify that the system calculate demand, the period of coverage is always in the future. For example, if today is 06/21/05 and you specify a 12-month period from 01/2005 to 12/2005, the system analyzes consumption starting on 01/01/05 and ending on the last day of the month for today's date—06/30/05. It then analyzes demand starting on the first day after the end of the month for today's date—07/01/2005—up to the end of the period you specified—12/31/05.

If you specified a past period for the system to analyze demand, the system analyzes only consumption for the past period. For example, if today is 06/21/05 and you specify demand from 01/2005 to 05/2005, the system produces consumption calculations starting from 01/01/05 up to 05/31/05.

If you specify a future period for the system to analyze demand, the system starts the calculation from the first day of the month of the period you specify up to the last day of the month in the ending period you specify. For example, if today is 06/21/05, and you specify a period range of 07/2005 to 12/2005, the system starts demand calculations on 07/01/05 and ends them on 12/31/05.

Using QOH Balances

When analyzing consumption, you can optionally set Use As of QOH so that the system either:

- Uses and reports the quantity on hand as of the date you run the analysis
- Uses and reports the actual quantity on hand for the end date of every GL period within your specified period range

Example You specify a period starting on January 1, 2005 and ending on June 15, 2005 and set Use As of QOH to Yes. The system analyzes inventory using the actual quantities on hand from Jan 31, Feb 28, March 31, April 30, May 31, and June 15, 2005. If you set Use As of QOH to No, the system analyzes inventory using the quantity on hand as of the date you run the analysis.

Note When you analyze demand, the system always uses the quantity on hand as of the date you run the analysis.

The system uses the QOH balances differently when analyzing inventory, depending on whether you are adding demand to consumption or using the greater of either consumption or demand.

When you set Use As of QOH to Yes and:

- Both Add Demand and Greater of Demand are No, the calculation uses the QOH balance as of the GL period end dates that you specify in Period/Yr and To.
- Add Demand is Yes and Greater of Demand is No, the calculation uses the QOH balance based on the date you run the analysis.
- Use Greater of Demand is Yes, the calculation uses the QOH balance as of the GL period end dates within the date in Period/Yr and To for consumption and the QOH balance based on the extract date for demand.

The system reports the QOH balance along with consumption data if you set Retain Consumption Data to Yes in Obsolete Inventory Control and Extract Qty on Hand to Yes in Extract Consumption.

Extracting and Reporting Consumption

If you did not run Extract Consumption (3.5.1.7) previously and if Retain Consumption is No in Obsolete Inventory Control, you can extract consumption data by entering a GL period in the Period/Yr and To fields. The system temporarily stores the consumption data while it performs obsolete analysis on the data.

See page 251.

If you previously extracted consumption data through Extract Consumption, the system uses and reports that data based on the period and year you specify.

Set Report Consumption to Yes to report consumption data once the analysis is complete.

Calculating Number of Periods of Supply Coverage

The system calculates the number of periods of supply coverage based on the following formula:

$$[(Inventory\ QOH) / (consumption\ quantity\ for\ date\ range\ periods)] *\ entire\ date\ range\ periods$$

You specify the period or range of periods in the Period/Yr and To/Yr fields. Set Report Coverage to Yes to display supply coverage data when the analysis is complete.

Calculating and Reporting Reserve

Obsolete Inventory Analysis also calculates the value of obsolete inventory reserve. It calculates reserve values based on the following equation:

$$(\text{Depreciation rate for items specified}) * (\text{item's standard cost})$$

Set Report Reserve to Yes to display reserve data when the analysis is complete.

Calculating Demand

You can choose to have the system calculate demand. If you do, you must select one of the following for demand calculations:

- Add demand calculations to consumption calculations.
- Use the greater of the demand calculation or consumption calculation.

Note Obsolete Inventory Analysis (3.5.9) calculates both demand and consumption.

The system calculates demand quantities in the same way that MRP Summary Inquiry calculates gross requirements. That is, demand is gross requirements as currently determined by the system, excluding the quantity on hand (QOH) and scheduled receipts. MRP calculates gross requirements. Once calculated, it subtracts both the quantity on hand for the previous period and scheduled receipts to determine net requirements.

If you specify to add demand calculations to consumption calculations, the system adds demand quantities to consumption quantities based on the GL period or period range you specify. The system determines consumption using the following calculation:

$$[(\text{Inventory QOH}) / (\text{consumption quantity for respective date range periods} + \text{demand quantity for respective date range periods})] * \text{entire date range periods}$$

If you specify to use the greater of the demand or consumption calculation, the system calculates consumption and demand separately based on the GL period you specify. It determines demand using the following calculation:

$$[(\text{Inventory QOH}) / (\text{demand quantity for respective date range periods for demand})] * \text{respective date range periods for demand}$$

When Include Negative is set to Yes, the system displays items on hand with negative quantities on coverage and reserve reports. The system displays coverage periods and reserve amounts as 0 (zero), not negative numbers.

You can print demand data by setting Report Demand to Yes in Obsolete Inventory Analysis to display demand data when the analysis is complete.

See “Calculating Number of Periods of Supply Coverage” on page 264.

Note You must set either Add Demand or Greater of Demand to Yes to display demand data.

Sorting Report Data with Levels

The system sorts data for the report based on the fields you enter in Level 1 Field, Level 2 Field, and Level 3 Field. Levels are indented in the report, providing data separation and grouping.

For example, if you do not specify any level fields, the report sorts detail lines by item and site. If you specify Level 1 Field as item type, the report sorts data by item type with detail lines by item and site.

If you specify Level 1 Field as item type, Level 2 Field as ABC code, and Level 3 Field as item group, the report sorts by item type first, by ABC code second, and by item group last with detail lines by item and site.

Example The following example report has three user-selected level breaks, each with an indented header line. Detail lines are by site, item type, and item number.

Fig. 8.15
Example Report with Levels

icnbrp.p 99		3.5.1.9 Obsolete Inventory Analysis					Date:	
Page: 4		Q6 e132 V61					Time:	
Reserve Report								
Site: kpsitel								
Item Type: itatyp01								
Item Number: kpicap01								
Item Number	Site	Inv Type	Qty On Hand	Avg Issues	Cov Pds	QOH Cost	Rate	Reserve Conn
kpicap01	kpsitel 1		2,897.0	208.812	14	14,485.00	20.0	2,897.00
Item Number: Total: kpicap01						14,485.00		2,897.00
Item Number: kpicap11								

Specifying an Output File

Before you specify an output file name and file type, you must set up output file processing in Output File Type Maintenance (3.5.1.5). You specify the program that converts the output, which fields display in the output file, and other formatting in Output File Type Maintenance. You can use the system-supplied converter programs or create your own converter program. Specify the output file name and type in Obsolete Inventory Analysis (3.5.1.9).

See “Specifying an Output File” on page 266.

Note If you specify the type as CSV, you may have to add the `.csv` extension before you import into some PC-based applications.

Running the Analysis

After all obsolete inventory controls are set and you define inventory types and depreciation rates, you can analyze data.

Fig. 8.16
Obsolete Inventory Analysis (3.5.1.9)

Inventory Type/To. Enter a range of inventory types for selecting transactions to analyze.

Period/Yr. Enter the first GL period in a range of periods for which you want the system to analyze obsolete inventory. Enter the period in a two-digit format; for example, enter 06 for June.

If you ran Extract Consumption specifying a date range, the system uses that collected consumption coverage data here; so, the date you enter here should fall within the period you specified in Extract Consumption.

Enter the year after you enter the period. Enter the year in a four-digit format; for example, enter 2005.

To. Enter the last GL period of collected consumption data for which you want the system to analyze obsolete inventory. Enter the year in a four-digit format.

Customer Consigned. See “Customer Consigned, Supplier Consigned” on page 262.

Supplier Consigned. See “Customer Consigned, Supplier Consigned” on page 262.

Add Demand. Specify whether the system adds consumption data to demand data.

No: Do not add demand to consumption calculations. When both Add Demand and Greater of Demand are No, the system analyzes obsolete inventory using consumption data only.

Yes: Add demand calculations to consumption calculations. The system adds demand quantities to consumption coverage quantities. This field cannot be Yes when Greater of Demand is Yes.

Greater of Demand. Specify whether the system uses the greater of the consumption calculation or the demand calculation.

No: Do not use the greater of the demand or consumption coverage calculation. When both Greater of Demand and Add Demand are No, the system analyzes obsolete inventory using consumption coverage data only.

Yes: Use the greater of the demand or consumption coverage calculation. The system calculates consumption and demand separately, then uses the greater of the individual calculations. This field cannot be Yes when Add Demand is Yes.

Use As of QOH. When analyzing inventory, indicate whether the system uses the QOH balance as of the date you run the analysis or the actual QOH for the end date of every GL period within the period range you specify in the Period/Yr and To fields.

Note When you analyze demand, the system always uses the quantity on hand as of the date you run the analysis.

No: The system uses and reports the QOH balance as of the analysis run date.

Yes: The system uses and reports the actual QOH balance for the end date of every GL period within the period range you specify in Period/Yr and To fields. The system uses the QOH balances differently when analyzing inventory, depending on whether you are adding demand to consumption or using the greater of either consumption or demand.

See “Using QOH Balances” on page 264.

Include Non-nettable Inventory. See “Include Non-nettable Inventory” on page 262.

Include Negative. See “Include Negative Inventory” on page 262.

Items Created Before. Enter a date if you want the system to include items that were added up to this date. Use this field to exclude any items from analysis that have not existed for sufficient time to build up an issue history.

Report Consumption. Indicate whether you want to report consumption data. The system reports consumption data by inventory types, item numbers, sites, consumption dates, periods, quantities, and QOH.

No: Do not report extracted consumption data.

Yes: Report extracted consumption data.

When Retain Consumption Data in Obsolete Inventory Control is No, the system extracts data first, then reports it. If Retain Consumption Data is Yes, the system reports the previously extracted data.

Report Demand. Indicate whether you want to display item inventory type conflicts in this report. The system reports conflict data by item number, site, inventory type, line type, commodity code, ABC code, or whether the item is a purchased or manufactured item.

No: Do not report demand data.

Yes: Report demand data.

When both Add Demand and Greater of Demand are No, you cannot report demand data. If you try, an error message displays.

Report Conflicts. Indicate if you want to display item inventory type conflicts in this report.

You specify inventory types in Inventory Type Maintenance (3.5.1.1). Because of the way you group items, some items may overlap inventory types. When the system calculates obsolete inventory values, it resolves the conflict of overlapping inventory types within the same site through a course of action you specify in Obsolete Inventory Control. If you specify that the

system not analyze obsolete inventory data when it encounters conflicts, the system does not analyze the items in conflicting inventory types, but it does present conflicting inventory type data here.

No (the default): Do not report items that overlap inventory types when analyzing obsolete inventory.

Yes: Report items that overlap inventory types when analyzing obsolete inventory. Conflicting data displays in a report when the analysis completes.

See “Defining Inventory Types” on page 253.

Note You can set Conflicts Only to Yes in Item Inventory Type Report to display just conflicts before you analyze data here.

Report Coverage. Indicate whether you want to report supply coverage data. Supply coverage data includes the number of periods that the current quantity on hand supplies based on the average past usage. The system reports coverage data by item, site, inventory type, quantity on hand, total issues, and average issues.

No: Do not report extracted supply coverage data.

Yes: Report extracted supply coverage data.

Report Reserve. Indicate whether you want to report reserve data. Reserve data includes reserve values that the system calculates by applying depreciation rates to the current quantity on hand. The system reports reserve data by item, inventory type, quantity on hand, average issues, coverage periods, QOH cost, rate, and comments.

No: Do not report extracted reserve data. If Report Reserve is No and Output File Type is blank, the system does not report useful reserve data.

Yes: Report extracted reserve data.

Level 1 Field. Specify a field that acts as the first level of information for the reserve report. The system sorts data for the report based on the fields you enter here and in Level 2 Field and Level 3 Field.

Level 2 Field. Specify a field that acts as the second level of information for the reserve report. The system sorts data for the report based on the fields you enter here and in Level 1 Field and Level 3 Field.

Level 3 Field. Specify a field that acts as the third level of information for the reserve report. The system sorts data for the report based on the fields you enter here and in Level 1 Field and Level 2 Field.

Output File Type. Specify an output file type. The default is blank. A blank here creates no output file. You can specify output file formatting options in Output File Type Maintenance (3.5.1.5). See “Specifying an Output File” on page 266.

Output File Name. Specify an output file name. The default is blank. You specify the path in Path for Reserve Output in Obsolete Inventory Control (3.5.1.24). See “Setting Obsolete Inventory Controls” on page 250.

Deleting/Archiving Consumption Data

Use Consumption Delete/Archive (3.5.1.20) to delete or archive selected consumption data. You must set Delete to Yes to archive data.

If you optionally archive the consumption data by setting Archive to Yes, the system displays the archive file name it creates in Archive File. The system informs you to back up the archive file to disk.

Fig. 8.17
Consumption Delete/Archive (3.5.1.20)

Effective Date. Enter the first transaction date in a range of dates to be archived or deleted. The system converts this date to a GL period according to the GL calendar. A blank means the system deletes or archives all consumption data up to the date you specify in the To field.

Enter the last transaction date in a range of dates in the To field. A blank means the system deletes or archives all consumption data from the date you specify in Effective Date. If this field and the To field are blank, the system deletes or archives all consumption data.

Delete. Indicate if you want to delete consumption data.

No (the default): The system does not delete consumption data.

Yes: The system deletes consumption data on the dates you specify and lets you archive data.

Archive. Indicate if you want to archive consumption data. You must set Delete to Yes to archive data.

No (the default): The system does not create an archive file of consumption data.

Yes: The system creates an archive file. Archive File displays the archive file name the system creates. The system informs you to back up the archive file to disk.

Viewing Obsolete Inventory Analysis Data

Obsolete inventory analysis enhancements let you build reports displaying obsolete inventory analysis data. The following sections describe reports included in obsolete inventory analysis enhancements and includes example reports.

Table 8.5
 Obsolete Inventory Analysis Reports

Report	Comments
Consumption Report (3.5.1.19)	<p>Displays consumption data by individual or a range of inventory types, item numbers, sites, consumption dates, or periods.</p> <p>You can also display consumption data by setting Report Consumption to Yes and ABC Analysis to No in Obsolete Inventory Analysis (3.5.1.9). If you do, the system reports the same data ranges for which it is analyzing inventory.</p>
Demand Report	<p>Displays demand data when you run Obsolete Inventory Analysis by:</p> <ul style="list-style-type: none"> • Setting either Add Demand or Greater of Demand to Yes • Setting Report Demand to Yes <p>If you run the report before the end of the GL period, the system displays a message, warning you that it extracted data for a partial period only. The system extracts demand data only when you run the report. It is not stored in database table.</p>
Conflict Report	<p>Displays conflicting inventory type data that can result because of the way you group items in Inventory Type Maintenance (3.5.1.1). Obsolete Inventory Analysis resolves the conflict of overlapping inventory types through actions you specify in Obsolete Inventory Control (3.5.1.24). You have two methods to display conflicting inventory type data:</p> <ul style="list-style-type: none"> • Set Report Conflicts to Yes in Obsolete Inventory Analysis. • Run Item Inventory Type Report (3.5.1.14). <p>In Item Inventory Type Report, the system reports items that overlap inventory types by marking the items with an asterisk (*) in a Conflict column in the report. You can set Conflicts Only to Yes in Item Inventory Type Report to display just items in conflicting inventory types.</p>
Coverage Report	<p>Obsolete Inventory Analysis calculates the number of periods of supply coverage. You can optionally display coverage data when the analysis is complete.</p>
Reserve Report	<p>Obsolete Inventory Analysis calculates the value of obsolete inventory reserve. You can optionally display reserve data when the analysis is complete. You decide which fields display at which levels in the report in Obsolete Inventory Analysis.</p>
Inventory Type Item Report (3.5.1.13)	<p>Displays items, including the inventory type IDs that match the items.</p> <p>If the system finds multiple matching inventory types, it displays them alphabetically. If you set Conflicting Inventory Types to BESTFIT in Obsolete Inventory Control, the system displays them in best-fit sequence and all items indicate a conflicting inventory type by an asterisk (*) under Conflict.</p> <p>Specify a range of inventory types, item numbers, or sites. Specify Yes or No to display items or field ranges in the report.</p>
Item Inventory Type Report (3.5.1.14)	<p>Displays inventory types and optionally display items within each inventory type. You can run this report before you run the Obsolete Inventory Analysis program. This lets you resolve conflicts and reassign items in overlapping inventory types before you analyze data.</p> <p>Specify a range of inventory types, item numbers, or sites. Specify Yes or No to display inventory type conflicts only or field ranges in the report</p>

Creating Inventory Reports

Use the reports on Inventory Detail (3.1) and Inventory Reports Menus (3.6) to check inventory statuses and values (current and GL).

Detail Allocation Inventory Report

Use Detail Allocation Inventory Report (3.1.5 or 2.1.9.6) to review how much detail-allocated inventory exists in a site or location for ranges of items, sites, locations, addresses, or inventory status codes. The summary report lists detail-allocated inventory totals by item or site. The detail report also lists specific lot, serial, and reference, information. You can optionally display sales order information on the detail report.

Stock Status Report

Use Stock Status Report (3.6.1) to review an item's total quantity on hand and quantity on order by site. The report gives information for each location containing the item. Location information shows each item's lot/serial number, reference number, and quantity on hand.

Reorder Report

Use Reorder Report (3.6.2) to see if an item is below the reorder point or safety stock. The report shows all locations containing the item and indicates those below the reorder point or safety stock. Also shown are any open orders for the item, the quantity open, and the supplier name.

Item ABC Status Report/Update

Use Item ABC Status Report/Update (3.6.3) by product line or site to calculate item ABC class codes. Calculations can be made by a combination of either sales or issues and cost or gross profit. Three fields can be updated for existing records:

- ABC class codes
- Item average usage
- Cycle count intervals

You can also change default ABC classification percentages. Depending on the option selected, the report lists items in descending sales or issue value, and shows an item's old and new ABC classifications. When you update the ABC class and item-site inventory records do not exist in Item-Site Inventory Data Maintenance (1.4.16), the system creates new records.

Inventory Detail Report

Use Inventory Detail Report (3.6.5) to see inventory availability status in detail or summary format. The summary report lists item inventory information at the site level:

- Quantity on hand
- Available quantity on hand
- Non-nettable quantity
- Quantity required

- Quantity allocated
- Quantity on order

The detail report adds detailed information by location within the site:

- Quantity on hand
- Quantity allocated
- Item characteristics such as expire date, grade, assay %, and inventory status

If you are generating a detail report, you can also view subtotals by item and location.

Inventory Detail by Location

Use Inventory Detail by Location (3.6.6) to see item inventory information by location:

- Quantity on hand
- Item characteristics such as expire date, grade, assay %, and inventory status

Current Surplus Inventory Report

Use Current Surplus Inventory Report (3.6.8) to review current surplus quantities and GL value by product line within a site. The system determines surplus by the absence of issue activity based on a user-specified issue date.

Reports can be generated in detail or summary format. The summary report shows information for product lines within a site. The detail report shows item information for each product line in the site. In both reports, totals are shown for expired value and value on hand, by site and for the report.

Projected Surplus Inventory

Use Projected Surplus Inventory (3.6.9) to review projected surplus inventory for a future effective date based either on MRP requirements or average use. Choose either current cost or GL cost for surplus cost computations. For these calculations, the expiration date for items is the system date, not the effective date. You can include firm planned orders or MRP planned orders on the report, which are marked On Order.

Reports can be generated in summary or detail format. The summary shows the total expired value and ending value for each product line within a site. The detail report shows item information within each product line in the site, total expired value, ending value, quantity on order, expired quantity, and ending quantity.

Inventory Valuation Reports

Inventory valuation reports display the inventory value of quantities on hand by product line or location. Some reports show inventory values as of a specified date. You can include negative inventory in each report, and on some you can select whether items with an initial GL value of zero are valued using this initial zero or the first available cost.

- Use Inventory Valuation Report (3.6.13) to review the value of inventory in a site by product line or item number. The total value of each item is shown, with a grand total for the product line.
- Use Inventory Valuation by Location (3.6.14) to review the value of inventory in each location of a site by product line or item number. The total value of each location is shown, with a grand total for the site.
- Use Inventory Valuation as of Date (3.6.15) to review the value of all items in a product line as of a user-specified date. The total inventory in each site is shown, with a grand total for the product line.
- Use Inventory Valuation as of by Loc (3.6.16) to review the value of inventory in each location of a site on a user-specified date. The total value of each location is shown, with a grand total for the site. To have the system consider locations that have had detail records deleted since the effective date, set Recalculate Deleted Locations to Yes.

Stock Journal

In many countries, businesses are required to validate inventory movement over a range of dates to verify that no fraud occurred in inventory accounting.

Use Stock Journal (3.6.18) to validate the movement in inventory balances over a range of dates. The report shows all inventory transactions, together with beginning and ending stock balances.

In addition, the report contains the following information for each inventory movement:

- Shipper number
- Invoice number when appropriate
- Order number when appropriate
- Quantity received or issued
- Transaction date
- Effective date
- Customer or supplier address code
- Internal transaction number for tracking purposes
- Transaction type

Device History Record Report

Use Device History Record Report (3.6.20) to display the production history of a finished device—if it is a serialized end item—or an end lot of finished devices. Multiple levels of component history can be included.

The output of this report can be used by medical device manufacturers to help satisfy the reporting requirements outlined in Food and Drug Administration 21 CFR Part 820, that require the following information:

- The dates of manufacture
- The quantity manufactured
- The quantity released for distribution
- Any device identifications and control numbers used

The report includes the components used, their lot or serial numbers, the date of issue, the ID of the user who performed the issue transaction, and the transaction number. In addition the labor recorded is displayed with the user ID of the user who recorded the labor and the transaction ID.

Item Scrap Report

Use Item Scrap Report (3.6.21) to review the operations impact of scrap transactions on ranges of items, sites, orders, reason codes, effective dates, or authorization document numbers. The report can be sorted by combinations of the data selection criteria. For the selected data, the report displays quantity and extended currency (quantity * cost) totals and subtotals for each sort category.

Note You can view similar scrap information in Inventory Scrap Transaction Browse (3.6.23).

Financial Scrap Report

Use Financial Scrap Report (3.6.22) to review the cost impact of scrap transactions on ranges of items, sites, reason codes, effective dates, debit accounts, sub-accounts, cost centers, or authorization document numbers. The report can be sorted by combinations of the data selection criteria. For the selected data, the report displays quantity and extended currency (quantity * cost) totals and subtotals for each sort category. The detail version of the report displays the details of each included transaction; the summary version does not include the details.

Note In QAD .NET UI, you can view similar information using enhanced reports: Inventory Scrap Trans Acct Rpt (3.6.46) shows detailed information; Inventory Scrap Acct Rpt (3.6.47) is formatted to show summary information.

Checking Inventory Availability

Use the following programs to quickly check inventory locations:

- Use Inventory Detail by Item Browse (3.2) to see an item's total nettable (available to allocate) and non-nettable inventory, sorted by site. Item location information is also shown.
- Use Inventory Detail by Site Browse (3.3) to see the total quantities on hand by site, sorted by item number. Item location information is also shown.
- Use Stock Availability Browse (3.17) to review stock availability in a single site or in all sites.
- Use Allocated Inventory Inquiry (3.18) to review total item quantities on hand for a site. Allocated and unallocated quantities for an item are also shown. Allocated quantity detail information includes:
 - Type of order (sales order or work order)

- Order number
- Quantity allocated
- If it is a detail (Picked) or a general (Qty Alloc) allocation
- Use Unallocated Inventory Inquiry (3.19) to review non-detail-allocated inventory for a specified item, by site and location. Site information shows quantity on hand and quantity allocated. Location information shows unallocated quantity for the location. Expiration date and grade are also shown. Unallocated quantity can include quantities reserved by general allocations.

Physical Inventory

This chapter explains how to determine how much physical inventory is actually on hand.

Introduction to Physical Inventory 278

Introduces physical inventory concepts and features.

Deleting/Archiving Old Tags 278

Discusses how to delete and archive old tags.

Freezing Inventory Balances 278

Explains how to freeze inventory balances.

Creating/Printing Tags 279

Outlines how to create and print tags.

Entering Initial Tag Counts 279

Explains how to enter initial tag counts.

Reviewing Results 280

Covers how to review results.

Zeroing/Voiding Unused Tags 280

Discusses how to zero or void unused tags.

Updating Inventory Balances 280

Discusses how to update inventory balances.

Introduction to Physical Inventory

Physical Inventory enables you to count and compare actual, on-hand inventory balances with on-hand quantities recorded in the system. This can also be done with cycle counting.

See “Performing Cycle Counts” on page 246 for details.

To perform a physical inventory count, first determine the items you want to count and the count frequency. Each item to be counted must have a system-generated count tag, used to record item count information.

The steps for conducting a physical inventory are:

- 1 Delete the tags from the previous physical inventory.
- 2 Freeze inventory balances.
- 3 Create and print tags.
- 4 Enter initial tag counts.
- 5 Review results and enter recounts if necessary.
- 6 Void/zero count unused tags.
- 7 Update inventory balances.

Deleting/Archiving Old Tags

Before creating new tags for an inventory count, delete tags from the last count using Tag Delete/Archive (3.16.23). This program:

- Deletes specified tags.
- Archives deleted tag information.
- Generates a report showing all deleted tags.

Typically, you delete only tags that have been posted using Inventory Balance Update (3.16.21).

Delete. Enter No to review tags selected for deletion without actually deleting them. The system generates a report showing tag numbers selected for deletion and whether they have been posted or voided. Enter Yes to actually delete selected tags.

Archive. Enter Yes to have deleted tag information archived.

Archive File. Enter the file to which you want the system to archive deleted tag information.

Freezing Inventory Balances

After deleting old tags, freeze the inventory to be counted using Inventory Balance Freeze (3.16.4). The system records the current quantity on hand for all selected inventory and uses this record to carry out the inventory count.

Note Freezing inventory does not prevent the system from processing regular inventory transactions. Changes to inventory during a count must be included for the count to be accurate.

Select inventory to be frozen using one or more of the following criteria:

- Site
- Location
- Product Line
- Item Number
- ABC Class

Specify a single selection (site 10000) or a range (site 10000 to 20000). To select all items, leave the range blank.

Creating/Printing Tags

Each item to be counted needs a tag showing the item's site, location, and item number. Then record count information on the tag. In the event of a recount, recount information goes on the same tag.

There are two types of count tags: item and bulk. Use Item Tag Create (3.16.1) to create tags for selected items. You can select items by item number, site, product line, or ABC class. Enter no selection criteria to create tags for all items in your system.

Use Bulk Tag Create (3.16.2) to create bulk tags. Bulk tags are the same as item tags, except that the item information on bulk tags is blank. Use bulk tags to count items that do not have item tags.

To find out how many bulk tags you need, use any one of the following:

- Tag Inquiry (3.16.8)
- Tag Report (3.16.13)
- Uncounted Tag Report/Update (3.16.15)

After creating count tags, use Tag Print (3.16.6) to print both types of tags. You can print tags on most standard-size forms. Default forms are set to print on 3 x 5 inch card stock. You can optionally print the tag number in bar code format if your system is formatted to do so.

In the event of errors, delete incorrect tags using Tag Delete/Archive (3.16.23), then recreate and print new ones.

Note Before deleting bulk tags, void the tags using Tag Void Status Update (3.16.7).

Entering Initial Tag Counts

After counting tagged items, enter the count in the system using Tag Count Entry (3.16.11). Tag Count Entry accepts all quantities, even those that are out of tolerance. Enter any changes resulting from post-freeze inventory transactions. At this point, only the frozen inventory quantities are updated.

Example The frozen quantity of Item Z is 100. After inventory freeze, 50 units of Item Z are issued. The inventory count shows 47 units of Item Z on hand. Enter a count quantity of 97 (50 + 47).

Fig. 9.1
Tag Count Entry (3.16.11)

The screenshot shows a window titled "Tag Count Entry" with a menu bar containing "Go To" and "ACTIONS". The main area contains the following fields:

- Tag Number: 1
- Site: 10000 NJ Plant
- Location:
- Item Number: 5700 UM: EA ABC Class:
- Description:
- Lot/Serial: Ref:
- Quantity Counted: 150.0 Qty Recounted:
- Count UM: EA Recount UM:
- Count Conv: 1.0000 Recount Conv:
- Counted By: usr Recounted By:
- Date Counted: 3/13/2007 Date Recounted:
- Remarks:

Reviewing Results

After entering count results, review the results using Inventory Variance Report (3.16.18). Look for out-of-tolerance quantities or other problems. You can print the report by variance amount.

Recount out-of-tolerance items. Use Tag Recount Entry (3.16.12) to enter recount information on the same item tags or bulk tags used for the initial count.

Zeroing/Voiding Unused Tags

Before a count is complete, all tags must be either counted or voided. Use Uncounted Tag Report/Update (3.16.15) to ensure that all item and bulk tags are accounted for. This report shows only tags that have not been voided or set to zero.

Set Tag Count to Zero. Some tags may be left over, either because items were not found or were counted using bulk tags. These cannot be voided. Set this field to Yes for leftover tags.

Use Tag Void Status Update (3.16.7) to declare unused bulk tags void. Only voided bulk tags can be deleted.

Updating Inventory Balances

When all tags are accounted for and count results are satisfactory, use Inventory Balance Update (3.16.21) to update quantity-on-hand balances. The system changes each item's quantity on hand to the difference between the frozen quantity on hand and the count quantity.

Example The frozen quantity of Item Z is 100. The count quantity (50 issued, 47 counted) is 97. The update quantity is -3. The updated quantity on hand for Item Z is 97.

Enhanced Reports for .NET UI

This chapter discusses enhanced functionality that is available to QAD .NET UI users of reports, browses, and inquiries in the master data modules.

Introduction 282

Introduces the concept of enhanced reports and describes how to access them.

Using Enhanced Reports 282

Summarizes the steps required to set up filters and select the output medium for the report.

List of Modified Reports, Browses, and Inquiries 284

Includes a cross-reference between standard programs and their equivalent enhanced versions.

Introduction

QAD has rewritten numerous reports throughout the master data modules to take advantage of the enhanced functionality available through Reporting Framework. These reports provide a significantly improved reporting capability to users of the QAD .NET UI.

For information on the tools used to write the enhanced reports, see *User Guide: QAD Reporting Framework*.

In some cases, reports have been redesigned as browses (or browses as reports) or broken into multiple menu items, as shown in Table 10.1. For example, Financial Scrap Report is now available as two separate enhanced .NET UI reports to provide specific output formats for summary and detailed layouts.

Note The standard versions of the programs are still available in their original menu locations. You can use them in both character UI and .NET UI.

You can access the new programs in several ways:

- By entering the title in the menu search field. For reports, the search result lists two occurrences. Menu icons differentiate the enhanced reports from the standard versions.

Fig. 10.1
Report Icons in .NET UI

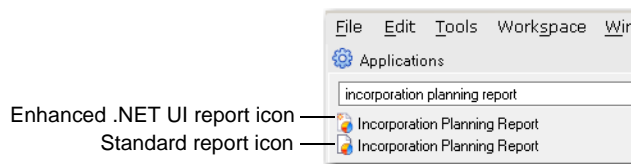

- By entering the enhanced report menu number in the menu search field (Table 10.1). The menu positions are always 25 or greater, so the .NET UI-only reports do not display on the character UI menus.

Note You cannot access a new report by entering a Progress program name.

- By navigating in the menu tree to the related functionality area. The enhanced reports are in the same directories as their standard report counterparts.

Using Enhanced Reports

This topic includes a brief overview of the basic steps used to generate a report. For more information on filters, output options, and so on, see *User Guide: QAD Reporting Framework*.

Running a Report

- 1 Access the report. The Report Filter screen is displayed in the application area.

Fig. 10.2
Report Filter

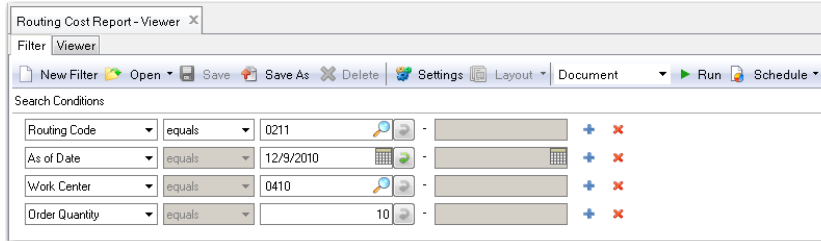

- 2 By default, a report displays all the records available in the source data. However, you may want to retrieve just a certain range of records in the report; for example, routing costs for an item at one specific work center. You do this by setting search conditions to filter data in the report for one or more of the available criteria.
 - a Configurable filter capabilities let you create both simple and complex queries. Choose a search operator from the drop-down list: equals, not equals, and so on.
 - b If you choose the Range operator, enter a beginning value of the range in the first search box. Optionally, enter an ending value of the range in the second search box.
 - c To refine your search further, click the plus (+) icon to add another search row. You can add as many rows as needed, each with different search values and operators. When you specify several criteria, note that multiple criteria for the same field are treated as a logical AND condition.
 - d To remove a search criteria row, click on the delete (X) icon.
 - e Optionally, click Save As to save the new search conditions as a filter for future reuse.
- 3 On the toolbar, select a layout from the Layout pull-down list. (This feature is available only for a report resource with multiple report definitions.) The default layout is listed in bold text.
- 4 On the toolbar, select an output format from the pull-down list before the Run button. You can choose from several output formats when the report is run:
 - Document — The report is displayed in the Report Viewer window.
 - PDF — The report is rendered as a PDF file. You can save the file and open it in the Report Viewer window.
 - PDF Read-only — The report is rendered as a read-only PDF file. It has a random password that prevents tampering with the document.
 - TIFF — The report is rendered as a Tagged Image File Format (TIFF) file.
 - RTF — The report is rendered as a Rich Text Format (RTF) file. You can open this file in Microsoft Word and save it in .doc format.
 - Excel — The report is rendered as a Microsoft Excel (.xls) file. You can save the file and open it in the Report Viewer window.
 - Plain Text — The report is rendered as a plain text (.txt) file.

- 5 On the toolbar, click Run. A report generation progress bar appears. When report generation is complete, the report is displayed in the Report Viewer window directly or opened as a PDF or Excel file depending on which output format you selected. For some formats, you can click Save to create a file of the specified type in a directory on your file system.

Running Reports Directly From Browsers

You can directly run reports from browsers by selecting Report from the Action menu in the browse screen. The sorting, grouping, and search criteria in the browse are all carried over to the report, which uses the browse as its data source. You can further filter data in the report by defining new search criteria in the Filter screen. Just as in reports, click the plus (+) icon to add search rows.

List of Modified Reports, Browsers, and Inquiries

Table 10.1
Reporting Updates for Master Data Functions

Standard Menu Number	Standard Program Title	Standard Program	Enhanced Menu Number	Enhanced Program Title
1.2.19	Sales Account Report	ppplsrp.p	1.2.18	Sales Account Browse
1.22.14	Lot Group Inquiry	clgliq.p	1.22.14	Lot Group Browse
1.22.16.14	General License Report	clglirp.p	1.22.16.15	General License Browse
1.22.16.2	Controlled Authority Inquiry	clctaiq.p	1.22.16.2	Controlled Authority Browse
1.9.7.3	Incorporation Planning Report	ecinplan.p	1.9.7.27	Incorporation Planning Report
3.21.12	Daybook Trans Accounting Report	icdyacrp.p	3.21.36	Daybook Trans Accounting Report
3.21.1	Transactions Detail Inquiry	ictriq.p	3.21.25	Transactions Detail Report
3.21.13	Transactions by Order Report	ictrrp02.p	3.21.4	Transactions by Order Browse
3.21.16	Transactions Accounting Report	ictrrp03.p	3.21.40	Transactions Accounting Report
3.6.23	Scrap Transaction Browse	icbr027.p	3.6.23	Inventory Scrap Trans Browse
3.6.21	Item Scrap Report	icscrprp.p	3.6.23	Inventory Scrap Trans Browse
3.6.22	Financial Scrap Report	icscfnrp.p	3.6.46	Inventory Scrap Trans Acct Rpt (Formatted with Detail Layout)
			3.6.47	Inventory Scrap Acct Rpt (Formatted with Summary Layout)

Index

Symbols

.NET UI reports 281

Numerics

1.1.1 51
1.1.13 42
1.1.18 46, 48
1.2.1 37
1.2.4 38
1.2.13 37
1.2.22 38
1.2.23 39
1.3.1 158
1.4.1 5, 67, 158
1.4.3 104, 121, 122
1.4.5 5, 9, 104, 122, 158
1.4.7 5, 104, 122
1.4.9 5, 104
1.4.12 158
1.4.16 6, 104, 122
1.4.17 6, 122
1.4.18 6, 14, 122
1.5.9 9
1.5.12 6
1.8.1 62
1.8.4 63
1.8.7 64
1.8.13 65
1.8.17 62
1.8.19 64
1.8.20 65
1.9.1.1 111
1.9.1.3 112
1.9.1.5 114
1.9.1.7 116
1.9.1.9 117, 119
1.9.2.1 118
1.9.2.4 107
1.9.2.8 129
1.9.2.13 118
1.9.2.16 107, 130
1.9.6.1 107, 110, 131
1.9.6.2 130
1.9.6.13 132
1.9.7.1 108, 117, 119, 133
1.9.7.3 108, 133
1.9.7.4 108, 134, 136
1.9.7.5 108, 135
1.9.7.13 135
1.9.9.1 129
1.9.9.6 109
1.9.11 129
1.9.13 119, 136
1.9.14 136
1.9.24 109
1.10.1.1 67, 73
1.10.1.2 77
1.10.1.3 77
1.10.1.5 77
1.10.1.6 77
1.10.1.8 77
1.10.1.15 80
1.10.1.17 80, 83
1.10.1.18 83
1.10.1.24 59
1.10.2 57
1.10.2.1 57
1.10.2.2 57
1.10.2.3 57
1.10.2.4 57
1.10.2.5 57
1.10.2.6 57, 92
1.10.3 57
1.10.3.1 57
1.10.3.2 57
1.10.3.3 57
1.10.3.4 57
1.10.3.5 57
1.10.24 99
1.12 6
1.16 15, 22
1.19 15
1.22.1 157, 161
1.22.4 145, 146
1.22.9 151
1.22.13 158
1.22.16.1 163
1.22.16.4 164
1.22.16.7 164
1.22.16.10 164
1.22.16.13 165
1.22.16.16 166
1.22.19 151, 152
1.22.22 156, 157
1.22.23 153
1.22.24 141
1.23.1 17
1.23.5 19
1.23.7 19
1.23.23 16
2.1.1 175
2.1.9.1 48, 179

2.1.9.2	49	3.13.2	247, 248
2.1.9.3	49	3.13.3	248
2.1.9.5	179	3.16.2	279
2.1.9.6	179	3.16.4	278
2.3.1	179	3.16.6	279
2.3.7	180	3.16.7	280
2.5.1	173	3.16.8	279
2.5.16	174	3.16.12	280
2.12	172	3.16.13	279
2.14.1	181	3.16.15	279, 280
2.15.1	206	3.16.18	280
2.15.4	214	3.16.21	278, 280
2.15.7	229	3.16.23	278, 279
2.15.13	208	3.17	275
2.15.16	208	3.18	275
2.15.19	208	3.19	276
2.15.24	204	3.21	245
2.16.1	182	3.21.1	151, 245
2.17.1	183	3.21.2	245
2.19.13	184	3.21.4	245
2.20.1	186	3.21.13	245
2.20.4	187	3.21.14	245
2.20.7	187	3.21.16	245
2.20.10	188	3.21.19	245
2.23.1	193	3.21.23	245
2.23.2	193	3.21.25	245
2.23.4	193	3.22.1	151, 246
2.23.7	193	3.22.2	246
3.1.5	272	3.22.3	151, 246
3.3	275	3.22.4	151, 246
3.4.1	239	3.23	47
3.4.2	239	3.24	9, 234
3.4.3	239	5.13.1	159
3.4.4	240	5.13.19	220
3.5.1.1	255	7.1.1	83, 85
3.5.1.3	256	7.1.6	11
3.5.1.5	258	7.1.11	81, 83
3.5.1.7	260	7.5.1	29
3.5.1.9	262	7.5.2	29
3.5.1.13	271	7.15.7	84
3.5.1.14	251, 271	11.7.1.1	86
3.5.1.19	271	11.7.3.13	159
3.5.1.20	269	13.5	104
3.5.1.24	250	13.13.3	109
3.6.1	272	13.13.22	109
3.6.2	272	14.22	109
3.6.3	9, 272	15.5	104
3.6.5	272	15.22	109
3.6.6	273	16.3.1	151
3.6.8	273	16.3.2	151
3.6.9	273	16.3.3	151
3.6.13	274	16.3.6	151
3.6.14	274	16.6	151
3.6.15	274	16.7	151
3.6.16	274	16.9	151
3.6.18	274	16.11	159
3.6.20	274	16.12	159
3.7	240	16.13.1	11
3.8	240	16.19	159
3.9	240	18.14	159
3.10	240	18.22.13	159
3.11	240	18.22.19	159
3.12	240	19.1.13	104
3.13.1	247	19.1.22	109

35.4.1. 32
 36.2.17 115
 36.2.21.1 204
 36.4.2 17
 36.9.10 40
 36.13.2 109
 36.14.1 109
 36.14.3 109
 36.17.6 98

A

ABC analysis data 251
 ABC class codes 9, 247
 ABC Status Report/Update 9
 accounts
 expensed item receipts 180
 inventory 37
 logistics 202
 PO receipts 180
 product line 36
 accrual
 logistics charges 196
 price list 76
 action status, sales order repricing 82
 activating compliance 142
 additive discounts 59
 addresses 170–194
 bill-to 173
 carrier 183
 company 172
 deleting 173
 list type 171
 printing on forms 173
 salesperson 174
 ship-to 173
 supplier 179
 advanced repetitive
 transactions, inventory attributes 144, 147
 advanced ship notices 32
 allocate single lot 11
 Allocated Inventory Inquiry 275
 alternate product line accounts 37
 amount type
 list/discount table pricing 91
 Analysis Code Copy 65
 Analysis Code Detail Build 64
 Analysis Code Detail Inquiry 65
 Analysis Code Detail Maintenance 65
 Analysis Code Link Maintenance 64
 Analysis Code Maintenance 62
 Analysis Code Report 62
 Analysis Code Selection Maintenance 63
 Analysis Code Where-Used Inquiry 65
 analysis codes 60–66
 automatic build 64
 automatic regeneration 59
 building 64
 child 64
 combining into groups 63
 conditions 63
 copying 65
 customer conditions 63
 item conditions 63
 linking 63

 parent codes 64
 planning 58
 rules 64
 setting up 60
 Apportion Method field 207
 apportioning logistics charges 197
 approval
 group for PCC 115
 product change order 114, 131
 Approval Browse 130
 archive/delete consumption data 269
 assay%
 and orders 145
 changing 151
 definition 146
 attributes. *See* regulatory attributes
 authority codes 163
 auto lot numbering 158
 assigning lot groups 158
 assigning lot numbers 159
 effects of 158
 gaps in sequence of 158
 lot level 155
 automatic
 analysis code regeneration 59
 item replacement 16
 locations 48
 lot numbers 10
 average interval 10

B

Backflush Transaction 159
 batch numbers
 assigning to work orders 150
 benefits 141
 reporting, traceability 150
 workflow 150
 Batchload Transfer With Lot/Serial Change 240
 best pricing 58–86
 analysis codes 60
 calculating 70
 combining discounts 68
 configured items 69
 control defaults 59
 planning 58
 price lists 73
 reports 79
 repricing 81–84
 Blanket Order Maintenance 216
 Blanket Order Release to PO 216
 blocked codes 189
 Blocked Customer Maintenance 193
 Blocked Supplier Maintenance 193
 Blocked Transaction Maintenance 193
 Blocked Transaction Report 193
 break categories 58, 66, 69
 Build PO From Requisition 216
 Bulk Tag Create 279
 burden, variable overhead 14

C

calculating demand 265
 calculations for pricing 98
 Carrier Maintenance 183

- cascading discounts 59
- categories, break 58, 66, 67, 69
- Change Over Qty field 24
- CIM interface, inventory transfer 240
- classes
 - ABC analysis data 251
 - freight 187
- classification, changing for price lists 99
- cloning
 - formulas 127
 - processes 128
 - product structures 123
 - routings and operations 126
- closing
 - PCO to PCO 120
 - PCR/PCO 136
- combinable discounts 68
- comma-separated values 259
- Comments field 25
- commissions 173
- Company Address Maintenance 172
- company addresses
 - deleting 173
 - setup 172
- compliance. *See* regulatory attributes
- component issue control
 - benefits 141
 - restrictions 162
- configured items, pricing 69, 75
- conflicting classifications 251
- conflicting inventory types
 - reporting 271
 - reporting during analysis 268
 - system action 251
- consignment records
 - internal part change over
 - consignment records 33
- consumption data
 - deleting 269
 - filtering 252
 - last extraction date 252
 - reporting 271
 - retaining 252
 - transactions 252
 - update from initial build 261
 - vs. demand 265
 - with demand 265
- Consumption Delete/Archive 269
- contract lines, searching 21
- control program
 - Inventory 234
 - Item Replacement 16
 - Logistics Accounting 204
 - Pricing 59
 - Regulatory Attributes 141
- Control Tables Report 98
- Controlled Authority Maintenance 163
- Controlled Customer Maintenance 164
- Controlled Item Maintenance 164
- Controlled Site Maintenance 164
- controlled substances 162–167
 - benefits 141
 - workflow 163
- conversion, PCR to PCO 121
- converter programs
 - icobrpd.p 259
 - icobrpe.p 259
- cooperative marketing 59
- co-products/by-products, modifying receipts 142
- copying
 - analysis codes 65
 - PCOs from PCRs/PCOs 120
 - PCOs to PCR/PCO 120
 - price lists, best pricing 77
 - processes in PCR/PCO 128
 - product line accounts 38
- copying price lists 93
- Cost Element Maintenance
 - logistics charges 213
- Country Code Browse 181
- Country Code Data Maintenance 181
- Country Code Report 181
- country codes
 - alternate 181
 - DEA country 182
 - EU country 181
 - GATT country 182
 - groups 182
 - NAFTA 182
 - NAFTA country 182
 - operational data 181
 - regulatory attributes 163
 - type 182
- creating supplier price lists 89
- creating the master lines 27
- credit limit checking in repricing 82
- cross-sell items 15, 19
- CSV. *See* comma-separated values
- cumulative end effective quantity 22
- Cumulative End Effective Quantity field 28
- currency, price lists 73
- Current Surplus Inventory Report 273
- Cust Sched Price List Browse 57
- Cust Sched/RMA Rcpt Pricing Menu 57
- Cust Schedule Price List by Item 57
- Cust Schedule Price List Copy 57
- Cust Schedule Price List Maintenance 57
- Cust Schedule Price List Report 57
- Customer Data Maintenance 175
- customer demand 20
- Customer Item Maintenance 15
 - new features 22
- customer item replacement 21
- customer items 15
- customer items in customer scheduled orders 26
- Customer Orders by Price List Inquiry 80
- Customer Plan Schedule Main 29
- customer scheduled orders
 - contract lines 21
 - cumulative end effective quantity 22
 - customer items 26
 - item replacements 26
 - new features 21
- Customer Ship Schedule Maint 29
- customers
 - analysis codes regeneration 59
 - blocking transactions 189
 - credit data 177

- freight data 178
- operational data 174
- reserved locations for 178
- Cycle Count Results Entry 247, 248
- Cycle Count Results Report 248
- Cycle Count Worksheet Print 247
- cycle counting 52, 247
 - interval 10

D

- D type price list 88
- data
 - initial vs. incremental extraction 260, 261
 - retaining consumption 252
- date
 - PCO effective 134
 - pricing effective 60
- dates on price lists 87
- deactivating
 - formulas 127
 - processes 128
 - product structures 125
 - routings and operations 127
- default
 - converter program 259
 - filter program 252
 - inventory status 147
- default price lists 89
- defining change over quantity 24
- delete/archive
 - consumption data 269
 - inventory tags 278
 - lot masters 153
- Delivery Transit Time Maintenance 182
- demand, calculating 265
- Depreciation Rate Maintenance 256
- depreciation rates
 - example 256
 - for zero demand/consumption 256
 - specifying 256
 - specifying percentages 257
 - when to define 249
- Detail Allocation Inventory Inquiry 179
- Detail Allocation Inventory Report 179, 272
- Detail Approval Maintenance 132
- Device History Record Report 274
- Direct Item Data Access 122
- Direct Item Inventory Data Access 122
- Direct Item Planning Access 122
- Direct Item Site Cost Access 122
- Direct Item Site Inventory Data Access 122
- Direct Item Site Planning Access 122
- discount sequence 75
- discount tables
 - required for purchasing 97
 - required for scheduled orders 97
 - requiring 98
- discount types, best pricing
 - accrual 68
 - credit terms 68
 - discount % 67
 - discount amt 67
 - freight list 68
 - freight terms 68

- list price 67
- markup 68
- net price 68

- discounts 59
 - additive example 71
 - base 68
 - base-combinable 68
 - cascading example 72
 - combinable 68
 - combination type 59
 - exclusive 68
 - pricing 80
 - quantity 81
 - sequence order 71
 - volume 59, 81
 - volume discounts 59
- Discrete Discount Table Req field 97
- displaying price list data 99
- distribution group 117
- domains, site links 41

E

- ECO. *See* engineering change order (ECO)
- effective dates
 - processing orders 31
- effective dates, setting for PCOs 134
- e-mail, during PCC routing 115
- Enable PCC Formula Maintenance 109
- Enable PCC Item Spec Maintenance 109
- Enable PCC Routing Maintenance 109
- Enable PCC Structure Maintenance 109
- end effective quantity 22
- end effective warnings 28
- engineering change order (ECO)
 - printing 109
 - turning off functionality 109
- enhanced reports 281
- entities, site links 43
- European Union (EU), country codes 181
- Expensed Item Receipts accounts 180
- expensed memo type 11
- expiration dates, copying price lists 94
- expire date
 - changing 151
 - defined 146
 - inventory 145
- expired inventory
 - management 153
 - transactions 161
- Export Control Classification Numbers 162
- export, PCR/PCO 136
- Extract Consumption 260
- extracting data
 - initial vs. incremental 260, 261
 - length of time to extract 260
 - overview 260
 - quantity on hand 252
 - transactions 252

F

- field value ranges 250, 254
- fields, analysis output 253
- filtering consumption data 252
- fixed price, sales orders 81

- Formula Maintenance 104
- formulas, assay% and grade 146
- freezing inventory balances 278
- freight charges 185–189
 - freight class 187
 - freight lists 186
 - freight terms 188
 - freight zones 187
 - logistics 226
- Freight Charges Maintenance 188
- Freight Class Maintenance 187
- Freight List Maintenance 186
- freight terms 188
- Freight Terms Maintenance
 - logistics charges 223
- Freight Zone Maintenance 187

G

- General License Maintenance 165
- generating price lists 92
- geographical area 59
- GL calendar 252
- GL periods 252, 263
- Global Tax Management (GTM)
 - addresses 173
 - country code data 181
 - logistics charges 210
- goods-in-transit, logistics charges for 219
- grade
 - and orders 145
 - changing 151
 - defined 146
- Group Maintenance 111
- groups
 - PCC 111
 - adding users 113
 - approval 115
 - replacing users 113, 114
 - product change control (PCC)
 - distribution 117

H

- Harmonized Tariff Codes 162
- Health Industry Numbers 162

I

- icobexb.p filter program 252
- icobrdp.p converter program 259
- icobrpe.p converter program 259
- Implementation (PCO) 135
- import, PCR/PCO 136
- Inbound Account Maintenance 208
- Include field 25
- Incorporation (PCO) 108, 135
- Incorporation Planning Report 108, 133
- Incorporation Selection 108, 134, 136
- Individual License Maintenance 166
- initializing PCOs 109
- inquiries
 - memory considerations 246
 - workfiles and 246
- internal items
 - cross-reference to customer item 22
- internal part change over

- ASNs 32
- EDI 33
- invoices 33
- picklists 32
- processing orders 31
- setting up 22
- shipping 32
- in-transit goods, logistics charges for 219
- inventory 233–276
 - accurate balances 52
 - analyzing obsolete items 248–271
 - availability 50
 - checking availability 275
 - data 5, 8
 - detail records 238
 - impact of PCO 133
 - including items in analysis 268
 - issue restrictions 50
 - location 46
 - negative balances 51
 - nettable 50
 - non-nettable 268
 - not available 50
 - overissue 52
 - picking 234
 - sites 40
 - status codes 50
 - supplier-consigned 267
 - total 238
 - transactions 51
 - updating balances 280
 - zero consumption/demand 257
- Inventory Account Maintenance 37
- inventory attributes 144
 - changing 151
 - field security 151
 - regulatory attributes 140, 143
 - search order 148
 - status 145
- Inventory Balance Freeze 278
- Inventory Balance Update 278, 280
- inventory codes
 - ABC Class 9
 - allocate single lot 11
 - automatic lot numbers 10
 - average interval 10
 - cycle count interval 10
 - location 9
 - location type 10
 - lot/serial control 9
 - memo order type 11
 - shelf life 10
 - site 9
- Inventory Control 234
 - ABC tolerances 247
 - cycle counting 247
 - location search order 47
 - Site 9
- Inventory Detail by Item Browse 275
- Inventory Detail by Location 273
- Inventory Detail by Site Browse 275
- Inventory Detail Report 272
- inventory reports
 - Current Surplus Inventory Report 273

- Detail Allocation Inventory Report 272
 - Inventory Detail by Location 273
 - Inventory Detail Report 272
 - Inventory Valuation as of by Loc 274
 - Inventory Valuation as of Date 274
 - Inventory Valuation by Location 274
 - Inventory Valuation Report 274
 - Item ABC Status Report/Update 272
 - Projected Surplus Inventory 273
 - Reorder Report 272
 - Stock Status Report 272
 - inventory status
 - blank 148
 - changing 147, 151
 - PO receipt status 145
 - regulatory attributes effect 145
 - WO receipt status 145
 - Inventory Status Code Maintenance 51
 - inventory transactions 238, 239
 - expired 161
 - issues 240
 - receipts 240
 - shipments 243
 - transfers 239
 - Inventory Type Item Report 271
 - Inventory Type Maintenance 255
 - Inventory Type Report 251
 - inventory types
 - action for conflicts 251
 - defining 253
 - display options 250
 - examples 254
 - overlapping types 255
 - Inventory Valuation as of by Location 274
 - Inventory Valuation as of Date 274
 - Inventory Valuation by Location 274
 - Inventory Valuation Report 274
 - Inventory Variance Report 280
 - invoices 33
 - ISS-DO 253
 - ISS-SO 252
 - issues 240
 - inventory transactions 240
 - transactions, specifying 252
 - Issues-Return to Supplier 240
 - Issues-Unplanned 240
 - ISS-UNP 252
 - ISS-WO 252
 - Item ABC Status Report/Update 272
 - Item Cost Maintenance 104
 - Item Cross-Sell Maintenance 19
 - Item Data frame 122
 - Item Data Maintenance 121, 122
 - change control 104
 - Item Inventory Data Maintenance 9, 104
 - auto lot numbers 158
 - change control 104
 - cycle count interval 247
 - direct item access 122
 - lot groups, assign 158
 - Item Inventory Type Report 271
 - Item Master Comments Report 6
 - Item Master Copy 158
 - Item Master Maintenance 5, 67
 - auto lot numbers 158
 - cycle count interval 247
 - logistics costs 213
 - lot groups, assign 158
 - Item Number field 24
 - Item Planning Maintenance 122
 - change control 104
 - item replacement
 - customer items 21
 - Item Replacement Control 16
 - Item Replacement Maintenance 17
 - setting up 23
 - Item Revision History Inquiry 109
 - Item Specification Maintenance 104
 - Item Up-Sell Maintenance 19
 - items 4-15
 - ABC classification 8
 - alternate unit of measure 8
 - analysis codes regeneration 59
 - automatic replacement 16
 - codes, identify and categorize 6
 - cost categories 14
 - cost data 5, 14
 - cross-sell 16, 19
 - current costs 14
 - customer 15
 - general data 7
 - generalized codes 7
 - GL cost 14
 - groups 8
 - inventory data 8, 9
 - logistics costs 213
 - master comments 6
 - multiple sites 6
 - number 7
 - PCR/PCO update of 121
 - planning data 12
 - price break categories 58, 66
 - price default 14
 - Pur/MFG code 13
 - replacement 15-19
 - shipping data 12
 - supplier 15
 - types 8
 - unit of measure 8
 - up-sell 15, 16, 19
 - Item-Site Cost Maintenance 14, 122
 - Item-Site Inventory Data Maint 104, 122
 - Item-Site Planning Maintenance 122
- L**
- L type price list 88
 - la_do_ship_id 205
 - la_so_ship_id 205
 - Language Detail Maintenance 17
 - levels in analysis output 265
 - life cycle of a PCR/PCO 106
 - linking analysis codes 61, 64
 - list price 77
 - list type, address 171
 - Location Maintenance 46, 47, 48
 - locations 46-52
 - and picklists 47
 - automatic 48

- naming conventions 47
- overview 46
- permanent/temporary 47
- reserved 48, 178
- single item 48
- types 48
- Log Charge Pending Voucher Maint 229
- logical expressions, in reports and data 250
- logistics accounting 195–231
 - apportioning charges 197
 - charge codes 206
 - inbound accrual 212
 - matching charges 230
 - outbound accrual 223
 - PO receipts 221
 - setting up 202
 - shipments 226
 - tax calculation 210
- Logistics Accounting Control 204
- Logistics Charge Code Maintenance 206
- logistics charges
 - defining 206
 - terms of trade 214
- Lot Actual Bill Inquiry 151, 246
- lot control
 - benefits 141
 - hierarchy 154
 - item level 155
 - levels 142, 153, 155
 - lot master records 156
 - order level 155
 - regulatory attributes 152
 - workflow 153
- Lot Group Maintenance 158
- lot groups
 - assigning to items 158
 - creating 158
- Lot Master Build 156
- Lot Master Delete/Archive 153
- Lot Master Maintenance 157, 161
- lot master records
 - building 156
 - modifying 157
- lot numbers
 - auto lot numbering 153, 158
 - duplicate 153
 - expired inventory 161
 - multiple-database 153
 - reusing 153
 - supplier 153, 161
- Lot Transactions by Date Browse 151, 246
- Lot Transactions by Tran Inquiry 246
- Lot Where-Used Inquiry 151, 246
- lot/serial history 246

M

- M type price list 88
- Maintain Users in Groups 112
 - adding users 112, 113
 - removing users 114
 - replacing users 113
- manual price lists 85
- mapping customer demand 20
- mapping, demand 20

- master
 - comments
 - copying text into PCO 121
- Master Comment Maintenance 6
- Master Line field 27
- master lines
 - creating 27
 - features 21
 - planning requirements 30
 - shipping requirements 30
- material requirements planning (MRP) 12
- memo order type 11
- minimum price 59
- minimum/maximum cost for price tables 98
- Move Transaction
 - auto lot numbers 159
- Multi-Lot Inven. Detail Update 151
- multiple database sites 42
- Multiple Work Order Release Print 151

N

- NAFTA 182
- National Drug Codes 162
- net cost, calculating 98
- non-nettable inventory 268
- notification, PCC approvals 115
- Number Range Maintenance 204
- Number Range Management (NRM)
 - logistics accounting 203
- numbers
 - auto lot 153
 - items 7
 - PCR/PCO 110

O

- Obsolete Inventory Analysis 262
- obsolete inventory analysis 248–271
- Obsolete Inventory Control 250
- operational addresses
 - bill-to, ship-to 173
 - carrier 183
 - company 172
 - customer 174
 - deleting 173
 - list types 171
 - salesperson 173
 - supplier 179
 - taxes 173
- orders, processing 31
- Outbound Accrual Account Maintenance 208
- Outbound Expense Account Maintenance 208
- output file
 - characters 259
 - CSV format 259
 - naming 266
 - sequence of fields 258, 260
 - setting up 258
 - specifying levels 265
- Output File Type field 259
- Output File Type Maintenance 258
- overissues 52
- overlapping dates on price lists 87
- overlapping inventory types 255
- overriding prices on orders 97

P

- P type price list 88
- PCC Control 109
- PCC. *See* product change control (PCC)
- PCO Maintenance 118–129
 - Formula Data Maintenance
 - Copy Formula into PCO 127
 - Copy Formula within PCO 127
 - Copy Where Used into PCO 127
 - Deactivate a formula 127
 - PCR/PCO Detail Maintenance–Formulas 127
 - Replace Formula Component 127
 - header 118
 - Item Data Maintenance 121
 - Add, Modify, Delete PCO Item Data 122
 - Direct Item Master Access 122
 - Item Specification Maintenance
 - Add/Edit/Deactivate Item Specification 128
 - Copy Item Spec From Quality Module 128
 - PCO/PCR Function Maintenance
 - Change PCO Number 120
 - Close PCO to PCO 120
 - Copy PCO from PCR/PCO 120
 - Copy PCO to PCR/PCO 120
 - Process Data Maintenance 128
 - Routing Data Maintenance
 - Add/Edit/Deactivate Routing 126
 - Add/Edit/Deactivate Routing (Rate Based) 127
 - Copy Routing to PCR/PCO 126
 - Section Menu 119
 - Structure Data Maintenance 123
 - Copy Product Structure within PCO 125
 - Copy Product Structures into PCO 123
 - Copy Routing within PCO 127
 - Copy Where Used into PCO 124, 125, 127
 - Deactivate Product Structure 125
 - Deactivate Routing 127
 - Product Structure detail 124
 - Replace Product Structure Component 124
 - Text Data Maintenance 121
 - Add, Modify, Delete PCO Text Data 121
 - Copy Text from Master Comments 121
 - Trailer Maintenance 129
- PCO Number field 25
- PCO Status Browse 129
- PCO. *See* product change order (PCO)
- PCR Maintenance 118
 - PCO/PCR Function Maintenance
 - Close PCR to PCO 121
 - Convert PCR to PCO 121
- PCR. *See* product change request (PCR)
- PCR/PCO Approval 131
 - monitor queue 107
 - verify user 110
- PCR/PCO Close 136
- PCR/PCO Detail Inquiry 129
- PCR/PCO Import/Export 119, 136
- PCR/PCO Type Maintenance 117, 119
- pending vouchers
 - updating 229
- percentages for depreciation rates 257
- periods, GL 263
- permanent locations 47
- physical inventory 277–280
 - creating and printing tags 279
 - deleting/archiving old tags 278
 - freezing inventory balances 278
 - recount information 280
 - reviewing results 280
 - update balances 280
- picking logic 234
 - inventory 234
 - options 235
- picklists 32
- planning data 5, 12
- PO Fiscal Receiving 218
- PO Receipts accounts 180
- PO Shipper Maintenance 218
- PO Shipper Receipt
 - logistics charges 221
- PO Shipper Receipt Into Transit 220
- PO Shipper/Invoice Maintenance 220
- Preference Criteria Codes 162
- Price List Copy 77
- Price List Generation by Item 92
- Price List Inquiry 77
- Price List Maintenance 67, 73
- Price List Reclassification 99
- Price List Report 77
- price lists
 - combination type 74
 - copying 77, 93
 - creating 67
 - defaults 89
 - discount sequence 75
 - generating 92
 - incremental 68
 - manual 85
 - overlapping dates 87
 - overriding prices on orders 97
 - quantity break type 74
 - reclassifying 99
 - reports 99
 - requiring 97
 - rounding methods 96
 - start and end dates 87
 - types 88
 - unit of measure 73
- Price Lists by Customer Inquiry 77
- Price Lists by Item Inquiry 77
- pricing
 - analysis codes 60
 - assigning lower net 71
 - best pricing 58
 - break categories 58, 66
 - calculating best 71
 - calculating net cost 98
 - effective date 60
 - inquiries 79
 - list/discount table 86
 - overriding on orders 97
 - promotional discount 59
- Pricing Control 59
- Pricing What-If Inquiry 79
- Print PCR/PCO 129
- printing
 - cycle count worksheets 247
 - ECO 109

- process update for PCR/PCO 128
 - processing orders 31
 - product change control (PCC)
 - auto numbering 110
 - security 110
 - setting up 108
 - user IDs 109
 - product change order 25
 - product change order (PCO)
 - adding, modifying, and deleting text data 121
 - approval 107, 131
 - auto numbering of 118
 - changing numbers 120
 - closing 136
 - closing PCO to PCO 120
 - copying from PCR/PCO 120
 - copying to PCR/PCO 120
 - data affected by 104
 - distribution 132
 - effective dates 105, 134
 - evaluating impact on inventory 133
 - ID 118
 - implementation 108, 135
 - importing and exporting 136
 - incorporating into production 135
 - incorporation 108
 - initializing 109
 - item data maintenance 121
 - life cycle 106, 107
 - master comment 121
 - multi-database installations and 119
 - overview 105
 - prefixes for numbers 111
 - printers and batch IDs 109
 - process data maintenance 128
 - product structures in 123
 - release 132
 - release and distribution 108
 - reopening 129
 - rerouting 131
 - revision levels 123
 - routing for approval 107, 130
 - security issues 136
 - text data maintenance 121
 - trailer maintenance 129
 - types of data in 118
 - viewing data 129
 - product change request (PCR)
 - approval 107
 - life cycle 106
 - routing for approval 107
 - types of data in 118
 - Product Line Accounts Copy 38
 - Product Line Copy 38
 - Product Line Maintenance 37
 - Product Line Replacement 39
 - product lines 34–40
 - accounts 36
 - alternate accounts 37
 - copying 38
 - copying accounts 38
 - defining 34
 - replacement 39
 - Product Structure Maintenance 104
 - product structures
 - maintaining in PCR/PCO 123
 - restricting component issues to 162
 - Projected Surplus Inventory 273
 - promotions prefix, pricing 60
 - Pur/Mfg code 13
 - Purchase Order Cost Update 217
 - Purchase Order Maintenance
 - logistics accounting 216
 - Purchase Order Receipts
 - attributes 147
 - auto lot numbering 159
 - logistic charges 221
 - Purchase Order Returns 222
 - purchase orders 144
 - memo type 11
 - regulatory attributes 143
 - single lot per receipt 143
 - terms of trade 216
- Q**
- QOH. *See* quantity on hand balance
 - quality management
 - PCC control of item specifications 128
 - quantity break types 74
 - Quantity field 25
 - quantity on hand balance
 - as of analysis date 264
 - as of GL period end date 264
 - extracting 252
 - in analysis 262
 - reporting 264
 - retaining 252
 - with demand 264
 - quote character, output file 259
 - quotes. *See* sales quotes
- R**
- Reason Codes Maintenance, severity lists 115
 - receipts
 - inventory 240
 - status 145, 146
 - Receipts–Backward Exploded 240
 - Receipts–Return to Stock 240
 - Receipts–Sales Order Return 240
 - Receipts–Unplanned 240
 - reclassifying price lists 99
 - Regional Value Content 162
 - regulatory attributes 140–167
 - activate 142
 - automatic lot numbers 158
 - co-products/by-products receipts 142
 - inventory attributes 143
 - lot control 152
 - overriding defaults 147
 - repetitive receipts 143
 - setting up 141
 - work order batch control 143
 - Regulatory Attributes Control 141
 - Release and Distribution 133
 - monitor queue 108
 - notification group 117
 - reference summaries 119
 - Reorder Report 272

- Rep Quantity field 25
 - Repetitive Labor Transaction
 - auto lot numbering 159
 - repetitive receipts
 - single lot restriction 143
 - repetitive transactions
 - inventory attributes 144
 - replacement creation 21
 - Replacement Item field 25
 - replacements 15–19
 - automatic 16
 - item 17
 - product line 39
 - rounding method 16
 - search by 17
 - reporting
 - inventory type IDs 271
 - items within inventory types 271
 - reports
 - Cust Schedule Price List 57
 - Cust Schedule Price List by Item 91
 - enhanced .NET UI 281
 - list of pricing reports 99
 - Supplier Price List by Item 57, 91
 - repricing 81–84
 - Required Ship Schedules
 - effective date warnings 20
 - item replacement functions 30
 - new features 22
 - updating 30
 - reserve data
 - definition 248
 - path for output 252
 - reporting 271
 - Reserved Location Browse 49
 - Reserved Location Maintenance 48, 179
 - Reserved Location Report 49
 - reserved locations 48
 - creating 178
 - inventory status 49
 - primary 49
 - retaining consumption data 252
 - revision levels, PCC 123
 - RMA Maintenance 86
 - rounding method, replacements 16
 - rounding methods, price lists 96
 - Route PCO for Approval 107, 130
 - Route PCR for Approval 107
 - Routing Slip Copy 116
 - Routing Slip Maintenance 114
 - details 115
 - RTS Receipts
 - auto lot numbering 159
- S**
- Sales Order Control
 - pricing fields 98
 - Sales Order Maintenance 83, 85
 - logistics accounting 224
 - Sales Order Manual Allocations 11
 - Sales Order Price Inquiry 80, 83
 - Sales Order Pricing Report 84
 - Sales Order Repricing 81, 83
 - sales orders
 - default pricing date 60
 - display discounts 60
 - factor rounding 60
 - memo type 11
 - price by Line 60
 - repricing 81–84
 - Sales Quote Price Inquiry 83
 - sales quotes
 - default price date 60
 - display discounts 60
 - factor rounding 60
 - price quote by line 60
 - repricing 81–84
 - Salesperson Maintenance 173
 - Salesperson Payments Report 174
 - salespersons
 - commissions 173
 - territory codes and 173
 - Schedule Discount Table Req field 97
 - scheduled order
 - required discount table 97
 - required discount tables 97
 - Scheduled Order Maintenance 216
 - Scrap Reports
 - Financial 275
 - Item 275
 - searching contract lines 21
 - security
 - PCR/PCO 110
 - Product Change Control module 136
 - separator character, output file 259
 - sequence of fields, output file 258
 - sequences, discount 71
 - setting cumulative end effective quantity 28
 - setting up
 - PCC module 109
 - setting up customer item cross-references
 - customer items cross-references to internal items 22
 - setting up internal part change over 22
 - setting up item replacements 23
 - severity level 116
 - severity list 115
 - shelf life 10
 - Shipment ASN Export 32
 - shipping data 12
 - shipping with internal part number changes 32
 - single item locations 48
 - single lot
 - per receipts 147, 153
 - receipt restrictions 143
 - Site field 24
 - Site Maintenance 42
 - site security compliance 140
 - Site Security Maintenance
 - and Regulatory Attributes 140
 - sites 40–46
 - domain 41
 - entity links 43
 - overview 40
 - uses of 40
 - SSM Accounting Control 40
 - start and end dates, price lists 87
 - status
 - inventory 50, 145

- PCR/PCO 129
- Stock Availability Browse 275
- Stock Journal 274
- Stock Status Report 272
- substitute items, restricting issues 162
- Supplier Accounts Data Maintenance 180
- Supplier data Maintenance 179
- Supplier Item Maintenance 15
- supplier items 15
- Supplier Price List Browse 57
- Supplier Price List by Item Report 57
- Supplier Price List Copy 57
- Supplier Price List Gen by Item 57
- Supplier Price List Maintenance 57
- Supplier Price List Maintenance (1.10.2.1) 89
- Supplier Price List Report 57
- Supplier Pricing Menu 57
- supplier-consigned inventory 267
- suppliers
 - blocking transactions 189
 - lot numbers 153, 161
 - matching blank 206
 - operational data 179
 - terms of trade 215
- supply coverage
 - calculating 264
 - reporting 271

T

- Tag Count Entry 280
- Tag Delete/Archive 278, 279
- Tag Inquiry 279
- Tag Print 279
- Tag Recount Entry 280
- Tag Report 279
- Tag Void Status Update 280
- tax transaction types, logistics charges 210
- taxes, company address 173
- temporary locations 47
- terms
 - freight 188
 - trade 214
- Terms of Trade Maintenance 214
- Trailer Code Maintenance 184
- trailer codes
 - defaults 185
 - taxable 184
- Transaction by Item Inquiry 245
- Transaction Detail Inquiry 151, 245
- Transaction History Menu 245
- Transaction Numbering Report 245
- transaction types
 - expired inventory 161
 - inventory 243
- transactions
 - blocking 189
 - extracting 260
 - specifying 252
- Transactions Accounting Report 245
- Transactions by Item Report 245
- Transactions by Order Browse 245
- Transactions by Order Report 245
- Transactions Delete/Archive 245
- Transactions Detail Report 245

- Transfer With Lot/Serial Change 239
- Transfer–Multi Item 239
- transfers, inventory 239
- Transfer–Single Item 239
- transit locations 219
- type
 - inventory transactions 243
 - location 48
 - PCR/PCO 117
- Types of price lists 88

U

- Unallocated Inventory Inquiry 276
- Uncounted Tag Report/Update 279, 280
- Unicode database 42
- unit of measure 8
 - acceptable values 8
 - alternates 8
- update, consumption data 261
- up-sell items 15, 19
- User Maintenance, PCC groups 109
- users, adding to PCC groups 112

V

- variable overhead 14
- viewing pricing data 99
- viewing Purchasing Control settings 98
- Void/Zero Count Unused Tags 280
- volume discounts 59
- vouchers
 - pending 229

W

- warnings, end effective 28
- Work Order Attribute Maintenance 143
- Work Order Batch Browse 151
- Work Order Bill Maintenance 11
- Work Order by Item Report 151
- Work Order by Order Report 151
- Work Order History Report 151
- Work Order Maintenance
 - inventory attributes 143
- Work Order Operation Backflush
 - auto lot numbering 159
- Work Order Receipt
 - attributes 147
 - auto lot numbering 159
- Work Order Receipt Backflush
 - auto lot numbering 159
- Work Order Release Print 151
- Work Order Split 151
- Work Order Status Report 151
- work orders
 - component issues 162
 - inventory attributes 143
 - regulatory attributes 143
 - single lot per receipt 143

Z

- Zero Balance Delete/Archive 47
- zero demand/consumption, depreciation rates 256
- zones, freight 187