



User Guide

QAD Configurator

Welcome to QAD Configurator
QAD Configurator Basics
QAD Configurator Workspace
Configurator Setup
Sales Configuration
Product Configuration
Configuration Questionnaire
Administration

This document contains proprietary information that is protected by copyright and other intellectual property laws. No part of this document may be reproduced, translated, or modified without the prior written consent of QAD Inc. The information contained in this document is subject to change without notice.

QAD Inc. provides this material as is and makes no warranty of any kind, expressed or implied, including, but not limited to, the implied warranties of merchantability and fitness for a particular purpose. QAD Inc. shall not be liable for errors contained herein or for incidental or consequential damages (including lost profits) in connection with the furnishing, performance, or use of this material whether based on warranty, contract, or other legal theory.

QAD and MFG/PRO are registered trademarks of QAD Inc. The QAD logo is a trademark of QAD Inc.

Designations used by other companies to distinguish their products are often claimed as trademarks. In this document, the product names appear in initial capital or all capital letters. Contact the appropriate companies for more information regarding trademarks and registration.

Copyright ©2012 by QAD Inc.

Configurator_UG_v053.pdf/c6s/c6s

QAD Inc.

100 Innovation Place
Santa Barbara, California 93108
Phone (805) 566-6000
<http://www.qad.com>

Contents

Change Summary	vii
Chapter 1 Welcome to QAD Configurator	1
QAD Configurator General Workflow	2
Integration With QAD Enterprise Applications	2
Support for QAD EA Domains	3
Integration with QAD Trade Management	3
Chapter 2 QAD Configurator Basics	5
Configurable Item, Generic Product Structure, and Generic Routing	6
Variables and Features	7
Variable and Feature Data Types	7
Variable and Feature Options	8
Sales Configuration Rules	9
Rule Statement Formats	10
Sales Configuration Rule Grouping and Application	11
Analysis of Sales Configuration Rules	12
Feature Relationships	13
Feature Sequences	16
Multi-Level Analysis	17
Configuration Keys	18
Product Configuration Rules	19
Selection Rules	20
Assignment Rules	20
Item Number Definition Rules	20
Dynamic Update of Routing Operation Comments	21
Cost Roll-Up	21
Element Roll-Up	22
Cross Validation of Rules	24
What the Cross Validation Analyzer Checks	24
Example of Using the Cross Validation Analyzer	25
Cross Validation Analyzer Report	26
Questionnaire	26
Questionnaire Questions	27
Configurations	27

Pricing	27
Chapter 3 QAD Configurator Workspace	31
Workspace Overview	32
Accessing QAD Configurator Functions	32
Application Toolbar	33
Selecting a Master Group	33
Maintaining Records	33
Editing Comments	35
Using the Rule Assistant	35
Using Browsers and Browse Collections	35
Customizing the Configuration Browse	38
Chapter 4 Configurator Setup	39
Setting Up Data in QAD EA	40
Creating Items	41
Creating Generic Product Structure	42
Creating Generic Routings	42
Setting Up QAD Configurator	42
Configuring System Settings	43
About Master Groups	44
Maintaining Master Groups	45
Maintaining Configurable Items	47
Copying Configurable Item Data	54
Maintaining External Entities	55
Chapter 5 Sales Configuration	57
Sales Configuration Overview	59
Maintaining Question Types	59
Maintaining Functional Groups	60
Maintaining Variables and Features	60
Maintaining Variables	60
Maintaining Features	67
Maintaining Feature Sequence	68
Using System Variables	69
Maintaining Sales Configuration Rules	71
Maintaining General Rules	71
Grouping Sales Configuration Rules	76
Maintaining General Rules in Rule Groups	77
Maintaining Rule-Group-Specific Rules	77
Applying Sales Configuration Rules	77
Applying General Rules and Rule Groups to Configurable Items	78

Maintaining Item-Specific Rules	78
About Sales Configuration Rule Table	79
Rule Table Shortcut Keys	80
Rule Table Limitations	81
Interpolation	81
Interpolation Process	82
Maintaining General Rules Using General Rule Tables	83
Generating Rule Tables	83
Editing Rule Tables	87
Maintaining Item Rule Tables	90
Linking General Rule Tables to Configurable Items	91
Maintaining Item-Specific Rule Tables	91
Accelerating Rule Tables	92
Sales Configuration Rules Report	93
Analyzing Sales Configuration Rules	93
Results of the Analysis	94
Maintaining Questions Sequence	95
Maintaining Configuration Keys	96
Configuration Key Maintenance and Pricing	96
Where-Used Report	97
Chapter 6 Product Configuration	99
Product Configuration Overview	100
Maintaining Product Configuration Rules	101
Maintaining Variant Item Number Rules	101
Maintaining Variant Item Data Rules	103
Maintaining Variant Planning Item Rules	104
Maintaining Variant Item Product Structure Rules	105
Maintaining Variant Routing Rules	109
Maintaining Variant Sales Order Line Rules	111
Maintaining Variant Sales Quote Line Rules	112
Maintaining General Product Structure Rules	112
Maintaining Element Roll-Up Rules	113
Maintaining External Entity Rules	114
Using Custom Functions in Product Configuration Rules	115
Running Product Configuration Rule Report	116
Cross-Validating Rules	117
Chapter 7 Configuration Questionnaire	119
Launching Questionnaire	120
Navigating in Questionnaire	120
Exiting Questionnaire	122

Variant Item Configuration Workflow	123
Using Standard/Existing Configurations	125
Browsing Standard / Existing Configurations	125
Searching for Configurations	126
Ordering an Existing Variant Item	127
Creating a Variant Item	128
Reloading a Configuration	128
Creating a New Configuration	128
Configuring Item	129
Answering Questions	129
Reviewing Answer Summary	130
Editing Comments	130
Customizing the Questionnaire	131
Reviewing and Submitting Configuration	133
Reviewing Current Configuration	133
Viewing Similar Configurations	133
Submitting Configuration	134
Chapter 8 Administration	137
Administration Functions Overview	138
Performing Element Roll-Up	138
Maintaining Component Effective Dates	139
Maintaining Routing Effective Dates	139
Importing and Exporting Data	140
Creating Data Package	140
Loading QAD EA and QAD Configuration Data	142
Deleting and Archiving Configurations	143
Changing Configurable Item Numbers	144
Maintaining Configurations Manually	144
Rebuilding Configurations	146
Rebuild for Multi-level Configurations	149
Running Batch Compiler	152
Maintaining Standard Configurations	153
Using Configurator Metrics	154
Configurator Best Practices	154
Using Placeholder Component	154
Using Base Price for Configurable Items in Questionnaire	155
Populating Fields in Variant Item-Site Planning Records	155
Index	157

Change Summary

The following table summarizes significant differences between this document and the last published version.

Date/Version	Description	Reference
September 2011/5.2.2	Rebranded for 5.2.2	-
September 2011/5.2.2	Added a <i>Show All Options of Feature</i> setting for Configurable Item Maintenance	Page 50
September 2011/5.2.2	Added a <i>Customer Specific List Price</i> setting for Configurable Item Maintenance	Page 50
September 2011/5.2.2	Added a <i>Copy from Variable</i> button for Variable Maintenance	Page 61
September 2011/5.2.2	Added enhancement for <i>Browse Code</i>	Page 62
September 2011/5.2.2	Added a <i>Browse Code</i> browse for Feature Maintenance	Page 67
September 2011/5.2.2	Changed descriptions about a system variable <i>sysVariantItemID</i>	Page 70
September 2011/5.2.2	Added a <i>Copy from Rule Table</i> button for Generating Rule Tables	Page 83
September 2011/5.2.2	Changed descriptions for Editing Rule Tables	Page 88
September 2011/5.2.2	Added options <i>Validate Orphaned Rule</i> and <i>Delete Orphaned Rule</i> for Cross Validation Analyzer	Page 117
September 2011/5.2.2	Updated the section of Using Custom Functions in Product Configuration Rules	Page 115
September 2011/5.2.2	Added an option <i>Show all options of feature</i> setting for questionnaire customization in Configuration Questionnaire	Page 132
September 2011/5.2.2	Added an <i>Effective Date</i> setting for Configuration Rebuild	Page 148
March 2012/5.3	Rebranded for 5.3	-
March 2012/5.3	Added a note about <i>Allow Net Price Change</i> and <i>Allow Manual Price List Change</i>	Page 45
March 2012/5.3	Added a note about <i>Browse Code</i>	Page 62
March 2012/5.3	Added system variables <i>sysConfigurationCmmt</i> , <i>sysConfigurationDesc</i> , <i>sysExtLaunch</i> and <i>sysQuestLaunch</i>	Page 69
March 2012/5.3	Updated the number of features that form a configuration key	Page 96
March 2012/5.3	Added a <i>Standard Configurations</i> tab in Configuration Questionnaire	Page 120
March 2012/5.3	Added a note about viewing question rules	Page 130
March 2012/5.3	Updated the section of Maintaining Configurations Manually	Page 144
March 2012/5.3	Added a section of Rebuild for Multi-level Configurations	Page 146
March 2012/5.3	Added a function <i>Standard Configuration Maintenance</i>	Page 153
March 2012/5.3	Added a section of Configurator Best Practices	Page 154

Welcome to QAD Configurator

QAD Configurator is a rules-based product configuration and guided selling tool that allows make-to-order and assemble-to-order companies to quickly and efficiently create sales orders based on specific customer requirements and ultimately manufacture and fulfill complex, customized products and services. It is an add-on module to QAD Enterprise Applications (QAD EA) and provides flexible and powerful product configuration and computer-aided order entry capabilities.

QAD Configurator is specifically designed for manufacturing companies who produce products that are highly configurable or are routinely customized to meet the unique needs of their customers. By seamlessly integrating into QAD's order entry process, QAD Configurator ensures complete and valid product configuration during order entry and instantaneously translates customers' unique product requests into quotations, sales orders, bills of material and routings.

QAD Configurator effectively bridges the information and knowledge gap between product engineering and sales by allowing sales personnel to access the most current product data maintained by engineering personnel and enter orders with complex configurations based on customers' specific requirements without having to know the product details and possess a strong technical background.

QAD Configurator General Workflow 2

Configurator process map and workflow details.

Integration With QAD Enterprise Applications 2

Integration and support for ERP domains.

Integration with QAD Trade Management 3

Integration and support for QAD Trade Management.

QAD Configurator General Workflow

Fig. 1.1
QAD Configurator Process Map

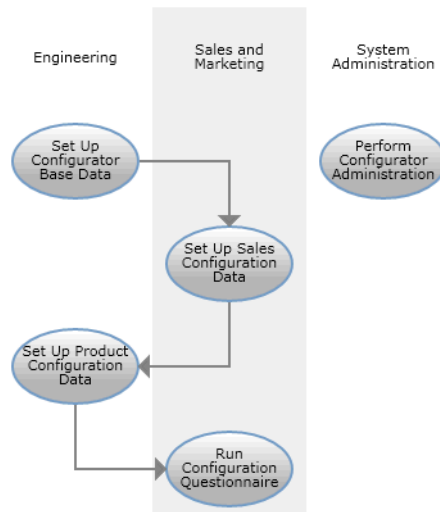

1 System Setup

Prior to using QAD Configurator, perform system setup including setting up data in QAD EA and configuring Configurator settings.

2 Sales Configuration

Sales personnel maintain variables and features that define configurable product characteristics, designate how to present features as questions in the guided sales process – questionnaire, as well as set up sales configuration rules to ensure data collected from the questionnaire is valid.

3 Product Configuration

Engineering personnel define product configuration rules that translate feature data collected from questionnaires into product structures and routings of configured products.

4 Guided Sales

Sales personnel run the questionnaire during order or quotation entry to configure products to meet specific customer needs. Data collected in this guided sales process identify new product configurations and translate new customer requirements into new product structures and routings.

5 Administration

Use a range of administrative functions to maintain the system for optimal performance.

Integration With QAD Enterprise Applications

QAD Configurator is integrated with the following QAD EA functions:

- Sales Quote Maintenance (7.12.1)
- Sales Order Maintenance (7.1.1)
- Item Master Maintenance (1.4.1)

- Product Structure Maintenance (13.5)
- Routing Maintenance (14.13.1)
- Item-Site Inventory Data Maintenance (1.4.16)
- Item-Site Planning Maintenance (1.4.17)
- Item-Site Cost Maintenance (1.4.18)

QAD Configurator does not use any of the standard functions in QAD EA's Configured Products module.

Support for QAD EA Domains

QAD Configurator fully supports multiple domains in QAD EA. However, not all of its functions are domain-specific. While some Configurator functions retrieve and process data only available in the current domain, other functions work with data across domains, due to the nature of the data these functions deal with.

Configurator functions that work with item-related data, which is domain-specific itself, are domain-enabled.

The following Configurator functions are not domain-enabled since the data they work with is not associated with any specific domain and can be accessed across domains:

- Master Group Maintenance
- Question Type Maintenance
- Rule Group Maintenance
- Variable Maintenance
- Functional Groups
- General Rules

Integration with QAD Trade Management

QAD Configurator can be integrated with QAD Trade Management. If you want to integrate the Configurator variant item creation process with the QAD Trade Management product, you must apply the Configurator-TrM integration patch and perform some additional steps. See *Installation Guide: QAD Configurator* for details.

If Integrate with TrM is Yes in Sales Order Control (7.1.24) but the TrM Item API patch is not applied, the system displays the following error message when you try to create a variant item:

TrM Integration detected. Please apply TrM Item API patch first.

After you integrate QAD Configurator with QAD Trade Management, when creating a variant item, the system copies TrM product data as well as product division data from the configurable item to the variant item.

QAD Configurator Basics

***Configurable Item, Generic Product Structure, and Generic Routing* 6**

Outlines the concepts of configurable items, generic product structures, and generic routings.

***Variables and Features* 7**

Discusses variable and feature data types and options.

***Sales Configuration Rules* 9**

Explains some of the rules and rule statement formats.

***Sales Configuration Rule Grouping and Application* 11**

Outlines how rules are grouped and linked to different items in order to increase their effectiveness.

***Analysis of Sales Configuration Rules* 12**

Explains how rules apply to questionnaires, as well as how rule feature relationships and feature sequences work; describes multi-level analysis.

***Configuration Keys* 18**

Explains how configuration keys apply to variants.

***Product Configuration Rules* 19**

Discusses different configuration rules and processes, including selection rules, assignment rules, item number definition rules, and dynamic updates of routing operation comments.

***Cost Roll-Up* 21**

Explains how costs are calculated and roll-ups are completed.

***Element Roll-Up* 22**

Outlines the element roll-up process and requirements.

***Cross Validation of Rules* 24**

Discusses the Cross Validation Analyzer function, what it checks, gives an example, and discusses Cross Validation Analyzer Report.

***Questionnaire* 26**

Describes how questionnaire questions are generated and gives information on the configurations that result from completing a questionnaire.

***Pricing* 27**

Discusses Configurator's pricing functionality.

Configurable Item, Generic Product Structure, and Generic Routing

Configurable item, generic product structure, and generic routing are a set of inter-related concepts.

A **configurable item** is a virtual, non-buildable item that can be configured to form various end products — or variant items — that can be actually manufactured to meet specific customer requirements. As the parent item for a particular generic product structure, the configurable item identifies the complete list of child items and customer-selectable components and sits at the top of the product structure to tie them together. A configurable item can also be the parent item of other configurable items.

A **variant item** is a configured end product created from a configurable item. As opposed to a configurable item, which is virtual and non-buildable, a variant item can be actually ordered and manufactured.

A **generic product structure** is an artificial grouping of all possible component items — even mutually-exclusive ones — that go into a configurable item showing the quantity of each required to make an assembly.

Unlike a common product structure, a generic product structure can not be used directly to build components or end products. It is used in conjunction with QAD Configurator to simplify and facilitate order processing and fulfillment by selecting component items from the generic product structure to create product structures for buildable variant items based on specific customer requirements.

Note Generic product structure and generic bill of material (BOM) are used interchangeably in this book.

Example An electrical product has three different power cords for use in different countries, but in each variant of the product that you configure for each country, there is only one appropriate power cord for that country. The generic product structure includes all three power cords, but each variant product structure includes only one.

A **generic routing** of a configurable item includes all possible operations that may be performed to build any possible variant of a configurable item. Generating a variant routing means selecting the correct operations for your configured variant from the generic routing.

Like generic product structure, generic routings are artificial and unrealistic listings of operations that can not be directly used to manufacture products.

Example A variant routing for a product that has only one control panel includes either anodizing an aluminium control panel or electroplating a steel control panel, but not both. The generic routing, however, includes both processes.

The primary purpose of using configurable items, generic bills material and routing is to simplify order processing and master schedule planning.

Example Suppose a company manufactures tables with five different leg styles, three different sides and ends, and ten different tops. In total, they are making $5 \times 3 \times 10 = 150$ different tables, each with its own product structure and routing.

When placing orders for a table, customers have to pick their desired configurations from a long list of 150 different tables. When master planning for the product, the master scheduler have to maintain 150 different product structures and routings for all table variations.

This can be simplified by just creating one configurable item and one set of generic product structure and routing for that item. Using QAD Configurator, customers can specify the table they want by selecting options for the three features — leg style, sides and ends, and top — respectively. QAD Configurator then creates a variant item for each new configuration of table customers order and automatically generates the corresponding product structure and routing.

Variables and Features

You define all the configurable aspects of your products using variables and features. **Variables** are shared configurable characteristics of products that accept certain values (options) or a range of values. By linking a variable to a configurable item, you create a feature — a configurable product characteristic specific to that configurable item. The feature inherits its properties from the variable, including ID, data type, and data format. As to options, you can choose to inherit feature options from variable options or create a new set of feature options.

Example Color is defined as a variable for your products with three options: blue, red, and white. By linking this variable to a configurable item, you create a feature which inherits the three options of the Color variable. You can use the inherited options as is or define new feature options by adding new color options or removing inherited ones.

Variables and features always pertain to a certain master group. Make sure you have selected the right master group when you maintain variables and features.

Features are domain-specific but variables are available across domains.

Variable and Feature Data Types

Variables and Features have six data types that represent different data formats and acceptable values or value ranges. After you first define the data type of a variable, it can no longer be changed either in variable maintenance or when it is inherited to a feature since different data types have incompatible data formats and acceptable values.

Table 2.1
Variable and Feature Data Types

Data Type	Description
Numeric	Accepts numeric values that can be used in calculations. You can set the range of acceptable values by specifying a maximum value and/or a minimum value. You can also set the multiplier attribute to specify increments between acceptable values. Length, width, and weight are examples of numeric variables and features.
Text	Accepts a list of predefined text values which cannot be used in calculations. Examples include Color, with options blue, white, and red, and body type, with options saloon, coup, and hatchback. Select Free Format to accept additional user input.

Data Type	Description
Numeric List	Accepts a list of predefined numeric values or options that can be used in calculations. Examples include Engine Capacity, with options 1300, 1600, 1900, 2300, and Voltage, with options 115, 220.
Date	Accepts the current date, a fixed date, or a list of predefined date options, depending on which date format you select.
Logical	Accepts only Yes or No boolean values.
Element	An element variable is directly associated with a field in a database table. You will see a variable of the element type, but, in the background, QAD Configurator changes the type so that the value of the variable can be compared to the value in the database. Comparisons require identical data types. QAD Configurator supports Element variable links to two types of entities: Internal Entities, which are defaults within QAD Configurator, and External Entities, which you have to define using External Entity Maintenance.

Variable and Feature Options

Options are predefined values for selection and are available for three types of variables: text, numeric list, and date list.

Here are a couple examples of variable options.

Variable	Variable Type	Options
Cloth	Text	Cotton
		Cotton/Polyester
		Nylon
Cabinet-height	Numeric List	100
		125
		150
		175

When maintaining options for a variable, you can set the default variable option and arrange the order of the variable options so that more frequently chosen options appear towards the top of the list.

Feature options are based on options of the variable from which the feature is created. When maintaining a feature, you can select the variable options you want as feature options or create new options for the feature. You can also set the option and change the order of options in the list. However, these changes you make to feature options do not affect their source variable options. If you select Use Standard Options in Master Group Maintenance, all the features in this master group will use the same options as those of the variables they are created from.

Example The variable Cloth has three variable options (Sunset Orange, Tropical Blue, and Arctic White), the Std Options field has not been set (so feature options can be included), and this variable has been linked to the Sunblind configurable item 9-100-100 to create a feature also called Cloth. The following table shows a possible configuration of using Feature Option Maintenance to change the available options.

Table 2.2
Feature Options

Variable Options		Feature Dependent Options		
		Configurable item: 9-100-100		
Variable	Option	Feature	Options Available	
Cloth	Sunset Orange	Cloth	Sunset Orange	Included
	Tropical Blue		¹	Excluded
	Arctic White		Arctic White	Included
			Royal Blue ²	Added

1. Tropical blue is not a possible cloth for the Sunblind 9-100-100 configurable item and has been excluded
2. The additional option of Royal Blue cloth is unique for the Sunblind 9-100-100 configurable item and has been added.

Sales Configuration Rules

When you have a number of features defined for a configurable item, you may find that the options of one feature have an effect on the choices that can be made for the options of another feature.

Example In the automobile industry, the configurable item could be a family of different models of a type of car. If a customer selects the 1.1 liter engine option, the 5-speed gearbox is not an option that can be selected; if the customer selects the Sport model, alloy wheels are automatically included; if the customer selects the cabriolet model, the sunroof is not a possible option.

In QAD Configurator, you use sales configuration rules to control all these decisions regarding which options automatically include or exclude other options.

Rule Syntax

In its simplest form, a rule states that:

```
IF a specified condition occurs,
THEN a particular conclusion results.
```

The IF statement specifies what the condition is for which you are testing, which is also known as preposition. The THEN statement specifies what the conclusion should be when the preposition is satisfied. You can extend your control by adding an ELSE statement to specify what happens when the IF condition does not occur. The ELSE statement is optional and specifies the alternative conclusion.

```
IF a specified condition occurs,
THEN a particular conclusion results
ELSE an alternative conclusion results.
```

Rules that have as a conclusion the automatic selection of an option are known as inclusions.

```
IF model-type = "sport"
THEN wheel-type = "alloy"
```

The alloy wheels option is automatically included when the customer selects the sport model type.

Rules that have as a conclusion the automatic removal of an option from the available choices are known as exclusions; for example:

```
IF engine-capacity = "1.1"
THEN gearbox <> "5-speed"
```

If the customer selects the 1.1 liter engine, the gearbox can be anything other than 5-speed. The 5-speed gearbox has been excluded.

Rule Statement Formats

The statements that you can use in the basic rule structure of QAD Configurator have three possible formats: basic, advanced, and free format.

- Basic format statements take the form of a simple variable = option; for example: IF operation = manual.
- Advanced format statements take the form of variable = expression; for example: IF width < 0.5 * length.
- Free format statements take the form of a Boolean expression which is either true or false; for example: IF (width > 200 and color = arctic white).

In addition to these statement formats for rules, you can include Boolean operators such as AND and OR in the lines that specify a rule. Using these techniques, you can construct quite complex conditions for the sales configuration rules as in the following example.

```
IF variable 1 > 'value 1'
  AND variable 2 <= 'value 2'
  AND variable 3 = option x
THEN variable 4 = option y
  AND variable 5 <> option z
ELSE variable 6 = 1.5 * 'value 1'
```

The first three lines in the previous example are all part of the preposition and cause QAD Configurator to make a comparison between the specified variables and values or options. The next two lines are the conclusion: they cause QAD Configurator to set the specified variables to include and exclude the named options when the preposition (the IF statement) is true.

The last line is the ELSE statement, which acts in the same way as the THEN statement, but specifies the option to be defined for the specified variable when the preposition (IF statement) is not satisfied.

Example Consider an example of a sunblind where the feature width specifies the width of the sunblind cloth in centimeters, and the feature cloth has three options: Sunset Orange, Tropical Blue, and Arctic White, but only the Sunset Orange cloth can be supplied in widths greater than 200 cm. To build this restriction into the QAD configuration questionnaire logic, you need to create a rule, as follows:

```
IF width > 200
THEN cloth = sunset orange
```

You do not need an ELSE statement in this case. If the cloth width is not greater than 200 cm, the customer can select any of the cloth options, without restriction.

Example The cabinet-height variable can have any value between 50 and 250 centimeters. The cabinet-pane variable can be made of wood, plastic, aluminium, or steel. However, the restriction is that all cabinets with a height greater than 200 cm must have a steel pane, and the steel pane is not available for cabinets less than or equal to 200 cm high. The rule for this restriction could be as follows.

```
IF cabinet-height > 200
THEN cabinet-pane = steel
ELSE cabinet-pane <> steel
```

This specifies that if the cabinet height is over 200 cm, the pane must be steel, but otherwise the pane can be any of the available options except steel.

The rules are the way you can translate the engineering restrictions of your product into limitations regarding customer choice of product configuration.

Sales Configuration Rule Grouping and Application

You can create as many rules as you like, but they do not automatically take effect when you configure a particular configurable item until you apply them to that item. You apply rules by linking them to specific configurable items.

In some situations, a particular set of rules apply and in other situations, another set of rules apply. To avoid the repetitive work of linking rules to configurable items one at a time, and for ease of rule management, you can group rules together and apply them to configurable items all at once.

Within the group, you can use any of the available variables in constructing your rules. The rules that you create in this way are called general rules because they apply generally to the variables you specify, wherever those variables are used. The rules are not initially attached to features or configurable items. QAD Configurator provides separate functions that let you select which of the general rules you want to apply to a particular configurable item. The advantage of using general rules is that you only need to maintain a rule once, and then link it to all the configurable items to which it applies.

You can link general rules to items either directly or through rule groups, which is time-saving. If you know that a number of rules all apply in a particular set of circumstances, you can link these rules together in a rule group. You can then attach that rule group to a configurable item in a single operation, which has the same effect as linking all the rules to the item separately.

When you link a general rule to an item directly, you have the option of making the rule an item-specific rule that applies only to this item, or leaving the rule as a general rule that can also be applied to other items. An item-specific rule is a copy of the general rule, but the general rule remains available to be applied to other items.

An item-specific rule does not need to be based on a general rule. You can also create an entirely new rule using the Maintain button in Item Rule Maintenance.

Before the Analyzer can prepare the questionnaire for correct configuring of the product, you must provide the following information:

- Which rules have been linked individually to the item (both general rules and item-specific rules)
- Which rule groups have been linked to the item
- Which general rules are in each of the linked rule groups

This process is shown in the following diagram.

Fig. 2.1
Linking General Rules and Rule Group Rules to Items

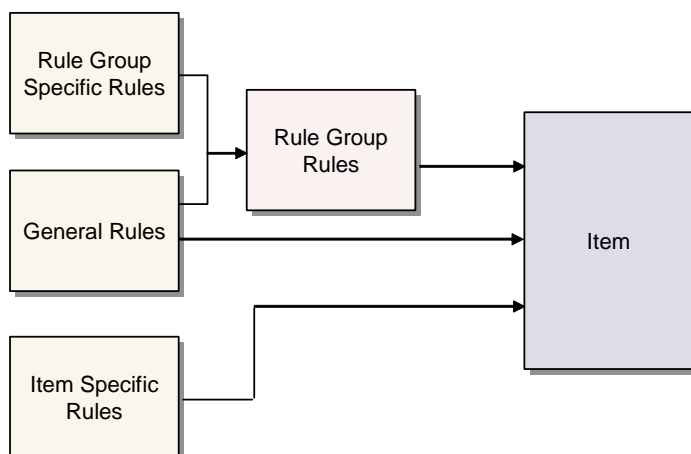

- The first stage covers the definition of general rules, setting up rule group IDs and descriptions, and defining configurable items.
- The second stage covers the process of applying the rules: specifying which rules are linked to a rule group, specifying which rules are linked directly to an item, and specifying which rule groups are linked to an item.
- The final stage covers the running of the Analyzer to process all the rules that now apply to the item.

Analysis of Sales Configuration Rules

Each feature that you define for a configurable item becomes a question in the questionnaire. The rules that you define in the sales configuration process establish the relationships between features. However, before the questionnaire can be used to configure products, the features and rules for each configurable item must be analyzed to determine the interdependencies between the product features. This analysis is performed by the Analyzer, which carries out the following activities:

- Extracts all features used in the sales configuration rules
- Establishes the relationships between the features (builds a question tree)
- Checks for cyclical loops in the sales configuration rules
- Establishes priorities between questions and branches of question trees
- Creates and compiles Progress source code programs to control the questionnaire logic

You need to run the Analyzer after you have done any one of the following:

- Added, modified, or deleted features.
- Added, modified, or deleted rules.
- Changed a parameter in Configurator Control.
- Changed feature sequences.

In any of situations 1, 2, or 3, you must run the Analyzer before you can start the questionnaire. The questionnaire checks if the configurable item has been analyzed, and forces you to analyze the item first whenever something significant has been changed.

In situation 4, running the Analyzer is not required, but optional. QAD Configurator does not automatically offer to analyze the configurable item. However, to make the feature sequence modifications active, you must run the Analyzer manually by selecting the Analyzer function from the product configuration menu.

Feature Relationships

A simple example of a sales configuration rule could state the following:

```
IF variable A = option 1
  THEN variable B = option 2
      AND variable C = option 3
```

You could have another rule attached to the same item stating the following:

```
IF variable C = option 3
  AND variable D = option 4
  THEN variable E = option 5
```

This relationship shows that variable E can be dependent on the options chosen for all of variables A, C, and D. It therefore, follows that the questionnaire must present the questions relating to variables A, C, and D before the question relating to variable E.

The following table shows a development of this example, where the variables are identified by the letters A to G, and the options are represented by numbers. Each row in the table shows the relationship between different variables specified by a particular rule that has been attached to the item. The column on the right shows the relationship in graphic form.

Table 2.3
Feature Relationships

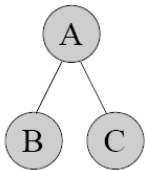
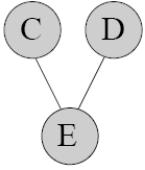
Rule		Description	Graphical Relation
Proposition	Conclusion		
A = 1	B = 2 C = 3	Questions B and C are dependent on the answer to question A, so you must answer question A before B and C can be answered.	
C = 3 D = 4	E = 5	Question E is dependent on the answers to questions C and D, so you must answer questions C and D before E can be answered.	

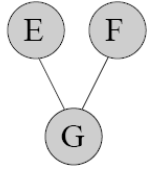
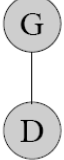
Rule		Description	Graphical Relation
Proposition	Conclusion		
E = 5	G = E + F	Question G is dependent on the answer to questions E and F. (Question E itself depends on question D.)	
G = 6	D = 4	Question D is dependent on the answer to question G, so you must answer question G before you can answer question D.	

When you run the Analyzer for this configurable item, it examines the relationships between the features that have been specified by the rules, and builds a question tree that shows all the dependent links between the features.

Running the Analyzer for the rules in previous table would produce a question tree as in the following diagram.

Fig. 2.2
Question Tree Diagram 1

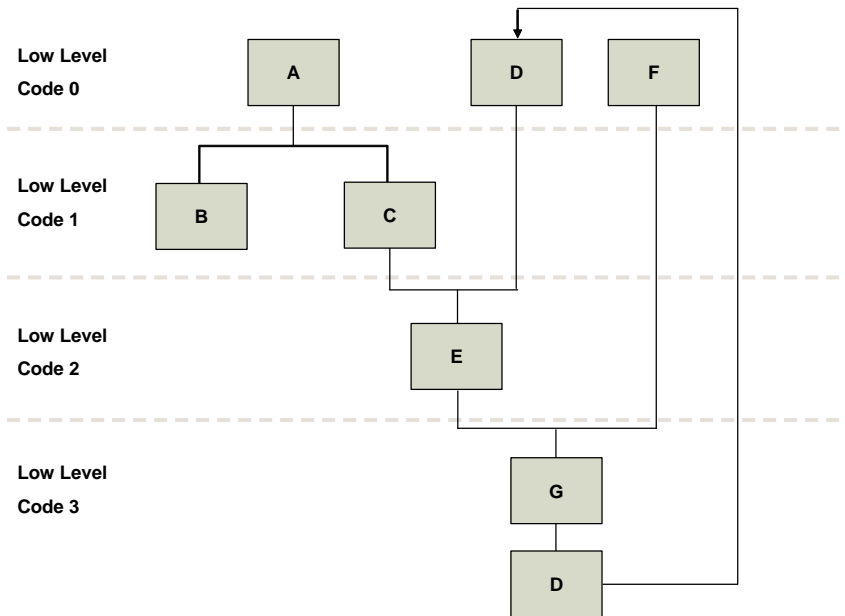

The top row of the diagram shows that variables A, D, and F are independent questions that can be answered without reference to any other features. However, the final rule in the table specifies that variable D is dependent on the answer to question G; the diagram shows that this creates a cyclical loop.

When the Analyzer finds a cyclical loop, it reports the fact in the Analyzer Report. The Analyzer also turns off the field that indicates Configurable Item Analyzed in Configurable Item Maintenance. This makes it impossible to use the configurable item in the questionnaire until the loop has been resolved. To complete the analysis, the Analyzer skips the relationship that gave rise to the cyclical loop (in this example, the dependence of D on G) and continues the analysis process.

When you resolve the cyclical loop by removing the rule that creates the dependence of D on G, the question tree will be the same as in the previous example, but without the lowest level D and its loop back to the top level.

This question tree would correspond to the following list of questions in the questionnaire:

- | Question |
|----------|
| A |
| .B |
| .C |
| D |
| ..E |
| F |
| ...G |

Independent questions are not indented in the list of questions. The independent questions in this list are A, D, and F (as in the question tree). The amount of the indentation shows successive levels of dependence.

The question tree and the question list are dynamic, and change each time a question is answered. In the current example, the following diagram shows the question tree after question A has been answered.

Fig. 2.3 Question Tree Diagram 2

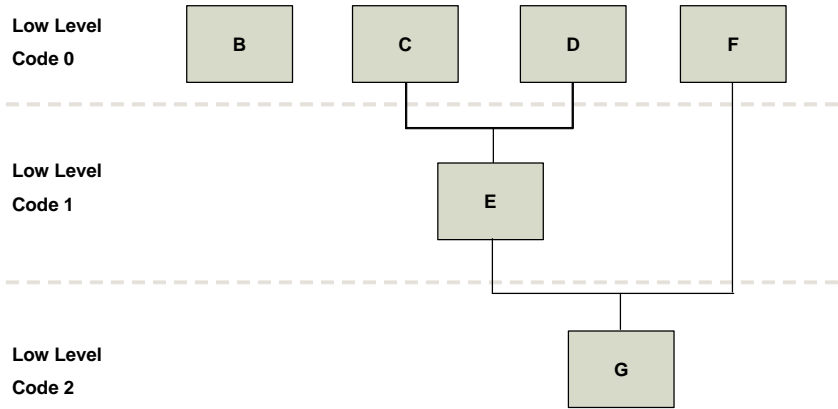

Because question A has been answered, questions B and C now become independent questions, along with D and F. Questions E and G move up a level, but are still not independent because of their relationships with C, D, and F.

This question tree is represented in the question list as follows:

Question
B
C
D
.E
F
..G

This example shows that there are two ways that questions can become independent and therefore, ready for answering:

- Genuinely independent questions that never were dependent on other questions
- Questions that are dependent on other questions that have been answered already, so that the result of the dependent relationship can now be established

In the previous question list, questions D and F are in the first category, while questions B and C are in the second category.

Feature Sequences

Each feature corresponds to a question in the questionnaire that the customer must answer to define the configuration of the product. You can control the sequence in which the questions are asked using Feature Sequence Maintenance, but only within the limits imposed by the logical structure of the interdependence of the features.

Example If one of the questions asks if the customer wants a backup power unit, and another question asks what kind of backup power unit, it would be illogical to ask what kind of unit before asking if the customer wants backup power.

The Analyzer analyzes the relationship between the possible feature options for the product and determines any sequence of questions that must be imposed because of the logical dependence of one feature on another. However, within the limits of the logical constraints, you can determine the order in which the questions are asked. If you specify a sequence that goes against the logical structure, the Analyzer modifies your specified sequence to account for the interdependence.

Example A product includes three features: length, width, and material. The length and width are numeric values within a range, and the material offers a choice of five different materials. However, only two of the materials are available in widths greater than 1.5 meters. Material is, therefore, dependent on the answer to width.

Without any user-controlled sequencing, the Analyzer would present the questions in the following sequence.

```
width
  .material
length
```

The indentation of material indicates that it is dependent on a previous independent feature, in this case, width.

Using Feature Sequence Maintenance, you could manually set the feature sequence as follows.

```
length
material
width
```

When the Analyzer processes the features and rules for your product, it determines that material is dependent on width and modifies the sequence.

```
length
width
 .material
```

The part of the sequence that does not affect the logical structure remains the same as you set, so length is now the first question. However, the Analyzer has changed the sequence of the width and material questions to keep the dependency of the latter on the former.

Multi-Level Analysis

The Analyzer has multi-level capabilities; it can handle configurable item product structures with lower level component items that are themselves configurable items.

When dealing with a multi-level configurable item, the Analyzer performs the following activities:

- Collects all the features and rules on the different levels so that each question occurs only once
- Creates one tree of questions
- Checks for cyclical loops
- Creates one program for the total product structure of the top-level configurable item to control the questionnaire logic for the complete generic product structure

The lower level configurable items in a multi-level generic product structure are automatically analyzed when the higher level configurable item is analyzed. In the following example, when configurable item G1 is analyzed, the configurable item G2 is analyzed automatically as well. You can run the questionnaire for item G2 without first analyzing it separately.

Example The top-level configurable item (G1) includes another configurable item (G2) at a lower level.

Fig. 2.4
Multi-level Analysis

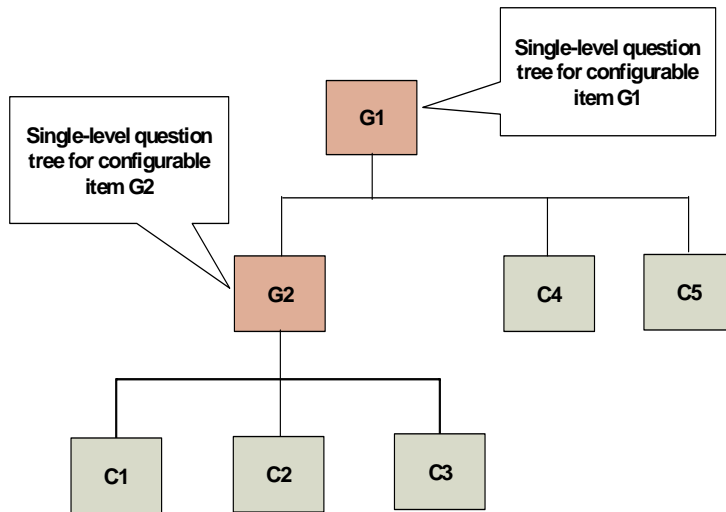

In this example, features F2 and F3 occur for both configurable item G1 and configurable item G2.

When the Analyzer is run for configurable item G1, it also analyzes configurable item G2 and produces a question tree for the multi-level item.

This question tree will be applied when running the questionnaire for the higher level item, G1.

Configuration Keys

When all the questions in the questionnaire are answered for a product configuration, QAD Configurator defines a new configuration used by the Variant Generator, which is a part of the questionnaire, to construct a new variant item, product structure, and routing.

The step from creating a configuration to generating a new variant is only automatic if you have defined a configuration key. You can choose to save the configuration as a description of a product configuration without generating the corresponding variant. It is quite possible, therefore, that some previous use of the questionnaire has produced either a configuration or a variant that matches the specifications of your present customer's configuration requirements.

To avoid configuration and variant redundancies, you can have QAD Configurator check if a configuration already exists. To do this, QAD Configurator uses the configuration characteristics; that is, the answers to the questions. When a configuration already exists, there may already be a variant available with the same configuration description that matches your current customer's requirements. You can then decide whether to use the existing configuration or variant, or to continue with the questionnaire to create a new one.

To find a specific configuration, QAD Configurator needs a key to use as an index. Due to performance considerations and Progress limitations, it is not advisable to include the complete configuration description as the index. In most cases, only a subset of all the configuration elements, that is, the configuration details, is needed to uniquely describe a variant. You can use Configuration Key Maintenance to select the features that uniquely describe a variant.

Note If a feature is added to or removed from an existing configuration key, all unique variant keys for the configurable item must be rebuilt.

Product Configuration Rules

Product configuration rules govern how answers given to questions in the questionnaire are translated into variant items, product structures, and routings.

The output from the questionnaire is a product configuration. When a particular set of answers to the questionnaire produces a unique configuration, QAD Configurator automatically translates it into a variant item if you did not specify a configuration key. When a configuration key is defined, the system lets you choose whether or not to convert the configuration into a new variant item.

When you make this decision, the Variant Product Structure/Routing Generator (which is a part of the questionnaire function) converts the configuration into real components and manufacturing processes. At the end of this process, you will have a new variant product structure, defining the components that are to be included and their respective quantities, and a variant routing, defining the processes required in making the new variant item.

Note You can define in Master Group Maintenance whether a group is to use routings or not. If you select not to use routings, the Variant Product Structure/Routing Generator will not calculate operations.

In order to convert the configuration from the questionnaire into the necessary component selection, quantities, and routings, the Variant Product Structure/Routing Generator requires a set of rules that specify exactly what components and processes should be used.

The features, options, and rules in the sales configuration are used by the questionnaire to generate a product configuration.

When QAD Configurator processes a configuration relating to a configurable item, it must examine every component in the generic product structure, and check to see whether there are product configuration rules that specify whether the component should be included or not.

If there is no rule that applies to the component, it will always be selected.

Example If the customer selects the Sport model and this automatically includes the feature alloy wheels, you will need to define which components from the generic product structure must be included in order to produce this feature:

```
SELECT alloy wheels, qty 5
SELECT sport wheel nuts, qty 20
SELECT sport tyres 185/70 SR13, qty 5
```

The product configuration rules maintenance functions let you define the rules that enable the Variant Product Structure/Routing Generator to generate detailed specifications for new variant items.

Selection and assignment rules are optional. When no selection rule is available for a component or an operation, that component or operation will always be selected. When no assignment rules are available, the values from the generic product structure/routing are used.

The item number definition rule is required for each configurable item to be used to create a variant.

Selection Rules

A selection rule is a Progress expression that must be true or false. When a selection rule is applied to an item, the Variant Product Structure/Routing Generator tests the condition specified in the rule and selects the item if the condition is true.

Example A certain component might only be included in the variant product structure if:

```
color = "Sunset Orange"
and Environment-of-use = "Easy"
```

Another component might be selected if:

```
length * width / 100 > 300
```

Selection rules are similar to the expressions used in sales configuration rules, and make use of variables, options, values, and Boolean operators.

You can use standard rules for frequently used expressions which you want to include in a number of different selection rules.

Assignment Rules

An assignment rule is an assignment of a value to a database element in QAD EA. Although modifying the quantities of components used in variant items is the most obvious use for assignment rules, you can also use them to assign values to any other database element held for the component in the QAD EA `pt_mstr`, `ps_mstr`, and `ro_det` tables; for example:

```
pt_ord_qty = 100 + (safety-stock) / 100
pt_desc1 = "Item with color" + color
```

For a detailed review of all available data elements, refer to the *QAD EA Data Definitions* manual.

Item Number Definition Rules

An item number definition rule defines how to build up the new variant item numbers. When you create a new variant item, you will need to generate a unique item number for it. By defining a rule for each configurable item, you enable the Variant Product Structure/Routing Generator to standardize the structure of the variant item numbers it creates from that configurable item.

In the item number definition rule, the structure of the item number consists of one or more of the following components:

- Current configurable item number: position From/To
- Master configurable item number: From/To
- Feature: position From/To
- QAD EA database element: position From/To
- Fixed text
- Character
- Alphanumeric Sequence: length, multiplier, and start value
- Numeric Sequence: number of digits, start value, and multiplier

You can combine these components in any order you want to create new variant item numbers. The maximum number of positions you can use is 18. With the exception of the alphanumeric and numeric sequence component, you can use the individual components more than once in an item number definition. For the numeric sequence and alphanumeric sequence components, you can add them only once—you can add a numeric sequence and an alphanumeric sequence.

Example If your master configurable item number is 9-100-100, and you specify in the item number definition rule that the item number is to include the master configurable item number, followed by a character (-), followed by a numeric sequence number of three digits, starting at 001, multiple 1, you will generate successive variant item numbers as follows:

```
9-100-100-001
9-100-100-002
9-100-100-003...
```

Dynamic Update of Routing Operation Comments

Answers to the QAD Configurator questionnaire can be used to dynamically update the comments for operations in the variant routing.

Routing Maintenance in QAD EA has a Comments field. When this is set to Yes, you can add comment text that is printed on shop floor documents for work orders for the item. Sometimes it can be very helpful to inform the shop floor of one or more answers from the questionnaire, such as a situation in which items have to be made to the right dimensions. To include information from questionnaire answers, you can refer to the QAD Configurator feature name in the comments of the applicable operation by putting the name of the feature in brackets []; For example, when length, width, and color are QAD Configurator features:

```
Comments Operation 10 (Generic routing):
Please be aware that the required specifications for the product are:
Length = [length]
Width = [width]
Color = [color]
```

As soon as a new variant routing is created, the customer's selected values (answers) for these questions are used to fill out these fields. In the previous example:

```
Comments Operation 10 (Variant routing):
Please be aware that the required specifications for the product are:
Length = 120
Width = 80
Color = white
```

You do not need to set up anything in QAD Configurator to make this work. It requires the definition of the routing comments for the relevant operations in the generic routing in QAD EA.

Cost Roll-Up

The system uses the existing routing cost roll-up and product cost roll-up routines in QAD EA to calculate the costs of manufacturing an item. In order to do this, QAD EA takes into account the various types of costs that appear in the product structure of the item. Because QAD Configurator adds the product structure of the items that you configure to the QAD EA database, the cost roll-up functionality is incorporated in QAD Configurator as well. Calculating the costs for an item involves adding the following five types of costs:

- Material costs

- Labor costs
- Burden costs
- Subcontract costs
- Overhead costs

The roll-up of the total costs consists of one product structure roll-up and one or more routing roll-ups.

When a routing roll-up has been completed on every level in the product structure and a product structure roll-up has been done for the top level item, the lower level costs and this level costs of this top level item can be added. They constitute the total costs of the top level item.

For more information on product costing, see either the Costing chapter in *User Guide: QAD Financials* or *User Guide: Costing*, depending on your product version.

Element Roll-Up

When the Variant Product Structure/Routing Generator creates a new variant, the process normally includes the element roll-up calculations. You can use the Element Roll-Up function subsequently to execute a calculation to roll up selected data elements for a variant; for example, if the original rule has been changed. The function operates only on non-cost element related data elements, such as lead time or weight, to produce figures for the total lead time or total weight of the variant product.

Before you can run Element Roll-Up, you must first define the element roll-up rules for configurable items. You do this using Element Roll-Up Rule Maintenance. See “Maintaining Element Roll-Up Rules” on page 113.

Depending on whether you want to roll-up component-related elements or routing-related elements, you can use Element Roll-Up Rule Maintenance to compose roll-up rules from either of the following sources:

- Product structure (ps_mstr) and/or item data (pt_mstr), both using either master data or component data
- Routing data (ro_det) and/or Work Center data (wc_mstr)

The following diagram illustrates the element roll-up process.

Fig. 2.5
Element Roll-Up Process

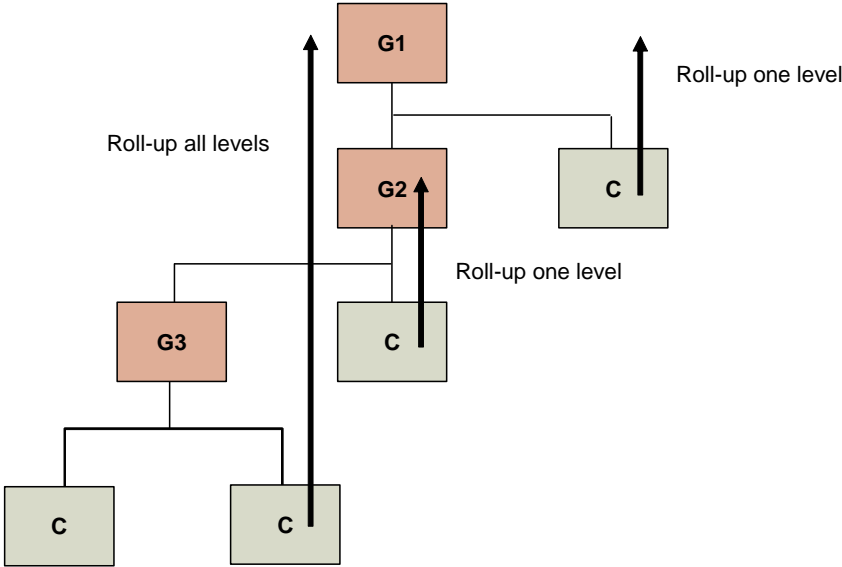

Roll-up rules can consist of simple expressions containing only one element, which are called basic rules, or complex expressions containing more than 1 element, which are called advanced rules.

Example A basic rule that rolls up the production lead time of all components could take the following form.

$$\Sigma \text{ pt_mfg_lead}$$

Example A more complex rule could take the following form.

$$\Sigma (\text{ component:pt_abc_qty} / \text{ master:pt_dec01}) * \text{ ps_qty_per}$$

Within Element Roll-Up Rule Maintenance, for a basic rule, you select the single element to roll up from a drop-down list. For an advanced rule, you compose the expression for the rule in an editor window. An advanced rule can contain any of the elements listed in the following tables.

Product Structure Roll-Up

pt_mstr	The elements of the master item (variant item number) can be used. By using the element name without prefix or by adding the prefix master, the values of the master item (pt_mstr) are selected. The elements of the component item (component item number) can be used. By adding the prefix component to the element name, the values of the component item (pt_mstr) are selected.
ps_mstr	The elements of the product structure (ps_mstr) can be used.

Routing Roll-Up

pt_mstr	Only the elements of the master item (variant item number) can be used (no prefix or prefix master).
wc_mstr	The elements of the work center can be used.
ro_det	The elements of the variant routing (variant routing number = variant item number) can be used.

You cannot use variables, features, or options in element roll-up rules, and only one roll-up rule can be defined for each master item element.

Cross Validation of Rules

Because the sales configuration data and the product configuration data is maintained separately, it is necessary to check that there are no discrepancies between the two sets of data for particular configurable items. For example, you may have included variables in the product configuration rules that are not used in the features of the configurable item. This can give rise to unknown answers in the questionnaire, and a failure to select a component.

You can use the Cross Validation Analyzer to check if the product configuration rules and rules match the sales configuration data (features and rules). This analyzer detects any discrepancies between the two modules and produces a report.

The Cross Validation Analyzer is a reporting function only. It does not correct any errors that it finds. To do that, you must use the standard QAD Configurator maintenance functions. For example, you might add a feature to the configurable item using Feature Maintenance, or modify a product configuration selection rule.

The Cross Validation Analyzer has multi-level capabilities: it takes into account all lower level items and components of the selected configurable item. The Cross Validation Analyzer checks for any inconsistencies in the model from the current configurable item downwards. It not only reports errors it finds during the cross validation of the current configurable item, but also reports inconsistencies that may lead to errors during a cross validation of a lower level configurable item.

What the Cross Validation Analyzer Checks

You control what the Cross Validation Analyzer checks by means of the selection flags in the Cross Validation Analyzer main window:

- Configurable item components only
Only the components that are one level lower than the configurable item are checked, not the components on lower levels.
- Variant assignment rules
The variables used in the assignment rules must be valid features for the relevant configurable item, or higher level items. Features of a higher level configurable item are also available on lower levels, if the relevant higher level configurable item is the configurable item for which the Cross Validation Analyzer is run, or is a component of that configurable item.
- Rule syntax
The Cross Validation Analyzer checks the syntax of all selected rules by compiling the code using the Progress Compiler.
- Variant item numbers
Checks if a variant item number exists for every configurable item in the product structure. QAD Configurator cannot create a variant of the current configurable item if it does not have a variant item definition rule to specify the number to be used when storing the new variant item data.
- Features

This routine checks if all features are used properly given the configurable items in the generic product structure and the features that are defined for each of them.

Example of Using the Cross Validation Analyzer

The following diagram shows a schematic representation of an example configurable item structure. Items annotated with (G) are configurable items.

Fig. 2.6 Example Configurable Item Structure

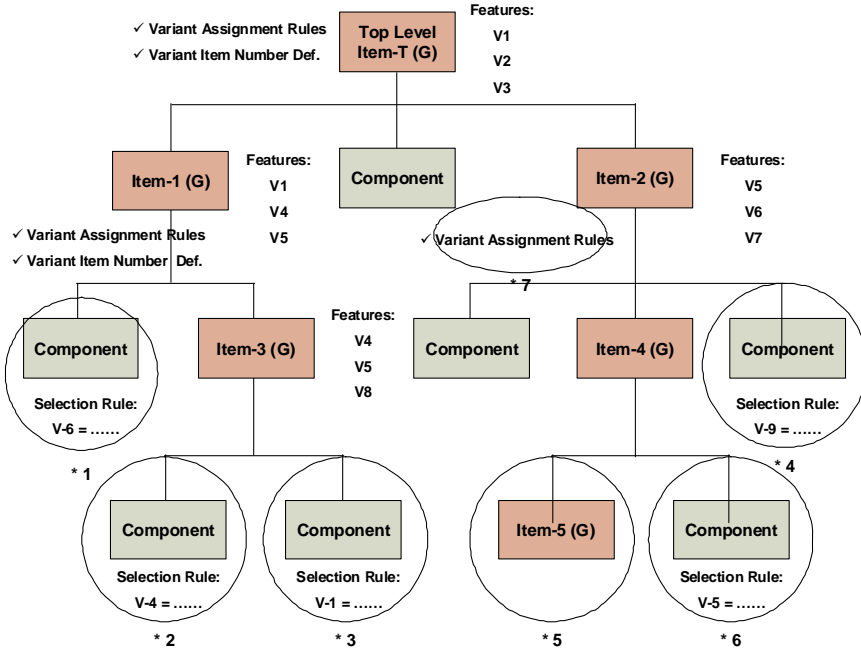

The paragraphs below show example checks and the warnings or errors reported for the situations numbered *1 to *7 in the diagram, when analyzing the top level configurable item.

- 1 Warning/Error: component [name] variable V-6 not defined as feature for item [Item number].
Feature V-6 is defined for configurable item Item-2, which is a component item of the top level Item-T. As all features of all configurable items in the product structure are collected into the highest level (and as a result the selection rules on every level can be verified), this does not cause an error situation when the top-level configurable item is used to create a variant. However, if the Item-1 configurable item is used as the top-level item to create a variant, an error situation occurs.
- 2 Correct.
The V-4 variable is defined as a feature for the next higher configurable item Item-3, so the selection rule can always be verified.
- 3 Warning/Error: component [name] variable V1 not defined as feature for item [name].
The V-1 feature is not defined for configurable item Item-3, but for a higher level configurable item Item-1. When creating a variant of the top-level configurable item or of Item-1, this will not cause difficulties, but when creating a variant of Item-3, QAD Configurator cannot verify this selection rule and an error occurs.

- 4 Error: Variable V-9 not defined as feature for [top-level item name].
The V9 variable is used in the selection rule but is not defined as a feature for any of the configurable items in the product structure.
- 5 Warning/Error: Broken Chain of configurable items.
The Item-4 parent item is not a configurable item. As a result Item-5 will be handled as a standard item and all its components will be selected. Defining Item-5 as generic is, therefore, meaningless. Defining lower level items as generic requires a linked chain of configurable items up through the higher levels.
- 6 Warning/Error: Selection rule found for non generic component item or assignment rule found for non generic component item in the case of a assignment rule.
The Item-4 parent item is not a configurable item. As a result, every (generic) component on a lower level will automatically be selected into the variant product structure. Selection rules on lower levels are, therefore, meaningless. Selection rules are only active if the parent item of the component is a configurable item.
- 7 Error: No variant item number definition found for configurable item.
It is not possible for QAD Configurator to generate a new variant in QAD EA for the top-level configurable item since it does not know how to store its findings.

Cross Validation Analyzer Report

Cross Validation Analyzer Report is displayed on the screen in the standard output window and can be printed using the standard print routine.

Questionnaire

Questionnaire is the front end guided selling module of QAD Configurator that lets you configure products for specific customers by selecting product feature options in the form of a questionnaire. Product configurations resulting from the questionnaire can be saved and used to create new variant items.

Questionnaire can be started from the QAD Configurator menu or automatically launched from Sales Order Maintenance (7.1.1) or Sales Quote Maintenance (7.12.1) when you enter a configurable item in the order line.

When you configure a product for a specific customer in Questionnaire, you are presented with a list of questions that correspond to the product's features. As you answer each question, you select options for each feature of the product. When you finish all the questions, you have a combination of answers or feature options that is called a configuration in QAD Configurator. Each product configuration can be saved and reused later.

When a firm order is placed for a new product configuration, you convert the configuration to a new variant item, with its own item number, variant product structure, and if required, variant routing.

Questionnaire Questions

Each question corresponds to a configurable product feature and each option in a question corresponds to a feature option. How questions are generated and how you can answer them are determined by questionnaire-related sales configuration data including feature and option sequence, feature and option characteristics, as well as inclusions, exclusions, and interdependency rules.

The main types of questions recognized by QAD Configurator are as follows:

- Foreground questions, which require answers from the customer.
- Background questions, which can be answered by the customer, but do not need to be. If no answer is supplied, the default is used, even if there is no rule to cover the question.
- Temporary questions, which are usually answered by QAD Configurator calculating values according to the rules.

When you customize the question display, you can select which levels and types of question are shown in the display, and how many levels should be displayed. If you select only one level, only the questions currently ready to be answered are displayed; if you select two or more levels, that number of levels of dependent questions is also displayed.

Configurations

When you have finished answering the questions in the questionnaire, QAD Configurator generates a uniquely identified configuration. The configuration is an intermediate stage between answering the questions and generating the new variant item and its product structure and routing. QAD Configurator can automatically check if a configuration already exists, thus preventing sales personnel from configuring the same item twice.

QAD Configurator records each configuration that is generated by the questionnaire. Whenever a configuration is converted into a variant item, the new variant is assigned a unique item number according to the item number definition rule defined for the configurable item. Consequently, when you want to use the questionnaire to define a product configuration for a customer, you may find that the required configuration has already been defined, either as a configuration, or else as a variant item.

To avoid variant redundancies, you can let QAD Configurator check if a configuration or variant item already exists that matches your required configuration. To do this, QAD Configurator uses the configuration key of the configurable item, which specifies what combination of features uniquely describes a variant. If QAD Configurator finds that a configuration or a variant already exists with the same configuration description, you can then decide either to use the already existing configuration or variant, or to continue with the questionnaire and create a new configuration and variant.

Pricing

When you define a configuration in the questionnaire, Configurator calculates its price in real time.

In many situations the price of a configuration is equal to the sum of the prices of its components. Now suppose that each component is only chosen if a certain option is selected as an answer (a one-to-one relationship between the options and the components). Then instead of associating a price with the component you can also associate a price with the relevant option and sum the prices of the options. This is the method Configurator uses.

To link a price to an option, you must define a pricing part for that option. Configurator will use the price and price lists (if any) of this pricing part to find the best net price and the best list price of the feature option. Any item can serve as a pricing part.

If there is a one-to-one relationship between the options and the components, all Configurator has to do is to sum the prices associated with the selected options. But if selecting a certain option leads to selecting more than one unit of some component, you may want to incorporate the price of this component that same number of times in the price of the configuration. How you can do this depends on the type of the feature to which the option belongs.

For numeric and numeric list features you can tell Configurator to interpret the value of this feature as the number of units of the component. You do this by selecting the Quantity Based check box in Variable Maintenance or Feature Maintenance. If you do not select this check box Configurator will act as if only one unit of the component is added to the configuration.

For all other types of features the Quantity Based check box is not available, but in these cases you can use a pricing rule. This is a special type of rule in which the pricing quantity (pricing_qty) attribute of the feature is set. Configurator interprets the value of this attribute as the number of units of the component. If you do not define a pricing rule a quantity of 1 is used.

The general case shown so far can be extended very easily. To see that the pricing functionality offers many more possibilities for defining the price of a configuration, you should realize that:

- The pricing part of an option does not have to be the component that is selected if you choose that option. This means that you can associate with an option any price you want, by specifying a dummy item and using that item as a pricing part for the option.
- If a pricing part is not the component that is selected when you choose an option, then the number of units is not the number of units of the actual component, but the number of units of the item that serves as the pricing part. In fact, the pricing quantity is only used to help you find a price in a price list and thus it does not even have to refer to a number of units that is selected in the variant product structure. This means that you can force the price of a configuration to go up when a certain option is selected, even if you do not want the choice to result in the selection of a component.
- If one or more components are always selected (independent of the answers given) then you can define a separate price or separate price lists containing the total price of this collection of items and link these to a dummy item. Then you can use this dummy item as a pricing part and make sure that its price is always incorporated in the price of the configuration, for instance by having a rule that makes sure that the relevant option of this (dummy) feature is always selected.
- If choosing a certain option means that more than one different component is selected, then you can create a new price or new price lists containing the prices of the relevant collection of components and link these to the pricing part that you associate with the option.

Apart from a pricing part and a pricing quantity you also need to provide a pricing unit of measure to the engine that calculates the best prices. The pricing quantity of (a pricing part associated with) an option is always expressed in terms of the pricing unit of measure that you enter in

Configurator. For instance, if the unit of measure for an item or in a price list is grams and the unit of measure as entered in Configurator is kilograms, then a pricing quantity of 2 in the questionnaire means a quantity of 2 kilograms. Because Configurator calls the standard QAD EA pricing engine the alternate unit of measure, the conversion factor, and the prices and price lists for the original unit of measure are used in the normal way to calculate the price of 2 kilograms in the questionnaire.

In order to enter pricing part, quantity based, and unit of measure correctly, you should first enter the data in Variable Maintenance and Feature Maintenance. In general the data as entered in Feature Maintenance is used, but there are two exceptions to this rule:

- If Std Options is selected in Feature Maintenance the data from the variable option is used.
- If the feature is a logical and the answer in the questionnaire is equal to no, then Configurator uses 0 as the price for the feature. If the answer is yes then Configurator uses the pricing information as specified in Feature Maintenance.

Note The price of the configuration as shown in the questionnaire is always the price of one unit of the configuration.

QAD Configurator Workspace

Workspace Overview 32

Gives context for how Configurator relates to other QAD programs.

Accessing QAD Configurator Functions 32

Describes different methods of accessing Configurator functions and illustrates the Configurator process map.

Application Toolbar 33

Describes the functions of the Applications Toolbar.

Selecting a Master Group 33

Explains how to identify and select different master groups.

Maintaining Records 33

Explains how to modify records by creating, viewing, editing, cycling through, or deleting them.

Editing Comments 35

Explains how to use the Comment Editor toolbar.

Using the Rule Assistant 35

Explains how to use the Rule Assistant to compose valid rules.

Using Browsers and Browse Collections 35

Describes how to use the configuration browse, view the Variables and Features browse and Configurations browse collections, and customize the configuration browse.

Workspace Overview

Integrated with QAD EA, QAD Configurator is embedded in the application area of the QAD .NET user interface and therefore is consistent with the rest of the QAD EA applications in terms of look and feel and navigation. For information on the .NET user interface, see *User Guide: QAD User Interfaces*.

This section describes some common UI features specific to QAD Configurator.

Accessing QAD Configurator Functions

You can access QAD Configurator functions by using either the Menu Search field or the menu tree in the Applications pane in the QAD .NET user interface.

After you install QAD Configurator, QAD Configurator functions are grouped under Customer Management|Configurator by default in QAD 2008.1 Enterprise and later. For earlier versions of QAD EA, QAD Configurator functions can be found under Distribution|Configurator.

You can also access Configurator functions using Configurator process maps. By linking related subprocesses and activities together in the form of interactive workflow diagrams, process maps tie up all the functions you need to launch sequentially in order to perform specific tasks. You can drill down a process map by clicking a subprocess icon to access lower-level functions.

The Configurator process maps are integrated into the Supply Chain View and Vertical Industry View process maps in the QAD .NET UI 2.8.2.

Fig. 3.1
Configurator Process Map

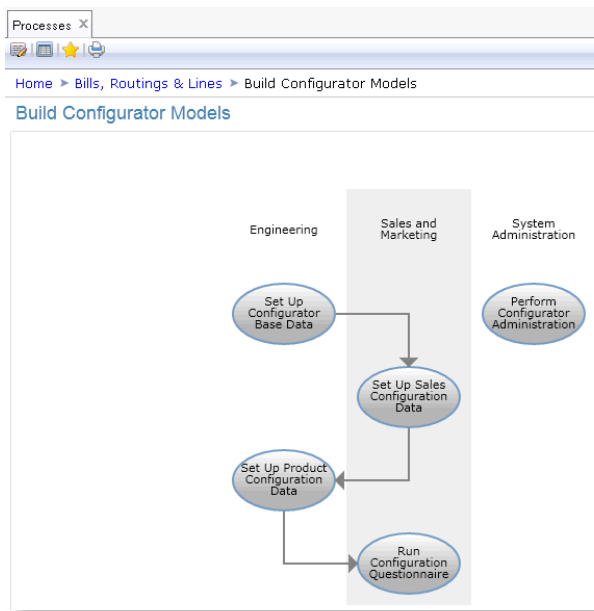

The Questionnaire module is automatically launched when you select a configurable item in the order line in Sales Order Maintenance (7.1.1) or Sales Quote Maintenance (7.12.1) in the QAD EA .NET UI environment.

Application Toolbar

Like other QAD EA applications, QAD Configurator's application toolbar resides at the top of the application area and provides access to the most common functions.

Fig. 3.2
QAD Configurator Application Toolbar



Action. Use the following action commands to cycle through records in a record maintenance screen:

- First Record
- Previous Record
- Next Record
- Last Record

Print. Print out the current screen.

Print Preview. Preview the current screen before printing.

Delete. Delete the current record on a record maintenance screen.

Note The Delete button is only enabled in edit mode.

Group. Displays the current master group. You can specify another master group by clicking the Browse button next to it.

Selecting a Master Group

When executing QAD Configurator functions, you must make sure that you are in the right master group. Your current master group is displayed on the right of the toolbar and all the data you work with is associated with it.

To specify another master group:

Click the Browse button next to the current master group on the toolbar and select the group you want from the browse window.

Maintaining Records

Record maintenance functions such as Variable Maintenance, Question Type Maintenance, and Master Group Maintenance let you create, view, edit, or delete records in a consistent manner.

Fig. 3.3
Example of Record Maintenance Functions

To create a new record:

- When you first access a record maintenance function, directly enter a new record ID in the record ID field, which is typically the first field on the screen, then press Enter or Tab to edit the new record.
- When you have a record opened or created for editing, click the New button in the bottom-right corner of the screen or directly enter a new record ID in the record ID field, which is typically the first field on the screen, then press Enter or Tab. The system will ask you whether you want to save the current record.

To view a record:

Enter an existing record ID in the record ID field or click the Browse button next to the record ID field and select an existing record from the browse window. The specified record is loaded for viewing.

To edit a record:

Enter an existing record ID in the record ID field or click the Browse button next to the record ID field and select an existing record from the browse window; then press Enter or Tab to enter edit mode.

To cycle through records:

Use the Action commands on the toolbar or place the cursor in the record ID field and press the Up and Down arrow keys to navigate through records.

To delete a record:

When the record is in edit mode, click the Delete button on the toolbar.

Note The Delete button on the toolbar is disabled in record view mode.

Editing Comments

Most record maintenance functions in QAD Configurator provides a Comment tab that lets you create additional notes in different languages.

Note You can only add one comment for each language.

Fig. 3.4
Comment Editor

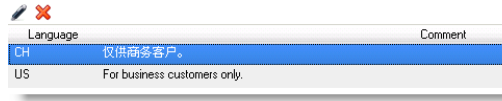

To add or edit a comment:

Click the Edit button on the Comment Editor toolbar; then select a language and enter text in the Comment box.

To delete a comment:

Select the comment in the list and click the Delete button on the Comment Editor toolbar or press the Delete key.

Using the Rule Assistant

When you edit rules in most rule maintenance functions, you can use the Rule Assistant to assist you in composing valid rules.

Fig. 3.5
Rule Assistant



Click the Down arrow to expand the Rule Assistant panel. To add an element to the Rule box, select it from the drop-down list and click the Plus sign + to the right.

Note The available fields and options may vary depending on the type of rule you are editing.

Using Browsers and Browse Collections

Use the following menu-level browsers and browse collections to easily view, filter and sort configurations, variables, and features:

- Configuration browse
- View Variables and Features browse collection
- View Configurations browse collection

- View Configuration Details browse collection

Fig. 3.6
Configuration Browse

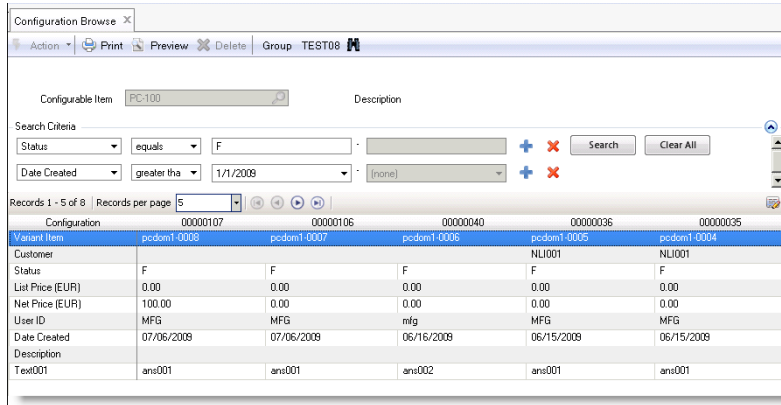

In a browse collection, a main browse drives the fields selected in the other browses and programs. The QAD .NET UI displays the other browses and programs in the lower part of a horizontal split-screen, with the main browse located in the upper part.

Fig. 3.7
View Configurations Browse Collection

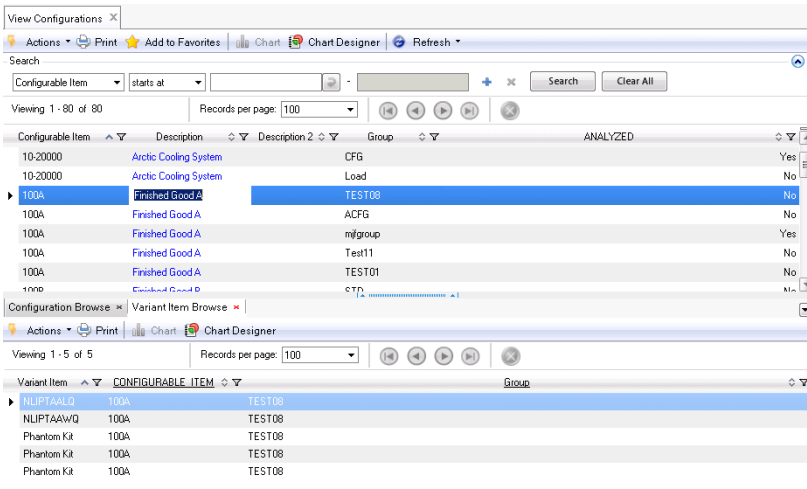

The View Configurations browse collection includes a Configurable Item browse with a Configuration browse and a Variant Item browse.

If you click on a record in Configurable Item, the associated browses automatically have the data for that selected item. You can just click on the Configuration Browse tab to see existing configurations for that configurable item, or click on the Variant Item Browse tab to see existing variant items created from it.

Fig. 3.8
View Variables and Features Browse Collection

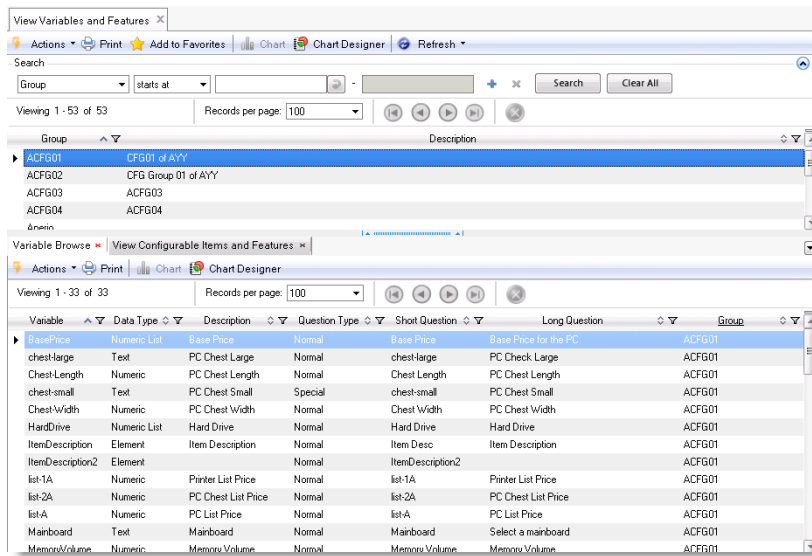

The View Variables and Features browse collection includes a Master Group browse with a Variable browse and a View Configurable Items and Features browse collection.

If you click on a record in Master Group, the associated browses automatically have the data pertaining to that group. You can just click on the Variable Browse tab to see existing variables under the group, or click on the View Configurable Items and Features tab to see configurable items and related configurations and variant items.

Fig. 3.9
View Configuration Details Browse Collection

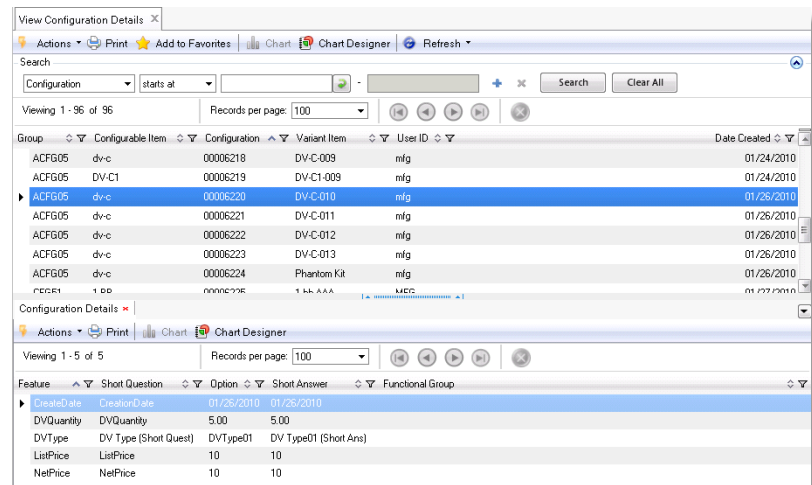

The View Configuration Details browse collection includes a View Configurable Items browse and a Configuration Details browse.

If you click on a record in View Configurable Items, the associated browse automatically has the data pertaining to that item.

Customizing the Configuration Browse

To customize the Configuration Browse, click the Customize icon beneath the search box to the right. You can specify whether or not to show temporary questions and background questions and whether to display long or short questions in the Configuration Browse.

Note You cannot hide temporary or background questions when they are used as filter criteria in the search box.

Fig. 3.10
Customize the Configuration Browse

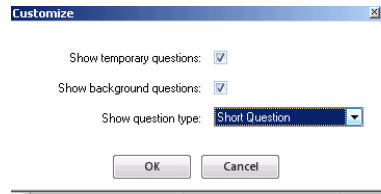

Configurator Setup

***Setting Up Data in QAD EA* 40**

Explains how to set up data in QAD EA with sections on creating items, product structures, and generic routings.

***Setting Up QAD Configurator* 42**

Explains how to configure system settings, addresses master groups and how to maintain them, and explains how to maintain configurable items, copy configurable item data, and maintain external entities.

Setting Up Data in QAD EA

QAD Configurator is designed to work with QAD EA. It does not maintain a separate database of item data, product structure, or routings. To use the functions of QAD Configurator, you must define which items in QAD EA are to be used as configurable items by QAD Configurator; QAD EA does not itself use the term configurable item. This then gives access to the relevant product structures as generic product structures and the relevant routings as generic routings.

QAD EA must contain all the item, product structure, and routing details for the products you intend to configure using QAD Configurator.

If you are setting up QAD Configurator to configure products that already exist in the QAD EA database, you need only ensure that all the item details, product structures, and routings are present in QAD EA and represent current information.

If you are setting up QAD Configurator to configure a new product range, you will need to create the following:

- All the item details in QAD EA Item Master Maintenance
- All the bills of material in QAD EA Product Structure Maintenance
- All the possible operations in QAD EA Routing Maintenance

If you did not disable the item-site data creation feature during system installation, you need to create item-site records for all the sites in which variant items are manufactured or sold using the following QAD EA functions:

- Item-Site Inventory Data Maintenance (1.4.16)
- Item-Site Planning Maintenance (1.4.17)
- Item-Site Cost Maintenance (1.4.18)

You may also need to create or modify records of other QAD EA elements, such as sites and work centers relating to the product range you want to configure.

Note The item details and the product structure details are necessary for QAD Configurator; you must set these up in QAD EA before you can use QAD Configurator. However, use of generic routings is optional in QAD Configurator. You can set up QAD Configurator so that it does not generate variant routings when you configure a variant item. If this is the case, you do not have to set up the generic routings in QAD EA for your product family.

When all the correct product-related data is present in QAD EA, you can define the parent item for the product as a configurable item in QAD Configurator. This is necessary as the first step in the sales configuration process for the product, because all the QAD Configurator programs make reference to the configurable item.

The following figure illustrates the relationship between QAD EA and QAD Configurator.

Fig. 4.1
Relationship between QAD EA and QAD Configurator

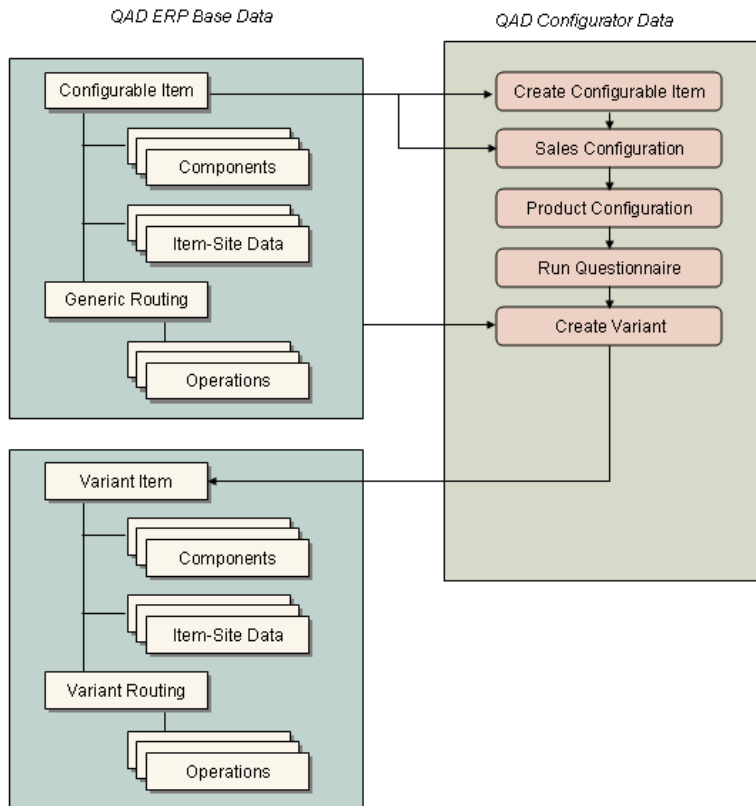

The parent item, generic product structure, and generic routing information from QAD EA is used in QAD Configurator by way of the configurable item. When you configure a product in QAD Configurator to create a variant item, the variant product structure and the variant routing you create can be used by QAD EA to manufacture the configured product.

The QAD EA functions used during setup include the following:

- Creating items using Item Master Maintenance
- Creating item-site records using Item-Site Inventory Data Maintenance (1.4.16), Item-Site Planning Maintenance (1.4.17), and Item-Site Cost Maintenance (1.4.18)
- Creating generic product structure using Product Structure Maintenance
- Creating generic routings using Routing Maintenance

Creating Items

All the items in the generic product structure for the products you want to configure must exist in QAD EA before you start using QAD Configurator to configure products. If you are setting up QAD Configurator to configure products that already exist in the QAD EA database, make sure that all the item data is correct and up-to-date. If you are setting up QAD Configurator to configure a new configurable item, you must create all the related item records in QAD EA first.

Refer to the QAD EA documentation for details on creating and modifying item details in Item Master Maintenance (1.4.1).

Creating Generic Product Structure

You must ensure that the multi-level or single-level generic product structures for the products you want to configure exist in QAD EA, including all the possible components that could be configured for a product. You do this using Product Structure Maintenance (13.5).

Refer to the QAD EA documentation for details on creating and modifying product structure details.

Creating Generic Routings

QAD Configurator requires the existence of the items and generic product structures in QAD EA for the products you want to configure, but the generic routings are optional. However, if you intend to use QAD Configurator to configure routings as well as variant product structures, you must ensure that the generic routings exist in QAD EA, including all possible processes that could be required for the manufacture of any configurable variant item. You do this using Routing Maintenance (14.13.1).

Refer to the QAD EA documentation for details on creating and modifying generic routing details.

You may need to create departments, work centers, and standard operations before you start creating the routings.

Setting Up QAD Configurator

Setting up QAD Configurator involves the following general steps:

- 1 Configure Configurator system settings
- 2 Set up master groups
- 3 Maintain configurable items
- 4 Copy configurable item data (optional)
- 5 Maintain external entities (optional)

Fig. 4.2
Configurator Base Data Setup Process

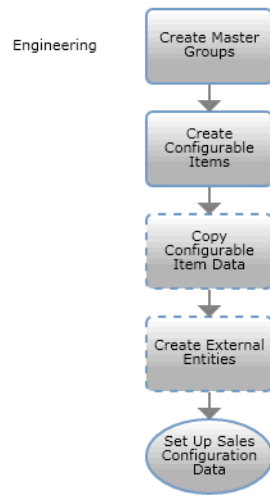

Configuring System Settings

Use Configurator Control to configure the QAD Configurator system settings.

Fig. 4.3
Configurator Control

AppServer Questionnaire Directory. Specify the directory on the AppServer where files used by the .NET UI questionnaire will be stored. These files are generated by the Analyzer and contain the inclusion and exclusion logic for features and options. You must map the remote directory on the AppServer to a local drive first.

AppServer Variable Directory. Specify the directory on the AppServer where files created by Variant Product Structure Generator will be stored and used by the .NET UI questionnaire. These files contain the variant product structure and variant routing information. You must map the remote directory on the AppServer to a local drive first.

SQ/SO Maintenance. Use these options to select the type of entry that QAD Configurator will use to store sales quote and sales order information.

Select Product Structure if you want the system to create item product structures when creating configurations; otherwise, select Off.

Pegging for Re-analyze. If you select the Pegging for Re-analyze check box, QAD Configurator will force re-analysis of the relevant configurable item and all higher level configurable items whenever a rule is changed at some level of the product structure. QAD Configurator enters No in the Analyzed field of the Configurable Item Maintenance window for the affected configurable items.

This check box is normally deselected only when you are testing temporary rule changes and want to save excess analysis time.

WebSpeed URL. Enter the WebSpeed Workshop URL in the following format:

```
http://WebSpeedServerHostName/cgi-bin/wspd_cgi.ksh/WService=
WebSpeedBrokerName
```

Static Web Context URL. Enter the URL address in the format of `http://server_ip/alias_name` where the scripts, images, and styles folders are published. `alias_name` is the Apache server Alias configuration that points to `ConfiguratorWebSpeedInstallDir/cpd/htdocs`

Web Connection Timeout. Specify the amount of time allowed to try to connect to the web server before the system stops trying.

Web Configuration Path. Specify the path where the `AppServerConnection.xml` file is to be stored. You must first create the directory for storing the configuration file under `ConfiguratorWebSpeedInstallDir` and give it read and write permissions.

About Master Groups

When you have a large quantity of manufacturing data in your QAD EA database, you can simplify data management and access in QAD Configurator by classifying the data into different master groups based on product family or product type. Master groups are not domain-specific.

When you have several master groups, always make sure you are in the right master group when you work with such data as configurable items, variables, features, and all kinds of rules. Data created in one master group exclusively pertains to that group and can not be accessed from other master groups.

For example, if you have created a variable Humidity in the Small Business master group, it can not be accessed in the Consumer master group, unless you create another one in the Consumer master group as well. Likewise, all the sales configuration rules and product configuration rules you set up in the Consumer master group only apply to configurable items in that group, not others.

QAD Configurator provides a built-in master group STD and it can not be deleted.

Example The arctic cooling system is a part of a product family covering industrial and domestic heating, cooling, and humidity control equipment. Despite major differences in the component parts included in its generic product structure, many of the variables are common to the entire range:

- Electrical voltage
- Usage, from domestic through heavy industrial

- Paint color for the equipment housing

The rules set up to control the configuration of products in this range will in many cases be very similar. Therefore, you can set up a master group called ENVCON (Environmental Control) to include all these products.

Now, whenever you work on sales configuration activities for any of the products in this range, you first make sure that you have selected the ENVCON group. In this way, all the variables that have already been used within this group are available to you.

When you create a new group, you can also set up various defaults and settings that control the way QAD Configurator operates within this group only. For example, you can set up the default number of digits and decimals that are used for numeric variables and features created in the group; you can select a default rounding method; you can specify whether single-level or multi-level product structures are used; and you can specify whether you require QAD Configurator to generate variant routings for products configured in this group.

This lets you customize the way QAD Configurator operates in a different manner for each group of products. If variant routings are required for some products but not for others, you can create one group with the routings option selected and another with it deselected. You can create as many different groups as you need.

You create and maintain groups using Master Group Maintenance.

Maintaining Master Groups

Use Master Group Maintenance to create, view, edit, or delete master groups.

Master groups are used to simplify and streamline the configuration process by categorizing product data based on products' common characteristics and defining rules and default settings associated with configurable item selection and variant item creation for a group of products.

Fig. 4.4
Master Group Maintenance

Master Group. Enter a name that uniquely identifies a master group in the current domain.

In the General Settings pane, specify the general settings associated with variant configuration and generation in this group.

Allow Multi-Level product structure. Select this option unless all product structures are single-level.

Enable Routing Calculation. Select this option unless you do not want QAD Configurator to calculate variant routings when generating variant items.

Use Standard Options. Specify whether new feature options can be created in addition to the options inherited from variable standard options when maintaining feature options.

Select this option to allow only variable standard options to be used as feature options. Clear this option to allow new feature options to be defined in addition to the standard options.

UOM. Specify the default unit of measure for variables and features in this group.

In the Default Numeric Format Settings pane, specify the default formats for numeric variables and features in this group. You can change the formats when defining specific numeric variables and features later in Variable Maintenance and Feature Maintenance.

Digits. Specify a value that defaults to the Digits field in Variable Maintenance when you create a new numeric variable.

Rounding Method. Specify the rounding method to be used by numeric variables and features. Standard: Rounds a decimal value to a specified number of fractional digits using the standard midpoint rounding method. A value is rounded up when it is equal or greater than the midpoint value and is rounded down when it is less than the midpoint value. For example, 3.1415 is rounded up to 3.142 when it is rounded to three decimal digits but is rounded down to 3.14 when it is rounded to two decimal digits.

Up: Always round up a decimal value to a specified number of fractional digits. For example, both 3.141 and 3.148 are rounded up to 3.15 when they are rounded to two decimal digits.

Down: Always round down a decimal value to a specified number of fractional digits. For example, both 3.141 and 3.148 are rounded down to 3.14 when they are rounded to two decimal digits.

Decimal. Specify the number of fractional digits for numeric variables and features.

Allow Negative. Specify whether negative values are allowed for numeric variables and features. Select this option to permit variable and feature values to be smaller than zero; otherwise, clear this option.

In the Configurable Item Selection pane, specify the default settings for the variant product rule filter in Variant Product Structure Rule Maintenance. These options are used to filter component items in the product structure when you define variant item product structure rules for a configurable item. See “Maintaining Variant Item Product Structure Rules” on page 105 for details.

Maintaining Configurable Items

Use Configurable Item Maintenance to create, view, edit, or delete configurable items in QAD Configurator. You can also define some default settings that will be used for variant items created from a configurable item. Adding a configurable item in QAD Configurator is a process of selecting a parent item in QAD EA and defining it as a configurable item.

Fig. 4.5
Configurable Item Maintenance

The screenshot shows the 'Configurable Item Maintenance' window. At the top, there's a menu bar with 'Action', 'Print', 'Preview', 'Delete', and 'Group'. Below that, the 'Configurable Item' field contains '100A' and a 'New' button. To the right is a 'Lock Configurable Item' checkbox. The 'Description' field is 'Finished Good A' and the 'SO Type' is 'BOM'. There's an 'Analyzed On' field with 'NA' and an 'Analyze' button. The 'Configuration Creation Rule' section includes 'Variant P/M' (M), 'Configurable P/M' (M), 'Configuration Selection' (Just Created Configuration), 'Auto Select' checkbox, 'Configuration Retention' (Retain All), 'Variant Item-Site Record' (Current Site Only), and 'Site Variable' (site01). The 'Configurator Questionnaire' section has 'Show Existing Configurations' (First) and a checked 'Show All Options Of Feature' checkbox. The 'Cost' section has 'Variant Item Cost Roll-Up' checkbox and 'Cost Set' dropdown. The 'Pricing' section has 'Calculate Configuration Price' checkbox, 'Create a Price List' checked, 'Customer Specific List Price' checked, 'Allow Net Price Change' checkbox, 'Allow Manual Price List Change' checkbox, 'Store All Pricing Information' checkbox, 'List Price Variable' field, and 'Net Price Variable' field. At the bottom are 'Cancel', 'Save', and 'New' buttons.

Configurable Item. Select a configurable item to view, modify, or delete. Click the New button to add a new configurable item.

Note In QAD 2008.1 Enterprise and later, configurable items cannot have item replacement records and cannot be memo items.

Description. The field displays the item description from the QAD EA item details.

Lock Configurable Item. Select this option to lock the configurable item so that it cannot be configured in the questionnaire; clear the check box to unlock it.

SO Type. Designate the configurable item as a product structure, a physical or a phantom kit. The default type is BOM.

Note If the configurable item has been designated as a planning item, you cannot change its SO type to Physical or Phantom.

BOM: Just one sales order or quote line is created for the variant item.

Physical: A physical kit is used in situations where the kit is pre-assembled and can be placed in inventory. If a configurable item is designated a physical kit, the following applies:

- A final assembly item is generated and retained.
- A standard product structure is generated and retained.
- The first line of the quote or sales order will be the top-level kit. This line will be designated as a memo line. The pricing for the entire kit will display on this line.

- Each level-one component of the kit will have its own quote or sales order line. The line-item quantity will be set to the quantity defined in the kit product structure. The price for each component will be \$0.00.
- Pricing for the kit can use all standard pricing methods including QAD Configurator feature/options based pricing.

Phantom: A phantom kit is used in situations where the kit will be assembled and shipped using the QAD EA pick list and will never be placed in inventory. If a configurable item is designated a phantom kit, the following will apply:

- No final assembly item or product structure is retained.
- Each component of the kit will have its own quote or sales order line. The line-item quantity will be set to the quantity defined in the generic product structure or product configuration rule. Pricing for each individual component can be turned on or off in Variant Product Structure Rule Maintenance; for example, a free user manual when a system is purchased.
- Pricing for the kit can use all standard pricing methods including QAD Configurator feature/options based pricing.

Analyzed. This field indicates whether the configurable item has been processed by the QAD Configurator Analyzer. If it has been analyzed, the other two fields show the date and time the configurable item was last analyzed. You can click the Analyze button to force reanalysis of this configurable item.

Variant P/M. Specify the default P/M type of variant items created from the current configurable item.

Configurable P/M. Displays the P/M type of the current configurable item.

Configuration Selection. specify the method to be used to select a configuration in the questionnaire for variant items created from this configurable item. When you have finished answering questions in the questionnaire, QAD Configurator displays a browse window showing all the configurations that have the same answers for the configuration key features. It can also highlight one particular configuration in the browse window. You can then select either the highlighted configuration, or another configuration from the list. The options for the selection method are as follows:

- Just created configuration: QAD Configurator always highlights the configuration you have created, regardless of the other existing configurations.
- Select last matching: QAD Configurator highlights the most recently created matching configuration.
- Select first matching: QAD Configurator highlights the oldest matching configuration.

Auto Select. Specify whether variant item number is selected automatically by QAD Configurator or manually by the user.

Configuration Retention. Specify how QAD Configurator handles generated variant items.

Variant Item-Site Record/Site Variable. Specify for each configurable item, whether to create item-site data along with item master records when the system generates variants from the configurable item, and if so, which sites to use to create item-site data.

Note When the item-site data creation feature is disabled during system installation, these two fields are grayed. For information about switching off the item-site data creation feature, see *Installation Guide: QAD Configurator*.

- **None:** The variants to be generated are non-site-specific and no variant item-site data will be created.
- **Current site only:** The system will generate variant item-site data specific to a particular site.

If you choose this option, you must specify a valid site variable for creating item-site data in the Configurator questionnaire. A valid site variable is a site associated with the configurable item as defined in Item-Site Planning Maintenance (1.4.17) in QAD EA.

When you access the questionnaire from a sales order or sales quote, the site variable defaults from the site in the sales order or quote header. However, if the header site is not valid, the site variable then defaults from the default site of the configurable item;. When you access the stand-alone questionnaire function, the site variable defaults from the default site of the configurable item.

- **All sites:** The system will generate variant item-site data specific to all the sites associated with the configurable item as defined in Item-Site Planning Maintenance.

When you create new variant items at the end of the configuration process, the system creates the following variant item data depending on the Variant Item-Site Record option you choose for the current configurable item.

	None	Current Site Only	All Sites
Item master	Yes	Yes	Yes
Product structure	Yes	Yes	Yes
Routing	Yes	Yes	Yes
Cost data (if cost roll-up is selected)	Yes	Yes	Yes
Item-site planning data		Yes (specific to the specified site)	Yes (specific to all the sites associated with the configurable item)
Item-site inventory data		Yes (specific to the specified site)	Yes (specific to all the sites associated with the configurable item)
Item-site cost data (if cost roll-up is selected)		Yes (specific to the specified site)	Yes (specific to all the sites associated with the configurable item)

If the Variant Item-Site Record option is Current Site Only, when you reload an existing configuration with variant items, the system checks whether a different site variable has been specified than the one previously used to generate the existing variant items. If so, the system creates additional variant item-site data specific to the new site variable.

Note Configurable items on multiple levels of a product structure cannot share the same site variable.

Show Existing Configurations. Specify whether and how to display existing configurations in the Configurator questionnaire:

- **First:** Display existing configurations on launching the questionnaire.
- **Second:** Display the new configuration on launching the questionnaire.

- On request: When launching the questionnaire, display a message asking the user whether to show existing configurations.
- No: Hide the Existing Configurations tab in the questionnaire.

Show All Options of Feature. Specify whether to show all feature options. If this setting is selected, the excluded options, which are not available to select, can be seen as dimmed. If this setting is not selected, you cannot see the excluded options.

Variant Item Cost Roll-Up. Indicate whether the cost roll-up function is to be applied to this item.

Cost Set. Specify the cost set to use in cost roll-up calculations. This field only applies when cost roll-up is in use.

Calculate Configuration Price. Select the check box if you want to use pricing for this configurable item. If you do not select this check box, the Pricing column will appear in the questionnaire, but no pricing information will be shown. The remaining pricing fields on this screen apply only when you select the Use Pricing check box.

Allow Net Price Changes. Select the check box if you want to change the calculated net price for a specific component that is selected in the questionnaire.

Note This setting does not apply for the integration of the Configurator questionnaire with QAD CSS (an add-on product for QAD EA).

Allow manual price list changes. Select the check box if you want to update the manual price list of a selected component while running the questionnaire.

Note This setting is for internal use; it does not work for questionnaire shown in QAD CSS.

Store All Pricing Info. Specify how much pricing information is stored by QAD Configurator. If you select this check box, QAD Configurator stores the pricing information of all the components that can be selected in the questionnaire, according to the possible options for each feature in the model. This may cause performance problems because many records could be created. In such cases, it is recommended that you do not select this check box, in which case only the pricing information of the actual option chosen is stored in QAD Configurator.

Create a Price List. Specify whether you want the system to create price lists for generated variant items. If you select this option, you must specify list price and net price variables to store price information.

Customer Specific List Price. This setting only applies when Create a Price List is selected. By default, this setting is selected when Create a Price List is selected. This setting is to control whether the price list for list price, created by the system, is customer specific or not.

- If this check box is selected, the price list for list price, which is created by the system, is based on the current customer.
- If this check box is not selected, the created price list for list price is general, not customer specific.

Whether the check box is selected or not, the created price list for net price is always customer-specific.

List Price Variable. Specify the variable to store the list price. List price represents the unit price before applicable discounts or markups are applied. This value is used by the system to calculate the net price. The list price is posted to the Sales account during invoice post. If there is a difference between the net price and list price, the difference is posted to the Sales Discount account.

Net Price Variable. Specify the variable to store the net price. The net price represents what the customer pays. It prints on all formal documents and helps calculate taxes, sales margins, and commission amounts. Any difference between the list and net price is posted to the Sales Discount account during invoice post.

The following table lists the effects of different combinations of choices for Auto Select, Configuration Selection, and Configuration Retention.

Table 4.1
Field Combination Effects

Configurati on Selection	Auto Select	Configuration Retention	Effect
Just Created	Yes	Retain all Configurations and Disabled	QAD Configurator always creates a new variant and keeps all configurations.
Just Created	No	Retain all Configurations and Disabled	The Configuration Selection browse is opened and the Just Created Configuration is highlighted. The variant part number selected and accepted in the browse is returned to the SO line. The variant part number is assigned to the new configuration and this new configuration is returned to pcsod_det. If the new configuration is selected and accepted, it creates a new variant from this configuration and this configuration is returned to pcsod_det.
First matching	Yes	No Duplicates	The first matching configuration (if available) is selected. This variant part number is automatically returned to the SO line (bypassing the Configuration Selection browse). The new configuration is deleted and the selected configuration is returned to pcsod_det.

Table 4.1 — *Field Combination Effects* (Page 1 of 4)

Configurati on Selection	Auto Select	Configuration Retention	Effect
First matching	Yes	No Customer Duplicates	<p>The first matching customer-configuration or first matching configuration (if available) is selected.</p> <p>This variant part number will automatically be returned to the SO line (bypassing the Configuration Selection browse).</p> <p>If a customer-configuration match was found, the new configuration is deleted and the existing resid is returned to pcsod_det. If a configuration match were found for a different customer, the matching variant part number is assigned to the new configuration and the new configuration is assigned to pcsod_det.</p>
First matching	Yes	Retain All Configurations	<p>The first matching configuration (if available) is selected.</p> <p>This variant part number will automatically be returned to the SO line (bypassing the Configuration Selection browse).</p> <p>The variant part number is assigned to the new configuration and this new configuration is returned to pcsod_det.</p>
First matching	No	No Duplicates	<p>The Configuration Selection browse is opened and the first matching configuration (if available) is highlighted.</p> <p>The variant part number selected and accepted in the browse is returned to the SO line.</p> <p>The new configuration is deleted and the selected configuration is returned to pcsod_det.</p>
First matching	No	No Customer Duplicates	<p>The Configuration Selection browse is opened and the first matching customer-configuration or, if not available, the first matching configuration (if available) is highlighted.</p> <p>The variant part number selected and accepted in the browse is returned to the SO line.</p> <p>If a customer-configuration match was found, the new configuration is deleted and the existing resid is returned to pcsod_det. If a configuration match were found for a different customer, the matching variant part number is assigned to the new configuration and the new configuration is assigned to pcsod_det.</p>

Table 4.1 — *Field Combination Effects* (Page 2 of 4)

Configurati on Selection	Auto Select	Configuration Retention	Effect
First matching	No	Retain All Configurations	<p>The Configuration Selection browse is opened and the first matching configuration (if available) is highlighted.</p> <p>The variant part number selected and accepted in the browse is returned to the SO line.</p> <p>The variant part number is assigned to the new configuration and this new configuration is returned to pcsod_det.</p> <p>If the new configuration is selected and accepted, it will create a new variant from this configuration and this configuration is returned to pcsod_det.</p>
Last matching	Yes	No Duplicates	<p>The last matching configuration (if available) is selected.</p> <p>This variant part number will automatically be returned to the SO line (bypassing the Configuration Selection browse).</p> <p>The new configuration is deleted and the selected configuration is returned to pcsod_det.</p>
Last matching	Yes	No Customer Duplicates	<p>The last matching customer-configuration or last matching configuration (if available) is selected.</p> <p>This variant part number will automatically be returned to the SO line (bypassing the Configuration Selection browse).</p> <p>If a customer-configuration match was found, the new configuration is deleted and the existing resid is returned to pcsod_det. If a configuration match were found for a different customer, the matching variant part number is assigned to the new configuration and the new configuration is assigned to pcsod_det.</p>
Last matching	Yes	Retain All Configurations	<p>The last matching configuration (if available) is selected.</p> <p>This variant part number will automatically be returned to the SO line (bypassing the Configuration Selection browse).</p> <p>The variant part number is assigned to the new configuration and this new configuration is returned to pcsod_det.</p>

Table 4.1 — *Field Combination Effects* (Page 3 of 4)

Configurati on Selection	Auto Select	Configuration Retention	Effect
Last matching	No	No Duplicates	<p>The Configuration Selection browse is opened and the last matching configuration (if available) is highlighted.</p> <p>The variant part number selected and accepted in the browse is returned to the SO line.</p> <p>The new configuration is deleted and the selected configuration is returned to pcsod_det.</p>
Last matching	No	No Customer Duplicates	<p>The Configuration Selection browse is opened and the last matching customer-configuration or, if not available, the last matching configuration (if available) is highlighted.</p> <p>The variant part number selected and accepted in the browse is returned to the SO line.</p> <p>If a customer-configuration match was found, the new configuration is deleted and the existing resid is returned to pcsod_det. If a Configuration match were found for a different customer, the matching variant part number is assigned to the new configuration and the new configuration is assigned to pcsod_det.</p>
Last matching	No	Retain All Configurations	<p>The Configuration Selection browse is opened and the last matching configuration (if available) is highlighted.</p> <p>The variant part number selected and accepted in the browse is returned to the SO line.</p> <p>The variant part number is assigned to the new configuration and this new configuration is returned to pcsod_det.</p> <p>If the new configuration is selected and accepted, it will create a new variant from this configuration and this configuration is returned to pcsod_det.</p>

Table 4.1 — *Field Combination Effects* (Page 4 of 4)

Copying Configurable Item Data

When you want to set up the sales configuration data for a configurable item, you can either build up the variables, features, and rules individually or copy them from an existing configurable item, and then modify them for the new configurable item.

Fig. 4.6
Configurable Item Data Copy

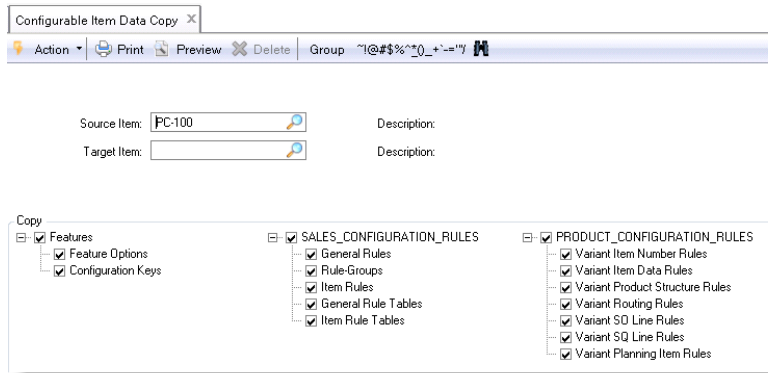

To copy a configurable item data:

- 1 Specify the source and target configurable items for the duplication.
- 2 Specify the sales configuration elements that you want to copy to the new item in the Copy pane.
 - Note** When the target item is a kit, you cannot select variant planning item rule to copy.
- 3 Click OK.

When you confirm the copy, the system displays a message prompting if you want to run the Analyzer for the new configurable item. You cannot use the item in the questionnaire until it has been analyzed. However, you may want to make changes to the sales configuration elements you have copied before running the Analyzer.

If you copy features, feature options, or rules to a new item in which some of these elements already exist, no new copy will be made and no error will be reported. New features, feature options, and rules will be added to those that already exist.

Maintaining External Entities

Use External Entity Maintenance to create, view, edit, or delete external entities for use in QAD Configurator.

An external entity is a reference to a table in a database that lets you establish a link between a question in the questionnaire and customer or item related data in the QAD EA database and use a condition to set the answer to the question. When a variable is linked to an external entity, the questionnaire looks up the assigned value of the feature in the specified field of a particular record in the specified database table. The correct record is determined by the selection rule defined for the external entity.

Note You can update the records in referenced tables by defining external entity rules. For more information, please refer to “Maintaining External Entity Rules” on page 114.

Fig. 4.7
External Entity Maintenance

In the Database and Table fields, use the drop-down lists to select the database and table containing the external entity; then select a field from the table.

To edit a selection rule:

You can either manually type the rule by directly typing the statements in the Rule box or use the Rule Assistant to assist you in the process. See “Using the Rule Assistant” on page 35.

Click Check Syntax to validate the rule syntax. If syntax errors are found, error messages display and the Status becomes Failed.

Click Save to save the rule. On saving the rule, the system performs a syntax check on the rule. If syntax errors are found, error messages display.

Sales Configuration

***Sales Configuration Overview* 59**

Discusses the sales configuration process.

***Maintaining Question Types* 59**

Explains how to use Question Type Maintenance.

***Maintaining Functional Groups* 60**

Explains how to use Functional Group Maintenance.

***Maintaining Variables and Features* 60**

Explains how to use Variable Maintenance, Feature Maintenance, and Feature Sequence Maintenance, as well as how to use system variables.

***Maintaining Sales Configuration Rules* 71**

Explains how to maintain general rules.

***Grouping Sales Configuration Rules* 76**

Explains how to maintain general rules in rule groups, and maintain rule-group-specific rules.

***Applying Sales Configuration Rules* 77**

Explains how to link general rules and rule groups to configurable items and how to maintain item-specific rules.

***About Sales Configuration Rule Table* 79**

Discusses the sales configuration rule tables, table limitations, interpolation and the interpolation process.

***Maintaining General Rules Using General Rule Tables* 83**

Explains how to generate and edit rule tables.

***Maintaining Item Rule Tables* 90**

Explains how to link rule tables to configurable items and how to maintain item-specific rule tables.

***Accelerating Rule Tables* 92**

Discusses how the Rule Table Accelerator works and why you should use it.

***Sales Configuration Rules Report* 93**

Explains how to use Sales Configuration Rule Report.

***Analyzing Sales Configuration Rules* 93**

Explains how to use Configuration Analyzer and how analysis results are handled in the system.

***Maintaining Questions Sequence* 95**

Explains how to use Questionnaire Sequence Maintenance.

***Maintaining Configuration Keys* 96**

Explains how to use Configuration Key Maintenance and address it to pricing.

***Where-Used Report* 97**

Explains how to use Where-Used Report.

Sales Configuration Overview

In the sales configuration process, sales personnel maintain variables and features that define configurable product characteristics, designate how to present features as questions in the guided sales process – questionnaire, as well as set up sales configuration rules to ensure data collected from the questionnaire is valid.

Fig. 5.1
Sales Configuration Process

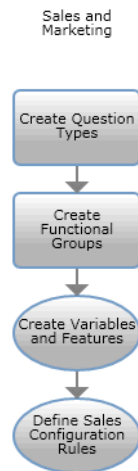
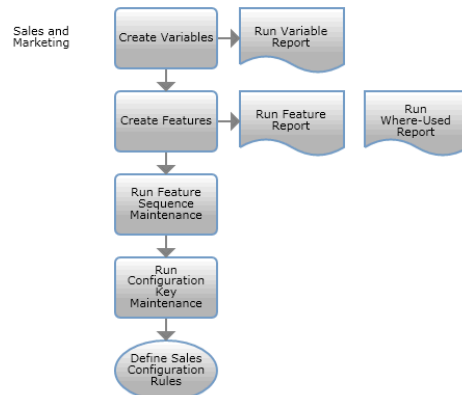

Fig. 5.2
Variable/Feature Maintenance Sub-Process



Maintaining Question Types

You can group or classify questions into different types in order to manage them more efficiently. Use Question Type Maintenance to create, view, edit, or delete question types.

Note Question types are non-domain-specific.

Fig. 5.3
Question Type Maintenance

Level. Specify how this type of questions are displayed and answered in the questionnaire.

Foreground: Questions always appear in the questionnaire and are manually answered by the user.

Background: Questions can be answered automatically by the system according to configuration rules, but can also be answered manually by the user if required. You can suppress Background questions so that they do not display in the questionnaire.

Maintaining Functional Groups

Use Functional Group Maintenance to create, view, edit, or delete functional groups.

Functional groups are used to categorize variants and features by their functions. For example, you can group features of a computer product into hardware, software, and accessories.

Fig. 5.4
Functional Group Maintenance

Maintaining Variables and Features

Maintaining Variables

Use Variable Maintenance to create, view, edit, or delete variables.

Fig. 5.5
Variable Maintenance

Variable . Enter a variable ID that uniquely identifies a variable in the current master group.

Note You must enter a variable ID and press Enter or Tab first before you can edit other fields in the screen.

Note You cannot use spaces in variable IDs. Use hyphens or underline characters instead, such as pane-color or environment_of_use.

Note You cannot use Progress keywords as variable IDs.

Copy From Variable. To create a new variable, you can also copy from existing variables. Enter the variable ID first, click the Copy From Variable button, and select a variable whose details you want to copy.

Data Type. Select a variable data type from the drop-down list. The default data type is numeric. Which data type you choose determines the content under the Data Format tab and whether the Variable Options tab will display in the lower pane of the screen.

Note Once you have selected a data type, you cannot change it even if you have not saved the variable yet.

Extent. Specify the number of times or instances the variable can be used in a questionnaire.

For example, you want collect requirements regarding the colors of body, interior, and seats of a car in the questionnaire, there are two ways you can define variables:

- Create three variables: body-color, interior-color, and seat-color.
- Or, create one variable color with an extent of 3, and then use it three times in questionnaire and different them by assigning an extent number to each instance:

color[1] = body

color[2] = interior

color[3] = seats

However, these relationships are not so obvious when the variable instances display as questions in the questionnaire, and you must use extent numbers correctly when creating rules that involve variables with multiple extents.

Variable Details

Use the settings under Variable Details to specify how questions relating to this variable will be generated. You can further modify these settings at the feature level.

Functional Group. Assign the variable to a functional group. Functional groups are used to categorize variables and features and are maintained in Functional Group Maintenance.

Question Type. Specify the question type for the variable. Question types are defined in Question Type Maintenance.

Short Question. Enter a brief question to display in the questionnaire to prompt for answers relating to this variable.

Long Question. Enter a longer question to display in the questionnaire.

You can customize the questionnaire to display either short or long questions.

UOM. Enter the unit of measure for the variable. This field sets the default for the same field in Variable Options Maintenance.

This field is only enabled when data type is numeric, numeric list, or text

Allow Fill-In. Specify whether to display an additional text field for the question related to this variable in the questionnaire so that the question respondent can type in a free-format answer or select an answer from an associated browse, if any.

This field is only enabled for text, date, and numeric list variables. For temporary questions, this field is always dimmed.

Browse Code. When Allow Fill-In is selected, you can associate the variable with an existing browse so that the question respondent can select a value from the browse instead of manually typing in an answer in the questionnaire. Specify a browse code to associate the browse with the variable. If you assign a browse code to the variable, the answer to the corresponding question must be a value from the browse.

When the Browse Code is specified, users can specify as many as five parameters for the browse in the questionnaire; the parameter can be a variable, a feature, or even a constant.

Browses are created and maintained in Browse Maintenance. For information about creating browses, see QAD Enterprise Applications user guide.

This field is only enabled when variable data type is text and Allow Fill-In is selected.

Note This setting does not apply for the integration of the Configurator questionnaire with QAD CSS (an add-on product for QAD EA). QAD CSS does not support .Net UI browses.

Temporary. Specify how the question will be displayed and answered in the questionnaire:

Question. This is a standard question that will be answered by the user in questionnaire. If you select this option, the question will be automatically answered by the system in the questionnaire. You can customize the questionnaire to display or hide temporary questions.

Temporary questions are used to store information that does not need to be answered or does not necessarily have a question associated with it in the questionnaire.

Example Area is the product of length and width. You can define a temporary variable called area that will be calculated from the answers to the two variables length and width. You can then use the value of the area variable as a factor in other rules.

The Pricing Information pane is available under Variable Details when variable data type is numeric, element, or date (current or fixed).

Pricing Part. Enter an existing item number in QAD EA to associate it with the answer to this question for pricing calculation.

Note There is no validation of the value you enter in this field. You can specify an item for the variable here in QAD Configurator first and then create it in QAD EA.

Qty Based. Select this option to use the answer to this question as the item quantity in pricing calculation.

You can select the Qty Based field only if the type of the variable is numeric or numeric list. If you select this check box, the QAD pricing engine will be run with a quantity equal to the value entered for the feature in the questionnaire. If you do not select this check box, there are two possibilities: either the pricing engine will be run with the value 1 as quantity or the pricing engine will be run with the value of the pricing attribute of the feature. You can set the pricing attribute of a feature using a pricing rule. This quantity is an important input parameter to the QAD pricing engine because prices of components can depend on the number of components that are sold.

UOM. Enter the unit of measure of the item specified in the Pricing Part field. This field will be used by the pricing engine in price calculation.

Variable Data Format

Different variable data types have different data formats.

Note The Data Format pane is disabled for the text and logical data types.

Numeric Data Format

Numeric data format applies to numeric and numeric list data types. The default values for these numeric settings are defined for the group in Master Group Maintenance, but you can change them for individual variables.

Fig. 5.6
Numeric Format

The screenshot shows the 'Numeric Format' configuration pane. It includes the following fields and options:

- Digits:** Input field containing the value 8.
- Decimals:** Input field containing the value 2.
- Rounding Method:** A dropdown menu currently set to 'Standard'.
- Allow Negative Values:** An unchecked checkbox.
- Minimum:** An empty input field.
- Maximum:** An empty input field.
- Multiplier:** Input field containing the value 0.00.
- Default:** Input field containing the value 0.00.

Digits. Specify the maximum number of digits for numeric variables and features. The value defaults from Master Group Maintenance.

Decimals. Specify the number of fractional digits for numeric variables and features.

Rounding Method. Specify the rounding method to be used by numeric variables and features.

Standard: Rounds a decimal value to a specified number of fractional digits using the standard midpoint rounding method. A value is rounded up when it is equal or greater than the midpoint value and is rounded down when it is less than the midpoint value. For example, 3.1415 is rounded up to 3.142 when it is rounded to three decimal digits but is rounded down to 3.14 when it is rounded to two decimal digits.

Up: Always round up a decimal value to a specified number of fractional digits. For example, both 3.141 and 3.148 are rounded up to 3.15 when they are rounded to two decimal digits.

Down: Always round down a decimal value to a specified number of fractional digits. For example, both 3.141 and 3.148 are rounded down to 3.14 when they are rounded to two decimal digits.

Allow Negative Values. Specify whether negative values are allowed for numeric variables and features. Select this option to permit variable and feature values to be smaller than zero; otherwise, clear this option.

Minimum. Specify the minimum value allowed. Leaving it blank means there is no lower boundary.

Maximum. Specify the maximum value allowed. Leaving it blank means there is no upper boundary.

Multiplier. Specify a fixed incremental value.

Default. Specify the default value for the variable.

Date Format

The date format settings display when the variable data type is date.

Fig. 5.7
Date Format

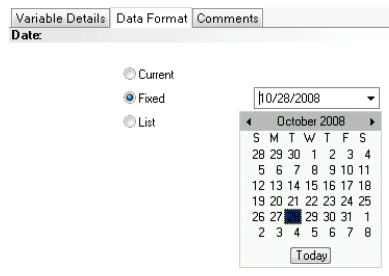

Current. The value of the variable will default to the date on which the questionnaire is answered.

Fixed. The variable value is a fixed date. Specify a default value using the date selection calendar to the right.

List. When you select this option, the Variable Option tab is enabled to allow you to specify date options for the variable.

Element Format

Element format settings apply to element type variables. Use the settings to link the variable to a database entity field.

Fig. 5.8
Element Data Format

Element Type. Specify whether you want to associate the variable with an internal or external entity field.

Internal: The Entity option list displays all the tables in the QAD Configurator database.

External: The Entity option list displays all the external entities defined in External Entity Maintenance.

Entity. Select an entity to associate the variable with.

Field. Select a field to link the variable to.

Extent. This value is 1 when the selected field is of the array data type in the database. When this is the case, specify the index number of the field in the array you want to link the variable to. Do not modify the Extent field when its value defaults to 0.

Note The lower boundary of the array index range is 1.

Variable Options

The Variable Options tab displays when the variable data type is text, numeric list, logical, or date with the List date format. Use this tab to maintain options, or selectable values of the variable.

Fig. 5.9
Variable Options List

Se	Default	Option	Description	Short Question	Long Question	Pricing Part	Qty Based	UOM
1	<input checked="" type="checkbox"/>	alkaline batt	alkaline batt	alkaline batt			<input type="checkbox"/>	
2	<input type="checkbox"/>	atomic batt.	atomic batt.				<input type="checkbox"/>	
3	<input type="checkbox"/>	thermonucle	thermonuclear ba				<input type="checkbox"/>	
4	<input type="checkbox"/>	n.a.	n.a.				<input type="checkbox"/>	

The toolbar at the top of the variable options gives you access to all the variable option maintenance functions including creating, modifying, deleting options, as well as setting the default option and arranging the order of options.

Maintaining Variable Options

To create a new variable option, click the Create button on the toolbar. To modify an existing variable option, select the option in the list and click the Modify button on the toolbar or double-click the option in the list.

Enter variable option information in the Variable Option Maintenance dialogue box.

Fig. 5.10
Variable Options Maintenance

Option. Enter a selectable value as a variable option. What you can enter in this field is determined by the variable data type and data format. For example, if the variable data type is numeric list and the numeric data format is defined as a positive 1-digit number with no decimals, you can only enter a number between 0 and 9.

Short Answer. Optionally enter a short answer that represents the option in the questionnaire.

Long Answer. Optionally enter a long answer that represents the option in the questionnaire.

Note You can choose whether to display option value, short answer, or long answer when customizing the questionnaire.

Pricing Part. Enter an existing item number in QAD EA to associate it with the answer to this question for pricing calculation.

Note There is no validation of the value you enter in this field. You can specify an item for the variable here in QAD Configurator first and then create it in QAD EA.

Qty Based. Select this option to use the answer to this question as the item quantity in pricing calculation.

UOM. Enter the unit of measure of the item specified in the Pricing Part field. This field will be used by the pricing engine in price calculation.

Setting the Default Option

The first option you create automatically becomes the default option. As you create more options, you can change the default option by selecting another option and click the Set Default button on the toolbar. Text or numeric list type Variable/Feature can be defined with no default value.

Changing the Order of Variable Options

To change the order in which to display variable options, use the Move to Top, Move Up, Move Down, and Move to Bottom buttons on the toolbar to arrange the position of the options in the list. To move multiple options around, press and hold down Ctrl to select nonconsecutive options or press and hold down Shift to select a range of consecutive options and use the Move buttons on the toolbar.

However, the order defined here may not be the final option order that will be displayed under the question associated with this variable in the questionnaire. Further changes can be made in Feature Maintenance where you can include or exclude some of the options, add new feature options, and rearrange their order.

Maintaining Features

Use Feature Maintenance to create, view, edit, or delete features.

Fig. 5.11
Feature Maintenance

Select a group and a configurable item using the binocular buttons on the toolbar. If you select a group that contains no configurable item in it, the system will display an error message and the Feature Maintenance screen will be disabled.

To create a new feature, either click the New button at the bottom or click the Copy From Variable button next to the Feature field; then select a variable to associate it with the current configurable item as a feature.

To edit an existing feature, enter the feature ID in the Feature field.

You cannot delete feature when it is used in any variant planning item rule.

Feature Details

All the feature details inherit from the selected variable details. You can change this information for the feature. See “Variable Details” on page 62.

Feature Options

Feature options inherit from the options of the selected variable. If you set the Use Standard Options option to Yes for the current group in Master Group Maintenance, you can only use variable standard options to be used as feature options. If you set this value to no, you can modify the variable standard options for the feature or add new options.

Fig. 5.12
Feature Options List

Se	Default	Option	Description	Short Question	Long Question	Pricing Part	Qty Based	UOM
10	<input type="checkbox"/>	Red	Red	Red	The colour red	ATP01	<input type="checkbox"/>	
20	<input type="checkbox"/>	Blue	Blue	Blue	The colour blue	ATP01	<input type="checkbox"/>	
30	<input type="checkbox"/>	Green	Green	Green	The colour green	ATP01	<input type="checkbox"/>	
40	<input type="checkbox"/>	Black	Black	Black	The colour black	ATP01	<input type="checkbox"/>	

If you click the Standard Options button on the toolbar, only the variable options will be available for this feature. You cannot exclude any of the variable options or add new options for this feature. Click this button again if you want to modify the standard variable options for the feature.

To include a variable option as a feature option:

Select its check box on the left. Clear the check box to exclude it from the feature options.

Modify feature options in the same way as you modify variable options. See “Variable Options” on page 65.

Maintaining Feature Sequence

Use Feature Sequence Maintenance to set the sequence in which feature-associated questions will be presented in the questionnaire. The extent to which you can control the sequence is determined by the dependencies among feature options. When the Analyzer processes the sales configuration for a configurable item, it imposes a sequence for the questions so that questions that depend on answers to other feature questions are asked after the questions on which they depend. However,

within the constraints of the logical structure of the questions, you can arrange the sequence of feature questions in any way you want. If you specify a sequence that ignores the logical structure, the Analyzer will rearrange the sequence so that the logical requirements are satisfied.

Fig. 5.13
Feature Sequence Maintenance

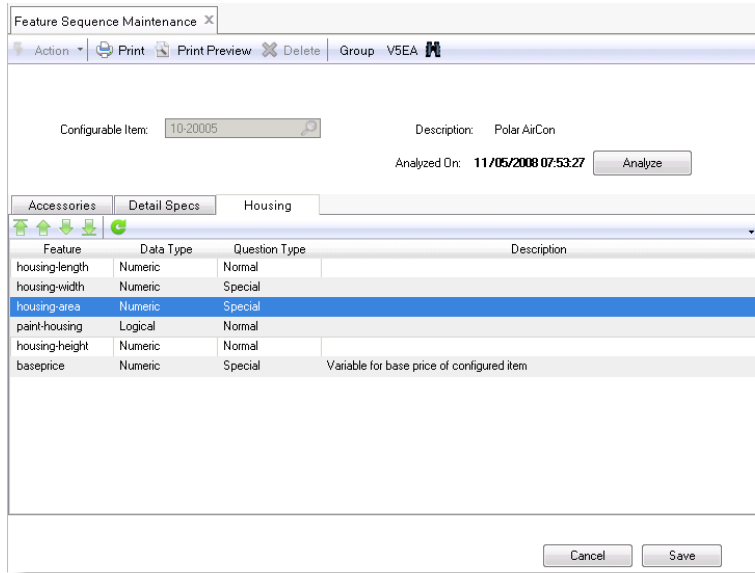

To change the order of functional groups:

Drag and drop the functional group tab your desired position.

To change the order of features:

Use the Move to Top, Move Up, Move Down, Move to Bottom, and Reverse Order buttons on the toolbar to arrange the position of the features in the list. To move multiple features around, press and hold down Ctrl to select nonconsecutive features or press and hold down Shift to select a range of consecutive features and use the buttons on the toolbar.

When you have finished rearranging the feature list sequence, click OK to save the new sequence. The system displays a message telling you that you need to run the Analyzer to activate the question sequence in the questionnaire.

Using System Variables

You can use the following exposed system variables when defining sales and product configuration rules.

Variable	Description	Comment
sysDomainID	Current domain ID	Used in both sales and product configuration rules.
sysGroupID	Current master group ID in Configurator	
sysConfigurableItemID	Current configurable item ID	
sysUserID	Current QAD EA log-in user ID	
sysUserLanguage	Current QAD EA user language code	
sysConfigurationID	Configuration ID	<ul style="list-style-type: none"> When used in sales configuration rules, the variable contains the reloaded configuration ID for reloaded configurations and is blank for new configurations. When used in product configuration rules, the variable contains the current configuration ID.
sysVariantItemID	Variant item number	<ul style="list-style-type: none"> When used in sales configuration rules, the variable contains the variant item number for reloaded configurations and is blank for new configurations. When used in External Entity Rules, the variable contains the variant item number regardless of whether the configurations are new or reloaded.
sysConfigurationDesc	Current configuration description	<ul style="list-style-type: none"> When used in sales configuration rules, the variable can be assigned for the configuration description. Write only. When used in product configuration rules, the variable contains the current configuration description.
sysConfigurationCmmt	Current configuration comment	<ul style="list-style-type: none"> When used in sales configuration rules, the variable can be assigned for the configuration comment. Write only. When used in product configuration rules, the variable contains the current configuration comment.

Variable	Description	Comment
sysExtLaunch	Who to launch Configuration Questionnaire	<ul style="list-style-type: none"> If the value is EA, Configuration Questionnaire is launched from QAD Enterprise Applications. If the value is a CSS, Configuration Questionnaire is launched from QAD CSS.
sysQuestLaunch	Where to launch Configuration Questionnaire	<ul style="list-style-type: none"> If the value is SQ, Configuration Questionnaire is launched from Sales Quote. If the value is SO, Configuration Questionnaire is launched from Sales Order. If the value is CSS, Configuration Questionnaire is launched from QAD CSS. If the value is SA, the Configuration Questionnaire is a stand-alone questionnaire function.

Maintaining Sales Configuration Rules

Maintaining General Rules

Use General Rule Maintenance to create, view, edit, or delete general sales configuration rules.

Fig. 5.14
General Rule Maintenance

When creating a new rule, you can either build it from scratch, or copy from an existing one and modify it. To copy from an existing rule, click the Copy From Rule button next to the Rule ID field and select the rule you want to copy from in the pop-up browse window to bring it in. You can then proceed to make modifications to the duplicated rule.

Composing Rules

To compose conditional and assignment rules:

- 1 In the Rule Editor pane, select a conditional rule type. If you select Conditional, If, Then, and Else statements display; If you select Assignment, only an Assign statement displays.
- 2 Edit rule statements. Each statement, whether it be an If, Then, Else, or Assign statement, consists of a variable, an attribute, an operator, and a value. Specify these components in the statement. For the IF conditional statements, you can convert them to free format and edit the conditions manually. A conditional rule must have at least an If Statement and an Else statement.
- 3 To add a new statement after an existing one, click the + sign next to the statement; To delete an existing statement, click the X sign next to it.
- 4 To change the order of the statements, click the Move Up or Move Down signs next to the statement to move it up or down.
- 5 Click the Update button to display the rule you are composing in the Preview pane.

Note Once you click the Update button, you can not modify existing statements in the current rule. However, you can still delete existing statements and add new ones.
- 6 Click the Check Syntax button to check whether the rule syntax is correct. If the rule is valid, you can see the status Passed under the button; otherwise, a Rule Check Configuration window will pop up displaying detailed error messages.

Note The syntax check function only checks the rule in the Preview pane. Any changes you make in the Rule Editor pane are not validated.
- 7 Click Save to save the rule.

Composing Statements in Basic Format

To compose a conditional statement:

- 1 Select a variable from the Variable drop-down list. Only variables pertaining to the current master group are available for selection.
- 2 Select a variable attribute from the Attribute drop-down list. Variable attributes differ for different types of variables in different statements.

Statement	Variable Data Type	Available Attributes
IF	numeric, numeric list	Value, Min, Max, Default, Multiplier
IF	text, date, logical, element	Value, Default
THEN, ELSE, ASSIGN	numeric, numeric list	Value, Min, Max, Default, Multiplier, Show
THEN, ELSE, ASSIGN	text, date, logical, element	Value, Default, Pricing Qty, Show

- 3 Select an operator from the Operator drop-down list. Available operators differ for numeric and non-numeric variables in different statements.

Statement	Variable Data Type	Available Operators
IF	numeric, numeric list	=, <, <=, >, >=
IF	text, date, logical, element	=, <
THEN, ELSE, ASSIGN	numeric, numeric list	=, <
THEN, ELSE, ASSIGN	text, date, logical, element	=, <

- 4 Click the icon next to the Values/Options field. A Values/Options window displays.

Fig. 5.15
Values/Options Window (Basic Rule Format)

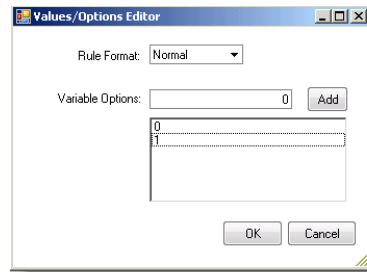

- 5 If you are composing a simple conditional statement that does not involve additional expressions or calculations (for example, color = red), use the Basic rule format. Enter a value or select an option or multiple options in the Values/Options window, which differs for different variable types in basic mode.
- When variable data type is numeric, specify a valid numeric value.
 - When variable data type is text, numeric list, date list, or logical, select an option or multiple options in the list box. Multiple options represent the OR relationship among selected values.
 - For text, numeric list and date list type variables, when Allow Fill-in is selected, you can enter a value and use the Add button to add new options to the option list; then select the options you want.
 - For element, current date, and specified date type variables, you can only specify value using the Advanced rule format.
- 6 If you are composing a more complex conditional statement that involves expressions or calculations (for example, If Length > Width * 2), select the Advanced rule format.

Fig. 5.16
Values/Options Window (Advanced Rule Format)

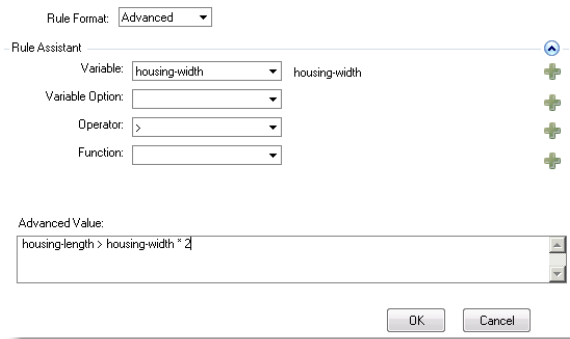

Enter an expression in the advanced format value input box either manually or with the help of the drop-down lists above the input box. You can include any valid combination of available variables, variable options, operators, and functions in the expression. Here is an example of a valid advanced-format expression:

```
round((Width * Length)/12)
```

- 7 Click OK to close the window and return your specified values to the Value field in the conditional statement. You have completed composing the conditional statement.

Composing IF Statements in Free Format

If you are composing complex conditional statements that involve expressions or calculations, you can use the free format. To convert all IF statements to free format and manually edit the conditions, select the Free Format check box next to the first IF statement. All existing conditions you have already composed will be converted to free format. You can also go back from free format to basic format, but all changes in the IF statement will be lost.

Fig. 5.17
Free Format



Free-format expressions take the form of a Boolean expression that will evaluate to true or false. You can use all the basic Boolean operators, brackets, ANDs, and ORs, as well as variable names and option names. Option names for text variables must be enclosed in double quotes, but this does not apply to date list variable options or numeric list variable options.

The free-format mode is applicable only to the IF statement of the rule. A rule can contain only one free-format block, which must define the whole of the IF statement; you cannot combine a free-format IF line with further AND lines for the IF statement in basic or advanced format.

The process of composing a free-format expression consists of entering the details of the expression into the expression editor window. The expression can contain any combination of values, variable options, and Boolean operators with correct Progress syntax. The word IF will be inserted automatically (as for basic and advanced expressions), so you do not need to type this word as part of the expression.

Composing Pricing Rules

You can compose pricing rules using the Pricing Qty attribute of text, date, logical, and element type variables in THEN, ELSE, and ASSIGN statements. Pricing rules are used to set the quantity to be used by the QAD pricing engine for non-numeric features.

Example

```
IF:
    salesprice <> 0.00
THEN:
    pump:pricing_qty = pricing
ELSE:
    pump:pricing_qty = 0
```

The variable pricing is a numeric feature, which gives the quantity of variant items to be configured. This quantity is important because prices for components can differ depending on the number sold. The pricing variable will be filled by answering one of the first questions in the questionnaire. This is because the pricing variable will be one of the subset of independent questions.

The previous rule states that if a number of configurable items is to be configured and the user is selecting a feature option for the feature pump, the QAD pricing engine will calculate prices based on the value of pricing entered in the questionnaire. Pricing rules differ from ordinary rules in that the right side of the equation contains a feature instead of an option. In this example, the value of the feature pricing will be used as the pricing quantity for the pump.

Using the value of feature pricing in the right side of the THEN part of the rule is only possible in advanced mode.

Defining Warning Messages

When constructing sales configuration rules, you can define warning messages to display when a particular rule condition is met during the questionnaire entry process.

To define a warning message:

- 1 Define a logical type variable.
- 2 Create a sales configuration rule and assign the following function to the variable:

```
showMessageBox(title, message)
```

Where *title* is the title of the warning message box and *message* is the warning message you want to display.

- 3 Attach the rule to an item. When the system processes the rule in the questionnaire, the warning message will appear.

Using Custom Functions in Sales Configuration Rules

The system lets you easily define and maintain custom functions in the `pcfunc.i` file and use them in sales configuration rule definitions. Custom functions are called and executed when the system processes general rules and item rules containing them.

Note Custom functions cannot be called from rule tables.

To use a custom function:

- 1 Edit the `pcffunc.i` file to define your custom function using Progress. Here is a sample function that converts time from minutes to seconds:

```
function CovertTime returns integer (input Hours as integer):
return Hours*60
end function.
```

- 2 Define a rule in General/Item Rule Maintenance in the advanced mode and assign the custom function to a variable/feature; for example:

```
If TimeUnit = "Minutes" Then Duration = CovertTime (Hours)
```

Where `TimeUnit`, `Duration`, and `Hours` are all defined variables or features.

- 3 Use Check Syntax to validate both the rule and the custom function.
- 4 When you launch the questionnaire for the configurable item, if you set `TimeUnit` to `Minutes` and `Hours` to `2`, `Duration` will be `120`.
- 5 Whenever there are any changes to the custom function in `pcffunc.i`, you need to analyze the configurable item using Configuration Analyzer to make the changes effective.

Grouping Sales Configuration Rules

Use Rule Group Maintenance to create sales configuration rule groups, link general rules to rule groups, and create rule-group-specific rules.

Fig. 5.18
Rule Group Maintenance

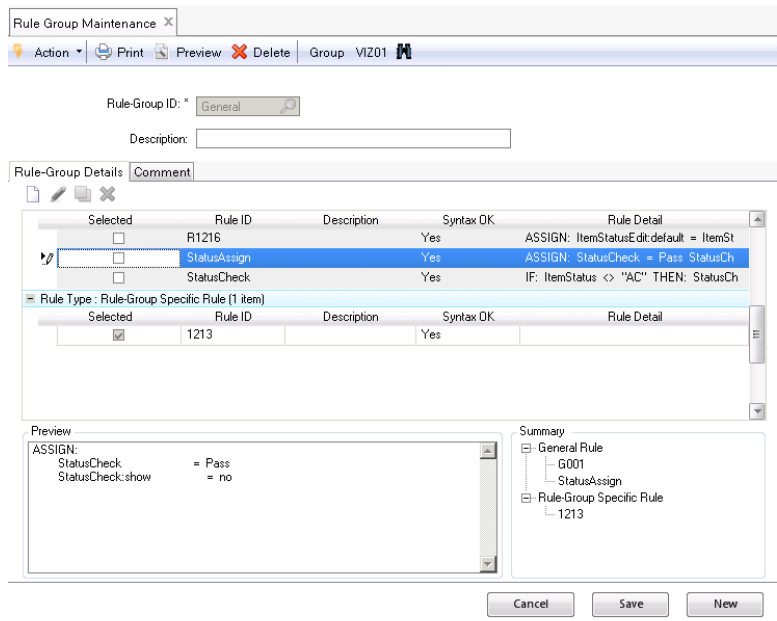

Maintaining General Rules in Rule Groups

To maintain general rules in a rule group:

- 1 Enter a rule group ID in the Rule Group ID field.
- 2 All general rules in the current master group are displayed in the general rule list. Click a rule record to view its full statements in the Preview pane.
- 3 Select the check box next to a rule ID to link it to the current rule group. Clear the check box next to a rule ID to remove the rule from the current rule group. You can see selected rules are grouped under the General Rule node in the Summary pane.
- 4 Click Save.

Maintaining Rule-Group-Specific Rules

To create a rule-group-specific rule:

- 1 Enter a rule group ID in the Rule Group ID field.
- 2 In the Rule Group Details pane, click the New button on the toolbar.
- 3 A General Rule Maintenance window displays. Create a new rule or load an existing rule; then click OK. See “Maintaining General Rules” on page 71.
- 4 The rule is added to the current rule group as a rule-group-specific rule. You can see the rule display in the rule-group-specific rule list as well as under the Rule-Group-Specific Rules Node in the Summary pane.
- 5 Click Save.

To remove a rule-group-specific rule from the current group:

Select the rule in the rule-group-specific rule list and click the Delete button on the toolbar in the Rule Group Details pane.

Applying Sales Configuration Rules

Use Item Rule Maintenance to link general rules and rule groups to items and create item-specific rules.

Fig. 5.19
Item Rule Maintenance

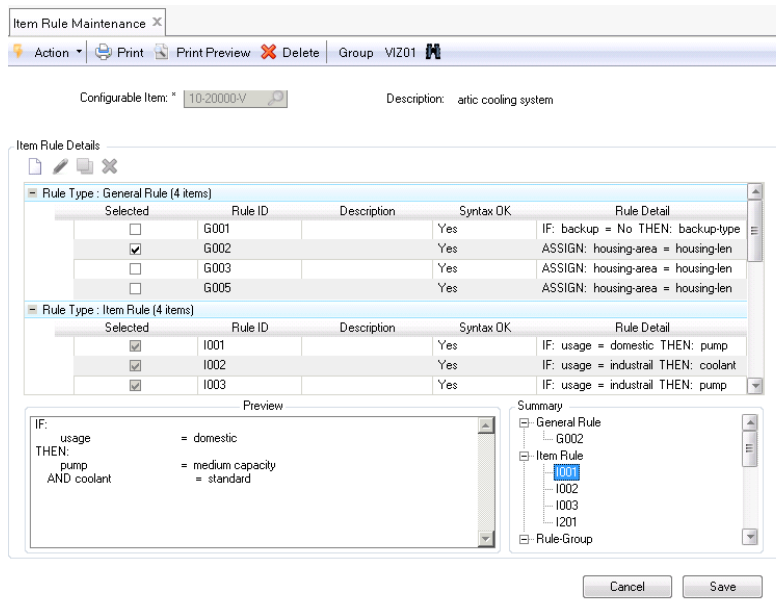

Applying General Rules and Rule Groups to Configurable Items

To apply general rules and rule groups to a configurable item:

- 1 Enter an existing configurable item ID in the Configurable Item field.
- 2 All general rules and rule groups in the current master group are listed in the Item Rule Details pane. Click a rule record to view its full statements in the Preview pane.
- 3 Select the check box next to a rule ID or rule group ID to link it to the current configurable item. Clear the check box next to a rule ID or rule group ID to remove the link between it and the current configurable item. You can see selected rules and rule groups grouped under the General Rule node and the Rule Group node respectively in the Summary pane.
- 4 Click Save.

Maintaining Item-Specific Rules

To create an item-specific rule:

- 1 Enter an existing configurable item ID in the Configurable Item field.
- 2 In the Item Rule Details pane, click the New button on the toolbar.
- 3 A General Rule Maintenance window displays. Create a new rule or load an existing rule; then click OK. See “Maintaining General Rules” on page 71.
- 4 The rule is applied to the current configurable item as an item-specific rule. You can see the rule display in the item-specific rule list as well as under the Item-Specific Rules Node in the Summary pane.
- 5 Click Save.

To remove an Item-specific rule:

Select the rule in the item-specific rule list and click the Delete button on the toolbar in the Rule Group Details pane.

About Sales Configuration Rule Table

Rule tables are used as an easy way to enter one or more straightforward rules. Each rule in a rule table specifies an IF-THEN relationship between variables. You cannot enter rules containing ELSE clauses in a rule table.

A rule table consists of rows and columns. The intersection of a row and a column is called a cell. Row numbers display on the left.

Fig. 5.20
Rule Table

	IF region:Value	IF usage:Value	IF power-converter:Value	THEN pump:Value
1	Western Europe	industrial	standard	medium capacity
2	UK	domestic	smart	high capacity
3	Western Europe	domestic	standard	medium capacity
4	UK	industrial	smart	high capacity
5	USA	industrial	smart	high capacity
6	UK	domestic	standard	low capacity

The variables that are involved in the relationships in the table are shown above the columns. Because a rule generally consists of a number of clauses, the type of clause to which the variable belongs is shown as well. Each row of the table corresponds to a single rule. The cells on a particular row specify the values of the variables that make up the rule.

Suppose you have the following two rules.

```
Rule A:
if coolant = standard
  and usage = industrial
then pump = high capacity
  and power-converter = standard
```

```
Rule B:
if coolant = standard
  and usage = domestic
then pump = medium capacity
  and power-converter = standard
```

The part of the rule table containing these rules would look like this:

	coolant IF	usage IF	pump THEN	power-converter THEN
1	standard	industrial	high capacity	standard
2	standard	domestic	medium capacity	standard

Rule A corresponds to row 1 in the rule table, and rule B to row 2.

A rule table can contain one or more conditions (IF variables) and one or more results (THEN variables); the only restriction is that the total number of variables cannot exceed 20. The various clauses that are specified in a table are linked in an AND relationship, as you can see in the previous example. A variable can appear both in the IF clause and in the THEN clause of a single rule table.

Apart from its actual value, a variable can also have an extent, a minimum value, a maximum value, and a default value. Because of this, you must specify not only the variable-ID and the extent of the variable you want to use in a certain clause of a rule, but also the type of value you are testing for (condition) or manipulating (result). The various types of value are called attributes of the variable. Attributes are displayed after variable IDs in the rule table header. A particular variable, is therefore, characterized by the combination of its ID, its extent, and its attribute. It is in fact this combination that can be used only once in a clause; the same variable with another attribute can be used in the same clause without any problem.

Example

	coolant IF (value)	housing-height IF (value)	housing-height THEN (max)	housing-width THEN (min)
1	standard	200	400	100
2	standard	300	400	200

Rules in a table can only be built from the variables that appear in the table. However, a rule in a table need not use every variable that is available in the table. This means that a column relating to a variable can have empty cells for one or more rules (rows) in the table.

Note The rule table functions only check the syntax of the values in the cells. Thus, it is possible to enter values that are not in the list of options, and values that are outside the range between the minimum value and the maximum value of a variable. In addition, in the case of item-specific rule tables, it is possible to use variables that are not defined as features for the item. By allowing this kind of entry, it becomes possible to define rule tables for future models and there is no need to postpone the definition process for rule tables until changes in current models have been made.

You can move through the cells of a table in the following way. To move one cell to the right, press the Tab key. To move one cell to the left, press the Tab key while holding down the Shift key. To move one cell up or down, use the up arrow and down arrow cursor keys on the keyboard. Continuing down through a column reveals the rows beyond the originally displayed 12.

The two Rule Table Maintenance functions, General Rule Table Maintenance and Item Rule Table Maintenance, are used in the same way as the basic Rule Maintenance functions.

- You can create a general rule table and link it to one or more items afterward without modifying it.
- You can link a general rule table to an item and modify it to make it specific for that item.
- You can create an item-specific rule table without using a general rule table as a basis.

Rule Table Shortcut Keys

You can use shortcut keys to navigate around in a rule table.

Press Ctrl+F to perform the search function within a rule table.

Press Ctrl+G to go to a specified row and column in a rule table.

Rule Table Limitations

The number of rows in a rule table is currently limited to 9999, because this is the maximum number that can be displayed in the Rule Table Maintenance programs. The number of columns (variables) in a rule table is currently limited to 20. Any mix of condition and result variables, that is, IF and THEN columns, is valid as long as you use at least one condition and one result variable.

Cells have the following limitations:

- Progress statements and operators are not allowed.
- An empty range, specified by only a colon (:) is not allowed.
- Ranges and exclusions are not allowed for logical variables.
- Empty dates cannot be handled by the rule tables. Even when using an empty cell, the empty date will not fit the range.
- For a result variable, lists and exclusions are allowed only if the variable is of the type text, numeric, or date list and only if the attribute of the variable is value.

Interpolation

Interpolation is a method by which the system can determine values for result variables that lie between the specific values that you specify in the rule table.

This method only works for rule tables with two numerical conditions (IF clauses) and one numerical result (THEN clause) that have the interpolation switch turned on. Interpolation will only work properly if real numerical values are entered for the conditions and the result. It cannot handle complex formats such as ranges, lists, and exclusions. If both conditions exist in the rule table, interpolation returns the specified result, but if one or both of the conditions cannot be found, simple linear interpolation is used to calculate the result.

For such numerical value rules, the rule table will only define the measure points. The following table shows Production-densities (result) for a given Density (condition 1) and Width (condition 2).

Note This is a table of values, not an example of a rule table.

Table 5.1
Production Density

Density	Width		
	1000	1500	2000
0.8	25	30	40
1.0	32	35	40
2.0	36	42	48

Example If the Density is 0.8 and the Width is 1500, the production density would be 30. However, if the Density was 0.9 and the Width was 1250, there is no specified value in the rule table. Without interpolation, the rule could not provide the required result.

The next table is similar to the previous one, but expanded with interpolated values for production density.

- **Bold** values represent the measure points from the previous table.

- *Italic* values represent condition-values and calculated result-values that do not exist in the rule table.

Table 5.2
Production Density

Density	Width				
	1000	1250	1500	1600	2000
0.8	25	27.5 (a)	30	32	40
0.9	28.5 (b)	30.5 (d)	32.5 (c)	34	40
1.0	32	33.5 (e)	35	36	40
1.2	34	36.25	38.5	39.6	44
2.0	36	39	42 (f)	43.2	48

The letters (a) to (f) identify particular cases that are explained later.

Interpolation Process

The system first determines the closest range (from/to) for both Density and Width. The nearest values are determined by searching in the rule table. For sample values, this means that for cases (a), (b), (c), (d), (e) and (f) the ranges are as follows:

Case	Density			Width		
	Value	From	To	Value	From	To
(a)	0.8	0.8	0.8	1250	1000	1500
(b)	0.9	0.8	1.0	1000	1000	1000
(c)	0.9	0.8	1.0	1500	1500	1500
(d)	0.9	0.8	1.0	1250	1000	1500
(e)	1.0	1.0	1.0	1250	1000	1500
(f)	2.0	2.0	2.0	1500	1500	1500

If the given Density equals the from value of Density and the given Width equals the from value of Width (case f), the result can be taken from the rule table without any calculation. The same is true if the given values equal the to values.

If only the given Density equals the from value or to value of Density (cases a and e), the system uses interpolation rules to calculate the Width.

If only the given Width equals the from value or to value of Width (cases b and c), the system uses interpolation rules to calculate the Density.

If the given Density is unequal to the from or to value of Density and the given Width is unequal to the from or to value of Width (case d), it is necessary for the system to calculate two extra points based on either the given Density or the given Width, representing the closest range for either Density or Width. Interpolation rules then provide the calculated result.

If the given value for Density or Width is outside the scope of the rule table, it is not possible to calculate a result because the system only handles interpolation, and not extrapolation.

Maintaining General Rules Using General Rule Tables

Use General Rule Table Maintenance to create, view, edit, or delete Rule Tables. Rule tables provide an easy way to maintain simple rules.

Fig. 5.21
General Rule Table Maintenance

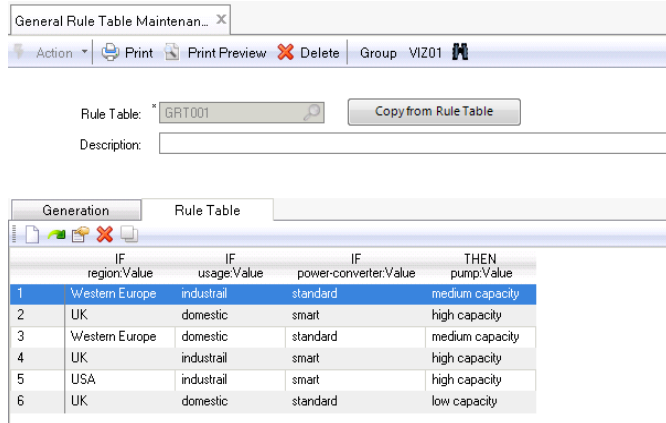

Generating Rule Tables

To generate a rule table, you can copy an existing rule table or create a new rule table from scratch.

To generate a rule table by copying existing rule tables, just click the Copy from Rule Table button, and select a rule table whose rules you want to copy. After the new rule table is generated, you can edit the table to get the rules that you need.

To create a new rule table from scratch, follow the generation wizard:

- 1 Select variables and attributes for the IF conditional statements.

Fig. 5.22
Rule Table Generation - Step 1

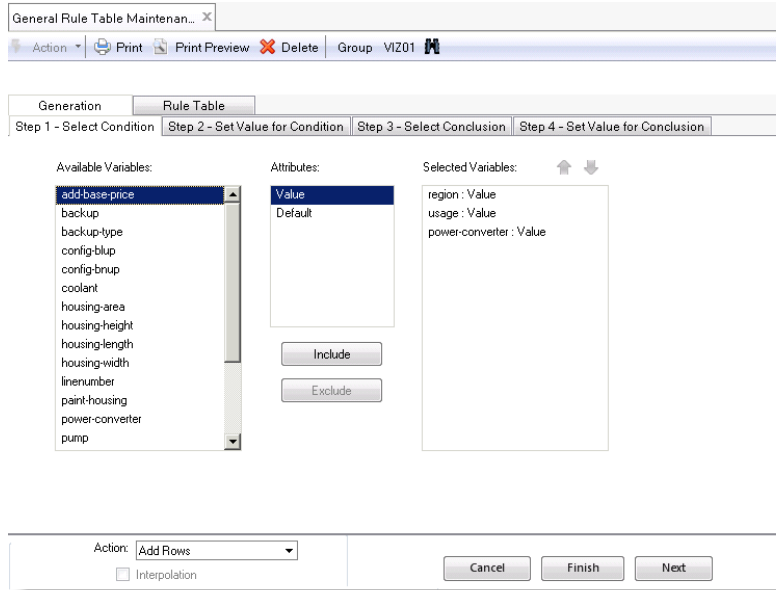

To select a variable into the rule table, click the variable in the Available Variables list box; then double-click the variable's attribute you want in the Attributes list box to move the variable:attribute combination into the Selected Variables list box.

To remove a selected variable from the rule table, double-click it in the Selected Variables list box.

You can also select multiple variables and click the Select or Deselect buttons to add them into or remove them from the Selected Variables list. However, when you select multiple variables in the Available Variables list box, only common attributes shared by all the selected variables are available for selection in the Attributes list box.

To change the order of variables in the Selected Variables list box, use the Up and Down arrows above the list box.

When you have selected all the variables you want, click Next.

- 2 Set values for the variables for the IF conditional statements.

Fig. 5.23
Rule Table Generation - Step 2

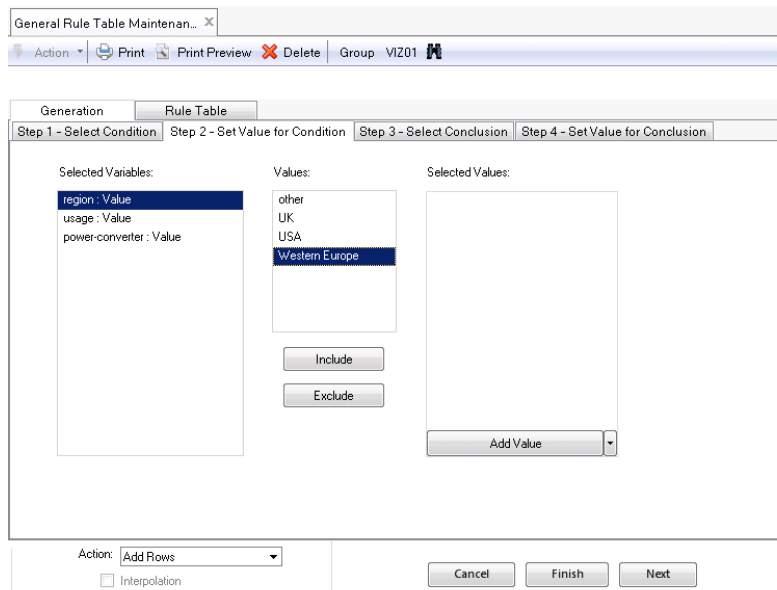

To set the value for a variable as a condition, click the variable in the Selected Variables list box and then choose the following actions:

- If the variable has options, they display in the Values list box. To select an option as the value for the variable, double-click the option.
- To specify a new value for the variable, click the Add Value button and enter a valid value in the Assigned Values list box.
- To specify an empty value for the variable, click the Down arrow next to the Add Value button and select Add Empty Value.

The values you specify display under the variable node in the Assigned value list box.

After you finish assigning values, click Next.

- 3 Select variables for the THEN statements.

Fig. 5.24
Rule Table Generation - Step 3

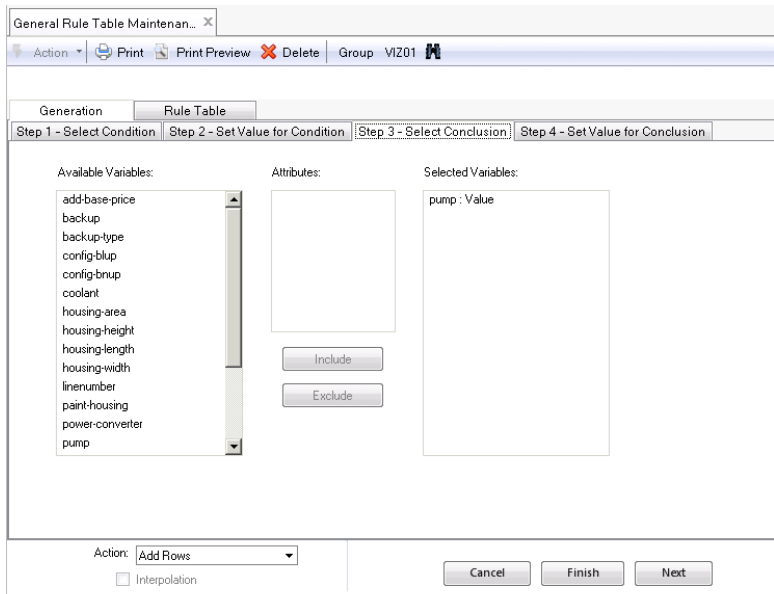

To select a variable into the rule table, click the variable in the Available Variables list box; then double-click the variable's attribute you want in the Attributes list box to move the variable:attribute combination into the Selected Variables list box.

To remove a selected variable from the rule table, double-click it in the Selected Variables list box.

You can also select multiple variables and click the Select or Deselect buttons to add them into or remove them from the Selected Variables list. However, when you select multiple variables in the Available Variables list box, only common attributes shared by all the selected variables are available for selection in the Attributes list box.

When you have selected all the variables you want, click Next.

- 4 Set values for the variables for the THEN statements.

Fig. 5.25
Rule Table Generation - Step 4

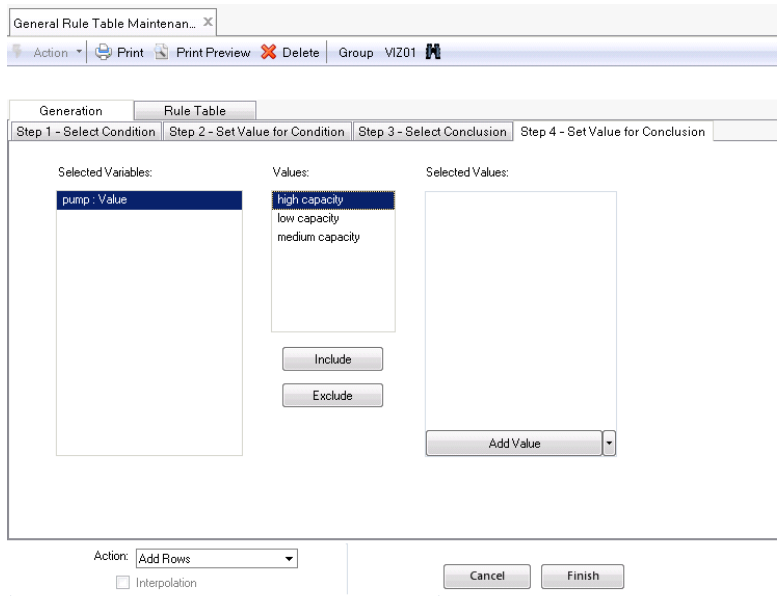

To assign a value to a variable in a THEN statement, click the variable in the Selected Variables list box and then choose the following actions:

- If the variable has options, they display in the Values list box. To select an option as the value for the variable, double-click the option.
- To specify a new value for the variable, click the Add Value button and enter a valid value in the Assigned Values list box.
- To specify an empty value for the variable, click the Down arrow next to the Add Value button and select Add Empty Value.
- When Delete Rows is selected, the Add All Values command is enabled. To delete all records with empty variable values, click the Down arrow next to the Add Value button and select Add All Values.

The values you specify display under the variable node in the Assigned value list box.

- 5 Specify a rule table behavior: add, override, or delete rows.
- 6 When applicable, you can select the Interpolation check box to allow interpolation in the rule table.
- 7 Click Finish to generate the rule table.

Editing Rule Tables

After a rule table is generated, edit it to maintain the general rule.

Fig. 5.26
Editing Rule Table

	IF: region:Value	IF: usage:Value	IF: power-converter:Value	THEN: pump:Value
1	Western Europe	industrial	standard	medium capacity
2	UK	domestic	smart	high capacity
3	Western Europe	domestic	standard	medium capacity
4	UK	industrial	smart	high capacity
5	USA	industrial	smart	high capacity
6	UK	domestic	standard	low capacity

To insert a row into the rule table, click the New button on the toolbar under the Rule Table tab.

To delete a row, click the Delete button.

Entering Data in Rule Table Cells

To enter a value in a cell:

First select the cell by positioning the cursor in it. You can then either enter the required expression in the cell, or use the option selection window.

The expressions you enter in a cell of the rule table must conform to the format rules that were defined for the rule tables. The exact choice of formats for a certain cell depends on the type of clause you are specifying and on the type of variable for which you are entering the expression. If you enter an expression that is not allowed, QAD Configurator will report this and you must change your entry. The following table lists all possible formats and their meaning.

Note [...] is used to exclude certain values from a range. Applying this information to the first five entries in the table will help you to understand the meaning of the entries in the other rows.

Table 5.3
Rule Table Formats

Entry	Meaning
value1	value1
value1 value2 value3	value1 or value2 or value3
value1:value2	\geq value1 and \leq value2
:value1	\leq value1
value1:	\geq value1
[value1]	not value1
[value1 value2 value3]	not value1 and not value2 and not value3
[value1:value2]	$<$ value1 or $>$ value2
[:value1]	$>$ value1
[value1:]	$<$ value1
[value1]:value2	$>$ value1 and \leq value2
[value1]:[value2]	$>$ value1 and $<$ value2
value1:[value2]	\geq value1 and $<$ value2
:[value1]	$<$ value1
[value1]:	$>$ value1
[[value1]:value2]	\leq value1 or $>$ value2

Entry	Meaning
[[value1]:[value2]]	<= value1 or >= value2
[value1:[value2]]	< value1 or >= value2
[:[value1]]	>= value1
[[value1]:]	<= value1

Note In the case of result variables, you can only use lists and exclusions if the type of the variable is text, numeric list, or date list and its attribute is value at the same time.

Using the Option Selection Window

The option selection window displays the options of the variable associated with the cell you are editing in the rule table to help you enter values for the variable. To bring up the option selection window, click the Options button on the toolbar.

Fig. 5.27
Option Selection Window

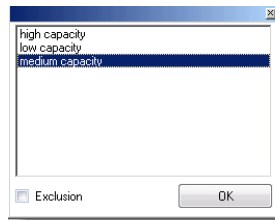

Numeric/Element. There is an extra fill-in field. Entering a value creates the condition/result variable = value.

Text/Numeric List. There is an extra fill-in field in which you can enter a value. The options of the variable are shown in a list. Entering a value creates the condition/result variable = value.

Date Current. There is an extra fill-in field, in which you can enter a date. The correct format is: two positions indicating the month, a slash, two positions indicating the day, another slash, and two positions indicating the year. Entering a value creates the condition/result variable = value.

Date Fixed. There is an extra fill-in field in which you can enter a date (format: see Date Current). The fixed date that was entered in Variable Maintenance is shown below the field in a list. Entering a value creates the condition/result variable = value.

Date List. There is an extra fill-in field in which you can enter a date (format: see Date Current). The options of the variable are shown in a list. Entering a value creates the condition/result variable = value.

Logical. There is an extra check box in the window. The variable, extent, and attribute to which it refers are shown next to it. Select the check box to enter the condition or result variable = yes in the table; deselect it to enter variable = no in the table. The variable is shown above the column; the cell will contain yes or no.

Select the Exclusion check box to indicate that you want to enter a condition or result of the type Variable <> value (the variable is NOT equal to the value you enter in the cell). This check box is dimmed in the case of THEN variables (except for the following types of THEN variables: text, numeric, date list, provided that their attribute is value) and in the case of an IF variable of the type logical, because using exclusions in these clauses would be meaningless.

Previewing Rules

To preview the rule defined by the selected row in the rule table:

Click the Preview button on the toolbar.

Fig. 5.28
Rule Preview

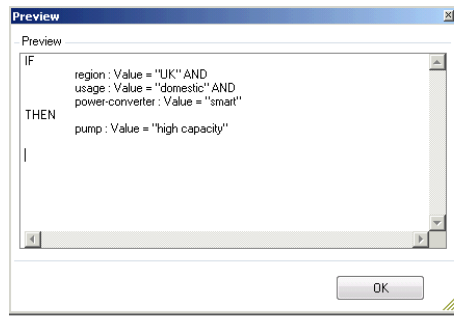

Accelerating Rule Tables

Click the Accelerator button if you want to prepare the table for accelerated searching. See “Accelerating Rule Tables” on page 92.

Maintaining Item Rule Tables

Use Item Rule Table Maintenance to link general rule tables to items and create item-specific rule tables.

Fig. 5.29
Item Rule Table Maintenance

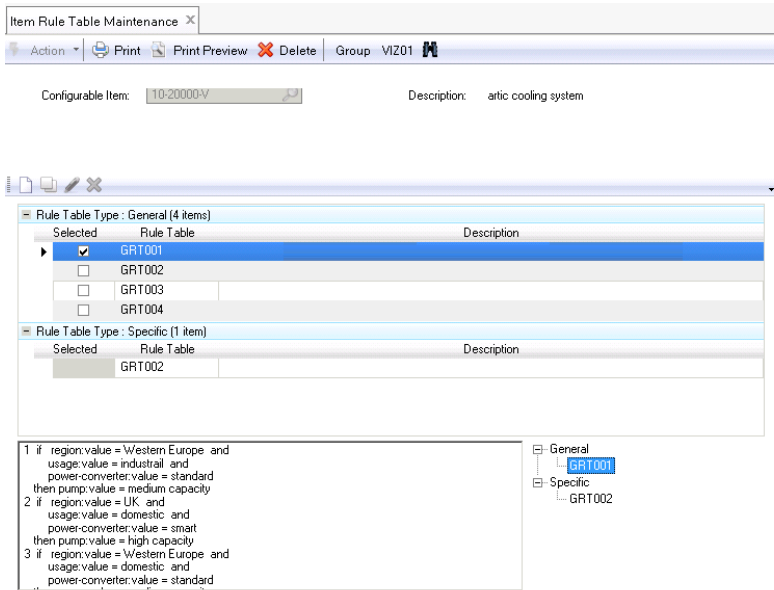

Linking General Rule Tables to Configurable Items

To link rule tables to a configurable item:

- 1 Enter an existing configurable item ID in the Configurable Item field.
- 2 All general rule tables in the current master group are listed. Click a rule table record to view its defined rule in the Preview pane.
- 3 Select the check box next to a rule table ID to link it to the current configurable item. Clear the check box next to a rule table ID to remove the link between it and the current configurable item. You can see selected rule tables grouped under the General Rule Table node in the Summary pane.
- 4 Click Save.

Maintaining Item-Specific Rule Tables

To create an item-specific rule table:

- 1 Enter an existing configurable item ID in the Configurable Item field.
- 2 Click the New button on the toolbar.
- 3 A Rule Table Maintenance window displays. Create a new rule or load an existing rule; then click OK. See “Maintaining General Rules Using General Rule Tables” on page 83.
- 4 The rule table is applied to the current configurable item as an item-specific rule table. You can see the rule table display in the item-specific rule table list as well as under the Item-Specific Rule Tables Node in the Summary pane.
- 5 Click Save.

To remove an Item-specific rule table:

Select the rule table in the item-specific rule table list and click the Delete button on the toolbar.

Accelerating Rule Tables

Use Rule Table Accelerator to make an indexed search on one or more rule tables possible. If you do not accelerate a rule table, you cannot perform an indexed search on that table.

When you accelerate a rule table, the Accelerator stores additional information needed for the indexed search in the database. Suppose that you use General Rule Table Maintenance to delete a rule table, and that you accelerated this same table sometime in the past. If QAD Configurator not only deleted the rule table itself, but also started searching the database for any corresponding additional information that may have become obsolete as a result, the deletion of the table would take quite some time. To avoid this, Rule Table Accelerator rather than General Rule Table Maintenance takes care of getting rid of this information. It starts searching the database and deleting the information as soon as it has finished accelerating the tables you specified.

Note The additional information will also become obsolete when the search mode for the rule table is switched from indexed to sequential. This happens whenever the data in the rule table is changed.

When a rule table has been accelerated, the system will automatically use an indexed search when searching the table. Rule Table Accelerator can also be used to undo the actions that made such an indexed search possible. Any obsolete information will then be deleted from the database and after that the system can only perform a sequential search.

Fig. 5.30
Rule Table Accelerator

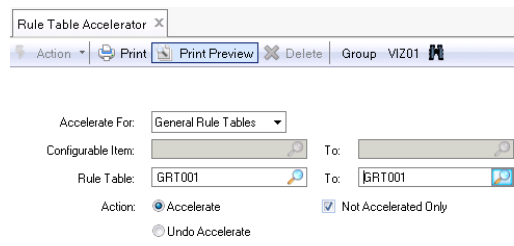

Rule Table Accelerator can operate on general rule tables or on item rule tables but it cannot accelerate both types of tables at the same time. Select general rule tables if you want to accelerate one or more general rule tables. Select item rule tables if you want to accelerate one or more item rule tables.

When you are accelerating item rule tables, you must also specify from which configurable items you want to accelerate the tables. You can specify one configurable item or a range of configurable items.

To indicate which tables you want to accelerate, specify a range by entering tables IDs in the From/To fields of the table ID frame. You can enter a value either by entering it directly in the field or by clicking the Browse button next to the field and selecting the required configurable item or table ID in the displayed list.

If you select both one or more configurable items and a range of table IDs, only the tables that satisfy both conditions will be accelerated or de-accelerated.

Select Accelerate if you want to accelerate one or more tables. If you want to switch from an indexed search to a sequential search, select Undo Acceleration. If you have undone an acceleration for a certain table and you want to use an indexed search on it, you must run Rule Table Accelerator—using Accelerate—for that table first.

Select the Not Accelerated Only check box if you only want to accelerate rule tables that have not yet been accelerated. Deselect this check box if you want to accelerate all rule tables that meet the criteria in the rule tables frame and the table ID frame.

Click Save to start the rule table accelerating process.

Sales Configuration Rules Report

Use Sales Configuration Rule Report to generate reports on sales configuration rules.

Fig. 5.31
Sales Configuration Rule Report

To run a sales configuration rules report:

- 1 Select a report category.
- 2 Specify the range of data and information you want to see on the report.
- 3 Specify additional report options, including report detail level, syntax options, and sorting options.
- 4 Click Run Report.
- 5 The report displays. Click Print to print the report; Click Save to save it to a file; click Close to close the report.

Analyzing Sales Configuration Rules

Use Configuration Analyzer to analyze sales configuration rules.

Fig. 5.32
Configuration Analyzer

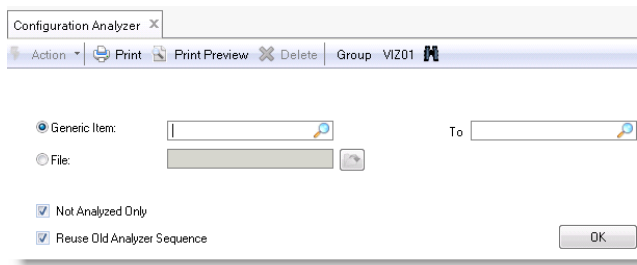

Configurable Item. Specify a configurable item or a range of configurable items to analyze.

File. Specify an ASCII file that contains the item numbers of the configurable items you want to analyze.

Not Analyzed Only. Select this check box to only analyze configurable items that have not been analyzed; otherwise, clear this check box.

Reuse Old Analyzer Sequence. Select this check box to reuse the sequences established by past analysis; otherwise, clear this check box.

Click OK to start analyzing.

When the analysis is complete, the system displays a report specifying the analyzed details of the selected configurable items. The report includes lower level configurable items within the configurable items you select, and gives details of the feature lists that will be used for the questionnaire. The report also identifies whether any configurable items were encountered for which no features or rules have been entered. You can print or save the report.

If no problems were encountered during the analysis, QAD Configurator updates the status of the analyzed configurable items by modifying the Analyzed fields in Configurable Item Maintenance.

If problems were encountered during the analysis, the status of the configurable item remains No in the Analyzed field.

Results of the Analysis

The Analyzer creates Progress source and object code to be run by the questionnaire. This source and object code contains the Inclusion and Exclusion logic as defined by the rule maintenance functions and the rule tables.

The object code files are stored in the directory that was defined as the questionnaire object directory in Configurator Control.

Each configurable item has a unique 6-digit object code number (pcpt_rcode). This code is used to create the object code file names and directories specific to that configurable item.

Example Consider a configurable item, G1, with an object code number 000100. The directory structure for the object code files looks like this:

```
c:\mfg84gus\mfgdemo\qu000100.r
  \qu000100\qu0001.r
  \qu000100\qu0002.r
  ....
```

The first line specifies the configurable item control program; the following lines specify the feature/rule files 0001 to 9999.

For performance reasons, a maximum of 10 features are included in each feature/rule file; then a new file is created. These feature/rule files are stored together in the directory with the object code number preceded by qu.

The control program takes care of the process of finding the correct feature/rule file for the questionnaire.

The feature/rule object files (with the .r extension) for a configurable item can be deleted, for example, using the Windows File Manager/Explorer, without any problem. The QAD Configurator Analyzer will create them or refresh them automatically when they are next needed.

When there is any doubt about the validity of the object codes, you should always delete them and run the Analyzer again to rebuild them.

Maintaining Questions Sequence

The sequence in which questions are presented in the questionnaire is determined by the Analyzer. Questionnaire Sequence Maintenance lets you manually rearrange the questions.

Fig. 5.33
Questionnaire Sequence Maintenance

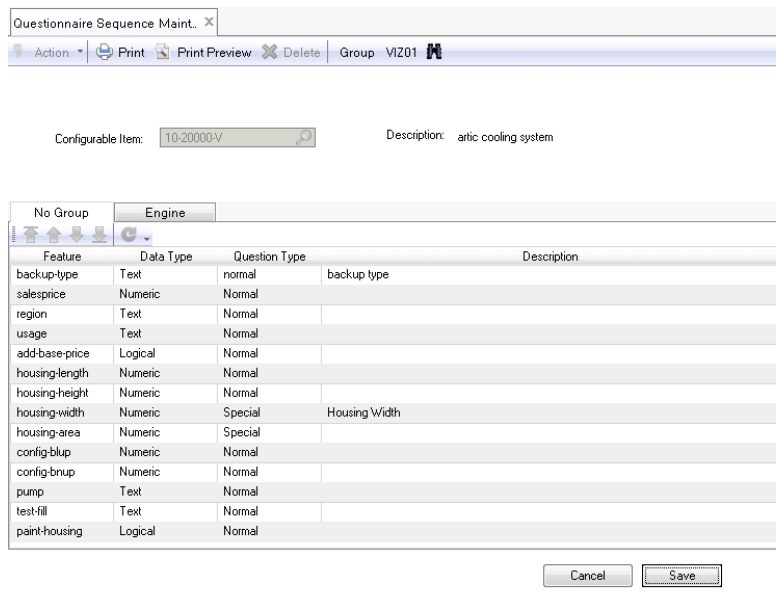

To arrange the question sequence in the questionnaire:

Select a configurable item and use the commands on the toolbar to change the order of the item's features in the feature list. If there are multiple feature groups, click on the function group tabs to switch among them.

Maintaining Configuration Keys

Use Configuration Key Maintenance to specify key features for configurable items that identify unique configurations.

In order to identify unique configurations, and therefore, unique variant items, you must specify for each configurable item the features that will be used to determine whether a particular configuration is unique.

You can specify up to twenty features for a configurable item that together form a configuration key. When you run the questionnaire for this item, QAD Configurator examines the options chosen for the configuration key features for previous configurations and compare them with the equivalent options chosen for the current configuration. In this way, you can avoid duplication of configurations and variants.

Fig. 5.34
Configuration Key Maintenance

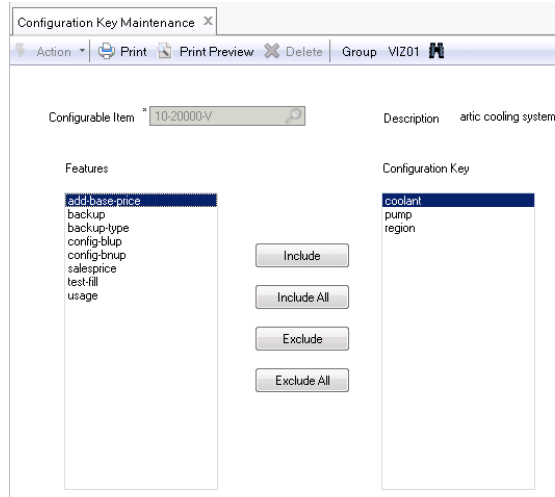

To specify configuration keys for a configurable item:

- 1 Specify a configurable item in the Configurable Item field.
- 2 To set a feature as a configuration key, select it in the Features list box and click Include to move it to the Configuration Keys list box. Click Include All to set all available features as configuration keys.

To remove a configuration key, select it in the Configuration list box and click Exclude to move it to the Feature list box. Click Exclude All to remove all configuration keys.

- 3 Click Save.

Configuration Key Maintenance and Pricing

In models where pricing is used, it is strongly recommended that you include the customer and all features that are used in pricing rules as key features. This is because prices may depend on the customer and quantities of components ordered.

Where-Used Report

The Where-Used Report provides information on where variables are used in QAD Configurator; that is, which configurable items in which groups use each variable.

Fig. 5.35
Where-Used Report

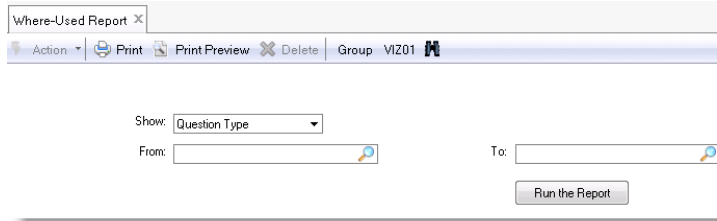

To run a where-used report:

- 1 Specify the element you want in the report:
 - Question type
 - Rule group
 - Variable
 - Feature
 - Rule
 - Configurable item

Note If you choose Configurable item, planning items will also be displayed in a separate section of the report.

- 2 Specify an ID or a range.
- 3 Run the report. The report opens and you can print or save it.

Product Configuration

Product Configuration Overview 100

Outlines the product configuration process.

Maintaining Product Configuration Rules 101

Explains how to maintain variant item number rules, variant item data rules, variant item product structure rules, variant routing rules, variant sales order line rules, and variant sales quote line rules.

Maintaining General Product Structure Rules 112

Explains how to use General Product Structure Rule Maintenance.

Running Product Configuration Rule Report 116

Explains how to use Element Roll-Up Rule Maintenance.

Maintaining External Entity Rules 114

Explains how to use External Entity Rule Maintenance.

Using Custom Functions in Product Configuration Rules 115

Describes the system's rules for allowing the user to define and maintain custom functions and use them in product configuration rules.

Running Product Configuration Rule Report 116

Explains how to run Product Configuration Rule Report.

Cross-Validating Rules 117

Explains how to use Cross-Validation Analyzer.

Product Configuration Overview

In the product configuration process, engineering personnel define product configuration rules that translate feature data collected from questionnaires into product structures and routings of configured products.

Fig. 6.1
Product Configuration Process

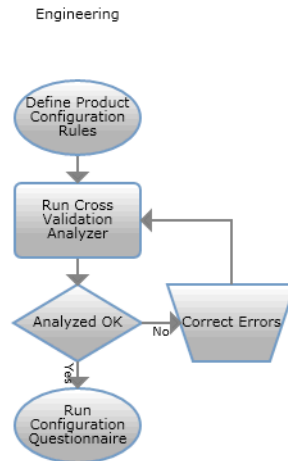

Product configuration rules include the following rules that the system runs and applies at different stages of the variant creation process during order entry, as illustrated in the diagram below:

- Variant item number rules
- Variant item data rules
- Variant planning item rules
- Variant product structure rules
- Variant routing rules
- Variant sales order line rules
- Variant sales quote line rules
- General product structure rules
- Element roll-up rule
- External entity rules

Fig. 6.2
Variant Item Creation and Sales Order/Quote Generation Process

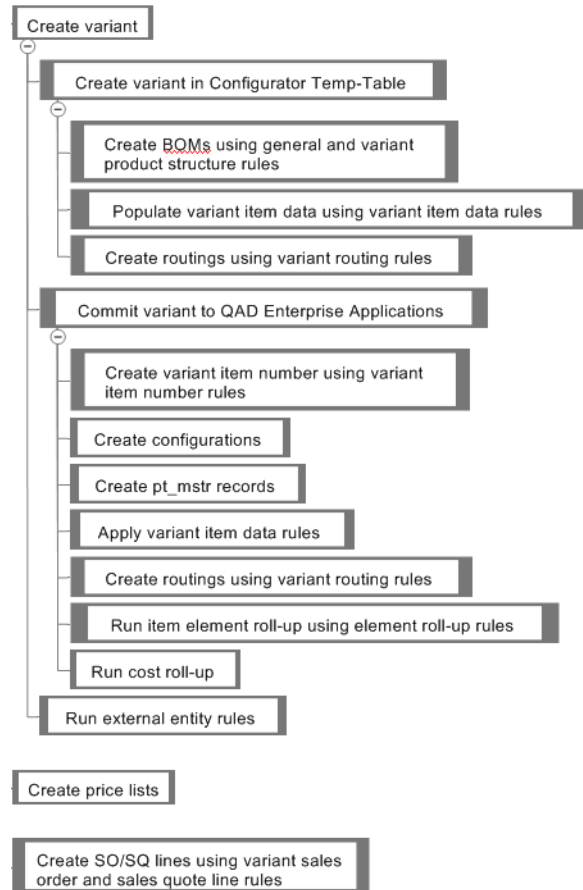

Maintaining Product Configuration Rules

Maintaining Variant Item Number Rules

Use Variant Item Number Rule Maintenance to define how QAD Configurator assigns item numbers to new variant items. You do this by defining definition rules for each configurable item from which you intend to create variant items. That is, for items for which you run the questionnaire, and for every lower level configurable item in the product structure, because variants of these lower level items are created in the same process.

A variant item number rule can be a combination of the following elements:

- Fixed: a string of characters that does not vary with variant item
- Character: a separator between elements of the number, such as a hyphen (-)
- Current Configurable Item: the number of the current configurable item
- Master Configurable Item: the number of the top level configurable item
- Field: an QAD EA database element field name
- Feature: a selected feature for the variant item

- Alphanumeric Sequence: alphabetically sequenced character, incremented for each variant item.
- Numeric Sequence: a sequential number, incremented for each variant item

Every component except alphanumeric sequence and numeric sequence can be used more than once in a rule, provided that the total length of the number does not exceed 18 character positions, which is the maximum field length in QAD EA.

Fig. 6.3
Variant Item Number Rule Maintenance

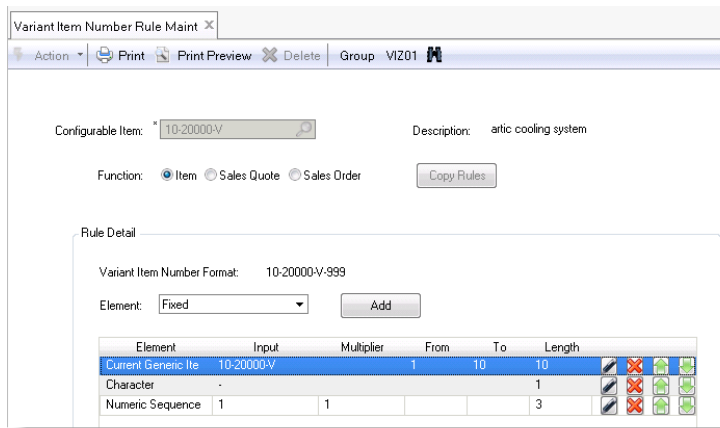

To edit a variant item number rule:

- 1 Specify a configurable item in the Configurable Item field.
- 2 Select from three different variant item number rules. Each Function option represents the point from which a variant item can be created: item (the Variant Product Structure/Routing Generator), sales quote, or sales order. Each configurable item can have up to three different variant item numbering rules.
- 3 To copy from an existing rule, click the Copy button. In the Copy Rule window, specify a configurable item and select a function option; then click OK. The selected rule will be duplicated to the current rule.
- 4 Edit the rule element list in the Rule Details pane.
 - To add an element to the list, select an element from the Element drop-down list and click OK. In the pop-up window, supply the value and parameters and click OK. You cannot add more than one numeric sequence and alphanumeric sequence element to a format.

Table 6.1
Variant Item Number Definition Parameters

Component	Parameters to complete in the subsidiary window
Fixed	Fixed string of characters.
Character	Separator to use between elements of the number. The default is a hyphen (-), but you can specify another separator if required.
Current Configurable Item	Position from and position to; the specified positions are copied from the current configurable item number.

Component	Parameters to complete in the subsidiary window
Master Configurable Item	Position from and position to; the specified positions are copied from the top level configurable item number.
Field	The QAD EA database element field name; the position from and the position to; the character values in the specified positions are copied from the specified field.
Feature	The feature; the position from and the position to: the character values in the specified positions are copied from the value selected for this feature in the questionnaire for the variant item.
Alphanumeric Sequence	Length, multiplier (increment), and start value.
Numeric Sequence	Length, multiplier (increment), and start value.

- To remove an element from the list, select it in the list and click the Remove button.
- To adjust the order of elements in the list, click use the Up and Down arrows.

5 Once you make changes to the rule elements, the resulting variant item number format display in real time above the element list, using the character 9 to represent numbers and x to represent alphabetical characters. Review the format.

6 Click Save to save the current rule.

Example A variant item number definition rule consists of the following elements:

- Current Configurable Item: positions 1 to 5
- Character: –
- Feature: color, positions 1 to 3
- Character: /
- Numeric Sequence: length 3, multiplier 1, start value 1

If the current configurable item is 3-100-150, and the color selected for the first variant item is tropical blue, the first variant item number will be:

3-100-tro/001

If the color for the second variant item is sunset orange, the second variant item number will be:

3-100-sun/002

Maintaining Variant Item Data Rules

Use Variant Item Data Maintenance to assign values to database fields in newly created variant items. You do this by defining assignment rules for the configurable item, which specify how the values are to be assigned to the database fields. When the Variant Product Structure/Routing Generator creates a variant item for that particular configurable item, it applies the assignment rules defined for that item in order to assign the required database values to the specified fields.

After a variant item has been created by QAD Configurator, you can carry out any further maintenance of the database field values for the new item using the QAD EA Item Master Maintenance function.

Fig. 6.4
Variant Item Data Rule Maintenance

Maintaining Variant Planning Item Rules

Use Variant Planning Item Rule Maintenance to define variant planning item selection rules for non-kit configurable items. Variant planning items are used to consume forecast when confirmed sales orders are created for variant items. For configurable items that are physical or phantom kits, when you generate variant items from them, the system adds components of their variant items to the `mrp_det` table so that they also consume forecasts upon sales order confirm.

When you create a variant item by either creating a new configuration or modifying an existing one, the system runs the variant planning item rule to add the variant item to the product structure of the planning item as a component with the following values:

- Structure Type = “P” (planning)
- Forecast Percent = zero to prevent MRP from generating planned orders for the components of the variant item from the forecast of the planning item.
- Quantity Per = 1

Because Structure Type = “P”, the system will consume the forecast of the planning item with the variant item order quantity on the sales order line.

When the variant is put on a sales order line and confirmed, the forecast of the planning item, if set up, is consumed by the variant order quantity.

For a multi-level product structure, there can be multiple configurable items with their own planning items and selection rules.

- 1 Specify an existing configurable item and press Enter. The item cannot be a physical or phantom kit. The system validates the item number and displays an error message when:
 - The item does not exist.
 - The item is not a configurable item.
 - The configurable item is a physical or phantom kit.
- 2 Click the New icon to create a new planning item and define selection rule for it. The selection rule in Variant Planning Item Rule Maintenance is optional and if it is left blank, the system will always add variant items to the planning bill of the specified planning item.

To edit a selection rule:

You can either manually type the rule by directly typing the statements in the Rule box or use the Rule Assistant to assist you in the process. See “Using the Rule Assistant” on page 35.

Click Check Syntax to validate the rule syntax. If syntax errors are found, error messages display and the Status becomes Failed.

Click Save to save the rule. On saving the rule, the system performs a syntax check on the rule. If syntax errors are found, error messages display.

Fig. 6.5
Variant Planning Item Rule Maintenance

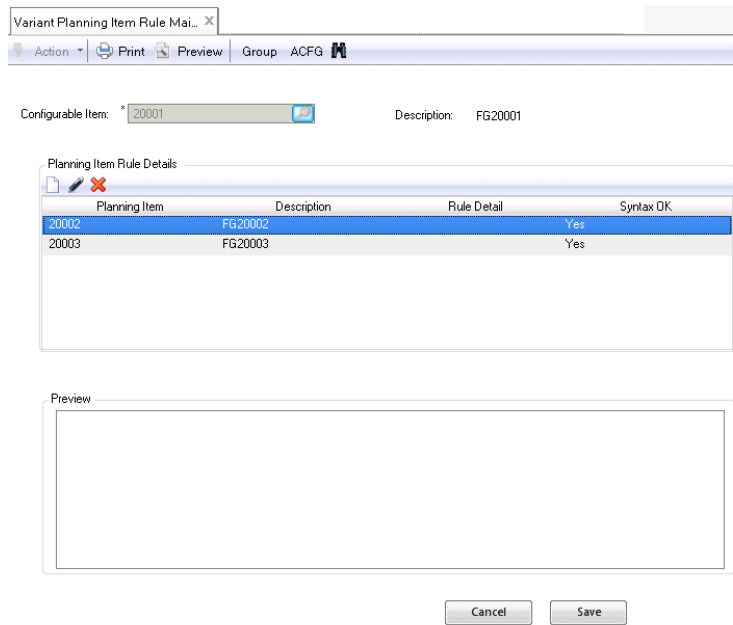

Maintaining Variant Item Product Structure Rules

Use Variant Product Structure Rule Maintenance to define selection and assignment rules for component items in the generic product structure.

If no selection rule has been defined for a component in the generic product structure, the component will always be selected into the variant product structure, unless its parent item is excluded from the variant product structure by its selection rules.

Fig. 6.6
Variant Product Structure Rule Maintenance

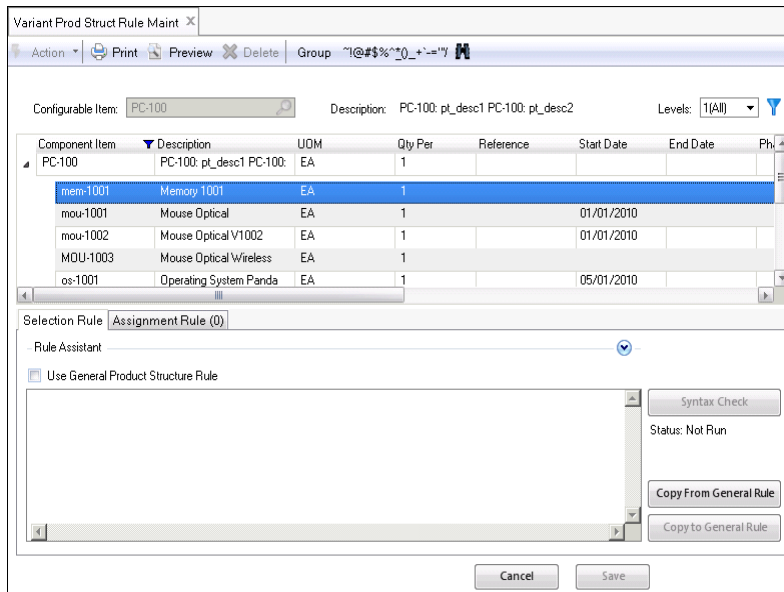

To select a component item in a configurable item product structure:

- 1 Specify a configurable item number in the Configurable Item field. The item's description displays next to the configurable item number.
- 2 If the configurable item has a multi-level product structure, do one of the following to view its child components:
 - Select the number of levels you want to expand the product structure in the Levels drop-down list.
 - Click the left arrow next to a parent component to display its sub-components.

If a component already has selection and assignment rules defined, they are displayed in the Selection Rule and Assignment Rule columns respectively in the product structure table.

- 3 You can filter the components in the generic product structure.

To filter the components:

Click the Filter icon next to the Levels drop-down list; then specify in the Filter window which type of components you want to display in the generic product structure.

Fig. 6.7
Variant Product Structure Rule Filter

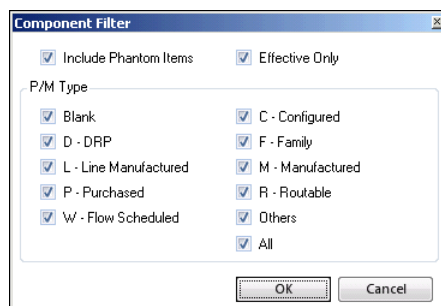

P/M Type. Select the type of items to display as defined in QAD EA. See QAD EA documentation for descriptions of these item types.

Include Phantom Items. Clear this check box to exclude phantom items when displaying specified P/M types of items; otherwise, select this check box.

Effective Only. Select this check box to filter items using their effective start and end dates. Items considered effective must meet the following criteria:

Effective Start Date <= Today <= Effective End Date

Items with no effective start and end dates defined will always be displayed.

Note The default filter settings are defined in Master Group Maintenance.

Click OK to apply the filter.

- 4 Click the component whose selection rule or assignment rule you want to edit.

Defining Selection Rules

Define selection rules under the Selection Rule Tab. When defining a selection rule, you may have three options:

- Create a selection rule from scratch
- Use a general selection rule. General selection rules are defined in General Product Structure Rules Maintenance.
- Create a selection rule based on a general selection rule.

To edit a selection rule:

You can either manually enter the rule by directly typing the statements in the Rule box or use the Rule Assistant to assist you in the process. See “Using the Rule Assistant” on page 35.

Click Syntax Check to validate the rule syntax. If syntax errors are found, error messages display and the Status becomes Failed.

Click Save to save the rule. On saving the rule, the system performs a syntax check on the rule. If syntax errors are found, error messages display.

To use a general selection rule:

Select Use General Product Structure Rule above the Selection Rule box. When a general selection rule is found, it displays in non-editable mode in the Selection Rule box after you confirm to overwrite the existing selection rule. If no general selection rule has been defined for this item, the system informs you that no general selection rule is available.

To copy from a general selection rule:

Click the Copy from General Rule button to duplicate the general selection rule into the Selection Rule box. If no general selection rule has been defined for this item, the system informs you that no general selection rule is available.

To copy a selection rule to the general selection rule:

Click the Copy to General Rule button. If no general selection rule has been defined for the item, the current selection rule is duplicated to the general selection rule. If a general selection rule already exists for the item, the system notifies you that you cannot overwrite the existing general selection rule. The general selection rule you create this way can be maintained in General Product Structure Rule Maintenance.

Defining Assignment Rules

Define assignment rules under the Assignment Rule tab. The Assignment Rule tab displays the number of assignment rules for your reference. You can define multiple assignment rules for a component.

Fig. 6.8
Assignment Rule List

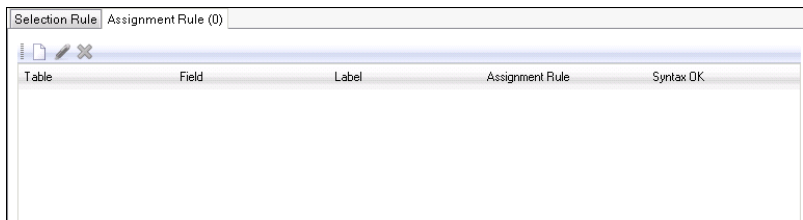

To create a new assignment rule:

- 1 Click the New button on the toolbar above the assignment rule list. The Assignment Rule Maintenance window displays.

Fig. 6.9
Assignment Rule Maintenance

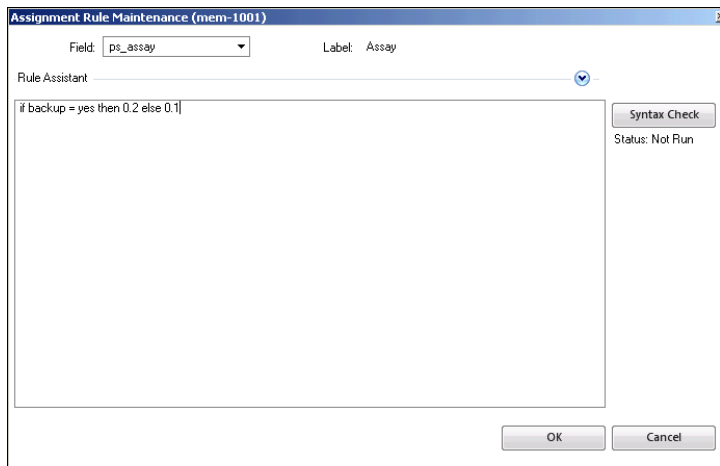

- 2 Specify a field to which to apply the assignment rule from the Field list, which contains all the fields in the product structure table (ps_mstr) in QAD EA.
- 3 Compose the assignment rule with the assistance of the Rule Assistant. See “Using the Rule Assistant” on page 35.

- 4 Click Check Syntax to validate the rule syntax. If syntax errors are found, error messages display and the Status becomes Failed. The assignment rule still can be saved without having to pass the syntax check.
- 5 Click OK to save the rule and close the window.

To specify the assignment rule for multiple fields:

Use the drop-down list located next to the Field field to move from field to field for specifying the assignment rules.

To open an existing assignment rule for editing:

Double-click the assignment rule in the assignment rule list or select it and click the Modify button on the toolbar.

To delete an existing assignment rule:

Select the assignment rule in the assignment rule list and click the Delete button on the toolbar.

Maintaining Variant Routing Rules

Use Variant Routing Rule Maintenance to define selection and assignment rules for operations in the generic routing.

If no selection rule has been defined for an operation in the generic routing, the operation will always be selected into the variant product structure.

Fig. 6.10
Variant Routing Rule Maintenance

Variant Routing Rule Maint

Action Print Print Preview Delete Group VIZ01

Configurable Item* 10-20000-Y Description: artic cooling system

Operation	Description	Machine	Start Effective	Selection Rule	Assignment Rule
10	assembly				
20	inspection				Yes

Selection Rule Assignment Rule

Table	Label	Field	Assignment Rule
ro_det	Run Time	ro_run	if backup = yes then 0.2 else 0.1

Cancel Save

To select an operation of a generic routing:

- 1 Specify a configurable item number in the Configurable Item field. The item’s description displays next to the configurable item number. The routing table below lists all the operations in the item’s generic routing.
If an operation already has selection and assignment rules defined, they display in the Selection Rule and Assignment Rule columns respectively in the generic routing table.
- 2 Click the operation whose selection rule or assignment rule you want to edit.

Defining Selection Rules

Define selection rules under the Selection Rule Tab.

To edit a selection rule:

- 1 Type the rule in the Selection Rule box. Use the Rule Assistant to assist you in the process. See “Using the Rule Assistant” on page 35.
- 2 Click Check Syntax to validate the rule syntax. If syntax check is successful, Status changes from Not Run to Passed. If syntax errors are found, error messages display and Status changes from Not Run to Failed.
- 3 Click Save to save the rule. On saving the rule, the system performs a syntax check on the rule. If syntax errors are found, error messages display.

Defining Assignment Rules

Define assignment rules under the Assignment Rule tab. You can define multiple assignment rules for an operation.

Fig. 6.11
Assignment Rule List

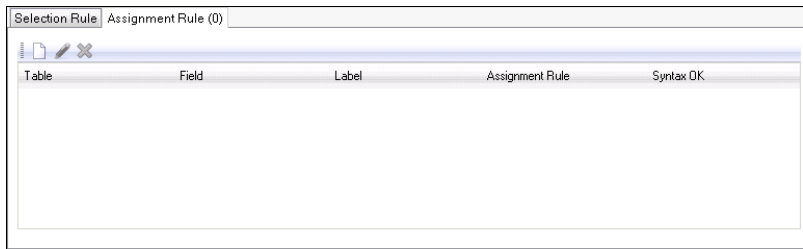

To create a new assignment rule:

- 1 Click the New button on the toolbar above the assignment rule list. The Assignment Rule Maintenance window displays.

Fig. 6.12
Assignment Rule Maintenance

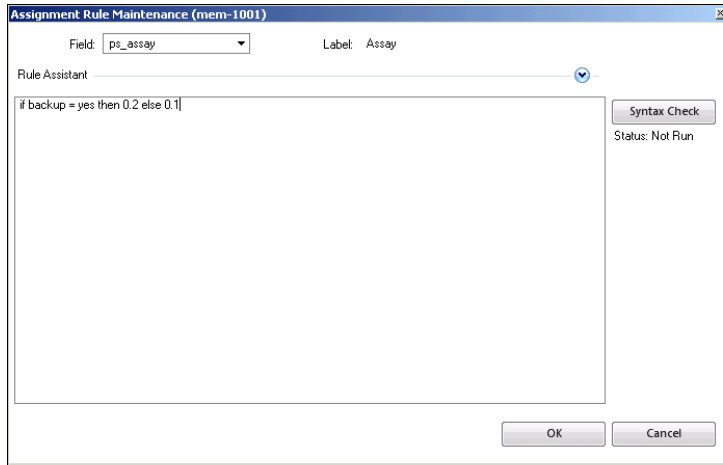

- 2 Specify a field to which to apply the assignment rule from the Field list, which contains all the fields in the routing detail table (ro_det) in QAD EA.
- 3 Compose the assignment rule with the assistance of the Rule Assistant. See “Using the Rule Assistant” on page 35.
- 4 Click Check Syntax to validate the rule syntax. If syntax errors are found, error messages display and the Status becomes Failed.
- 5 Click OK to save the rule and close the window; click OK and Create to save the rule and create another rule. On saving the rule, the system performs a syntax check on the rule. If syntax errors are found, error messages display.

To view or edit an existing rule:

Double-click the assignment rule in the assignment rule list or select it and click the Modify button on the toolbar.

To delete an existing assignment rule:

Select the assignment rule in the assignment rule list and click the Delete button on the toolbar.

Maintaining Variant Sales Order Line Rules

Use Variant SO Line Rule Maintenance to define assignment rules for a configurable item to assign values to sales order details fields of newly created variant item records.

Note To ensure data validity for the correct business logic in Sales Order Maintenance, you can only assign values to those sales order details fields that do not have default values or calculation logic, such as sod_qty_ord. Fields like sod_site and sod_price will be overwritten by the QAD EA business logic even if you have assigned values to them through assignment rules.

To define a sales order line rule:

- 1 Specify a configurable item in the Configurable Item field.
- 2 Specify a sales order details field with an sod prefix in the Field field.
- 3 Compose the assignment rule with the assistance of the Rule Assistant. See “Using the Rule Assistant” on page 35.
- 4 Click Check Syntax to validate the rule syntax. If syntax errors are found, error messages display and the Status becomes Failed.

Maintaining Variant Sales Quote Line Rules

Use Variant SQ Line Rule Maintenance to define assignment rules for a configurable item to assign values to sales quote details fields of newly created variant item records.

Note To ensure data validity for the correct business logic in Sales Quote Maintenance, you can only assign values to those sales quote details fields that do not have default values or calculation logic, such as qod_desc. Fields like qod_status and qod_price will be overwritten by the QAD EA business logic even if you have assigned values to them through assignment rules.

To define a sales quote line rule:

- 1 Specify a configurable item in the Configurable Item field.
- 2 Specify a sales quote details field with an qod prefix in the Field field.
- 3 Compose the assignment rule with the assistance of the Rule Assistant. See “Using the Rule Assistant” on page 35.
- 4 Click Check Syntax to validate the rule syntax. If syntax errors are found, error messages display and the Status becomes Failed.

Maintaining General Product Structure Rules

Use General Product Structure Rule Maintenance to define general selection rules for selecting components into variant product structures that are not specific to configurable items.

Fig. 6.13
General Product Structure Rule Maintenance

General Prod Struct Rule Maint

Action Print Print Preview Delete Group V5EA

Component: 44-3000 Description: Standard Power Converter

Rule Assistant

Selection Rule: usage = "domestic" Check Syntax

Status: Passed

To edit a selection rule:

- 1 Specify a component item number in the Component field.
- 2 Type the rule in the rule box. Use The Rule Assistant to assist you in composing the rule. See “Using the Rule Assistant” on page 35.

Note When using the Rule Assistant General Product Structure Rule Maintenance, an “Unknown Answer” option is available in the Variable Option list. This element translates into `/* Unknown Answer */` in the selection rule statement and is used to accept user-provided values that are not valid configurable item features into the selection rule.

- 3 Click Check Syntax to validate the rule syntax. If syntax check is successful, Status changes from Not Run to Passed. If syntax errors are found, error messages display and Status changes from Not Run to Failed.
- 4 Click Save to save the rule. On saving the rule, the system performs a syntax check on the rule. If syntax errors are found, error messages display.

Maintaining Element Roll-Up Rules

Use Element Roll-Up Rule Maintenance to define rules for rolling up non-cost-related data elements when generating variant items.

Fig. 6.14
Element Roll-Up Rule Maintenance

Master Element (pt_mstr). Specify the database field in the item master table (pt_mstr) to which you want to roll up data elements. Whenever a variant item is created and data elements are rolled up according to element roll-up rule, the resultant rolled-up value will be stored in this field of the variant item record in the item master table. An item master table field uniquely identifies an element roll-up rule.

Take Product Structure Quantities into Account. Select this check box if you want QAD Configurator to automatically correct rolled-up values to take into account required component quantities as defined in the product structure (ps_qty_per).

Rule Type. Select whether you want to edit a simple rule in basic mode or a more complex rule in advanced mode.

Roll-Up Type. Select Product Structure to roll up component-related data or select Routing to roll up routing-related data.

To edit a simple rule:

Specify a field data to roll up in a simple rule.

Roll-Up Data. Select a table.

If you selected the Product Data roll-up type, you can choose from the item master table (pt_mstr) or the product structure master table (ps_mstr) from the drop-down list.

If you selected the Routing roll-up type, you can choose from the work center master table (wc_mstr) or the routing operation detail (ro_det) table.

Roll-Up Element. Select the field whose data you want to roll up.

To edit an advanced rule:

- 1 Type the rule in the rule box. Use The Rule Assistant to assist you in composing the rule. See “Using the Rule Assistant” on page 35.
- 2 Click Check Syntax to validate the rule syntax. If syntax check is successful, Status changes from Not Run to Passed. If syntax errors are found, error messages display and Status changes from Not Run to Failed.
- 3 Click Save to save the rule. On saving the rule, the system performs a syntax check on the rule. If syntax errors are found, error messages display.

Maintaining External Entity Rules

Use External Entity Rule Maintenance to assign values to fields in databases defined as external entities. For information on defining external entities, see “Maintaining External Entities” on page 55.

Fig. 6.15
External Entity Rule Maintenance

External Entity Rule Maintenance

External Entity: desc01 Description:

Database: qaddb

Table: pt_mstr Description: Item Master

Field	Description	Progress Database	Syntax Check	Assignment Rule
oid_pt_mstr	Unique application	<input checked="" type="checkbox"/>		
pt_chr01	User custom char	<input checked="" type="checkbox"/>		
pt_chr02	User custom char	<input checked="" type="checkbox"/>		
pt_chr03	User custom char	<input checked="" type="checkbox"/>		
pt_chr04	User custom char	<input checked="" type="checkbox"/>		

Rule Assistant

pt_chr03 =

Progress Database

Update

Check Syntax

Status: Not Run

Cancel Save

To assign values to entity fields:

- 1 Specify a previously defined external entity. Its database and table information is displayed below.
- 2 Click on a field in the Database Field list to select it.
- 3 In the Progress Database column, specify whether your QAD EA is running on the Progress database.

Select the check box when QAD EA is running on the Progress database. Values will be assigned to the selected field in the Progress database based on assignment rule without any truncation.

Clear the check box when you are using a database other than Progress. The system will automatically truncate values assigned to the selected field if the value string exceeds the maximum length allowed for that field.

- 4 Edit the assignment rule for the selected field.
 - a Type the rule in the rule box. Use The Rule Assistant to assist you in composing the rule. See “Using the Rule Assistant” on page 35.
Variables you select must be defined as Features within the given Item; otherwise, error msg to ask whether convert the variables to Features, if yes, then map the variables to the features of the configurable item; while if no, the rule cannot be saved.
 - b Click Check Syntax to validate the rule syntax. If syntax check is successful, Status changes from Not Run to Passed. If syntax errors are found, error messages display and Status changes from Not Run to Failed.
 - c Click Update to display the rule and its syntax check status in the Database Field list. On updating the rule, the system performs a syntax check on the rule. If syntax errors are found, error messages appear.
- 5 Repeat steps 2 through 4 to define rules for multiple fields.
- 6 Click Save to save all the changes.

Using Custom Functions in Product Configuration Rules

The system lets you easily define and maintain custom functions in the `pccop.i` file and use them in the following product configuration rules:

- Variant item data rules (assignment rules)
- Variant product structure rules (selection rules and assignment rules)
- Variant routing rules (selection rules and assignment rules)
- Variant SO line rules (assignment rules)
- Variant SQ Line rules (assignment rules)
- External entity rules (assignment rules)
- General product structure rules (selection rules)

Custom functions are called and executed when the system processes the rules containing them.

To use a custom function:

- 1 Edit the `pccop.i` file to define your custom function using Progress. Here is a sample function:

```
function AddDesc return character (input cName as character):
    return "This is a new variant of item " + cName.
end function.
```

- 2 When defining product configuration rules, you can use the custom function by passing parameters to it; for example, assign the following to the `pt_desc1` field of a particular configurable item:

```
AddDesc ("A01")
```
- 3 Use Check Syntax to validate both the rule and the custom function.
- 4 When the system applies the rule to the variant item generation process, the function is executed and returns a value. In the previous example, the description of the new variant item would be “This is a new variant of item A01.”

- 5 Whenever there are any changes to the custom function in `pccop.i`, you need to run Batch Compiler for the configurable item to make the changes effective.

Running Product Configuration Rule Report

Run Product Configuration Rule Report to view detailed product configuration rule information.

This function lets you generate reports that display any types of product configuration rules associated with a specific range of configurable items and components. You can also choose whether to show validated rules or rules that have failed validation, or both. This is a very useful tool for you to manage and analyze product configuration rules.

Fig. 6.16
Product Configuration Rule Report

Cross-Validating Rules

Use Cross Validation Analyzer to check if the product configuration rules and rules match features and rules in sales configuration. This analyzer detects any discrepancies between the two modules and produces a report.

Fig. 6.17
Cross Validation Analyzer

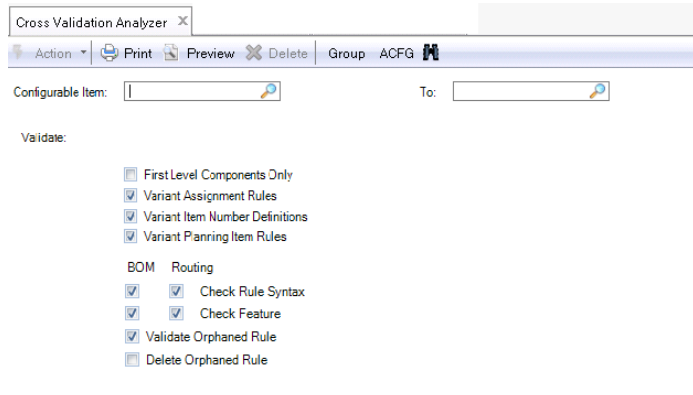

To perform a cross validation:

Configurable Item/To. Specify a configurable item or a range of configurable items for which you want to run rule cross validation. When left blank, the check will be performed for all configurable items.

First Level Component Only. Select this option if you want to only perform cross-validation only for the first level of components in a generic product structure; Otherwise, the system performs cross-validation for all levels of components in the generic product structure.

Variant Assignment Rules. Specify whether to check variant assignment rules.

Variant Item Number Definitions. Specify whether to check if a variant item number exists for every configurable item in the generic product structure.

BOM, Routing, Rule Syntax, Features. Select the rules and/or features you want to check for.

The routing checks will only be available if the Routings field is selected in Master Group Maintenance for the group.

Validate Orphaned Rule, Delete Orphaned Rule. Select these two options if you want to validate and delete the orphaned rules. Currently these two options are only for product structure (BOM) rules and not for routing rules.

Click OK to run the Cross Validation Analyzer. When the analysis is complete, an analysis report displays.

Configuration Questionnaire

Launching Questionnaire 120

Describes the contents of the questionnaire window.

Navigating in Questionnaire 120

Describes the default organization of the questionnaire UI.

Exiting Questionnaire 122

Explains how to exit the questionnaire module.

Variant Item Configuration Workflow 123

Illustrates the workflow and describes the steps required to configure a variant item.

Using Standard/Existing Configurations 125

Explains how to use the Existing Configurations tab, browse through configurations, search for configurations, order an existing variant item, create a variant item from existing configurations, load an existing configuration, and create a new configuration.

Configuring Item 129

Describes the Configure Item screen and details how to answer questions, review answer summaries, edit comments, and customize the questionnaire.

Reviewing and Submitting Configuration 133

Explains how to use the Configuration Summary Screen, review current configurations, view similar configurations, and submit configurations.

Launching Questionnaire

There are two ways you can launch questionnaire.

- Use Configuration Questionnaire.
- Select a configurable item in the order line in Sales Order Maintenance (7.1.1) or Sales Quote Maintenance (7.12.1). The Questionnaire window is automatically launched. Selecting a variant item in the order line does not trigger the product configuration process.

Fig. 7.1
Questionnaire Window

All standard configurations for Item 01040		
Configuration ID	00001091	00001041
Variant Item	01040-055	01040-051
Customer	ATEST01	
Status	F	F
Create date	12/11/11	12/07/11
User ID	CSS_demo	mfg
Description		
List Price (USD)	3,344.05	3,112.55
Net Price (USD)	3,344.05	3,112.55
Backup (Short)	Yes	No
Backup Type (Short)	Alkaline	N.A.
Printer	Yes	No
Keyboard Cover	Yes	No
Length	60	60
Display Type	Top Display	Front Display
Height	120	120
Width	60	160
Area	36,000	72,000
Qty - Large Steel	0	1
Qty - Small Steel	4	1
Color	Black	Black
Item Description	Industrial Ultrasound	Industrial Ultrasound
CPU	Standard	High
Frequency	500 KHZ	10 MHZ

The title bar of the Configuration Questionnaire window displays the following information:

Group. The group that the configurable item you are configuring belongs to. Groups are defined using QAD Configurator's Master Group Maintenance function.

Customer. Shows which customer you are configuring the item for. This is the same customer ID in the Sold-To field in the header of the sales order or sales quote from which Questionnaire was launched.

Item. Shows the configurable item that you are configuring. This is the same configurable item number that you selected in Sales Order Maintenance (7.1.1) or Sales Quote Maintenance (7.12.1).

Navigating in Questionnaire

The Configuration Questionnaire user interface organizes task-oriented information under the following tabs:

- Standard Configurations
- Existing Configurations
- Configure Item

- Configuration Summary

By default, when the Questionnaire window is launched, you see the Existing Configurations screen first. The Configure Item and Configuration Summary tabs are disabled; after you reload a configuration or create a new configuration, you can then switch to these two tabs. However, by using the Show Existing Configurations option in Configurable Item Maintenance, you can specify whether you want to see the Existing Configurations screen first.

Show Existing Configurations. Specify whether and how to display existing configurations in the questionnaire:

- First: Display existing configurations on launching the questionnaire.
- Second: Display the new configuration on launching the questionnaire.
- On request: When launching the questionnaire, display a message asking the user whether to show existing configurations.
- No: Hide the Existing Configurations tab in the questionnaire.

The Standard Configurations screen shows the standard configurations, which are configurations recommended by the manufacturer to make it easier for a customer to order configured items. For example, standard configurations can be popularly ordered configurations in the past, or some particular configurations that a marketing campaign wants to promote. See “Maintaining Standard Configurations” on page 153 for more information about standard configurations.

The following diagram depicts all possible navigation flows of screens in your configuration process. Squares represent Questionnaire screens, lines represent actions that trigger flows among screens, and the diamond represents the Show Existing Configurations setting that changes your flow. As the figure shows, the configuration process is not linear. You can take actions that skip some steps or revert to a previous step. However, if you perform an action that will disrupt the current configuration process and cause you to lose current configuration data, you will be prompted to confirm the action.

Fig. 7.2
Questionnaire Screen Navigation

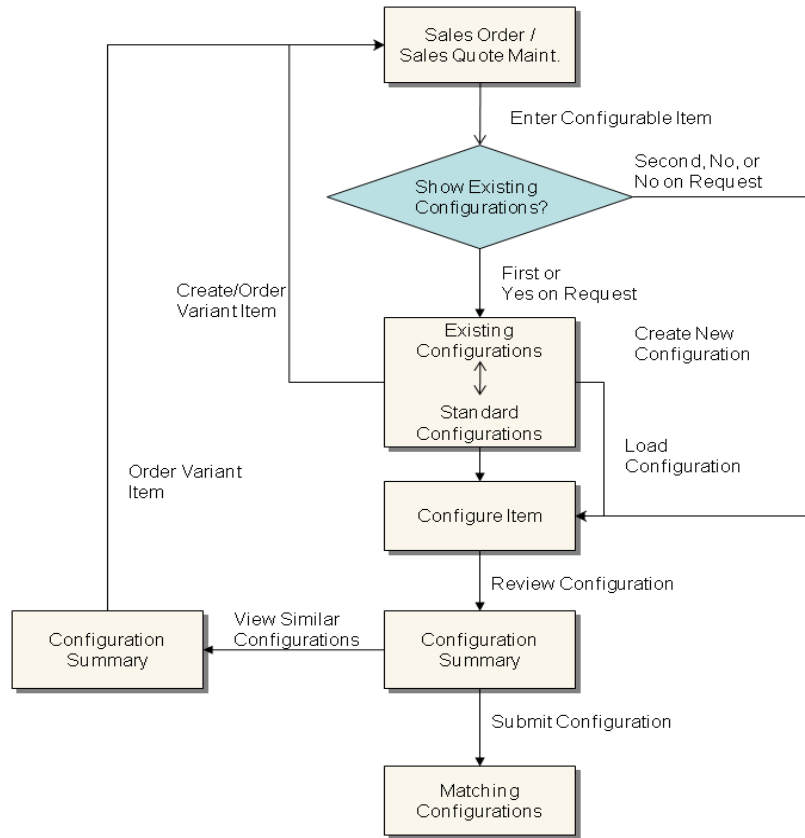

Exiting Questionnaire

You exit the Questionnaire module when you either complete or cancel the configuration process. When you have gone through all the configuration steps and successfully submitted your configuration, the Questionnaire window closes and a variant item number is returned to the Item Number field in the order line in Sales Order Maintenance or Sales Quote Maintenance. This could be an existing variant item number or a newly created variant item number, depending on the configuration you submitted.

You can cancel at any point in the configuration process by clicking the Cancel button in the Questionnaire screen. A confirmation window appears.

Fig. 7.3
Exit Confirmation

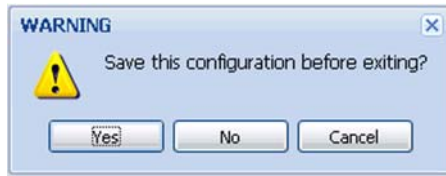

When you cancel the configuration process, the Questionnaire window closes and no item number is returned. You then either select a different item in the order line in Sales Order Maintenance or Sales Quote Maintenance or launch the Questionnaire window again if you continue with the original configurable item number.

Note Do not exit Questionnaire by clicking the Close Window button (X) in the upper right corner of the Questionnaire window or pressing Alt+F4. You are not prompted to confirm the exit this way and may lose your changes to the configuration.

Variant Item Configuration Workflow

The following diagram outlines the variant item configuration workflow.

Fig. 7.4
General Item Configuration Workflow

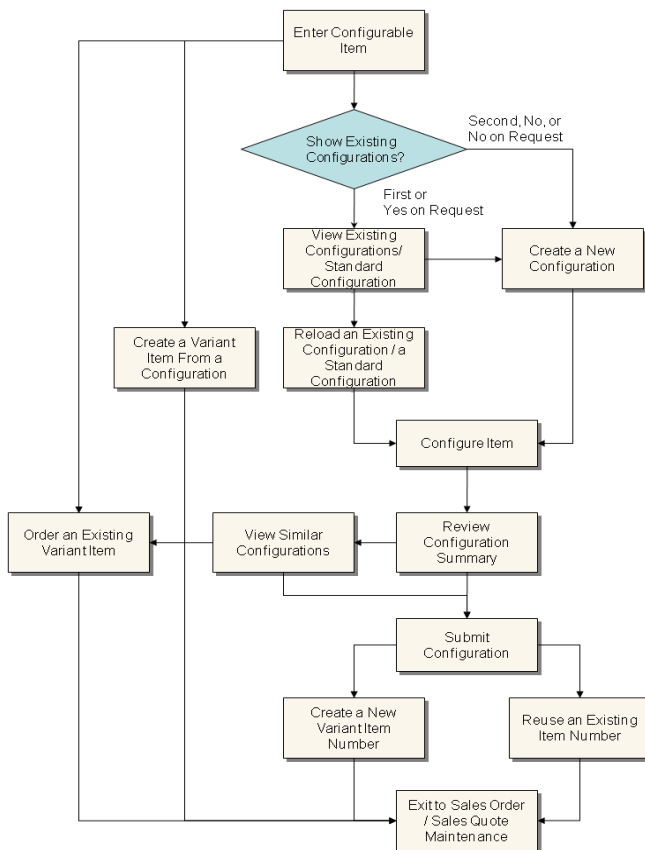

A typical configuration workflow is as follows:

- 1 View standard configurations in the Standard Configurations screen or existing configurations in the Existing Configurations screen.

Before you start configuring an item for a customer, you can browse through standard configurations in the Standard Configurations screen or existing configurations in the Existing Configurations screen; there might be existing variant items associated with the current configurable item and you can just use these configurations or modify them to get a similar configuration to meet your specific requirements.

If you find a variant item that exactly matches your requirements, you can directly submit it to add it to the sales order line and skip all the subsequent configuration steps.

If you find a configuration that exactly matches your requirements, but no variant item has been created from it, you can create a new variant item based on this configuration and add it to the sales order line.

If you find a configuration that partially matches your requirements, reload the configuration into the questionnaire and then customize the configuration in the Configure Item screen. After the customization, you can proceed to review and submit the configuration to create a new variant item from it.

If a saved configuration is unfinished, you can load it to complete the configuration.

Of course, if there is no configuration that you can reuse, you need to create a configuration from scratch.

- 2 Configure a variant item in the Configure Item screen.

Whether you reload an existing configuration or create one from scratch, you customize your configuration in the Configure Item screen. You do this by answering a list of questions that correspond to the current configurable item features. When you finish answering the questions, you have created a configuration and you then proceed to review and submit it.

- 3 Review and submit configuration in the Configuration Summary screen.

After you have completed the Questionnaire questions, review the complete configuration summary information to make sure that everything is correct.

If you find errors in your answers, you can always go back to the Configure Item screen to correct your answers. Unanswered questions and answers that conflict with variable rules will prevent successful submission of your configuration.

You can view similar configurations by filtering existing configurations using your configuration as a criteria. You can then choose to order a similar variant item, create a new variant item from a similar configuration, or continue with your own configuration.

Unless you set the Show Existing Configurations option to No in Configurable Item Maintenance, the system finds existing configurations that match the configuration based on configuration keys. You can choose either to create a new variant item using your configuration or associate an existing item number with your configuration.

Using Standard/Existing Configurations

Before you start configuring an item for a customer, you can browse through standard configurations in the Standard Configurations screen or existing configurations in the Existing Configurations screen; there might be existing variant items associated with the current configurable item and you can just use these configurations or modify them to get a similar configuration to meet your specific requirements.

Note Whether and how the Existing Configurations tab is displayed in the questionnaire is controlled by the Show Existing Configurations option in Configurable Item Maintenance. This section assumes that the Show Existing Configurations option is set to First. For details about this option, see “Maintaining Configurable Items” on page 47.

Fig. 7.5
Viewing Standard Configurations in Standard Configuration Screen

All standard configurations for Item 01040		
Configuration ID	00001091	00001041
Variant Item	01040-055	01040-051
Customer	ATEST01	
Status	F	F
Create date	12/11/11	12/07/11
User ID	CSS_demo	mfg
Description		
List Price (USD)	3,344.05	3,112.55
Net Price (USD)	3,344.05	3,112.55
Backup (Short)	Yes	No
Backup Type (Short)	Alkaline	N.A.
Printer	Yes	No
Keyboard Cover	Yes	No
Length	60	60
Display Type	Top Display	Front Display
Height	120	120
Width	60	160
Area	36,000	72,000
Qty - Large Steel	0	1
Qty - Small Steel	4	1
Color	Black	Black
Item Description	Industrial Ultrasound	Industrial Ultrasound
CPU	Standard	High
Frequency	500 KHZ	10 MHZ

Note Now that QAD CSS and QAD Configurator are integrated, there can be configurations created by CSS users. For example, in Figure 7.5, CSS_demo in the User ID field indicates that the configuration is created by a CSS user. The prefix CSS_, as in CSS_demo, can be modified in the `cssUserPrefix.i` file under the `ConfiguratorWebSpeedInstallDir/src/webconf` directory. The prefix modification will take effect after you compile the Configurator WebSpeed files.

Browsing Standard / Existing Configurations

For standard configurations in the Standard Configurations screen or existing configurations in the Existing Configurations screen, the key attributes and all item features are displayed for each configuration.

Configuration ID. Configuration ID uniquely identifies a configuration stored in the system.

Variant Item Number. Variant item number uniquely identifies a variant item created in the system. A configuration ID is associated with a variant item number only when a variant item has been created from the configuration.

Customer. Specifies which customer this configuration was created for.

Status. Specifies the status of the configuration.

O: The configuration has not been completed yet—that is, not all required questions in the Questionnaire have been answered. You can load and proceed with the configuration. Unfinished configurations cannot be used to create variant items.

F: The configuration has been completed. You can load the configuration to modify it or directly create a new variant item from it.

Note Standard configurations are completed configurations, so the status for standard configurations is always F.

List Price. Displays the configuration's list price as calculated by Configurator when the configuration was created. You can reprice it when you load the configuration to bring the configuration list price up-to-date.

Net Price. Displays the configuration's net price as calculated by Configurator when the configuration was created. You can reprice it when you load the configuration to bring the configuration's net price up-to-date.

Create Date. Shows when the configuration was created.

User ID. Shows which QAD Configurator user created this configuration.

Description. Provides a brief description of the configuration.

Item Features. All features of the current configurable item are listed along with their values.

By default, five configuration records are displayed on each page. You can use the Item Per Page value at the bottom of the screen. If the configuration display exceeds the screen size, use the horizontal scroll bar at the bottom of the grid to view all configuration records.

If there are multiple pages, use the navigation controls at the bottom of the screen to page through the records or jump to a specific page.

The existing configurations grid provides flexible ways to display configuration records and lets you easily compare configurations. You can change the position of a configuration record by dragging and dropping its configuration ID column header. This way, you can place configurations of interest side by side for easy feature comparison. You can also sort configuration attributes and features by clicking on the column header displaying the configuration ID.

Searching for Configurations

The Questionnaire .NET UI provides extensive, configurable search capabilities that let you create both simple and complex queries.

Fig. 7.6
Configurations Search Box

- 1 Initially, one search condition displays. Choose the attribute or feature that you want to search from the drop-down list.
- 2 Choose a search operator from the drop-down list. The search operators include the following:
 - equals
 - no equals
 - greater than
 - less than
 - is null
 - is not null
 - range
 - starts at
 - contains
- 3 If you choose the Range operator, enter a beginning value of the range in the first search box. Optionally, enter an ending value of the range in the second search box.
- 4 Click Search.
- 5 To refine your search further, click the plus (+) icon to add another search row. You can add as many rows as needed, each with different search values and operators. When you specify several criteria, note that multiple criteria for the same field are treated as a logical AND condition.
- 6 To remove a search criteria row, click on the delete (X) icon.

Ordering an Existing Variant Item

If you find an existing variant item that exactly matches your specific configuration requirements, you can directly order the variant by clicking the Submit icon next to the variant item number. This closes the Questionnaire window and returns the variant item number to the item number field in the Sales Order Maintenance or Sales Quote Maintenance order line.

Existing variant items are configuration records that have variant item numbers and are marked with the F status.

Run SO/SQ Line Rules for Ordering Existing Variant Items

SO/SQ Line rule is executed both when creating a new variant item and ordering an existing variant item. Selecting an existing variant item sets default values for the line fields.

The following list describes the cases when the SQ/SO Line rule is executed:

- When the user clicks the “Order” icon on existing configuration lists
- When the user clicks the “Order” icon on the similar configuration lists
- When the user clicks the “Order” icon on the save variant item pop-up window
- When the program finds a matching variant item and selects it automatically, due to the auto-selection clause setting

Check and Recreate Price List for Ordering Existing Variant Items

If you order an existing variant item from Configurator, the system first checks whether there are any valid price lists. If there are none, Configurator creates a new price list to make sure that the correct price is provided to the SO/SQ line.

You must set Create Price List in Configurable Item Maintenance to Yes to enable this function.

Creating a Variant Item

If there is a configuration that you can reuse but no variant item has been created from it (no variant item number is displayed in the variant item field), you can create a variant item from it and order the new variant item by clicking the Create Variant icon next to the Configuration ID. This closes the Questionnaire window and returns the newly created variant item number in the item number field to the Sales Order Maintenance or Sales Quote Maintenance order line.

Only completed configurations with a status of F can be used to create new variant items. Incomplete configurations with a status of O must be completed first before they can be used for item creation.

Reloading a Configuration

You can reload a configuration in the Standard Configurations screen or Existing Configurations screen, and modify it in the Questionnaire. To reload an existing configuration, click the Reload Configuration icon next the Configuration ID. This directs you to the Configure Item screen, which displays all the configuration questions and answers.

- If you reload a finished configuration with a status of F, a duplicate of the existing configuration will be created with a new configuration ID. All the questions and answers in the Questionnaire will be the same, but you will actually be working on a new copy of the original configuration.

Note Standard configurations are always finished configuration with a status of F.

- If you reload an incomplete configuration with a status of O, the original configuration with the same configuration ID will be loaded.

Creating a New Configuration

To create a new configuration from scratch, click the New Configuration button in the Existing Configurations screen to go to the Configure Item screen.

Configuring Item

Whether you reload a configuration or create one from scratch, you customize your configuration in the Configure Item screen. You do this by answering a list of questions that correspond to the current configurable item features.

Fig. 7.7
Configure Item Screen

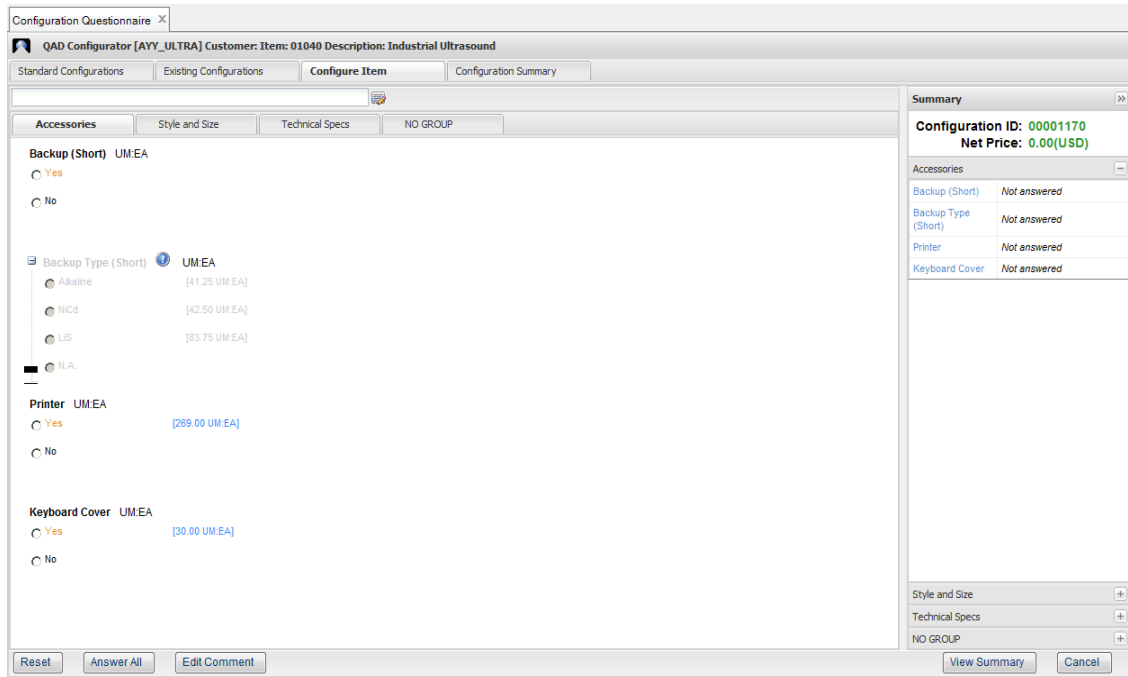

Answering Questions

In the Configure Item screen, questions are grouped under corresponding functional group tabs. You can switch among different functional group tabs to view and answer questions. If no functional group is defined, all questions are listed under a single tab.

By default, ten levels of foreground questions are displayed in the short question format. You can customize the questionnaire settings to display temporary and background questions as well, and show questions in the long question format. You can also specify how many dependency levels of questions to display in the questionnaire.

If you display multiple levels of questions, since higher level questions are dependencies of lower level questions, lower level questions will be disabled until prerequisite higher level questions have been answered.

Default answers are highlighted but are not automatically selected or entered for foreground questions.

If valid answers to a question must fall within a value range, the beginning and ending values of the range will be displayed next to the question. Use this as a reference to provide valid answers.

To reset questions, click the Reset button to revert all the questions to the unanswered state.

To automatically answer the questionnaire, click the Answer All button to answer all the questions using their default options.

Errors occur when you provide an invalid value for an answer or when your answer violates option dependency rules. When this happens, an alert icon appears next to the question and the message bar displays relevant error messages. You must fix all errors to successfully complete the questionnaire.

Reviewing Answer Summary

The hideable Summary panel lets you review at a glance all the answers you have provided so far in the process of answering questions.

At the top, the Summary panel displays the current configuration ID and item price information. Item price is updated each time you answer a question. You can customize the Questionnaire settings to specify which type of price information you want to see.

The summary panel includes a running summary of questions and answers you have supplied for each functional group. You can click a question in the panel to access it, making it easy to locate a question and navigate in the questionnaire.

Viewing Question Rules

If a question has rules, a question mark icon displays next to it. Move your cursor over it to view its rules.

Note The configuration questionnaire shown in QAD CSS does not display the question mark. Therefore, if question rules are needed to be shown, the question rules need to be in the question description.

Fig. 7.8
Question Help

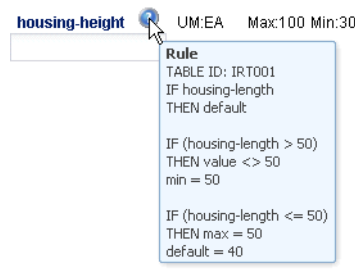

Editing Comments

To view or edit a comment for a configuration, click the Edit Comment button. In the Comment widow, edit the comment description or details. You can search for configurations in the Existing Configurations screen based on the comment description.

Fig. 7.9
Comment Window

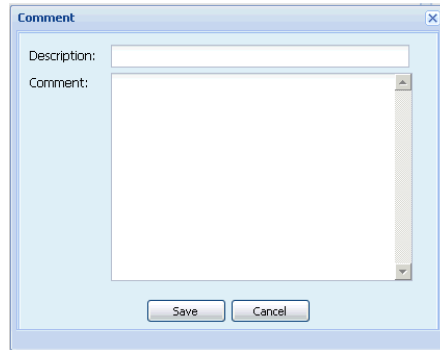

Customizing the Questionnaire

You can customize whether to display certain elements in the questionnaire and how they are displayed.

To customize the questionnaire, click the Customize icon next to the message bar in the Configure Item screen. A Customize screen displays. Change the settings and click OK to save your changes.

Note Display settings only apply to the Questionnaire window you are currently working in. Your customized settings are not saved when you exist Questionnaire.

Fig. 7.10
Customize Screen

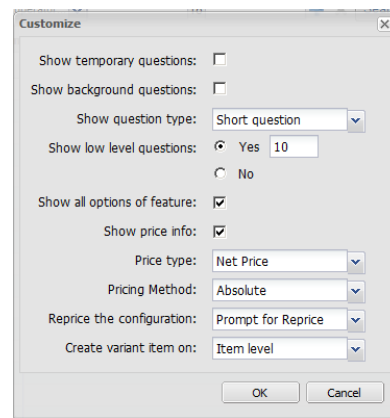

Show temporary questions. Specify whether to show temporary questions in the questionnaire. Temporary questions are automatically answered by QAD Configurator according to rules. The default is No.

Show background questions. Specify whether to show background questions in the questionnaire. Background questions are those that always have default answers and do not need to be answered by the user. However, users can manually answer background questions and override default answers. The default is No.

Show question type. Specify whether to display long questions and answers or short questions and answers in the questionnaire. Short questions and answers are displayed by default.

Show low level questions. Specify whether to show low level questions in the questionnaire. Question levels are determined by question dependencies. A lower level question is dependent on the answers to a higher level question and cannot be answered before the higher level question is answered.

- Yes: Low level questions will be displayed in the questionnaire. Specify the number of levels to display. The default is 10.
- No: Only the first level questions will be displayed.

Show all options of feature. Specify whether to show all feature options. If this setting is selected, the excluded options, which are not available to select, can be seen as dimmed. If this setting is not selected, you cannot see the excluded options. Select the setting if you want to facilitate diagnosing configuration errors. The default value of the option is inherited from the setting of the current configurable item in Configurable Item Maintenance.

Show price info. Specify whether to show price information for the item being configured. Price is not displayed by default.

Note If your transaction currency is different from the domain currency, the price will be converted from the domain currency and displayed in the transaction currency.

Price type. Choose the type of the price to be calculated for the item being configured.

Pricing method. Specify the method to use to calculate and display the price of the configuration.

Absolute: The item price is calculated by adding up the prices of all the components in the item based on configuration answers.

Relative: The item price is displayed as a price variance relative to the default item price.

Reprice the configuration. Specify whether to reprice the configuration when you load an existing one. A configuration's price is the cumulative sum of the prices of all its components. Since component prices may change over time, repricing a configuration recalculates the price based on the most current component prices.

When a configuration is repriced, existing price lists are updated. The system does not expire existing price lists and create new ones.

Prompt for reprice: When you load an existing configuration, you are prompted to reprice the configuration.

Always reprice: You are prompted when loading an existing configuration; the configuration price is always recalculated based on current component prices.

Don't reprice: The configuration price is not recalculated; the original price stored as part of the configuration is used.

Create variant item on. Specify whether or not you want to create variant items on the item level.

After you complete all the questions, click the View Summary button or the Configuration Summary tab to proceed to the next step in the item configuration process.

Reviewing and Submitting Configuration

The Configuration Summary screen lets you review the answers you have provided so far, save your configuration, and view similar configurations, and finally create and order a variant item based on your configuration.

Fig. 7.11
Configuration Summary Screen

Question Group	Question	Answer	Net Price
Accessories	Backup (Short)	No	
Accessories	Backup Type (Short)	N.A.	
Accessories	Printer	No	
Accessories	Keyboard Cover	No	
Style and Size	Length	60	
Style and Size	Display Type	Front Display	
Style and Size	Height	120	
Style and Size	Width	160	
Style and Size	Area	72,000	
Style and Size	Qty - Large Steel	1	
Style and Size	Qty - Small Steel	1	
Style and Size	Color	Black	
Technical Specs	Item Description	Industrial Ultrasound	
Technical Specs	CPU	High	1,730.00
Technical Specs	Frequency	10 MHZ	1,320.00
Technical Specs	Painted	Painted	
Technical Specs	Product Line	Finished Goods	
Technical Specs	Portable	Yes	2.55
Technical Specs	Country to be installed	N.A.	
Technical Specs	Power Converter	Standard	60.00
Technical Specs	battery-type	Alkaline	412.50

Summary	
Configuration ID:	00001041
List Price:	3,525.05 (USD)
Net Price:	3,525.05 (USD)
Discount:	0.00%
Description:	No Description
Comment:	No Comment

Reviewing Current Configuration

The configuration summary table displays question group (functional group), question (feature), answer (selected feature option), and net price of components calculated based on selected feature options for each question. The hideable Summary panel on the right displays general information about the configurable item you are configuring.

All the questions or features of the configurable item you are configuring are displayed in the configuration grid. Unanswered questions show Select an Option in the Answer column.

When you review your answers, you can always click the Back button or the Configure Item tab to return to the questionnaire to change your answers.

To jump to a specific question in the questionnaire, click the answer in the configuration grid.

Viewing Similar Configurations

When you have completed or partially completed the questionnaire, you can view existing configurations that are similar to the configuration you have created so far. The system searches for similar configurations by filtering existing records using your answers as search criteria. If no

answer is provided to a question, the corresponding feature is not used to compare configurations. If none of the questions are answered, all existing configurations associated with the current configurable item are considered similar configurations.

To use this feature, click the View Similar Configurations button in the Configuration Summary screen. A Similar Configurations window displays.

Fig. 7.12
Similar Configurations Window

The screenshot shows a window titled "View similar configuration" with a "Sun" button in the top right. The main content is a table titled "All existing configurations for Item 10-20000-V". The table has 5 columns representing different configurations. The first column is the current configuration, and the other four are similar ones. The table includes fields for Configuration ID, Variant Item, Customer, Status, List Price (USD), Net Price (USD), Create date, User ID, Description, add-base-price, backup, backup-type, and salesprice. At the bottom, there is a navigation bar with "Page: 1 of 14", "Displaying 1 to 5 of 68", and "Items per Page: 5". A "Cancel" button is located at the bottom right.

Configuration ID	00004370	00004341	00004339	00004329	00004328
Variant Item		10-20000-V-023...	10-20000-V-022...	10-20000-V-021...	10-20000-V-...
Customer			4000	00010000	00010000
Status	O	F	F	F	F
List Price (USD)	500,000.00	500,790.00	500,790.00	500,790.00	500,790.00
Net Price (USD)	500,000.00	500,510.00	500,510.00	500,790.00	500,790.00
Create date	03/03/09	03/03/09	03/03/09	03/03/09	03/03/09
User ID		mfg	mfg	mfg	mfg
Description					
add-base-price	yes	Yes	Yes	Yes	Yes
backup		Yes	Yes	Yes	Yes
backup-type		atomic batt.	atomic batt.	atomic batt.	atomic batt.
salesprice		300.00			750.00

Your current configuration is displayed on the left of the screen with all the configurable item questions and the answers you have provided. On the right of the screen, all similar configurations with identical feature options to the answers you have answered are displayed in a comparison table.

Submitting Configuration

This is the final step in the item configuration process. After you have gone through all the questions in the questionnaire and created a configuration based on your answers, you submit the configuration. The system saves it as a new variant item or a matching one and returns the variant item to the order line in Sales Order Maintenance or Sales Quote Maintenance.

To submit your completed configuration, click the Save Configuration button at the bottom of the Configuration Summary screen.

If the configuration you are submitting was loaded from an incomplete configuration in the previous step, the system prompts you to update the original configuration or to create a new one. If you choose to update the original configuration, it is overwritten by your current configuration. If you choose to create a new configuration, a new configuration record is created with a new configuration ID.

The Matching Configurations window displays when the current configuration is submitted.

Note If Auto Select is set to Yes in Configurable Item Maintenance, the Matching Configurations window does not display and the Questionnaire window closes. Different combinations of configuration-selection, auto-select, and configuration-retention values determine how the system behaves when a configuration is submitted and how variant items are created.

Fig. 7.13
Matching Configurations

All existing configurations for Item 10-20001				
Configuration ID	00000780	00000780	00000777	00000774
Variant Item	<input type="checkbox"/>	10-20001-BDLS	10-20001-BDGS	10-20001-BDES
Customer	4000	4000	4000	4000
Status	F	F	F	F
List Price (USD)	800.00	800.00	800.00	800.00
Net Price (USD)	800.00	800.00	800.00	800.00
Create date		03/19/08	03/19/08	03/19/08
User ID		mfg	mfg	QAD
usage	industrial	industrial	industrial	industrial
Coolant	medic grade	medic grade	medic grade	medic grade
region	UK	UK	UK	UK
backup	yes	yes	yes	yes
backup-type	alkaline batt.	alkaline batt.	alkaline batt.	alkaline batt.

Page 1 of 1 | Displaying 1 to 3 of 3 | Items per Page 5

Cancel

Your current configuration is displayed on the left of the screen with all the configurable item questions and the answers you have provided. On the right of the screen, the system displays all matching configurations with identical configuration keys. Compare matching configurations with your current one to make sure you do not create redundant variant items with identical configurations.

Depending on displayed data, you can perform one of the following actions in the Matching Configurations screen:

- Create a new variant item from the current configuration.

Click the C (Create variant item) icon in the Variant Item field of the current configuration to create a new variant item. After a brief display of the variant item creation process bar, the Questionnaire window closes and the newly created variant item number is returned to the Item Number field in Sales Order Maintenance or Sales Quote Maintenance.

Note If you set up variant planning item rules for the configurable item and if changes to the configuration lead to changes to the variant planning item, the new variant item will be attached to the new planning item as a component and consume its forecast.

- Assign an existing variant item to the current configuration.

Click the S (Select the variant item) icon next to a matching variant item number to save the current configuration and associate it with that variant item number. The Questionnaire window closes and the newly assigned variant number is returned to the Item Number field in Sales Order Maintenance or Sales Quote Maintenance.

Note If you set up variant planning item rules for the configurable item and if changes to the configuration lead to changes to the variant planning item, the re-assigned variant item will still be attached to the original planning item and consume its forecast. Once attached to a planning item, an existing variant item is always associated with the planning item unless you perform a configuration rebuild.

Administration

Performing Element Roll-Up 138

Explains how to use Element Roll-Up.

Maintaining Component Effective Dates 139

Explains how to use Component Effectivity Date Maintenance.

Maintaining Routing Effective Dates 139

Explains how to use Routing Effectivity Date Maintenance.

Importing and Exporting Data 140

Discusses creating data packages and loading QAD EA and QAD Configurator data.

Deleting and Archiving Configurations 143

Explains how to use Configuration Delete/Archive.

Changing Configurable Item Numbers 144

Explains how to use Configurable Item Number Change.

Maintaining Configurations Manually 144

Explains how to use Manual Configuration Maintenance.

Rebuilding Configurations 146

Explains how to use Configuration Rebuild.

Running Batch Compiler 152

Explains how to use Batch Compiler.

Maintaining Standard Configurations 153

Explains how to use Standard Configuration Maintenance.

Using Configurator Metrics 154

Lists the metrics that allow the user to gauge how effectively the Configurator is being used.

Configurator Best Practices 154

Lists some business scenarios and solutions.

Administration Functions Overview

QAD Configurator provides you with a host of system administration tools that you can use to effectively maintain the system and keep it running with high performance and stability on a day-to-day basis.

Fig. 8.1
Configurator Administration Functions

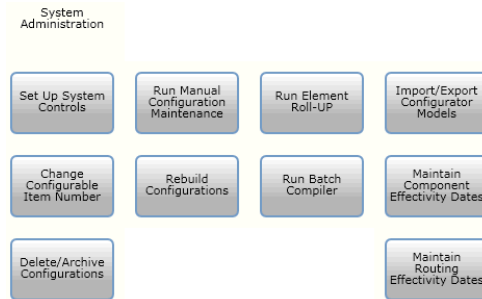

Performing Element Roll-Up

Use Element Roll-Up to roll up non-cost-related data elements. This function can be either automatically performed during variant item generation or manually executed from the menu.

Fig. 8.2
Element Roll-Up

The screenshot shows the 'Element Roll-Up' dialog box. It features a title bar with the text 'Element Roll-Up' and a close button. Below the title bar is a menu bar with the following items: 'Action', 'Print', 'Print Preview', 'Delete', 'Group', 'VIZ', and a help icon. The main content area contains four rows of input fields, each preceded by a radio button:

- Variant Item: [input field] To: [input field]
- Variant Item file: [input field]
- Generic Item: [input field] To: [input field]
- Generic Item file: [input field]

Variant Item. Specify a variant item or a range of variant items to roll up.

Variant Item File. Specify a previously created ASCII file that contains the item numbers of all the configurable items you want to roll up.

Configurable Item. Specify a configurable item or a range of configurable items to roll up.

Configurable Item File. Specify a previously created ASCII file that contains the item numbers of all the configurable items you want to roll up.

Click OK to start the element roll-up process and generate an element roll-up report, which you can view, save, and print.

Maintaining Component Effective Dates

Use Component Effectivity Date Maintenance to update component effective dates in the QAD EA production database when engineering changes occur. This functionality is required when components have been added to the QAD EA production database with start or end effective dates that prevent the selection of these components.

Fig. 8.3
Component Effectivity Date Maintenance

Rule	Component	Reference	Start Date	End Date	Source Start	Dest Start	New Start	New End	Qty Per
N	22-100								1.0
N	22-110								1.0
N	22-120								1.0
N	22-130								1.0
N	30-100								10.0
N	30-1000								10.0
N	30-10000								10.0
N	32-100V								1.0
N	44-100V								1.0
N	55-100								1.0
N	66-100								1.0
N	66-110								1.0
N	66-120								1.0
Y	77-100								1.0
N	77-110								1.0
N	77-120								1.0

The function displays all the components of the selected configurable item along with their reference, start, and end effective dates in the source database.

To update the effective dates of a component:

Specify the destination start date, new start date and new end date by clicking the Down arrow next to these column heads.

Click the Save button to save the changes. The Rule column changes to Y to indicate that there is an active rule for this component.

To remove a rule, select the component and click Delete Rule.

Maintaining Routing Effective Dates

Use Routing Effectivity Date Maintenance to update operation effective dates in the production database when engineering changes occur. This functionality is required when operations have been added to the QAD EA production database with start or end effective dates that prevent the selection of these operations.

Fig. 8.4
Routing Effectivity Date Maintenance

Rule	Operation	Start Date	End Date	Source Start	Dest Start	New Start	New End
Y	10						
N	20						

The function displays all the operations of the selected configurable item along with their start, and end effective dates in the source database.

To update the effective dates of an operation:

Specify the destination start date, new start date and new end date by clicking the Down arrow next to these column heads.

Click the Save button to save the changes. The Rule column changes to Y to indicate that there is an active rule for this component.

To remove a rule, select the operation and click Delete Rule.

Importing and Exporting Data

Use Model Import/Export to create data packages and load QAD EA and QAD Configurator data.

Creating Data Package

Select Export to create a data package file that contains all QAD EA and QAD Configurator records associated with the selected configurable item.

Fig. 8.5
Model Export

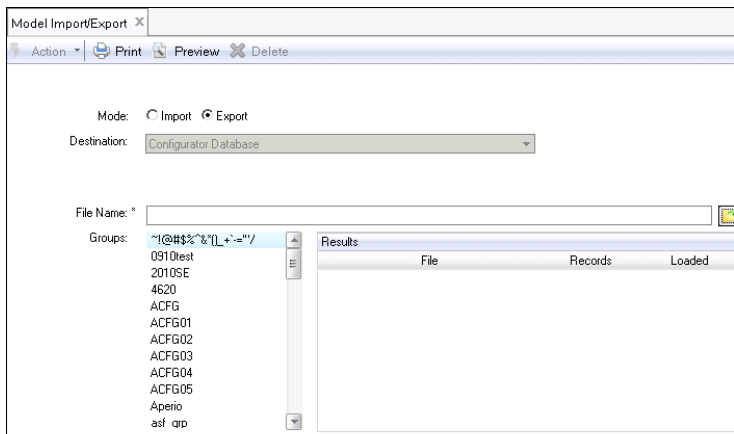

File Name. Specify the name and location of the package (.pkg) file to be created. You can select an existing file using the Browse button and the existing file will be overwritten.

Groups. Select the groups you want to include in the package.

The package includes the tables listed in the following two tables.

Table 8.1
QAD Configurator Tables Associated with a Configurable Item

Table	Description
agd_det	Generic Product Structure Assignment Rule table
agpd_det	Part Master table
agqd_det	Holds the rules for the fields to be set in Sales Quote Detail
agrd_det	Generic Routing Assignment Rule table

Table	Description
agr_mstr	Routing Master table
agsd_det	Holds all the rules for fields to be set in the sod_det table
ag_mstr	Generic Product Structure Master table
ans_mstr	Structure of (questionnaire) features per configurable item
cee_mstr	External Entity Master table
een_mstr	Element Entity Master table
effc_mstr	Component Effectivity Update Master table
effr_mstr	Routing Operation Effectivity Update Master table
eru_mstr	Element Roll-Up Master table
fea_mstr	Feature Master table
fed_det	Feature Detail table
fg_mstr	Functional Group Master table
fod_det	Rule Detail table
for_mstr	Rule Master table
fpg_mstr	Xref Rule table for part or rule groups
ftb_mstr	Rule/Rule table Master table
grp_mstr	Master Group table
pcpt_mstr	Configurable Item Master table
prg_mstr	Item – Rule Group Master table
prid_det	Option Priority/Default Detail table
pri_mstr	Option Priority/Default Master File
ptn_mstr	Part Number Master table
qst_mstr	Question Type Master table
rea_mstr	Product Configuration Rule table
rg_mstr	Rule Group Master table
tb_det	Detail Rule table
tb_find	Search Logic table for Rule tables
tb_mstr	Master table for Rule tables
tb_pack	Cell expressions for Rule tables
tb_xref	Expression to column Xref for Rule tables
tpt_mstr	Xref table for Item and Rule table
vad_det	Variable Detail table (Options)
var_mstr	Variable Master table

Table 8.2
QAD EA Tables Associated with a Configurable Item

Table	Description
pt_mstr	Item Master Table
ps_mstr	Product Structure Master Table
ro_det	Routing Detail Table

Loading QAD EA and QAD Configuration Data

Select Import to load data from data package files into the QAD EA and QAD Configurator databases respectively.

Fig. 8.6
Model Import

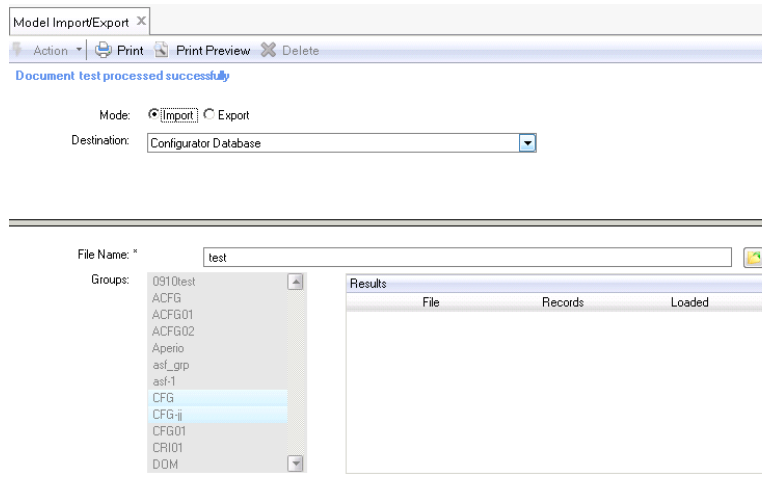

File Name. Specify the name and location of the package (.pkg) file to load data from.

Destination. Select a database to load the data to. Select the ERP database first when importing a model.

The load process first deletes all associated item, product structure, and routing records in the database, and then loads data from the package file to ensure exact data duplication.

Prior to deleting associated records and loading data into the QAD Configurator database, the load process also performs these steps:

- 1 Configurable item locking. Configurable items in question will first be locked to ensure that no one can start a questionnaire while the load is in process. If the user tries to start a questionnaire in a group that is being loaded, a message displays showing that the configurable item is currently unavailable.
- 2 QAD EA data comparison. The QAD EA data is compared against the data in the data package. Item masters, product structures, and routings are all checked to ensure data consistency. If any differences such as missing item masters, components, or operations are detected, an error report is generated and the process stops. Any discrepancies must be corrected before the load is allowed to continue.

Active User Check. Once the data comparison has passed, the system determines if there are any users currently processing questionnaires within the groups being loaded. If active users are found, the Active User Manager displays showing which users are currently active and prompting to cancel the load or wait until no user is active. If you choose to wait, when all users have completed their questionnaires, the load process will automatically continue.

Comment Handling. The comment information of the following programs is included in the package during Model Import/Export transactions:

- Master Group Maintenance

- Configurable Item Maintenance
- Variable Maintenance
- Variable Option Maintenance
- Feature Maintenance
- Feature Option Maintenance
- Rule Group Maintenance

Deleting and Archiving Configurations

Use Configuration Delete/Archive to archive and/or delete existing configurations.

Each time you complete the questions in the questionnaire and click OK, QAD Configurator generates a new configuration in the database, containing all the answers to the questions for the configurable item. The configuration is created even if no variant is generated. As a consequence, the configuration table in the QAD Configurator database can grow rapidly.

You can use Configuration Delete/Archive to archive one or more configurations to a file for later use, or permanently delete configurations from the set of configurations available in QAD Configurator.

The variant product structure generator in the questionnaire uses configurations to create variant items. After you delete a configuration, this configuration is no longer available for creating a variant or for selection by means of the unique configuration key.

Fig. 8.7
Configuration Delete/Archive

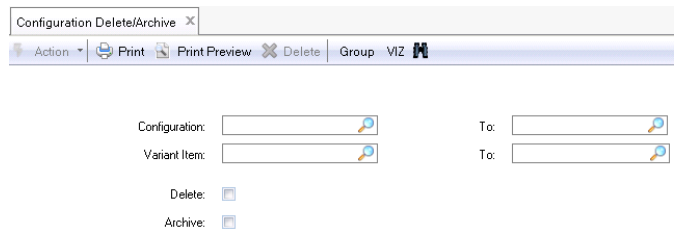

There are two methods you can use to specify the configurations you want to delete or transfer:

- Enter the configuration IDs of the particular configurations to be transferred or deleted.
- Specify the variant numbers that correspond with the particular configurations to be transferred or deleted.

If you enter one or more configuration IDs and one or more variant numbers, QAD Configurator will only archive or delete the configurations in the specified range for which the associated variant number is entered as well. That is, the configuration must be specified by both methods to be included in the archiving process.

Warning If you do not enter any configuration IDs or variant numbers, QAD Configurator will archive and/or delete all the available configurations in the group.

Changing Configurable Item Numbers

Use Configurable Item Number Change to manually update configurable item numbers in Configurator to be in sync with changes in QAD EA.

Note In QAD 2008.1 Enterprise and later, configurable items cannot have item replacement records and cannot be memo items.

Fig. 8.8
Configurable Item Number Change

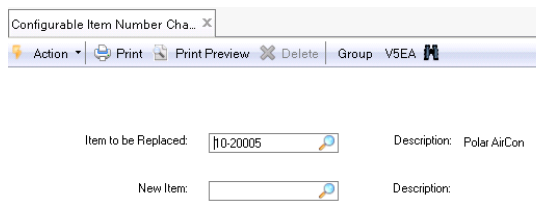

Maintaining Configurations Manually

Use Manual Configuration Maintenance to manually enter and maintain configurations.

A configuration consists of answers to all the questions relating to the configurable item.

QAD Configurator uses configurations in two ways:

- For creating a variant from the configurable item
- For selecting already existing variants with the same configuration description

Selecting already existing variants reduces the number of variant items that are created in the QAD EA item, product structure, and routing tables.

When you run the questionnaire and answer the questions with exactly the same answers as in a previous configuration, QAD Configurator will not create a new variant, but offer to use the existing configuration and thus limit the number of variants being created. This can significantly reduce the effort and the time involved in creating the variant product structure.

It is possible that there can be items in the QAD EA item and product structure tables that are valid variants, but that were not created using the QAD Configurator questionnaire and variant creator. These variants do not have a configuration description—that is, a configuration—in QAD Configurator and can never be selected as an existing variant. Using Manual Configuration Maintenance, you can create this configuration description afterwards and link it to the item in QAD EA.

Note The variant that is linked to the manually created configuration must be an item in QAD EA but cannot be a configurable item in QAD Configurator, because a configurable item can never be a variant of another configurable item.

Fig. 8.9
Manual Configuration Maintenance

Manual Configuration Maintenance

Action: [Print] [Print Preview] [Delete] Group: VIZ01 Configurable Item: 10-20000-V

Variant Item: 2-BB Description: Orange Bean Bag Purchase/Manufacture: L

Configuration: 00002293 Description: [] Comment

Status: F Date: Time:

Only Display Configuration Key Features

No Group Engine

paint-housing
 Yes
 No

test-fill
 Other []

housing-height
 [50] Max: 100 Min: 30 UM:EA

backup-type
 alk-aline batt.
 atomic batt.
 thermionuclear b
 n.a.

housing-length
 [60] Max: 100 Min: 30 UM:EA

pump
 low capacity
 medium capacity
 high capacity

Summary

No Group	
paint-housing	Yes
test-fill	
housing-height	50
backup-type	alk-aline batt.
housing-length	60
pump	medium capacity
region	UK
usage	domestic
sales-price	300
add-base-price	Yes

The variant field shows the variant item number for the manually maintained configuration that has been most recently accessed. The configuration ID, status, date, and time are shown in the frame below this field, and the details of the questionnaire answers that make up the configuration are shown in the feature/option list window.

To select another configuration to maintain, you can either use the navigation buttons in the button area, or you can click the Browse button to the right of the Variant field. The system displays a screen where you can select the required variant item, using filter fields in the top part of the screen to narrow the search.

When you have selected a manually maintained configuration, you can modify it by changing the answers to the questionnaire questions in much the same way as when using the questionnaire. If you no longer require the configuration, you can delete it by clicking the Delete button. The system displays a message prompting you to confirm the deletion.

For variant items created from questionnaire configurations, you can browse the configuration, modify descriptions, and add comments.

Fig. 8.10
For Variant Item Created from Questionnaire Configuration

Manual Configuration Mainten... x

Action Print Preview Delete Group AYY_ULTRA Configurable Item 01040

Variant Item: 01040-051 Description: Industrial Ultrasound Fro... P/M Code: M

Configuration: 00001041 Description: Comment

Status: F Date: Time:

Only Display Configuration Key Features

No Group Accessories Style and Size Technical Specs Summary

Ebattery-type

10

6

4

100

No Group

battery-type

Accessories

Style and Size

Technical Specs

Cancel Save New

Rebuilding Configurations

Use this function to update one or more existing configurations and variant items which are repeatedly ordered and need adjustments for one of the following reasons:

- Changes to the configuration details; for example, a new feature has been added or an option has changed
- Pricing changes, including changes in the Sales Configuration pricing rules
- Engineering changes to item data, product structure or routing, including changes in the Product Configuration rules

Note The Configuration Rebuild function does not perform cost roll-up.

Fig. 8.11
Configuration Rebuild

Configuration Rebuild x

Action Print Preview Delete Group ACFG04

Configurable Item 10-20000 Description Arctic Cooling System

Configurations to Rebuild:

Configuration	Variant Item	Customer	Status	Date Created	User ID	Description
00006202	10-20000/004	4000	F	11/16/2009	mfg	
00006201	10-20000/003	4000	F	11/16/2009	mfg	
00006200	10-20000/002	4000	F	11/16/2009	mfg	
00006199	10-20000/001	4000	F	11/16/2009	mfg	
00005691	10-20000/004	4000	F	08/03/2009	mfg	
00005686	10-20000/003	4000	F	08/03/2009	mfg	
00005683	10-20000/002	4000	F	07/27/2009	mfg	New Variant - Cooling System
00005680	10-20000/001	4000	F	07/27/2009	mfn	

Rebuild Options:

Feature Options

Pricing Effective Date: 10/10/2011

Product Structure/Routing Delete Expire

Show Detail Batch Job Size: 100

Cancel Rebuild

- 1 Select a configurable item. If the configurable item has not been analyzed yet, the system will prompt you to analyze it first.
- 2 A Configuration Browse window is displayed. Use the search box to filter records and look up the configurations you want to modify. Click OK to select all the configurations displayed in the browse.
- 3 Selected configurations are displayed in the Configurations to Rebuild list. You can click the Change Configurations icon to bring up the browse window to change your selections. For information on using the Configuration Browse, see “Using Browsers and Browse Collections” on page 35.
- 4 To make batch changes to features in all the selected configurations, select Feature Options. In the expanded box, specify changes to be applied to features of the selected configurations across the board during the rebuild process.

Important Use caution if you try to update features that are a part of the configuration key. This may lead to multiple variants associated with the same configuration key.

- a Under the Add/Update tab, specify changes to apply to the configurations by selecting features of the configurable item and assigning values to them. To assign a value to a feature, click the Browse icon to bring up a pop-up window that lets you designate values in either the basic format or the advanced format.
 - In the basic format, for features with defined options, select an option from the option list and click OK to assign the value to the feature; for features that allow fill-ins, including those associated with browse codes, you can add a new feature option or browse code to the option list and then select it as the new value for the feature. The system validates the new value during the rebuild process and displays an invalid option error when invalid values or undefined browse codes are found.

Fig. 8.12
Rebuild Feature Options

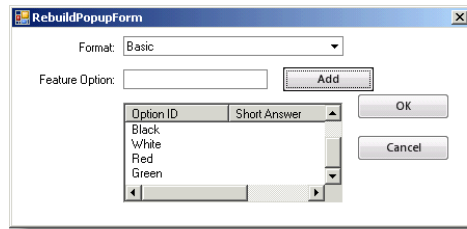

- In the advanced format, you can directly type feature values.
- b Under the Delete tab, specify variables to delete from the configurations. You can only delete variables that are no longer defined as features attached to configurable items.
- 5 If you want to reprice the configurations, select the Pricing check box. When this option is selected, both the list price and net price of the configurations, as well as related price lists, will be updated.

Note In the Effective Date drop-down list, you can select or manually enter a date for the updated price lists to take effect. The effective date is no earlier than the current date.
 - 6 If you want to update the product structures and routings of the variant items, select the Product Structure/Routing check box; then specify whether you want to obsolete or delete the old product structures and routings.
 - Delete: Old product structure and routing records are removed from the system. New records are created without date information.
 - Expire and Effective Date: Old product structure and routing records are marked as expired but are still retained in the system. You can manually enter the effective date for the new records; the End Date for old records is one day before the Effective Date for the new records. By default, the Effective Date is Today.

Note When expiring old product structure/routing records and creating new ones, the system keeps the records effective in the future intact.
 - 7 If you selected the Pricing and Product Structure/Routing options, you can select Show Detail to display detailed change information in the rebuild report.
 - 8 Click Rebuild. The system displays the number of configurations and variant items to rebuild and tells you that the rebuild process may take a long time. Click OK to start the rebuild process.

Note The rebuild process may take a long time depending on the number of configurations and variants to rebuild and the complexity of the configurations.
 - 9 Depending on your selected rebuild options, the system performs a number of batch updates to the configurations and variants including changing feature values, repricing configurations, and re-creating product structures and routings.

Note Currently, the system does not create new variants during configuration rebuild even if new variant item numbers should be generated from the changes. In such cases, the system displays a warning message informing you that the configuration changes warrant new variant item numbers. You can manually assign new numbers to affected variant items in Item Number Change (1.4.13).

- 10 When the rebuild process is complete, the system displays a rebuild report that summarizes all the updates made to the configurations and variants, including changes to features, product structures, routings, and price information, if available. You can print and save the report.

Fig. 8.13
Rebuild Report

Configuration ID	Item	Feature	Old Option	New Option	Comment
00000583	PT100-018	Site2	2	3	Option Updated
00000581	PT100-017	Site2	2	3	Option Updated
00000579	PT100-016	Site2	2	3	Option Updated
00000576	PT100-015	Site2	2	3	Option Updated
00000574	PT100-014	Site2	2	3	Option Updated
00000572	PT100-013	Site2	2	3	Option Updated
00000570	PT100-012	Site2	2	3	Option Updated
00000567	PT100-011	Site2	2	3	Option Updated
00000565	PT100-010	Site2	2	3	Option Updated
00000563	PT100-009	Site2	2	3	Option Updated
00000561	PT100-008	Site2	2	3	Option Updated
00000559	PT100-007	Site2	2	3	Option Updated
00000557	PT100-006	Site2	2	3	Option Updated
00000555	PT100-005	Site2	2	3	Option Updated
00000551	PT100-004	Site2	2	3	Option Updated
00000549	PT100-003	Site2	2	3	Option Updated
00000547	PT100-002	Site2	2	3	Option Updated
00000545	PT100-001	Site2	2	3	Option Updated

Configuration ID	Date	Item	Old List Price	New List Price	Old Net Price	New Net Price
Configuration ID	Date	Item/Routing	Component/Operation	Quantity	Comment	

The system runs the following product configuration rules when rebuilding a configuration:

- Variant item data rule
- Variant product structure rule
- Variant routing rule

Currently, the system does not process sales configuration rules during configuration rebuilds.

Note The rebuild process does not update product structures and routings for kit type configurable items—either physical kit or phantom kit.

If errors occur during the rebuild process, the system displays error messages that show affected variant item numbers and invalid options.

If the configuration rebuild process causes the planning item of its associated variant items to be changed, the system removes the association between the variant items and the old planning item and associates them with the new one. The changes are displayed in the result report.

Rebuild for Multi-level Configurations

A multi-level configurable product structure enables the modularization of product structures. Rather than one huge BOM that lists all possible components of a configured variant item, the product structure is divided into sub-assemblies that are configurable themselves and may have their own routings.

For example, as shown in Figure 8.14, C1 is a configurable item of the SO Type BOM. C2 is a component of C1 while C2 is also a configurable item itself.

Fig. 8.14
Multi-level Configurations

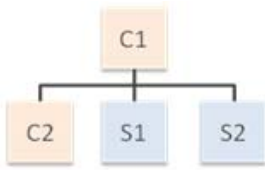

Here are some scenarios where multi-level configurations are used, including information about how the Configuration Rebuild performs.

Scenario 1: Configurable Sub-assembly

In this scenario, a configured subassembly is selected or created, depending on whether there exists a matching configured variant item.

Fig. 8.15
Configurable Sub-assembly

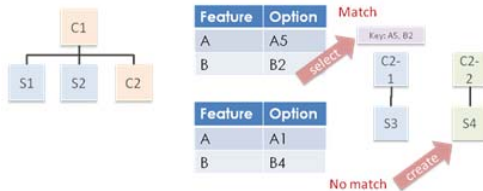

Item C2, a configurable sub-assembly, has a configurable product structure.

- If there is a configuration key for C2, either an existing variant is selected or a new variant is created. As shown in Figure 8.15, C2-1 is selected or C2-2 is created.
 - In Configurable Item Maintenance, set Configuration Selection to First Matching or Last Matching, if you want the system to select an existing variant.
 - In Configurable Item Maintenance, set Configuration Selection to Just Created, if you want the system to create a new variant.
- If there is no configuration key defined for C2, a new C2 variant, C2-2, is created.

In rebuilding the configuration for C1, the top-level configurable item, the system searches for a matching configuration for C2 according to the configuration key.

- If there is a match, the system uses the variant item, attaching it to the product structure of C1.
- If there is no match, the system deletes the entire variant product structure and rebuilds the multi-level structure according to the updated configuration and current rule set.

Note In rebuilding C1, when a matching configuration is found for C2, the system does not run product configuration rules. If there are any rule changes or feature value changes that could cause item data changes, lower-level configurations need to built first.

Scenario 2: Pre-configured Sub-assembly

In this scenario, all C2 sub-assemblies have been pre-configured and each has a configuration attached to it. The pre-configuration can be the result of the Configurator variant item creation process, or can come from Manual Configuration Maintenance, where you manually attach configurations to standard items after item creation. For more information about manually maintaining configurations, see “Maintaining Configurations Manually” on page 144.

Fig. 8.16
Pre-configured Sub-assembly

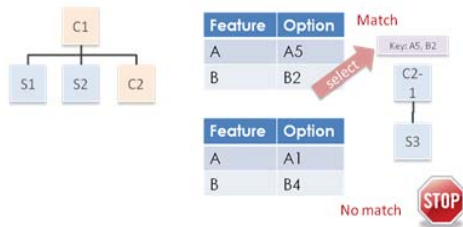

The system compares the relevant features of the new configuration with the configuration key defined for C2:

- If there is a match, C2 sub-assembly is selected.
- If there is no match, the system terminates the creation of C1 and reports an error.

In this scenario, the configurable item C2 does not have a configurable product structure since there is no new configured variant item created. C2 serves as a placeholder.

In rebuilding the configuration for C1, the top-level configurable item, the system searches for a matching configuration for C2 according to the configuration key.

- If there is a match, the system uses the variant item, attaching it to the product structure of C1.
- If there is no match, the system reports an error in the rebuild report.

Note In rebuilding C1, when a matching configuration is found for C2, the system does not run the Variant Item Data Rule. If there are any rule changes or feature value changes that could cause item data changes, lower-level configurations need to be built first.

Scenario 3: Item Number Selection

In this scenario, C2 has a huge number of variations and the possible component items might have very dynamic lifecycles. Additionally, the possible component items are standard items not created by the Configurator.

Fig. 8.17
Item Number Selection



Without a configuration key, the actual item wanted is selected explicitly by its item number. Use Variant Item Number Rule Maintenance to set the variant item number as the number of an existing standard item based on a single feature. Typically, an option list or item browse in the Questionnaire is used to manually select the wanted standard item and assign the item number to the feature in the variant item number rule.

In this scenario, C2 does not have a configurable product structure since there is no new configured variant item created. C2 serves as a placeholder.

In rebuilding the configuration for C1, the top-level configurable item, the system searches for a matching configuration for C2 according to the variant item number rule.

- If there is a match, the system uses the variant item, attaching it to the product structure of C1.
- If there is no match, the system reports an error in the rebuild report.

Note In rebuilding C1, when a matching configuration is found for C2, the system does not run the Variant Item Data Rule. If there are any rule changes or feature value changes that could cause item data changes, lower-level configurations need to be built first.

In Scenario 2 and Scenario 3, C2 serves as a placeholder. A configurable item placeholder can appear multiple times in the product structure, if each placeholder just gets the same item. But the system does not support the situation where a placeholder configurable item appears multiple times in the product structure while each placeholder has a different item. The reason is that for a placeholder configurable item, there is only one variant item number rule and one configuration key. If you want different configurable items in the product structure, just define different configurable items with configuration keys and variant item number rules.

Running Batch Compiler

Use Batch Compiler to compile the Progress source code for selection and assignment rules for one or more selected configurable items (including planning items). Recompiling the code after significant changes have been made—for example, after re-creation of the database—can save considerable time in subsequent Variant Creation processes.

Fig. 8.18
Batch Compiler

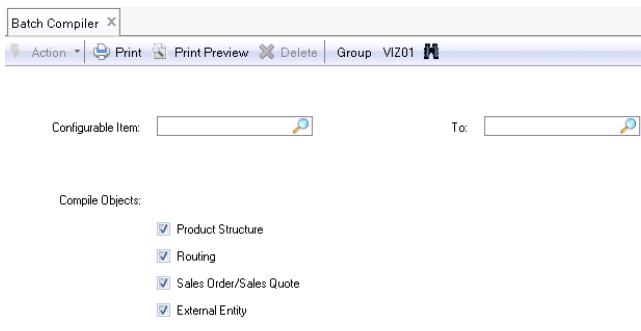

Maintaining Standard Configurations

You can use Standard Configuration Maint (50.4.10) to get standard configurations that are shown in the Standard Configurations screen of the Questionnaire. To set an existing configuration to a standard configuration, just select the check box above the configuration ID of the existing configuration.

Fig. 8.19
Standard Configuration Maintenance

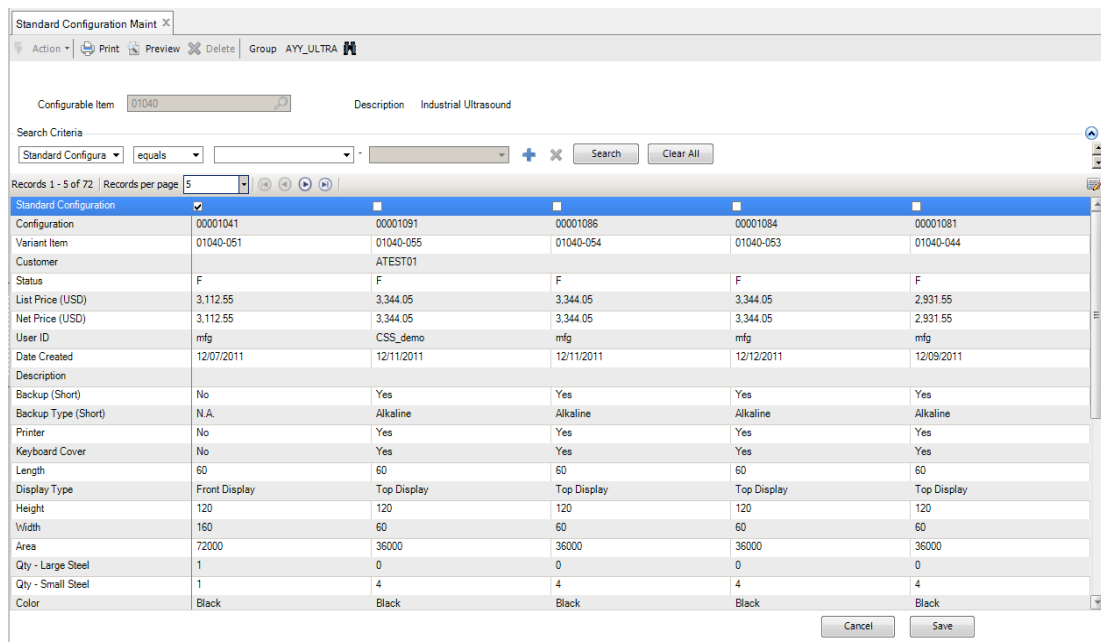

To use Standard Configuration Maintenance,

- 1 Select a group using the binocular button on the toolbar.
- 2 Specify a configurable item in the Configurable Item field; the system displays all available configurations of the configurable item for you to choose.
- 3 Browse through all available configurations; you can also use the search capabilities to search for configurations that meet your search criteria.

- 4 Select the check box above a Configuration ID to set the configuration as standard. You can set one or more standard configurations.
- 5 Click Save.

After you have standard configurations, the next time you use Standard Configuration Maintenance, the standard configurations are shown first, followed by non-standard configurations.

Note Standard configurations are not customer-specific.

Using Configurator Metrics

Configurator offers you a set of metrics to help you gauge how effectively you are using Configurator on a daily basis in order to reveal opportunities for improvement and make the best use of the product. This visual management tool lends at-a-glance insight into your performance level in using Configurator by graphically representing the following KPIs (Key Performance Indexes):

- Configurator Model Completeness
- Configurator Rules Completeness
- Configurator Operational Performance

Configurator Best Practices

Using Placeholder Component

In this scenario, the business is faced with very broad product structures; the product structures include a huge number of possible component items (or non-configured sub-assemblies) on one or more levels.

To deal with the situation, you can create a multilevel configuration with a placeholder configurable item where a component is then inserted.

- 1 Associate a placeholder component with the wanted product structure.
- 2 Make the placeholder component a configurable item of type BOM.
- 3 Define a feature that has the item number of the to-be-associated component.
- 4 Set up Variant Item Number Rule with element Feature and select the feature that you defined in the previous step.
- 5 Assign the item number to the new feature, which can be an item browse, a manual entry, an external entity lookup, or any other lookup or calculation.

See “Rebuild for Multi-level Configurations” on page 149 to see more information about multilevel configuration.

Using Base Price for Configurable Items in Questionnaire

The business scenario is that a configurable item has a base price; certain selected options are then added to the price.

In this situation, you can create a feature that retrieves the base price.

- 1 Define a feature, such as Model.
- 2 Add an option, which can be the item number or description of the configurable item.
- 3 Add the configurable item as a pricing part for the feature; you can either set up a price in the item master or a price list for the item.
- 4 Write an item rule of type Assignment that selects this option.

Populating Fields in Variant Item-Site Planning Records

In this scenario, item-site planning records that are created by Configurator for each variant item need to be updated with specific settings—for example, minimum order quantities.

To deal with the situation, you can create an external entity that populates variant item-site planning records.

- 1 Set up a configurable item that creates variant item-site records.
 - If you want to create item-site records for all sites defined for the configurable item, set Variant Item Site Record to All Sites.
 - If you want to create only one item-site record, set Variant Item Site Record to Current Site Only and create a variable/feature you reference in Site Variable.
- 2 Create an external entity to select the ptp_det record with the following selection rule (based on your setup in the previous step)
 - `ptp_domain = sysDomainID, ptp_part = sysVariantItemID, ptp_site = your site`
 - `ptp_domain = sysDomainID, ptp_part = sysVariantItemID, ptp_site = site variable`
- 3 Create an external entity rule that assigns values to your wanted ptp_ field.

Index

B

Batch Compiler 152

C

comments 21, 35
Component Effectivity Date Maintenance 139
Configurable Item Maintenance 47
Configurable Item Number Change 144
Configuration Analyzer 93
Configuration Control 43
Configuration Delete/Archive 143
configuration key 18
Configuration Key Maintenance 96
cost roll-up 21
cross validation 24
Cross Validation Analyzer 24, 25, 117
report 26

E

Element Roll-Up 22, 138
Element Roll-Up Rule Maintenance 113
External Entity Rule Maintenance 114

F

Feature Maintenance 67
feature relationships 13
feature sequence 17
Feature Sequence Maintenance 68
Functional Group Maintenance 60

G

General Rule Maintenance 71
General Rule Table Maintenance 83

I

Item Rule Maintenance 77
Item Rule Table Maintenance 90

M

Maintaining 139
Manual Configuration Maintenance 144
master group
about 44
maintain 45
Model Import/Export 140
multi-level analysis 17

P

process
product configuration 100
sales configuration 59
variant item configuration 123
process map
general 2
product configuration rules 19
item number definition rules 20

Q

Question Type Maintenance 59
questionnaire 26
configurations 27
questions 27
Questionnaire Sequence Maintenance 95

R

Routing Effectivity Date Maintenance 139
Rule Assistant 35
Rule Group Maintenance 76
rule statement formats 10
Rule Table Accelerator 92

S

Sales Configuration Rule Report 93
sales configuration rule table 79
sales configuration rules 9

T

toolbar 33
Trade Management, integration with 3

V

Variable Maintenance 60
variables and features
data types 7
options 8
sequences 16
Variant Item Number 101
Variant Item Number Rule Maintenance 103
Variant Routing Rule Maintenance 109
Variant SO Line Rule Maintenance 111
Variant SQ Line Rule Maintenance 112

W

Where-Used Report 97

