

MFG/PRO® eB

User Guide

Volume 6

MASTER FILES

ITEMS/SITES
PRICING
PRODUCT CHANGE CONTROL
COMPLIANCE
ADDRESSES
INTRASTAT
INVENTORY CONTROL
PHYSICAL INVENTORY
GLOBAL TAX MANAGEMENT



78-0507A
Printed in the U.S.A.
August 2000

This document contains proprietary information that is protected by copyright. No part of this document may be reproduced, translated, or modified without the prior written consent of QAD Inc. The information contained in this document is subject to change without notice.

QAD Inc. provides this material as is and makes no warranty of any kind, expressed or implied, including, but not limited to, the implied warranties of merchantability and fitness for a particular purpose. QAD Inc. shall not be liable for errors contained herein or for incidental or consequential damages (including lost profits) in connection with the furnishing, performance, or use of this material whether based on warranty, contract, or other legal theory.

MFG/PRO is a registered trademark of QAD Inc. QAD, QAD eQ, and the QAD logo are trademarks of QAD Inc.

Designations used by other companies to distinguish their products are often claimed as trademarks. In this document, the product names appear in initial capital or all capital letters. Contact the appropriate companies for more information regarding trademarks and registration.

Copyright ©2000 by QAD Inc.
78-0507A

QAD Inc.

6450 Via Real
Carpinteria, California 93013
Phone (805) 684-6614
Fax (805) 684-1890
<http://www.qad.com>

Contents

| | |
|--|-----------|
| ABOUT THIS GUIDE | 1 |
| Other MFG/PRO eB Documentation | 2 |
| Online Help | 3 |
| QAD Web Site | 3 |
| Conventions | 4 |
| | |
| CHAPTER 1 INTRODUCTION TO MASTER FILES..... | 5 |
| Items/Sites | 6 |
| Pricing | 6 |
| Product Change Control (PCC) | 7 |
| Compliance | 7 |
| Addresses | 7 |
| Intrastat | 7 |
| Inventory Control | 8 |
| Physical Inventory | 8 |
| Global Tax Management (GTM) | 8 |
| | |
| SECTION 1 MASTER FILES..... | 9 |
| | |
| CHAPTER 2 ITEMS/SITES..... | 11 |
| Introduction | 12 |
| Items | 13 |
| General Item Data | 15 |

| | |
|--|----|
| Codes and Master Comments | 17 |
| Inventory Data | 17 |
| Shipping Data | 19 |
| Planning Data | 20 |
| Cost Data | 21 |
| Customer and Supplier Items | 22 |
| Product Lines | 22 |
| Product Line Maintenance | 23 |
| Product Line Accounts | 24 |
| Alternate Product Line Accounts | 25 |
| Sites | 27 |
| Taxes | 27 |
| Sites and Enterprise Material Transfer (EMT) | 27 |
| Sites and Multiple Databases | 28 |
| Site Security | 28 |
| Locations | 30 |
| Permanent/Temporary Locations | 31 |
| Automatic Locations | 31 |
| Single Item Locations | 32 |
| Location Types | 32 |
| Inventory Status Codes | 32 |
| Status Defaults | 33 |
| Overissue Policy | 34 |
| Restricting Transactions | 35 |

CHAPTER 3 PRICING 37

| | |
|---|----|
| Introduction to MFG/PRO eB Pricing | 38 |
| Using Best Pricing | 40 |
| Planning for Best Pricing | 41 |
| Setting Pricing Defaults | 43 |
| Setting Up Analysis Codes | 44 |
| Setting Up Item Price Break Categories | 51 |
| Creating and Maintaining Price Lists | 52 |
| Repricing Orders in Sales Order Repricing | 71 |

| | |
|--|-----------|
| Repricing in Sales Order Maintenance | 74 |
| Understanding Sales Order Maintenance Fields | 76 |
| Using List/Discount Table Pricing | 78 |
| Creating Price Lists | 79 |
| Generating Price Lists by Item | 82 |
| Copying Price Lists | 84 |
| Processing List/Discount Prices | 87 |
| Pricing Setup | 88 |
| CHAPTER 4 PRODUCT CHANGE CONTROL..... | 89 |
| Introduction | 90 |
| PCR/PCO Life Cycle | 93 |
| PCR Life Cycle | 93 |
| PCO Life Cycle | 94 |
| Setting Up PCC | 96 |
| Preparing Data for Use with PCC | 97 |
| Setting Up the PCC Control File | 98 |
| Defining Groups, Routing Slips, and Change Types | 99 |
| Creating PCRs and PCOs | 109 |
| Using PCR/PCO Function Maintenance | 111 |
| Maintaining Text Files | 113 |
| Maintaining Item Files | 113 |
| Maintaining Product Structure Files | 115 |
| Maintaining Routing Files | 117 |
| Maintaining Formula Files | 118 |
| Maintaining Process Files | 119 |
| Maintaining Item Specifications | 119 |
| Maintaining Trailers | 120 |
| Reviewing PCO Data | 121 |
| Routing PCRs and PCOs for Approval | 122 |
| Approving PCRs and PCOs | 123 |
| Rerouting PCOs | 124 |
| Detail Approval Maintenance | 124 |
| Incorporating PCOs into Production | 124 |

| | |
|--|-----|
| PCO Release and Distribution | 125 |
| Incorporation Planning Report | 126 |
| Incorporation Selection | 127 |
| Incorporation | 128 |
| Implementation | 129 |
| Closing PCRs and PCOs | 129 |
| Importing and Exporting PCRs and PCOs | 130 |
| Setting Up PCC Security | 130 |
| Access to PCO Maintenance Detail Functions | 131 |
| Restricting Access to Other Functions | 131 |

CHAPTER 5 COMPLIANCE..... 133

| | |
|--|-----|
| Introduction | 134 |
| Site Security | 134 |
| Inventory Attributes | 135 |
| Batch Control | 135 |
| Component Issue Control | 135 |
| Lot Control | 135 |
| Multi-Lot Inventory Detail | 136 |
| Controlled Substances | 136 |
| Setting Up Compliance | 136 |
| Defining Inventory Attributes | 139 |
| Why Are Attributes Important? | 140 |
| Inventory Attributes Work Flow | 142 |
| Attribute Descriptions | 142 |
| Inventory Attribute Active Field | 144 |
| Using Work Order Batch Control | 147 |
| Batch Control Work Flow | 148 |
| Assigning Batch Numbers to Work Orders | 148 |
| Changing Inventory Detail Records | 149 |
| Using Lot Control | 151 |
| Lot Control Work Flow | 152 |
| Lot Control Relationships | 153 |
| Deciding on Lot Control Level | 154 |

| | |
|--|------------|
| Building the Lot Master File | 155 |
| Modifying the Lot Master File | 155 |
| Automatic Lot Numbering | 156 |
| Single Lot per Receipt | 159 |
| Supplier Lot Numbers | 160 |
| Expired Inventory Transactions | 161 |
| Managing Component Issues | 162 |
| Component Issue Control | 162 |
| Co-product/By-product Component Issue Control | 162 |
| Managing Controlled Substances | 162 |
| Entering Country Codes | 164 |
| Entering Authority Codes | 165 |
| Entering Control Numbers for Customers and Sites | 165 |
| Entering Control Numbers for Items | 166 |
| Entering General License Information | 167 |
| Entering Individual License Information | 168 |
| CHAPTER 6 ADDRESSES | 169 |
| Introduction | 170 |
| Address List Types | 172 |
| Setting Up Company Addresses | 173 |
| Company Banks | 173 |
| Company Addresses for Purchase Orders | 174 |
| Company Address and GTM | 174 |
| Setting Up Salesperson Addresses | 174 |
| Setting Up Customer Addresses | 175 |
| Customer Data | 177 |
| Customer Credit Data | 177 |
| Customer Freight Data | 178 |
| Other Customer Data | 179 |
| Adjusting Credit Limits | 179 |
| Setting Up Supplier Addresses | 180 |
| Setting Up Employee Addresses | 181 |
| Setting Up Carrier Addresses | 181 |

| | |
|---|-----|
| Setting Up Customer/Supplier Bank Addresses | 182 |
| Setting Up Credit Terms and Trailer Codes | 184 |
| Proximo Terms | 185 |
| Base Date | 187 |
| Credit Terms Interest | 187 |
| Base Days | 188 |
| Trailer Codes | 189 |
| Setting Up Freight Charges | 189 |
| Freight List Maintenance | 190 |
| Freight Zone Maintenance | 191 |
| Freight Class Maintenance | 192 |
| Freight Charges Maintenance | 192 |
| Freight Terms Maintenance | 193 |
| Changing or Merging Address Codes | 194 |

CHAPTER 7 INTRASTAT 197

| | |
|--|-----|
| Introduction | 198 |
| Implementing Intrastat | 200 |
| Setting Up Intrastat Codes | 201 |
| Setting Up Addresses for Declarants and Agents | 202 |
| Setting Up the Intrastat Control File | 202 |
| Setting Up Commodity Codes | 205 |
| Setting Up Intrastat Item Data | 206 |
| Setting Up a Company Address for Each Site | 207 |
| Entering Country Codes for Customers and Suppliers | 207 |
| Entering Net Weights for Intrastat Items | 208 |
| Recording Intrastat Data for Orders | 208 |
| Entering Intrastat Data in Sales Order Maintenance | 208 |
| Entering Data in Order Intrastat Data Maintenance | 210 |
| Manually Creating Intrastat History | 211 |
| Printing Intrastat Declarations | 212 |
| Reprinting Intrastat Declarations | 214 |
| Reviewing Intrastat History Information | 214 |
| Deleting and Archiving Intrastat History | 215 |

| | |
|--|------------|
| Types of Intrastat Data | 215 |
| CHAPTER 8 INVENTORY CONTROL | 217 |
| Introduction | 218 |
| Setting Up the Inventory Control File | 218 |
| Creating Inventory Detail Records | 220 |
| Creating Inventory Transactions | 220 |
| Transfers | 221 |
| Receipts | 222 |
| Issues | 223 |
| Shipping Documents | 223 |
| Creating Inventory Transaction History | 223 |
| Transaction Types | 224 |
| Reviewing Transaction History | 225 |
| Creating Lot/Serial Number History | 226 |
| Performing Cycle Counts | 227 |
| ABC Class Code | 228 |
| Cycle Counting Procedure | 228 |
| Creating Inventory Reports | 230 |
| Stock Status Report | 230 |
| Reorder Report | 230 |
| Item ABC Status Report/Update | 230 |
| Inventory Detail Report | 231 |
| Inventory Detail by Location | 231 |
| Current Surplus Inventory Report | 231 |
| Projected Surplus Inventory | 232 |
| Inventory Valuation Reports | 232 |
| Checking Inventory Availability | 233 |
| CHAPTER 9 PHYSICAL INVENTORY | 235 |
| Introduction | 236 |
| Deleting/Archiving Old Tags | 236 |
| Freezing Inventory Balances | 237 |
| Creating/Printing Tags | 237 |

Entering Initial Tag Counts 238
 Reviewing Results 239
 Zeroing/Voiding Unused Tags 239
 Updating Inventory Balances 240

SECTION 2 GLOBAL TAX MANAGEMENT 241

CHAPTER 10 INTRODUCTION TO GTM 243

Global Tax Management 244
 Features 244
 Considerations 245
 Tax Elements 245

CHAPTER 11 IMPLEMENTING GTM 247

Implementation Overview 248
 Setting Up Tax Jurisdictions 249
 Setting Up Country Codes 249
 Setting Up State, Province, County Codes 250
 Setting Up Tax Zones 250
 Setting Up Tax Types 254
 Setting Up Tax Classes and Usages 254
 Setting Up Rounding Methods 256
 Setting Up Tax Environments 258
 Setting Up Trailer Charges 261
 Setting Up Tax Bases 263
 Setting Up GL Accounts 265
 Setting Up Tax Rates 266
 Tax Rate Maintenance 267
 Tax Rate Copy/Update 271
 Setting Up the GTM Control File 272
 Updating Other MFG/PROeB Records 274
 Company and Site Addresses 274
 Customers, Suppliers, and End Users 274

| | |
|---|------------|
| Product Lines and Items | 276 |
| Implementing Special Taxes | 276 |
| Tax Exemptions | 276 |
| Tax Based on Partial Item Amounts | 278 |
| Custom Tax Calculation Methods | 278 |
| Luxury Taxes | 280 |
| Capped Taxes | 280 |
| Recoverable Taxes | 280 |
| Tax-on-Tax | 281 |
| Discounted Taxes | 282 |
| Retained Taxes | 283 |
| Absorbed Taxes | 283 |
| Reverse-Calculated Taxes | 283 |
| CHAPTER 12 PROCESSING GTM..... | 287 |
| Calculating Taxes | 288 |
| Specifying Tax Data | 291 |
| Viewing Tax Amounts | 293 |
| Correcting Transaction Tax Amounts | 295 |
| General Ledger Effects | 296 |
| Standard Cost | 297 |
| Average Cost | 308 |
| Reporting | 319 |
| Printing Tax Information on Documents | 319 |
| Tax Reports | 319 |
| Fixing Common Tax Problems | 320 |
| INDEX | 321 |

About This Guide



- Other MFG/PRO eB Documentation* 2
- Online Help* 3
- QAD Web Site* 3
- Conventions* 4



Routing Maintenance (Date Based)

| | | |
|---------------------|---------------------|----------------------|
| Routing Code: | 10-15000 | MANUFACTURE COOLING |
| Operation: | 20 | |
| Standard Operation: | | |
| Work Center: | 1030 | INSPECTION, ALL SITE |
| Machines: | | |
| Description: | INSPEC PER PROC-000 | |
| Machines per Op: | 1 | |
| Overlap Units: | 1 | |
| Queue Time: | 1.0 | |
| Wait Time: | 0.0 | |
| Setup Time: | 0.0 | |

Route to Production...

This guide covers the modules and functions included under the Master Files icon on the main menu of MFG/PRO eB for Windows.

Other MFG/PRO eB Documentation

- For an overview of new features and software updates, see the *Release Bulletin*.
- For software installation instructions, refer to the appropriate installation guide for your system.
- For instructions on navigating the MFG/PRO eB Windows and character environments, refer to *User Guide Volume 1: Introduction*. Navigation information for the Network User Interface (NetUI) is provided in the *Network User Interface Guide*.
- For information on using MFG/PRO eB, refer to the *User Guides*.
- For information on using features that let MFG/PRO eB work with external applications, see the *External Interface Guides*. For example, these guides describe the Warehousing application program interface (API) and Q/LinQ, the tool set for building and using tools that perform complex data exchange between MFG/PRO eB and external systems.
- For technical details, refer to *File Relationships* and *Database Definitions*.
- To view documents online in PDF format, see the *Documents on CD*. The CD-ROM media includes complete instructions for loading the documents on a Windows network server and making them accessible to client computers.

Note MFG/PRO eB installation guides are not included on *Documents on CD*. Printed copies are packaged with your software. Electronic copies of the latest versions are available on QAD's Web site.

Online Help

MFG/PROeB has an extensive online help system. Help is available for most fields found on a screen. Procedure help is available for most programs that update the database. Most inquiries, reports, and browses do not have procedure help.

For information on using the help system in the different MFG/PROeB environments, refer to *User Guide Volume 1: Introduction* and the *Network User Interface Guide*.

QAD Web Site

QAD's Web site provides a wide variety of information about the company and its products. You can access the Web site at:

<http://www.qad.com>

For MFG/PROeB users with a QAD Web account, product documentation is available for viewing or downloading at:

<http://support.qad.com/documentation/>

To obtain a QAD Web account, go to:

<http://support.qad.com/>

Most user documentation is available in two formats:

- **Portable document format (PDF).** PDF files can be downloaded from the QAD Web site to your computer. You can view them with the free Adobe Acrobat Reader. A link for downloading this program is also available on the QAD Web site.
- **HTML.** You can view user documentation through your Web browser. The documents include search tools for easily locating topics of interest.

Features also include an online solution database to help MFG/PROeB users answer questions about setting up and using the product. Additionally, the QAD Web site has information about training classes and other services that can help you learn about MFG/PROeB.

Conventions

MFG/PROeB is available in several interfaces: Windows, character, Web browser, and an interface for object-oriented programs. To standardize presentation, the documentation uses the following conventions:

- MFG/PROeB screen captures show the Windows interface.
- References to keyboard commands are generic. For example, choose Go refers to F2 in the Windows interface and to F1 in the character interface. Throughout MFG/PROeB, the PROGRESS status line at the bottom of the program window lists the main UI-specific keyboard commands used in that program.

For complete keyboard command summaries for each MFG/PROeB interface, refer to the appropriate chapters of *User Guide Volume 1: Introduction* and the *Network User Interface Guide*.

This document uses the text or typographic conventions listed in the following table.

| If you see: | It means: |
|--------------------------------------|--|
| monospaced text | A command or file name. |
| <i>italicized</i> monospaced text | Indicates a variable name for a value you enter as part of an operating system command. For example, <i>YourCDROMDir</i> . |
| indented command line | A long command that you enter as one line, although it appears in the text as two lines. |
| Note | Alerts the reader to exceptions or special conditions. |
| Important | Alerts the reader to critical information. |
| Warning | Used in situations where you can overwrite or corrupt data, unless you follow the instructions. |

Introduction to Master Files

Master files provide data to other MFG/PRO eB programs. This chapter gives an overview of master files.

Items/Sites **6**

Pricing **6**

Product Change Control (PCC) **7**

Compliance **7**

Addresses **7**

Intrastat **7**

Inventory Control **8**

Physical Inventory **8**

Global Tax Management (GTM) **8**

| | | |
|---------------------|---------------------|----------------------|
| Routing Code: | 10-15000 | OPERATION: CH01.01 |
| Operation: | 20 | |
| Standard Operation: | 1030 | INSPECTION, ALL SITE |
| Work Center: | | |
| Machine: | | |
| Description: | INSPEC PER PROX-000 | |
| Machines per Op: | 1 | |
| Overlap Units: | 1 | |
| Queue Time: | 1.0 | |
| Wait Time: | 0.0 | |
| Setup Time: | 0.0 | |

Master files provide basic business information to other MFG/PRO eB programs. Figure 1.1 shows the master files programs discussed in this volume.

Fig. 1.1
Master Files

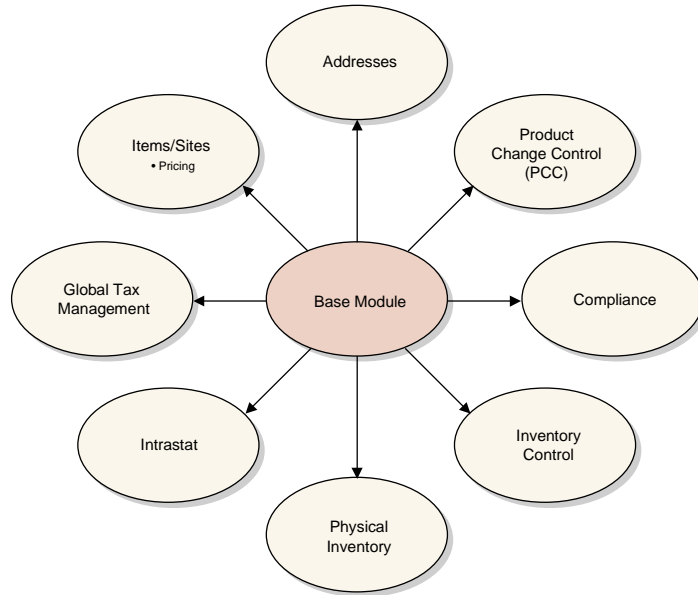

Items/Sites

▶ See Chapter 2, “Items/Sites,” for details.

Items and sites are the foundation of all MFG/PRO eB modules. The master files in the Item/Sites module define manufacturing and distribution sites, inventory locations, product lines and items. Customer and supplier item numbers are also defined, with pricing for each. Unit of measure conversions defined here support entry of alternate units of measure in other transactions.

Pricing

▶ See Chapter 3, “Pricing,” for details.

Pricing master files allow automatic pricing by providing price lists during key transactions. Two basic pricing models are used: best pricing model and list/discount pricing.

Product Change Control (PCC)

Product Change Control (PCC) is a flexible information storage tool to control and monitor product changes from inception through implementation. Item engineering data, product structures, routings, formulas, processes, and item specifications can be modified in PCC without affecting the rest of MFG/PRO eB. Use PCC to define approval cycles for product changes before the changes are incorporated into production files.

▶ See Chapter 4, “Product Change Control,” for details.

Compliance

Compliance lets companies manage compliance with government regulations such as the FDA Current Good Manufacturing Practices, and with international agreements such as NAFTA and GATT.

▶ See Chapter 5, “Compliance,” for details.

Addresses

The Addresses master files define customers, suppliers, salespersons, employees, carriers, banks, and company addresses. All address information is stored and maintained in these files. Also use Addresses to define freight charges, credit terms, trailer codes.

▶ See Chapter 6, “Addresses,” for details.

Shipping groups and documents are also defined in the Addresses/Taxes module. These records are used exclusively with shipping functions.

▶ See *User Guide Volume 2: Distribution*.

Intrastat

Intrastat offers data collection and reporting tools for companies doing business in European Union member countries and for companies requiring written documentation of inventory movement. Intrastat collects data in a history file whenever there is sales or purchasing activity, then uses the data to generate Intrastat reports.

▶ See Chapter 7, “Intrastat,” for details.

Inventory Control

▶ See Chapter 8, “Inventory Control,” for details.

Inventory Control receives transactions from other MFG/PRO eB applications and provides balance and availability information where needed. It tracks intersite transfers and their financial consequences, such as cost variances, and automatically posts intercompany transfers.

Physical Inventory

▶ See Chapter 9, “Physical Inventory,” for details.

Physical Inventory lets you conduct physical counts of all inventory items.

Global Tax Management (GTM)

▶ See Section 2, “Global Tax Management,” beginning on page 241 for details.

GTM offers precise tax calculations and flexible setup for calculating taxes for multiple countries. With GTM, you can set up an unlimited number of taxes and rates—each associated with customers, suppliers, or items. You can also define when taxes are calculated, the formula used to calculate them, and the amount subject to tax.

SECTION 1

Master Files

This section describes how to set up and use the master file records that form the base data in your MFG/PRO eB database.

Items/Sites **11**

Pricing **37**

Product Change Control **89**

Compliance **133**

Addresses **169**

Intrastat **197**

Inventory Control **217**

Physical Inventory **235**

Routing Maintenance (Main Screen)

| | | |
|---------------------|---------------------|----------------------|
| Routing Code: | 10-15000 | MANUFACT: CHILIN |
| Operation: | 20 | |
| Standard Operation: | | |
| Work Center: | 1030 | INSPECTION, ALL SITE |
| Machines: | | |
| Description: | INSPEC PER PROC-000 | |
| Machines per Op: | 1 | |
| Overlap Units: | 1 | |
| Queue Time: | 1.0 | |
| Wait Time: | 0.0 | |
| Setup Time: | 0.0 | |
| Ready Production: | | |

Items/Sites

This chapter discusses two essential elements in product definition: items and product lines. Item records are used to define the actual products that are kept in inventory and/or planned by planning functions. Product lines group items for planning and accounting purposes. In addition, sites, locations, and inventory status codes are introduced.

Introduction **12**

Items **13**

Product Lines **22**

Sites **27**

Locations **30**

Inventory Status Codes **32**

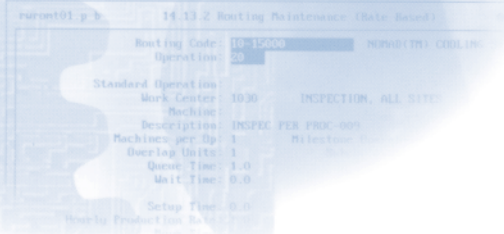

Routing Maintenance (Main Screen)

| | | |
|----------------------|---------------------|----------------------|
| Routing Code: | 10-15000 | MANUFACTURE CHAIN |
| Operation: | 20 | |
| Standard Operation | | |
| Work Center: | 1030 | INSPECTION, ALL SITE |
| Machines: | | |
| Description: | INSPEC PER PROC-000 | |
| Machines per Op: | 1 | |
| Overlap Units: | 1 | |
| Queue Time: | 1.0 | |
| Wait Time: | 0.0 | |
| Setup Time: | 0.0 | |
| Ready to Production: | | |

Introduction

Item/site information supplies a foundation for many other functions in MFG/PRO eB. Figure 2.1 illustrates how items and sites are central to other processes.

Fig. 2.1
Items/Sites



This chapter discusses four foundational elements in MFG/PRO eB:

Sites. All inventory related functions within MFG/PRO eB can be done by site. A site may be a manufacturing or distribution facility that requires separate planning and inventory control.

Locations. Within each site, inventory is held in locations. These may be temporary or permanent, and they may be assigned rules which govern how inventory in the location can be issued or received.

Items. Items are defined for use throughout the system. The characteristics of an item include inventory data such as ABC class and shelf life, planning data such as order policies and lead time, and price and cost data. The same item may have different characteristics at each site.

Product Lines. For planning and reporting purposes, items are grouped by product line.

Items

Item records are created primarily for items and products that are stored in inventory and/or planned by Material Requirements Planning (MRP) or Distribution Requirements Planning (DRP). At this time, items are assigned to product lines and default data used in inventory control, sales, purchasing, planning, and costing is loaded. You can customize costs and other information by company site once you set up the initial record.

Figure 2.2 shows the major elements that are implemented during product definition, in the order they are set up. Only product lines and items are mandatory. Usage of the other elements varies by company and is described in other chapters.

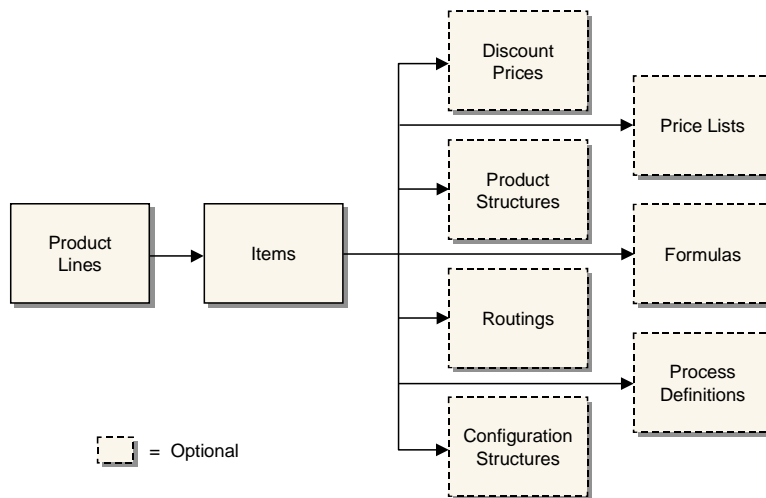

Fig. 2.2
Product Definition
Flow

Item data is divided into four categories that roughly parallel how companies typically divide up the maintenance responsibility. Table 2.1 lists the data types and responsible departments.

Table 2.1
Item Data

| Data Type | Responsible Department |
|------------------|---|
| General Data | Product Engineering or Research and Development |
| Inventory Data | Inventory Control or Materials Management |
| Planning Data | Material Planning |
| Cost Data | Cost Accounting |

Because some information serves multiple programs, a field that is the responsibility of one particular organization within your company may not be where you expect it. For example, the default list price for a product might be determined by the sales department, but in MFG/PRO eB, this field is considered cost data, normally maintained by accounting.

To support this potential division of responsibilities, there are two ways to load item master data:

- From Item Master Maintenance (1.4.1), you can enter all item data. This is the only program that can be used to create new item numbers. This method is the most convenient.
- From separate programs, you can create the item record (1.4.3), then enter planning data (1.4.7), inventory data (1.4.5), and cost data (1.4.9). This method offers the most security, because access to the individual programs can be password-restricted.

If your company manages the same items at multiple sites, you can control, plan, and cost items separately for each site. Data can be differentiated by site using the item-site data programs (1.4.16, 1.4.17, 1.4.18). Programs that process an item at a particular site first looks for item data specific for the site. If none is found, the system uses the item master record.

Internally, the system requires one and only one item master record for each item. Item-site data is optional.

General Item Data

Every item has some relatively static information that describes its general characteristics, regardless of how it is used. This includes the item's description, product line, unit of measure, drawing, revision, status, and so on.

Any general data you set up for an item must be valid for all sites in the system, since this data cannot be defined per site. If general item data for an item varies by site, you must set up the item with different item numbers.



Fig. 2.3
Item Master
Maintenance
(1.4.1), Item Data

The item number, description, product line, and unit of measure (UM) are the most visible and most important engineering fields.

The item number is the index for item data. Whenever you enter a number in an Item field, it is validated against numbers in the item master. The fields for unit of measure, group, type, and status permit virtually any combination of characters. Most of these fields are validated with generalized codes, and look-up browses can be set up.

◆ See *User Guide Volume 9: Manager Functions* for details on generalized codes.

Item Number and Description

Most companies have not escaped controversy when determining conventions for item numbering and item descriptions. Proponents of significant, semi-significant, and nonsignificant item numbering schemes argue the advantages and disadvantages of coding information into an item number.

With MFG/PRO eB, any numbering scheme is possible. Using a significant numbering scheme may be less important because users have access to help windows that can be searched by item number or description. This works best when you ensure that descriptions are

consistent with each other. Browsers can be easily customized to sort by any field.

Item Unit of Measure

The item unit of measure (pt_um) is used for inventory balances, product structures, manufacturing orders, planning, and reporting. Values can be defined with generalized codes.

Different areas of a company may handle an item using different units of measure. For example, an item may be moved in pallets but sold by the box. For these cases, set up alternate units of measure and conversion factors in Unit of Measure Maintenance (1.13).

When items are handled in different units of measure on purchase orders, sales orders, and inventory transactions, the system automatically converts the quantities from an alternate unit of measure to the item unit of measure using the predefined conversion factors. In most cases, either unit may be entered on transactions.

The formula for alternate unit of measure is:

$$\text{Standard UM} * \text{Conversion} = \text{Alternate UM}$$

Grouping Fields

If grouping items by product line does not satisfy the planning and reporting requirements of all company departments, the item type and group fields can also be used to group items. Both fields are used in the planning and sales modules. The item type is also used for product costing functions and cycle count reporting.

The promo group indicates an item is priced using the Advanced Pricing Management (APM) module. Design groups are used in the Product Change Control module to determine who is responsible for changes affecting the item.

Codes and Master Comments

Codes such as group and type are useful because they provide a short, convenient way to categorize and identify items. However, more extensive information related to an item may be needed. For example, Product Engineering maintains information concerning the implementation of engineering change orders for an item. Purchasing tracks specific supplier requirements and Quality Engineering stores inspection-related text.

These requirements can be met by recording master comments. Each master comment can have up to 99 pages of text. Master comments are identified by reference, type, and language codes. When master comments are added for an item, the item number is entered as the reference code.

Use the Type field to identify different master comment records for the same item number. For example, the type codes PE, PO, and QE can be used for Product Engineering, Purchasing, and Quality Engineering. To review all the master comments entered for an item, print the Item Master Comments Report (1.5.12).

Master comments do more than store and organize textual information for an item. They can also be copied into documents such as purchase orders, sales quotations, and sales orders.

Inventory Data

Inventory control is responsible for the security, movement, accuracy, and, in some cases, the allocation of inventory. Every item has inventory control information associated with it. The system uses this information to track and control the movement of the item. For example, if an item has an expiration date, you cannot issue the item after that date.

| Item Inventory Data | | | | | |
|---------------------|--|----------------------|----------------------------------|---------|---------------------------------|
| ABC Class: | <input type="text" value="A"/> | Avg Int: | <input type="text" value="90"/> | | |
| Lot/Serial Control: | <input type="text"/> | Cyc Cnt Int: | <input type="text" value="120"/> | | |
| Site: | <input type="text" value="20000"/>  | Shelf Life: | <input type="text"/> | | |
| Location: | <input type="text" value="100"/> | Allocate Single Lot: | <input type="text" value="no"/> | | |
| Location Type: | <input type="text"/> | Key Item: | <input type="text" value="no"/> | | |
| Auto Lot Numbers: | <input type="text" value="no"/> | PO Rcpt Status: | <input type="text"/> | Active: | <input type="text" value="no"/> |
| Lot Group: | <input type="text"/> | WD Rcpt Status: | <input type="text"/> | Active: | <input type="text" value="no"/> |
| Article Number: | <input type="text"/> | | | | |

Fig. 2.4
Item Master
Maintenance
(1.4.1), Item
Inventory Data

The following briefly explains how inventory control fields are used.

ABC Class Code. This code classifies items by level of importance, such as dollar value, with class A being the most important. The system uses the ABC class code with cycle counting. You can add the code directly or leave it blank. If left blank, you can have the system calculate an item's ABC class code by running the Item ABC Status Report/Update (1.5.9 or 3.6.3).

Lot/Serial Control. The Lot/Serial Control field determines whether the item must have a lot or serial number when you process receipts or issues for it.

- If set to L (Lot), you cannot issue or receive the item without a lot number.
- If set to S (Serial), you cannot issue or receive the item without a serial number.

If left blank, lot/serial numbers are not required for the item, but you can record them if you want.

Additional lot/serial control can be implemented if you are using the Compliance module.

Site. The site where you normally manufacture or store the item. The site defaults from the Inventory Control File (3.24), but can be overridden.

Location. This location displays as the default for inventory transactions for the item.

Location Type. Type identifies special storage requirements of the item such as flammable, humidity controlled, outside. If you assign the item a location type, it can only be received into a location that matches.

Automatic Lot Numbers. This field determines if the system assigns lot numbers automatically. If Yes, the system assigns the work order number as the lot number. If you are using the Compliance module, lot numbers can be generated based on a lot group format.

Average Interval. The number of calendar days used as the averaging interval in ABC computations.

▶ See “Using Lot Control” on page 151 for details.

▶ See “Locations” on page 30 for details.

▶ See Chapter 5, “Compliance,” for information on lot groups.

Cycle Count Interval. The number of calendar days between cycle counting this item.

Shelf Life. Shelf life indicates the number of calendar days you can hold the item in inventory before it becomes unusable. The system adds this figure to the item's receipt date to calculate the expiration date. You cannot allocate, ship, or issue expired inventory.

Allocate Single Lot. This field indicates whether the system should always fill sales orders and work orders from a single lot of this item. If Yes, you can manually allocate orders from more than one lot using Sales Order Manual Allocations (7.1.6) or Work Order Bill Maintenance (16.13.1), but the system displays a warning message.

Key Item. Indicates if this item must be available before a work order can be released. If Yes, the system does not release work orders and print picklists until there is enough of the item to allocate.

PO Receipt Status. A default inventory status for the item when received on a purchase order. This field is optional. If not specified, the status of the location or site is used as a default.

♦ See “Inventory Status Codes” on page 32.

WO Receipt Status. A default inventory status for the item when received on a work order. This field is optional. If not specified, the status of the location or site is used as a default.

Shipping Data

The shipping department uses item shipping data to determine freight charges. For example, freight charge calculations use the item's shipping weight to determine freight costs.

♦ See “Setting Up Freight Charges” on page 189.



| Item Shipping Data | |
|--------------------|--------------------------------|
| Corp Comm Code: | <input type="text"/> |
| Ship Weight: | 1.00 <input type="text"/> lb |
| Freight Class: | <input type="text"/> |
| Net Weight: | 1.00 <input type="text"/> KG |
| Volume: | 100.00 <input type="text"/> CI |

Fig. 2.5
Item Master Maintenance (1.4.1), Item Shipping Data

In some business environments, it is a common practice to use commodity codes to group items for internal business needs. For example, all suppliers providing a certain kind of commodity—represented by a commodity code—may be rated together, regardless of the particular item.

▶ See “Setting Up Commodity Codes” on page 205 for details about Intrastat codes.

Note Corporate commodity codes are distinct from the commodity codes used to classify goods for Intrastat reporting purposes.

Create valid commodity codes and associate groups of items with them in Commodity Code Maintenance (1.4.19). The associated code then displays in Item Master Maintenance and can be modified if needed.

Planning Data

▶ For details about MRP, see *User Guide Volume 3: Manufacturing*.

The material planning department uses item planning data to determine how and when to replenish inventory. This data affects MRP, purchasing, manufacturing (work orders, repetitive schedules, and master scheduling), configured products, and costing. Most of the fields are used in material requirements planning (MRP).

Fig. 2.6
Item Master Maintenance (1.4.1), Item Planning Data

| Item Planning Data | | | | | |
|--------------------|------------------------------|----------------|-----------------------------|----------------------|-----------------------------|
| Master Sched: | <input type="checkbox"/> yes | Buyer/Planner: | <input type="text"/> | Phantom: | <input type="checkbox"/> no |
| Plan Orders: | <input type="checkbox"/> yes | Supplier: | <input type="text"/> | Min Ord: | <input type="text"/> |
| Time Fence: | <input type="text"/> | PO Site: | 10000 | Max Ord: | <input type="text"/> |
| MRP Required: | <input type="checkbox"/> yes | Pur/Mfg: | M | Ord Mult: | <input type="text"/> |
| Order Policy: | POQ | Configuration: | ATO | Yield%: | 100.00% |
| Order Qty: | <input type="text"/> | Mfg LT: | 1 | Run Time: | <input type="text"/> |
| Batch Qty: | 1.0 | Pur LT: | <input type="text"/> | Setup Time: | <input type="text"/> |
| Order Period: | 7 | Inspect: | <input type="checkbox"/> no | EMT Type: | NON-EMT |
| Safety Stk: | <input type="text"/> | Ins LT: | <input type="text"/> | Auto EMT Processing: | <input type="checkbox"/> on |
| Safety Time: | <input type="text"/> | Cum LT: | 0 | Network Code: | <input type="text"/> |
| Reorder Point: | <input type="text"/> | Run Seq 1: | <input type="text"/> | Routing Code: | <input type="text"/> |
| Rev: | AA | Run Seq 2: | <input type="text"/> | BOM/Formula: | <input type="text"/> |
| Issue Policy: | <input type="checkbox"/> yes | | | | |

The Pur/Mfg (purchase/manufacture) code determines how items are planned, costs are calculated, and cumulative lead times are calculated. This code can be:

- Purchased: obtained from suppliers
- Manufactured: produced internally, typically with work orders
- Line: produced internally, typically on a production line
- Routable: produced internally
- Distribution: obtained from distribution sites
- Configured: configured to customer order and produced internally
- Family: a special type of item used for operations planning

The system assumes items with a blank Pur/Mfg code are manufactured.

Cost Data

The item cost data is divided into three sections:

- Price and tax data
- General ledger (GL) cost
- Current cost

Price

Price and costs are entered in base currency specified in the System/Account Control File. The item master price is the default list price in sales transactions, if price lists are not being used. You can only assign one list price directly to an item.

▶ See Chapter 3, “Pricing,” for details on using price lists.

The taxable status and tax code default from the product line and are used in the Purchasing, Sales Orders/Invoices, and Customer Services modules.

GL and Current Costs

The item GL costs are the standard costs used for GL transactions. Both the GL costs and current costs are the costs for the item at the site specified in the inventory data section.

In turn, each of these costs has five cost categories: material, labor, burden, overhead, and subcontract. Burden is sometimes known as variable burden or variable overhead. Overhead is known as fixed burden or fixed overhead. Use Item-Site Cost Maintenance (1.4.18) to update the GL and current costs for a particular site.

Both the GL and current costs can be updated automatically during routing and product structure roll-ups by using item cost utilities in the Item Data Menu (1.4) or by using cost simulation programs in the Cost Management module.

▶ These programs are discussed in *User Guide Volume 4A: Financials*.

Customer and Supplier Items

A customer may prefer to order using their own item number or an industry standard number rather than the one your company uses.

Example Contractors may be required to order with a government procurement code instead of your item number.

Use Customer Item Maintenance (1.16) to set up a cross-reference between your item numbers and those used by a customer. When a customer item number is specified on a sales order, the system accesses the price, description, and other information associated with your item number. Both item numbers appear on all sales and shipping paperwork.

You can also use Customer Item Maintenance to set up a cross-reference between internal numbering systems. For example, your sales department may have catalog numbers that differ from the item numbers used by manufacturing. To set up an internal cross-reference, leave the Customer/Ship-to field blank.

The same need to cross-reference numbers may exist for your suppliers. Use Supplier Item Maintenance to create a cross-reference between your suppliers' numbers and your item numbers, as well as track the quoted price and lead time. Specify supplier item numbers in Blanket Order Maintenance, Purchase Order Maintenance, and Scheduled Order Maintenance. Both your number and the supplier number displays on reports, as well as in Purchase Order Receipts.

Product Lines

A product line is a group of similar items or products. At the corporate level, a company's sales and operations are often planned, reported, and analyzed by product line rather than by individual item or product. This higher-level view of activity makes it easier to relate day-to-day operations to the company sales and operations plan.

By dealing with an aggregate, it is sometimes possible to get a clearer, more accurate picture. For example, a shipment forecast for a product line is more accurate than a forecast for a specific item.

Before you define product lines, you should determine the most important criteria for grouping items. Unfortunately, different departments usually

want to divide items differently. For example, Sales may want to group products by target market, but Manufacturing wants to group products by production method.

Product lines group items for accounting and planning purposes:

- Each product line is associated with specific GL accounts for inventory, sales, and purchases. By default, transactions for items belonging to the product line update these GL accounts. You can also set up alternate product line accounts when it is necessary to aggregate inventory or sales by site.
- All of the planning programs including product line planning, resource planning, MRP, MPS, and forecasting can be run by product line.
- On sales, purchasing, and service/support management transactions, an item's taxable status defaults from the product line.

▶ See “Alternate Product Line Accounts” on page 25 for details.

MFG/PROeB is a standard cost system, although it can be used as an average cost system. The product line GL accounts are oriented to standard cost accounting. The values for these accounts default from the System/Account Control File (36.1). The accounting department is usually responsible for approving these.

▶ See *User Guide Volume 4A: Financials* for details on the control file.

Product Line Maintenance

Use Product Line Maintenance to define product lines and their associated accounts.

| Inventory Accounts | | | |
|-----------------------|------|----|------|
| Inventory Acct: | 1500 | | 0100 |
| Inv Discrep Acct: | 5900 | 20 | 0100 |
| Scrap Acct: | 5800 | 20 | 0100 |
| Work in Process Acct: | 1600 | 20 | 0100 |
| Method Variance Acct: | 6200 | 20 | 0100 |
| Cost Revalue Acct: | 1550 | 20 | 0100 |

Fig. 2.7
Product Line Maintenance
(1.2.1)

The Taxable and Tax Class fields determine how taxes are usually processed for items belonging to a product line.

GL accounts default from the System/Account Control File. You can accept the default values or enter different account, sub-account, and cost center codes. Sales accounts can be separately defined by site, customer type and channel in Sales Account Maintenance. Inventory accounts can be defined by site and location in Inventory Account Maintenance.

The Default Sub-Account/Cost Center and Override fields let you enter the same sub-account or cost center code for all accounts in a product line. These fields are useful if you use standard account codes, but differentiate product lines with sub-accounts or cost centers.

Product Line Accounts

Table 2.2 lists each product line account, the account type, and typical programs that use the accounts.

Table 2.2
Product Line
Accounts

| | Account | Type | Use |
|---------------------------|------------------------|-------------|------------------------------|
| Inventory Accounts | Inventory | Asset | Inventory Transactions |
| | Inventory Discrepancy | Expense | Inventory Counts |
| | Scrap | Expense | WO Receipt |
| | Work in Process | Asset | Work Orders, Backflush, Rep |
| | Method Variance | Expense | Work Orders, Repetitive, SFC |
| | Cost Revalue | Expense | GL Cost Change |
| Sales Accounts | Sales | Income | Invoice Post |
| | Sales Discount | Expense | Invoice Post |
| | Exempt Sales | Income | Invoice Post |
| | COGS Material | Expense | SO Shipment |
| | COGS Labor | Expense | SO Shipment |
| | COGS Burden (Variable) | Expense | SO Shipment |
| | COGS Overhead (Fixed) | Expense | SO Shipment |
| | COGS Subcontract | Expense | SO Shipment |

| | Account | Type | Use |
|-------------------|----------------------------|-------------|---------------------------------|
| Purchasing | Purchases | Expense | PO Receipt (Non-Inventory) |
| | PO Receipts (Accrued AP) | Liability | PO Receipt, Voucher |
| | Overhead Applied | Expense | PO Receipt |
| | PO Price Variance | Expense | PO Receipt |
| | AP Usage Variance | Expense | Voucher |
| | AP Rate Variance | Expense | Voucher |
| Work Order | Floor Stock | Expense | WO Close |
| | Material Usage Variance | Expense | WO Close |
| | Material Rate Variance | Expense | WO Issue, WO Close |
| | Cost of Production | Expense | Nonproductive Labor |
| | Subcontract Usage Variance | Expense | WO Close |
| | Subcontract Rate Variance | Expense | WO Close |
| Service | Service Labor | Expense | Call/Project Activity Recording |
| | Service Overhead | Expense | Call Activity Recording |
| | Service Expense | Expense | Call/Project Activity Recording |
| | Expense Due | Liability | Invoice Post |
| | Service Returns | Expense | Call Activity Recording |

Alternate Product Line Accounts

In some applications, you may need to set up alternate inventory or sales accounts for the same product line.

For example, you can specify only one inventory account in Product Line Maintenance (1.2.1). If different locations within a site are used for raw materials, WIP, and finished goods, you probably do not want to post inventory transactions for these locations to the same inventory account.

Assign alternate inventory accounts to a product line for a site or site and location using Inventory Account Maintenance (1.2.13). If you want to use the product line account code but modify the sub-account or cost center, specify the new sub-account or cost center in the Default field and set the associated Override field to Yes.

Fig. 2.8
Inventory Account
Maintenance
(1.2.13)

| | | | |
|----------------------|-------|-------------------------|------|
| Product Line: | 1500 | AUTOMOTIVE PRODUCT | |
| Site: | 15000 | San Diego Auto Products | |
| Location: | 666 | Reject/Rework Cage | |
| Default Sub-Account: | S100 | Override: | yes |
| Default Cost Center: | C100 | Override: | yes |
| Inventory Acct: | 1500 | S100 | C100 |
| Scrap Acct: | 5800 | S100 | C100 |
| Inv Discrep Acct: | 5900 | S100 | C100 |
| Cost Revalue Acct: | 1550 | S100 | C100 |

In Sales Account Maintenance (1.2.17), alternate sales accounts can be assigned to a site, site and customer type, site and channel, or site, customer type, and channel. Channel is entered on sales quotes and orders to indicate the distribution channel for a sale.

Fig. 2.9
Sales Account
Maintenance
(1.2.17)

| | | | |
|------------------------|----------|-------------------------|------|
| Product Line: | 1500 | AUTOMOTIVE PRODUCT | |
| Site: | 15000 | San Diego Auto Products | |
| Customer Type: | Channel: | | |
| Default Sub-Account: | S100 | Override: | yes |
| Default Cost Center: | C100 | Override: | yes |
| Sales Acct: | 3000 | S100 | C100 |
| Sales Disc Acct: | 3905 | S100 | C100 |
| COGS Material Acct: | 5050 | S100 | C100 |
| COGS Burden Acct: | 6480 | S100 | C100 |
| COGS Labor Acct: | 6860 | S100 | C100 |
| COGS Overhead Acct: | 6495 | S100 | C100 |
| COGS Subcontract Acct: | 5070 | S100 | C100 |

During transaction entry, the system automatically retrieves and uses alternate inventory accounts. Alternate sales accounts are retrieved and displayed and can be modified if needed.

Sites

The site code identifies a specific warehouse or a group of buildings at the same physical location. The site code in the inventory detail record is a basic unit for inventory control and planning.

Sites are assigned to a specific GL entity and database. Some programs, such as MRP, work vertically within single sites. Others, such as distribution requirements planning (DRP) and consolidated order processing, work horizontally across two or more sites and possibly two or more databases.

The system uses sites for inventory records, item costing, purchasing, sales quotations, sales orders, forecasting, master scheduling, MRP, and DRP. Not all programs operate by site. For example, departments and work centers are not site specific.

Taxes

To calculate taxes, you must set up a corresponding address code for each site in Company Address Maintenance (2.12). On taxable transactions, the system uses the site address to select the correct line-item tax environment.

◆ See “Company and Site Addresses” on page 274.

Sites and Enterprise Material Transfer (EMT)

If you are using Enterprise Material Transfer (EMT), you must set up sites to support processing of EMT sales orders. EMT lets you automatically translate sales orders into purchase orders and transmit them to suppliers using Electronic Data Interchange (EDI) or EDI ECommerce. EMT also manages and coordinates changes so that sales order and purchase order information is synchronized.

◆ See *User Guide Volume 2: Distribution* for details on EMT.

Multi-level EMT manages orders across multiple levels within an organization. Order changes can be made at the top or bottom of the hierarchy and are then transmitted up or down to the next level.

Two fields in Site Maintenance are directly related to EMT:

- Use the Default Supplier field to associate a default supplier with each ordering site.
- If you are using direct allocations, set External Supplier to Yes.

Sites and Multiple Databases

▶ See *User Guide Volume 5: Supply Chain Management* for information on **DRP**.

Setting up sites for a single company is a very straightforward process. The site entity defaults to the system entity and the database reference is left blank. However, when MFG/PROeB is used to support multiple company operations, several important questions must be resolved:

- How many databases will be used?
- Will consolidated order processing be used?
- Will distribution requirements planning be used?

The answers to these questions are interrelated and require familiarity with a number of other issues. Before answering these questions, be sure to review the rest of this chapter.

Tip
Database connections are set up using programs on the Multiple Database menu (36.6).

For multiple, connected databases such as those used for consolidated order processing or **DRP**, all the site codes in the system must be set up in each database. When you set up the site code, you assign each site to a specific database. When the system looks for information about this site, it looks only in the assigned database.

If there are multiple databases that are functionally independent from each other, as would be the case for consolidated order processing, each database requires only the site codes for its own operations.

Site Security

▶ See *User Guide Volume 9: Manager Functions* for details on security.

System security features let you determine which users and groups of users can perform inventory transactions at a particular site. Set up site security in Site Security Maintenance (36.3.17).

Site security applies to programs that affect inventory data and have a site field as part of the selection criteria. Site security does not affect inquiries, reports, or delete/archive functions. In a multiple-database environment, site security must be defined separately in each database.

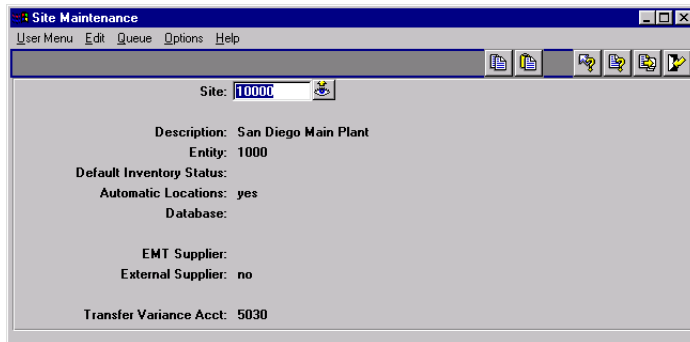

Fig. 2.10
Site Maintenance
(1.1.13)

Site. Enter a unique identifier for a site. Even though consolidated order processing and DRP may not be implemented in the immediate future, it is a good idea to make site codes unique across all databases.

Entity. Entity codes differentiate GL transactions for separate companies or businesses. The entity code assigned to the site determines the GL entity for transactions created when inventory is moved into or out of it.

When the operations for a single company (entity) are controlled within one database, the system entity, the GL entity defined as the primary entity, and the site entities should be identical. This remains true in each operating database, even if multiple databases are used for consolidated order processing or distribution requirements planning.

Default Inventory Status. Enter a status code to associate by default with items at this site.

▶ See page 32 for details.

Automatic Locations. Set to Yes if you want the system to create new locations whenever an undefined value is entered in an inventory transaction.

▶ See “Automatic Locations” on page 31 for details.

You cannot delete a site record that is associated with any of the following:

- Locations
- Inventory quantities
- Item-site planning data
- Open-quantity purchase requisitions

- Purchase orders with an open quantity to receive
- Purchase order receipt history data
- Sales quotes with an open quantity to release
- Sales orders with an open quantity to ship or an invoiced quantity
- Open work orders
- Physical inventory count tags
- Inventory movement security records
- Projects, project activity orders, worksheets, or worksheet detail records created using Project Realization Management (PRM) functions
- Family hierarchies, family-level plans, or end-item operations plans created using Enterprise Operations Plan functions

Locations

A location defines an area such as a shelf, bin, or tank within a site. Since inventory locations are a subset of site, the same location codes can be used for different sites. A site can have an unlimited number of locations. Although the system permits the use of blank location codes, this is not recommended.

Fig. 2.11
Location
Maintenance
(1.1.18)

The screenshot shows a window titled "Location Maintenance" with a menu bar (User Menu, Edit, Queue, Options, Help) and a toolbar. The main area contains the following fields:

| | | |
|-------------------|--------------------------|----------|
| Site: | 10000 | nj plant |
| Location: | 100 | |
| Description: | Raw Materials/Assemblies | |
| Inventory Status: | good | |
| Project: | | Blank |
| Date Created: | 05/27/92 | |
| Permanent: | Yes | |
| Type: | stockrm | |
| Single Item: | No | |
| Single Lot/Ref: | No | |
| Capacity: | 4,000.0 | UM: ea |

▶ See "Setting Up the Inventory Control File" on page 218 for details.

Select a location naming convention that takes advantage of how inventory is detail allocated (picked). When work order and sales order picklists are printed, the system looks through locations for available inventory and makes detail allocations. It searches location codes in

ascending or descending order according to the setting in the Inventory Control File (3.24).

Because of this, numeric location codes such as 1000, 1100, and 8000 are recommended. If you use significant codes and allocate in ascending order, the system allocates inventory in alphabetic order so that Inspect would come before Stores.

Permanent/Temporary Locations

Locations can be defined as permanent or temporary. When you define a location as permanent, the system maintains all location detail records for that site/location until they are deleted using *Zero Balance Delete/Archive* (3.23). Since detail records are maintained, locations with zero balances appear on reports.

If you define a location as temporary, the system automatically deletes inventory detail records when the location's balance falls to zero. It does not delete the location code. Since zero balance locations do not have detail records, they do not appear on reports.

Automatic Locations

The system can automatically create location codes whenever you enter an undefined value. Do this by setting *Automatic Locations* to *Yes* in *Site Maintenance* (1.1.13). This option is useful if you frequently need to define a new location while entering a transaction.

Note The system automatically creates new location codes without verification. This means you can inadvertently create a new location code from a typing error. For example, if you type *STWCK* instead of *STOCK*, the system creates a location code called *STWCK*.

If a site has a complex network of storage locations, automatic locations may be a useful feature. An alternate approach is to set up your main locations in *Location Maintenance* (1.1.18) and define sub-locations using the lot reference field.

Single Item Locations

Some locations can be used to store different types of the same kind of material. For example, a vat may contain any kind of liquid, such as olive oil, ammonia, or acetic acid. However, at any one time, you only want one type of liquid in that location.

Tip
Single item applies to lot reference also, if it is used.

Define these locations as single-item locations by setting Single Item to Yes in Location Maintenance. When a location is designated as a single item location, it can only have an on-hand balance for a single lot of one item at a time.

Location Types

Some items require special storage conditions, such as temperature control or sterile environments. Storing these items in an inappropriate location can cause inventory to become unusable. Location type codes enable you to control the type of inventory stored in a location.

Specify the type code for a location in Location Maintenance (1.1.18). Then, identify the items that require this type of storage by specifying the same type code for the item in Item Inventory Data Maintenance (1.4.5) or Item Master Maintenance (1.4.1).

When an item is received, the system checks the location and item type. If they are not the same, an error displays.

Inventory Status Codes

Use Inventory Status Code Maintenance to create and modify inventory status codes.

- Assign inventory status codes to sites with Site Maintenance (1.1.13) and locations with Location Maintenance (1.1.18).
- Optionally assign default inventory status codes for purchase order or work order receipts to individual items using Item Master Maintenance (1.4.1), Item Inventory Data Maintenance (1.4.5), or Item-Site Inventory Data Maintenance (1.16).

The inventory status code determines whether the inventory balance at a site or location is:

- Nettable for material requirements planning calculations.
- Available for sales order and work order allocations. Allocations are used to reserve inventory and assist in picking inventory to be shipped or issued.
- Issued even if the site or location has a zero or negative inventory balance.
- Not available for particular kinds of inventory transactions. For example, material that is located in scrap locations should not be used for sales order issues.

The screenshot shows a window titled "Inventory Status Code Maint" with a menu bar (User Menu, Edit, Queue, Options, Help) and a toolbar. The main area displays the following information:

Status Code: QC-HOLD

Available: no
Nettable: no
Overissue: no

Restricted Transactions

| Restricted Transaction | CIM Allowed | Description |
|------------------------|-------------|-----------------------|
| ISS-SO | no | Sales Order Shipments |
| ISS-UNP | no | Unplanned Issue |
| ISS-WO | no | WO Issue or Backflush |

Restricted Transaction CIM Allowed Description

| | | |
|--------|----|-----------------------|
| ISS-SO | no | Sales Order Shipments |
|--------|----|-----------------------|

Fig. 2.12
Inventory Status
Code Maintenance
(1.1.1)

You must associate an inventory status code with every site or location you set up. You may want to create a blank inventory status code to use for most situations. This status code should be both nettable and available, with no restricted transactions.

Status Defaults

Each site's inventory status defaults to any locations you add to that site. You can modify inventory status for individual locations as needed.

Item quantities received into inventory are assigned an inventory status based on their associated item master data, inventory detail, or the site or location into which they are received. You can use Inventory Detail

Maintenance (3.1.1) or Detail Maintenance by Item/Lot (3.1.2) to assign a different status to an item's quantity on hand.

▶ See Chapter 5, "Compliance," for information.

If you are using the Compliance module, you can also define inventory attributes, including status, in Work Order Maintenance. These attributes are then used by default during the work order receipt.

You can modify default inventory attributes, including status, during most receipt functions if the receipt location does not already include inventory with different attributes.

Overissue Policy

Whether or not you allow overissues depends on your own policies and procedures. Some organizations determine that to maintain accurate inventory balances, negative balances cannot be permitted.

In an online, interactive system like MFG/PRO eB, inventory records are updated when inventory transactions are processed. Information is sometimes entered in batch when people are not able to enter transactions in real time. Without controls, inventory balances may temporarily be driven negative. However, after all the transactions are entered, inventory balances should not be less than zero.

If all of the following are in place and executed, inventory balances should be accurate:

- Procedures for recording inventory movement
- Procedures for data entry
- Regular cycle counts
- Good stockroom practices such as proper labeling and organization
- Controlled stockroom (that is, people cannot just walk in and take material)

If the Overissue field for the inventory status code is set to No, you may be unable to record a shipment transaction for inventory that is known to have shipped, because a work order receipt has yet to be processed. To prevent unnecessary delays in processing transactions, the Overissue field can be set to Yes. At the end of the day, a report can be run to check for negative balances. Regular cycle counts also help identify problems.

In some regulatory environments, it may be better to set the Overissue field to No. Here, data entry procedures should be developed to ensure the timely entry of inventory transactions. This may be particularly true when there are critical items controlled by lot or serial number.

Note Overissues are not prevented when components are issued during inventory, work order, and repetitive backflush transactions. These transactions assume that component inventory must have been issued if a parent is received or an operation has been completed.

Restricting Transactions

You can use inventory status codes to control and manage how items, sites, and locations are used in the system.

- You can specify whether particular kinds of transactions can occur for individual items. For example, you typically inspect purchased items. Use the PO Receipt Status field in Item Master Maintenance to assign items received on purchase orders a default status that restricts inventory transfers.
- You can determine for sites and locations whether you can initiate particular transactions that affect them. For example, assign a scrap location an inventory status code that restricts issues.
- You can also indicate whether particular transactions can be initiated using CIM-load functions for items, sites, and locations

Not every inventory transaction can be restricted. Some system-generated transactions are required to maintain data integrity. Table 8.2 in Chapter 8, “Inventory Control,” lists inventory transaction types and indicates which ones cannot be restricted.

▶ See “Transaction Types” on page 224.

Some transaction types are not listed in Table 8.2. These transaction types are used exclusively to prevent or allow actions in the system. Since no inventory movement occurs, a transaction history record is not created.

Table 2.3 lists these transaction type codes with a brief description and the name of one of the programs that creates the transaction.

Note Some of these transactions are created in more than one program. In this case, the table simply indicates a typical program associated with the transaction and is not intended to be a complete list.

Table 2.3
Transaction Types
Used to Restrict
Actions

| Transaction Type | Description | Program Creating |
|-------------------------|---|--------------------------------------|
| ADD-FC | Create a forecast for an item. | Forecast Maintenance (22.1) |
| ADD-PO | Add an item to a purchase order. | Purchase Order Maintenance (5.7) |
| ADD-PS | Create a product structure relationship. | Product Structure Maintenance (13.5) |
| ADD-RE | Create a repetitive schedule. | Schedule Maintenance (18.22.2.1) |
| ADD-RMA | Add an item to a return line on a service/support RMA. | RMA Maintenance (11.7.1.1) |
| ADD-SEO | Add an item to a material order. | Material Order Maintenance (11.11.1) |
| ADD-SO | Add an item to a sales order or RMA issue line. | Sales Order Maintenance (7.1.1) |
| ADD-SQ | Add an item to a sales quote. | Sales Quote Maintenance (7.12.1) |
| ADD-WO | Create a work order for an item. | Work Order Maintenance (16.1) |
| INC-PS | Create a product structure relationship by incorporating a PCO. | PCO Incorporation (1.9.7.5) |
| ISS-RMA | Receive an item into inventory on a service/support RMA. | RMA Receipts (11.7.1.13) |

You can also use item status codes, defined with Item Status Code Maintenance (1.1.5), to restrict transactions for an item. Item status codes typically reflect the status of an item in its life cycle from planning through design, production, and obsolescence. In contrast, inventory status codes indicate what can be done with an item based on its physical location or its current use in the system.

CHAPTER 3 Pricing

This chapter discusses the two pricing models used in MFG/PRO eB: best pricing and list/discount table pricing.

Introduction to MFG/PRO eB Pricing **38**

Using Best Pricing **40**

Using List/Discount Table Pricing **78**

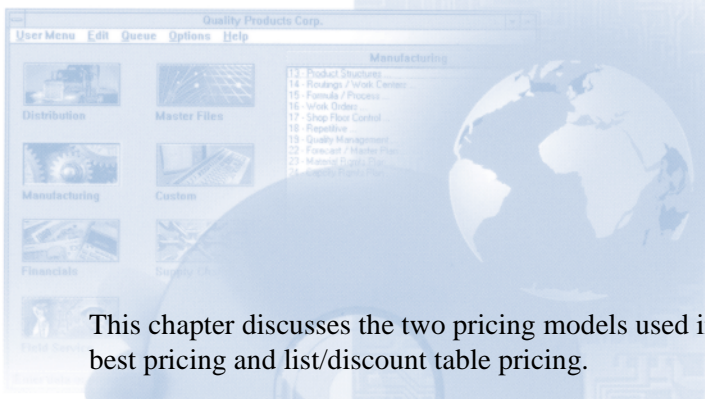

| Routing Maintenance (Date Based) | |
|----------------------------------|----------------------|
| Routing Code: | 10-15000 |
| Operation: | 20 |
| Standard Operation: | |
| Work Center: | 1030 |
| Machines: | INSPECTION, ALL SITE |
| Description: | INSPEC PER PROC-000 |
| Machines per Op: | 1 |
| Overlap Units: | 1 |
| Queue Time: | 1.0 |
| Wait Time: | 0.0 |
| Setup Time: | 0.0 |

Introduction to MFG/PRO eB Pricing

MFG/PRO eB supports automatic pricing in a number of key transactions. The simplest way to establish prices is by associating prices with items in Item Master Maintenance. However, this approach is often too inflexible to meet the needs of modern companies.

For greater flexibility, MFG/PRO eB offers two pricing models based on price lists: best pricing and list/discount table pricing. These models are represented by submenus on the Pricing and Discount menu (1.10).

- Use price lists based on the best pricing model for sales orders, sales quotes, and issue lines on Service/Support Management (SSM) return material authorizations. Set up these price lists in SO/SQ/RMA Issues Pricing Menu (1.10.1).
- Use price lists based on the list/discount table model for automatic pricing of purchase orders, scheduled sales orders, supplier scheduled orders, and SSM returns to suppliers (RTS) and RMA receipt lines. Set up these price lists in PO/RTS/Sched/RMA Rcpt Price Menu (1.10.2)

Table 3.1
Pricing Menus

| | Menu | Menu Label | Program |
|---------------------------|-----------|---------------------------------------|------------|
| Best Pricing Model | 1.10.1 | SO/SQ/RMA Issues Pricing Menu | |
| | 1.10.1.1 | Price List Maintenance | pppimt.p |
| | 1.10.1.2 | Price List Inquiry | pppii01.p |
| | 1.10.1.3 | Price List Report | pppirp01.p |
| | 1.10.1.5 | Price Lists by Customer Inquiry | pppii02.p |
| | 1.10.1.6 | Price Lists by Item Inquiry | pppii03.p |
| | 1.10.1.8 | Price List Copy | pppicp.p |
| | 1.10.1.13 | Pricing What-If Inquiry (S/O) | sopiwiiq.p |
| | 1.10.1.15 | Customer Orders by Price List Inquiry | pppii04.p |
| | 1.10.1.17 | Sales Order Price Inquiry | soppiq.p |
| | 1.10.1.18 | Sales Quote Price Inquiry | sqqpiq.p |
| | 1.10.1.24 | Pricing Control File | pppipm.p |

| | Menu | Menu Label | Program |
|---------------------|----------|----------------------------------|------------|
| List/Discount Model | 1.10.2 | PO/RTS/Sched/RMA Rcpt Price Menu | |
| | 1.10.2.1 | Price List Maintenance | pppcmt.p |
| | 1.10.2.2 | Price List Browse | ppbr003.p |
| | 1.10.2.3 | Price List Report | pppcrp.p |
| | 1.10.2.4 | Price List By Item Report | pppcrp01.p |
| | 1.10.2.5 | Price List Copy | pppccp.p |
| | 1.10.2.6 | Price List Generation By Item | pppcptup.p |
| | 1.10.13 | Volume Discount Maintenance | sosdmt.p |
| | 1.10.14 | Volume Discount Browse | sobr008.p |

Additional pricing functions used in MFG/PRO eB are described in other volumes.

- Service price lists are created in Service/Support Management and used for contract pricing and call billing. They are defined and managed entirely within SSM. ▶ See *User Guide Volume 8A* for details on service pricing.
- Price lists defining default prices and planned costs for items, labor, and expenses used in projects are created in the Project Realization Management (PRM) module. ▶ See *User Guide: Project Realization Management*.
- Advanced Pricing Management (APM) is a separate product that interfaces with sales orders and is used for complex promotional pricing. The features of APM are described in a separate volume. The interface between APM and MFG/PRO eB is described in *External Interface Guide: Advanced Pricing Management*. ▶ See *User Guide: Advanced Pricing Management* for details.

Figure 3.1 illustrates how the system applies the best pricing and list/discount pricing models to various orders in MFG/PRO eB.

Fig. 3.1
Two Pricing
Models

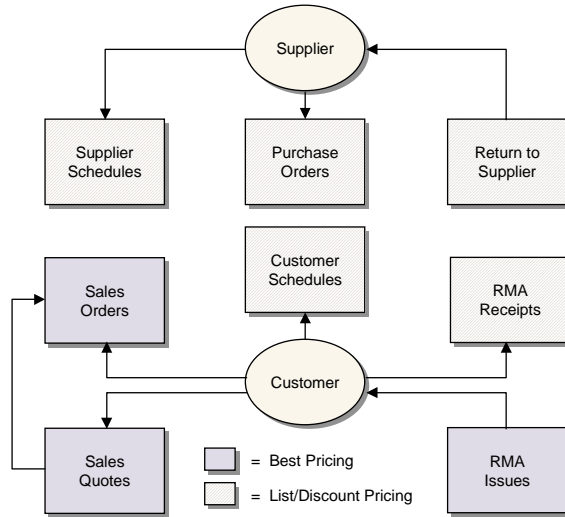

Using Best Pricing

Best pricing, or sales order pricing, enables you to create price lists that accommodate a wide range of pricing situations. Instead of matching price lists strictly through items or product lines, the system can determine best prices using flexible categories of items and customers called *analysis codes*.

Figure 3.2 gives steps for setting up a typical sales order pricing operation. Each step is discussed in detail in the sections that follow.

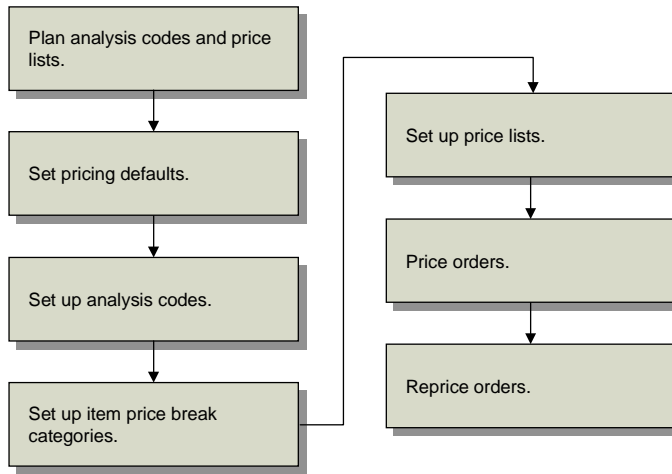

Fig. 3.2
Sales Order Pricing
Work Flow

Sales order pricing includes both the Analysis Code menu (1.8) and the SO/SQ/RMA Issues Pricing menu (1.10.1). Sales order price lists are used to price orders you create in Sales Order Maintenance (7.1.1), Sales Quote Maintenance (7.12.1), and RMA Maintenance (11.7.1.1). Price break categories allow volume price breaks for multiple items. Break categories are assigned to item numbers.

▶ For more information on RMAs, see *User Guide Volume 8B: SSM*.

Planning for Best Pricing

To use best pricing, you need to plan analysis codes and price lists. How you use analysis codes depends on how you organize items and customers. How you use price lists also depends on how you organize items, but also on your product structures, and whether you manufacture configured products, offer discounts on quantity volume, and many other factors.

Planning Analysis Codes

To plan analysis codes, do the following:

- 1 Collect and review your company's current pricing policies, procedures, and associated structures.
- 2 Determine the benefit of using analysis codes with your current or planned pricing practices. Analysis codes are best suited to extensive, complex pricing structures.
- 3 If you decide to use analysis codes, determine how you want to group inventory items and customers in relation to pricing. Establish a list of unique codes identifying these groups.
- 4 For each customer and item group, determine how you want to select members using the conditions available in Analysis Code Selection Maintenance.
- 5 Consider the usefulness of combining analysis codes into hierarchical pricing structures. All attributes of child analysis codes are inherited by the associated parent analysis code.
- 6 Create a visual diagram of how you want to link analysis codes.
- 7 Review and modify all analysis codes defined and determine how they will be associated with one or more price lists.

Planning Price Lists

In planning for price lists, consider the following questions:

- 1 Do you offer promotional discounts?
- 2 Do you engage in joint cooperative marketing agreements with retailers where the amount of cooperative marketing is based on the volume purchased over a period of time by the retailer?
- 3 Do you use coupons?
- 4 Do you convert savings resulting from seasonal fluctuations in materials costs into customer discounts?
- 5 Do you offer additional discounts to customers in a geographical area where a product is not moving quickly?

- 6 Do you maintain a minimum price for a product that is the lowest acceptable price offered, regardless of the number of discounts?
- 7 Do you offer volume discounts based on quantity and/or value?
- 8 Do you negotiate credit terms with your customers?
- 9 Do you negotiate freight terms and freight discounts with your customers?
- 10 Do you want some discounts exclusive of all other discounts or combinable with other discounts?
- 11 Do you want volume discounts based on a range of similar products?

Setting Pricing Defaults

Use the Pricing Control File (1.10.1.24) to set pricing defaults.

Discount Combination Type. Enter either Additive or Cascading to instruct the system what to do when multiple price lists apply.

▶ See “Discount Sequences” on page 58.

Automatic AC Regen for Customers/Items. Enter Yes to have the system automatically add new customers or items to existing analysis codes. Otherwise, enter No. If No, Analysis Code Detail Build must be run after new customers and items are added.

Automatic AC Regen for Edits of Customers/Items. Enter Yes to have the system automatically add modified customers or items to existing analysis codes. Otherwise, enter No. If No, Analysis Code Detail Build must be run after existing customers and items are modified.

QO Default Price Date. Price date indicates which price lists are effective for a quote. Specify a default price date by entering Due Date, Order Date, Required Date, or Promise Date.

Tip
On a sales quote, Order Date is the field labeled Quote Date.

Price QO by Line. Enter Yes to recalculate prices as lines are entered in a quote. This updates prices immediately if a combination of items or quantities qualifies for a better price. Enter No to recalculate prices only once, when the quote is complete.

QO Factor Rounding. The number of decimals to which factors are rounded in a sales quote. The default is 3. This field only has effect when discounts are displayed as factors.

Display QO Discounts as. Valid values are Discounts or Factors. For a 10% discount, the factor is 0.90 (or 1–0.10). The default is Discount. This also controls the format for prompting of a discount.

SO Default Pricing Date. Specify a default price date for sales orders by entering Due Date, Order Date, Required Date, or Promise Date.

Price SO by Line. Enter Yes to recalculate prices as lines are entered in a sales order. Enter No to recalculate prices only once, when the order is complete.

SO Factor Rounding. The number of decimals to which factors are rounded in a sales order. The default is 3.

Display SO Discounts as. Valid values are Discounts or Factors. For a 10% discount, the factor is 0.90 (or 1–0.10). The default is Discount. This also controls the format for prompting of a discount.

Promotions Prefix. If Advanced Pricing Management (APM) is installed, use this field to identify price lists generated by APM.

▶ See *External Interface Guide: Advanced Pricing Management* for details.

Setting Up Analysis Codes

Tip
These codes are not the same as those created in GL Report Writer.

In best pricing, you classify customers and products using analysis codes. Analysis codes are based on characteristics such as region, salesperson, or item number, and can be linked to form combinations or sets. For example, analysis codes can link regions, as shown in Figure 3.3.

Fig. 3.3
Parent and Child Analysis Codes

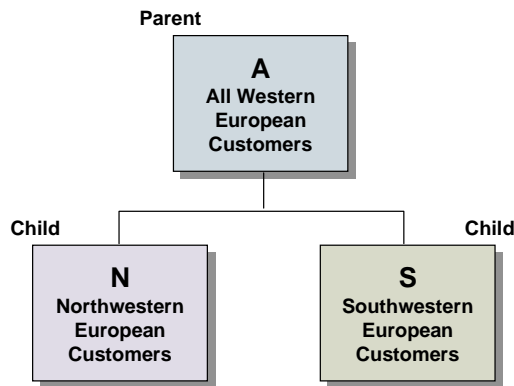

- Analysis Code N groups customers in Northwestern Europe.
- Analysis Code S groups customers in Southwestern Europe.
- Analysis Code A combines the two groups by linking codes N and S.

Code A is referred to as a *parent code* because Codes N and S are linked to it. Codes N and S are referred to as *child codes*.

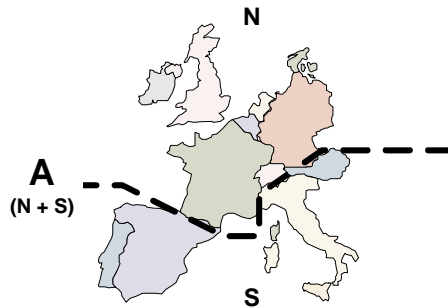

Fig. 3.4
Map of Example Region Codes

Analysis code linking uses OR logic. For example, if code A links codes N and S, any customer meeting the code N or code S criteria is included in code A.

Figure 3.5 outlines commonly used procedures for setting up and managing analysis codes. Each procedure is discussed in detail in the sections that follow.

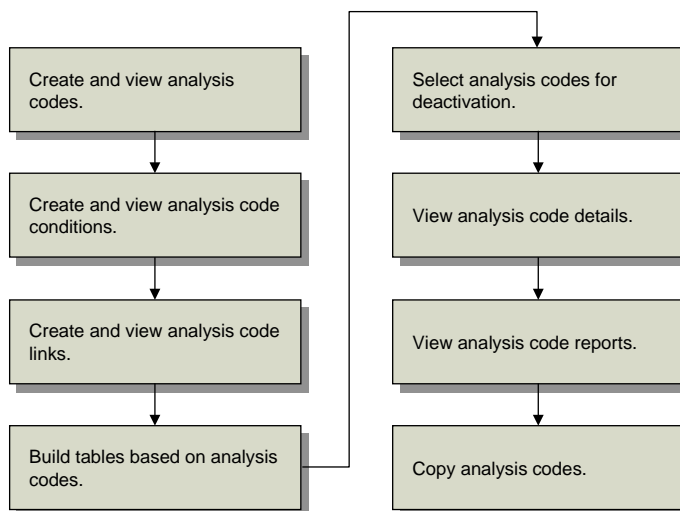

Fig. 3.5
Analysis Code Work Flow

Creating Analysis Codes

Create analysis codes for customers and items in Analysis Code Maintenance (1.8.1). Use Analysis Code Inquiry (1.8.2) to view analysis codes.

Fig. 3.6
Analysis Code
Maintenance
(1.8.1)

The screenshot shows a window titled "Analysis Code Maintenance" with a menu bar containing "User Menu", "Edit", "Queue", "Options", and "Help". The main area contains the following fields:

| | |
|--------------|--------------------------|
| Type: | Customer |
| Code: | OEM |
| Description: | Original Equipment Manuf |
| Active: | yes |
| Comments: | no |

Type. Valid values are item or customer.

Code. Enter an alphanumeric code identifying a group of customers or items.

Description. Enter a brief description of this particular code. This displays in inquiry screens.

Active. Enter Yes. If No, a warning displays when you create a price list with this analysis code.

Comments. Enter Yes to review or update comments.

Use Analysis Code Report (1.8.17) to view details for a range of analysis codes. Enter the analysis code type, analysis code range, and analysis detail selections to be included on the report.

Creating Analysis Code Conditions

Use Analysis Code Selection Maintenance (1.8.4) to define how members are selected for inclusion in an analysis code group. Use Analysis Code Selection Inquiry (1.8.5) to review analysis codes and their condition fields and ranges.

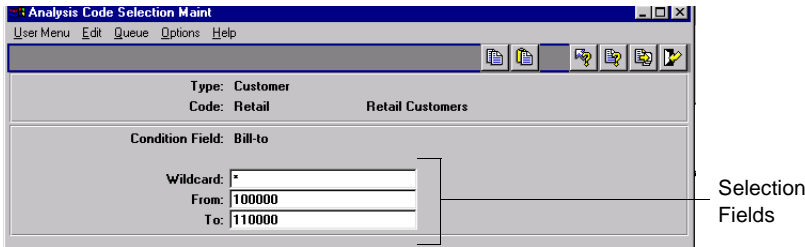

Fig. 3.7
Analysis Code
Selection Maint
(1.8.4)

Type. Valid values are item or customer.

Code. Enter an analysis code you created previously, considered the parent code.

Condition Field. Enter a characteristic or qualifier. You can apply more than one condition to an analysis code. If multiple qualifying conditions are selected, AND logic is used. For example, if Condition Field is set to Salesperson 1, and a second Condition Field is set to Salesperson 2, only records meeting both conditions are selected.

| Customer Conditions | | Item Conditions | |
|---------------------|---------------|-----------------|--------------|
| Bill-to | Salesperson 2 | Article | Item Number |
| Class | Site | Break Category | Product Line |
| List Type | Sort Name | Buyer/Planner | Site |
| Number | Type | Description 1 | Type |
| Region | User Field 1 | Description 2 | User Field 1 |
| Salesperson 1 | User Field 2 | Group | User Field 2 |

Table 3.2
Valid Conditions

Wildcard. Enter one of the following wildcards:

- (.) period—a single position wildcard. For example, .2 indicates any selection with 2 in the second position.
- (*) asterisk—a multiple position wildcard. For example, *2 indicates any item with 2 in the last position.

From. For a condition, enter the beginning range to be included in the analysis code.

To. For a condition, enter the ending range to be included in the analysis code.

Linking Sets of Analysis Codes

By linking analysis codes, you can organize customers and items in a variety of ways. Item analysis codes can be linked only to other item codes, and customer codes only to other customer codes.

Analysis code linking uses OR logic. For example, if code ABC links A, B, and C, any customer meeting the criteria for A, B, or C is included in ABC.

Link analysis codes in Analysis Code Link Maintenance (1.8.7).

Fig. 3.8
Analysis Code Link
Maintenance
(1.8.7)



Type. Valid values are item or customer.

Code. Enter a valid analysis code. This code is considered the parent.

Linked Code. Enter the code you want to link to. This code is considered the child.

Description. Enter a brief description of this link.

You can view analysis code links in two ways.

- Use Analysis Code Link Inquiry (1.8.8) to view codes linked to a parent code.
- Use Analysis Code Where-Linked Inquiry (1.8.9) to view child analysis codes and the parent codes they are linked to.

Building Analysis Codes

Use Analysis Code Detail Build (1.8.19) to build a table of items or customers for each analysis code, based on analysis code rules and links previously defined. Build analysis codes whenever these rules or links are changed, when new codes are created, and when new items and customers are created.

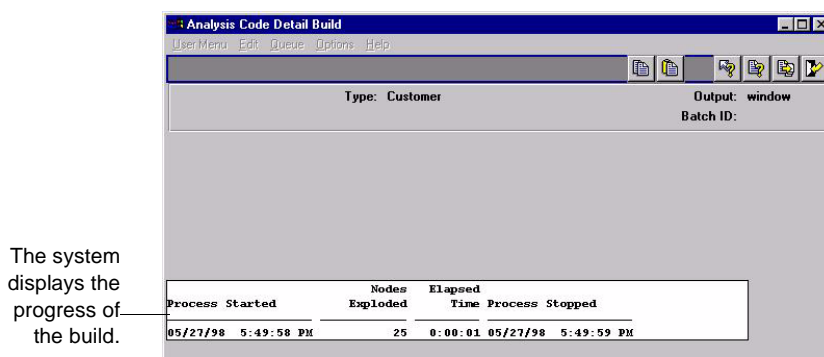

Fig. 3.9
Analysis Code
Detail Build
(1.8.19)

The Pricing Control File (1.10.1.24) gives you the option to automatically build analysis codes when you add new customers and items or make changes to existing customer and item records. However, if you change condition fields for an analysis code, you must still run the build program. This utility builds the database by analysis code type.

Warning Interrupting this utility can disable price lists that use analysis codes. This utility must be completed in its entirety.

As the build proceeds, the system displays:

- *Process Started.* Date and time the program was initiated.
- *Nodes Exploded.* Current number of items or customers processed.
- *Elapsed Time.* Time it took for the system to update each item or code.
- *Process Stopped.* Time the program completed.

At the end of the build, the system generates a summary report, listing the analysis code type, code value, active status, and each customer or item selected by the build.

Detailed Selection of Analysis Code Nodes

Use Analysis Code Detail Maintenance (1.8.13) to inactivate or reactivate individual items and customers selected for a code. An asterisk in the Sel field indicates an active node. Use the Up and Down arrows to position the cursor on the item or customer you want to modify. Then press Enter to toggle its current state.

Tip
Although builds can be run online, batch mode may be more efficient due to potentially long run times.

Fig. 3.10
Analysis Code
Detail Maintenance
(1.8.13)



To select a node by name, press Go to access the update frame at the bottom of the screen. You can type the first character of the node name to go directly to its location in the list of nodes.

Viewing Analysis Code Nodes

There are two inquiries for viewing analysis code nodes:

- Use Analysis Code Detail Inquiry (1.8.14) to view specified analysis codes and their nodes.
- Use Analysis Code Where-Used Inquiry (1.8.15) to view the analysis codes to which a specified node belongs.

Copying Analysis Codes

Use Analysis Code Copy (1.8.20) to copy an existing analysis code as a basis for creating a new one.

Fig. 3.11
Analysis Code
Copy (1.8.20)

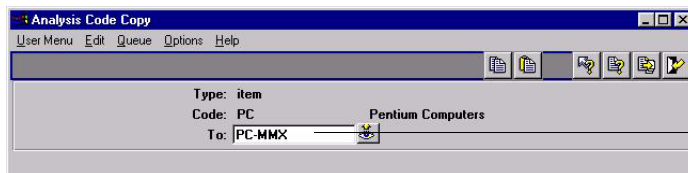

Enter the new analysis code name here.

Type. Enter Customer or Item.

Code. Enter the analysis code to be copied.

To. Enter the name of the new analysis code.

Setting Up Item Price Break Categories

Price break categories let you assign volume price breaks for multiple items. Discounts can be calculated based on the quantity or amount ordered on multiple lines of a sales order or quote.

Example One hundred green bicycles are ordered on line 1 of a sales order, 100 red bicycles on line 2, and 200 bicycle reflectors on line 3. The reflectors receive a price break based on the quantity of bicycles ordered (200)—not the quantity of bicycles plus reflectors (400). The bicycles also receive a price break based on the number of bicycles ordered (200).

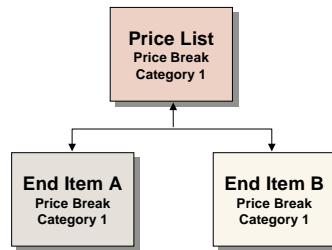

Fig. 3.12
Cumulative Price
Break Categories

There are two ways to take advantage of price break categories:

- Accumulate quantities on related items by assigning the same price break category to each item.
- Offer discounts on accessory items by assigning a price break category to a price list to which the accessory item belongs and to the item master of the accessory item’s principal item.

In the case illustrated in Figure 3.13, bicycle tire pumps belonging to the price break category *Accessories* qualify for Price List A. Price List A uses the price break category *Bicycles* to determine the price for the pumps, even though the pumps do not belong to that price break category.

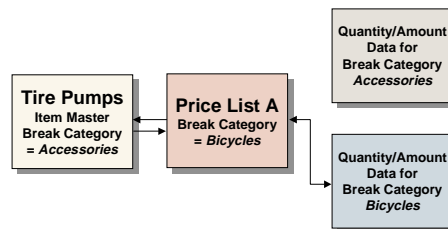

Fig. 3.13
Price Break
Categories and
Accessory Items

Enter break categories in Item Master Maintenance (1.4.1) and Price List Maintenance (1.10.1.1).

Fig. 3.14
Price Break Cat
Field of Item
Master
Maintenance
(1.4.1)

The screenshot shows the 'Item Master Maintenance' window. The 'Price Break Cat' field is highlighted with a red box and labeled 'Price Break Cat field'.

Item Number. Enter an item code.

Price Break Cat. Enter a category name. Name price break categories as you like, but make sure that you enter the same names on price lists and other items.

Creating and Maintaining Price Lists

A price list defines all the information necessary to correctly price an item for a customer. A price list applies to the customer or item codes you assign to it as follows:

- A single item number
- A single customer number
- A group of customers belonging to an analysis code
- A group of items belonging to an analysis code
- All customers

▶ See “Discount Types” on page 53.

The discount type, referred to as the *amount type*, defines the purpose of a price list. There are several discount types, and they can be combined. A price list also defines minimum quantities, effective dates, and other information you may want to extend to your customers.

▶ See “Calculating Best Prices” on page 56.

When an order is entered, the system determines which price lists apply, examines those lists, and determines which of them yield the best price for the order. Applicable price lists may have been determined using the same or different criteria.

Discount Types

The Amount Type field determines the discount type assigned to a price list. Possible choices are:

- *List Price*. Used as the item list price. List prices also set allowable minimum and maximum prices, if selected for a given line item, even if the list price is manually overridden.

List prices are the foundation of pricing logic. The choice of exclusive, base, combinable, and base combinable as the Comb Type does not apply to list prices. They must be set up with a Comb Type of combinable.

- *Discount%*. Percentage subtracted from the item list price.
- *Discount Amt*. Amount subtracted from the item list price.
- *Markup*. Percentages added to item cost in a specified cost set. Must be either a base or exclusive combinable type.
- *Net Price*. Discounts resulting in a fixed price. Must be either a base or exclusive combinable type.
- *Accrual*. Similar to Discount%, except that a percentage of the net price accrues to a specified general ledger account, without reducing the net price, and independent of discount.
- *Credit Terms*. Specified for an order or quote, independent of other discount types.
- *Freight List*. Specified for an individual order or quote line item, independent of discount.
- *Freight Terms*. Specified for an order or quote, independent of discount.

Other Pricing Elements

The system processes pricing by line item. As a sales order or quote is entered, the system determines the following:

- Who the pricing customer is.
- Which price lists combine with other price lists.
- Which price lists are candidates for each line item.
- Whether break category discounts apply.

- Whether configured products are included, and whether pricing applies across the entire product or at the current level only.
- Which price list yields the best overall price for the customer.

Who Is the Pricing Customer?

When selecting price lists, the system determines who the pricing customer is as follows:

- When sales orders are entered, the system uses the customer number in the Ship-To field as the pricing customer if the ship-to customer exists in the customer master file.
- Otherwise, the system uses the customer number in the Sold-To field as the pricing customer.

Discount Combinability

The best possible new price of a line item is determined by considering multiple discounts and combining various discounts. Combination types instruct the system how price lists combine with other price lists for purposes of multiple discounts and best pricing calculations. The choices are:

- *Base*. The standard discount for customers that serves as the basis for additional discounts and can be combined with any non-exclusive price list. Base price lists are exclusive of other base price lists.
- *Combinable*. Incremental price lists intended to combine with base and other combinable price lists.
- *Base-Combinable*. Incremental price lists intended to combine base price lists only.
- *Exclusive*. Exclusive price lists that cannot be combined with any other price lists.

The best discount the system arrives at is one of the following: best base price plus all combinable discounts, best base price plus the best base combinable price list, and the best exclusive price list.

Markup and net price lists must be of combination type base or exclusive.

List price tables provide pricing history and set minimum/maximum prices. They are the foundation for the pricing logic. For pricing

structures with an Amount Type of list price, the combination type does not apply. They must be set up with a Comb Type of combinable.

Price List Candidates

The system finds candidates by matching the customer number and the item number on a sales order with the customer code and the item code on the price lists. A match is found if *all* of the following conditions are true:

- Customer code on the price list equals:
 - The customer entered on the order
 - Any customer analysis code associated with this customer
 - Blank, indicating the price list applies to all customers
- Item code on the price list equals:
 - The item number entered on the order
 - Any item analysis code associated with this item number
 - Blank, indicating the price list applies to all items
- The order currency and price list currency are the same.
- The start and end dates are effective.

Break Categories and Price List Processing

As each line item is priced, the system determines if any lines need to be accumulated for price breaks. If so, the price calculated is based on the total quantity (or amount) on all qualifying line items.

A line qualifies if the item break category matches:

- The break category on a selected price list, *and*
- The break category of another line item on the same order.

Once all line items are completed, the system reviews them to ensure that proper discounts are calculated. For example, if line item 4 affects the quantity discount for a prior line, the system reviews that line and updates its pricing. There may be times when an item should receive a discount based on the quantity ordered on other line items, but should not add to the total break quantity.

▶ See “Other Pricing Elements” on page 53.

Configured Products Pricing

The system determines in two stages whether price lists apply across an entire configured product line or at the current level only.

Factor contestants. Each component, including the parent item of the configured product, is priced independently and then totaled.

Best overall price. The system calculates the net price for the entire configured item, using the rolled-up list price, discounted by only those discounts that apply across the entire configuration.

The system then compares the net price with the best overall net price and chooses the better of the two.

Calculating Best Prices

In best pricing, multiple discounts are considered and applicable discounts combined to determine the best possible net price for a line item, as illustrated in Figure 3.15.

Fig. 3.15
How Best Pricing Works

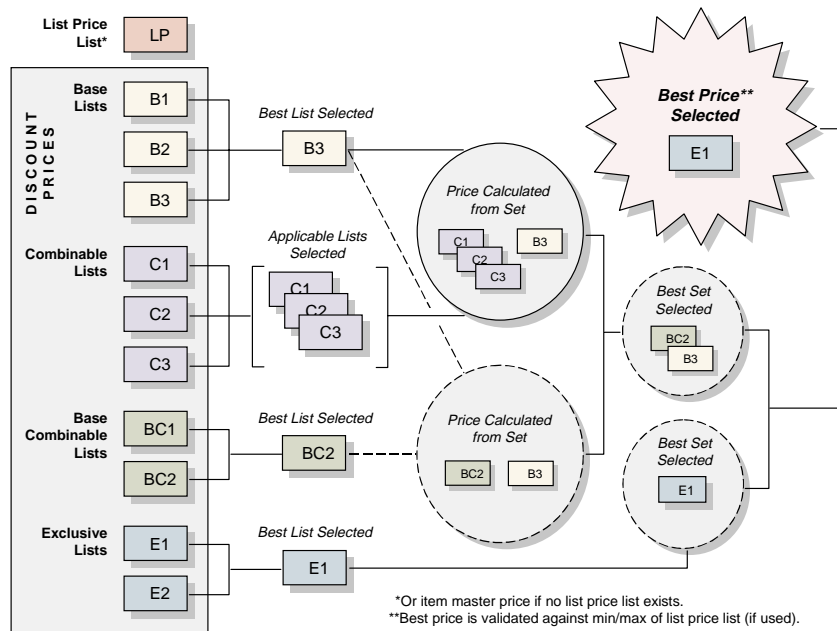

Multiple price lists may apply. The best discount is:

- The best base price plus all combinable discounts, *or*
- The best base price plus the best base-combinable price list, *or*
- The best exclusive price list.

When the system has found all qualifying price lists, it then determines what combinations result in the best price. The rules for combining price lists are based on the Comb Type field in Price List Maintenance.

Table 3.3 lists how the system uses price lists.

Table 3.3
How Price Lists
Are Used

| System Function | What happens |
|--|--|
| Building the Best List Price | The system evaluates each applicable List Price price list. If more than one is found, the lowest price is used. If no List Price list is found, the Price field from the Item Master File is used. The price is stored in the List Price field of the sales order or quote. |
| Building the Best Net Price | The system accesses each applicable Discount%, Discount Amt, Markup, and Net Price price list. It then determines what combination yields the lowest price. The rules for combining price lists are based on the Com Type field in Price List Maintenance. The Discount and Net Price fields are then updated on the sales order or quote. |
| Modifying Price for Minimum or Maximum | If the calculated Net Price on a sales order is above the maximum or below the minimum price (set on List Price price lists in Price List Maintenance), the Net Price on the sales order or quote is adjusted. |
| Manually Overriding Calculated Prices | The calculated List Price, Discount, and Net Price can be manually changed on a sales order or quote (if you have password access to these fields). When this occurs, the system records a Manual discount, which is the difference between the system-generated price and the price entered. |

Example A company offers a promotional discount to customers in a geographic area. For qualifying customer A, this discount is better than the standard discount. Qualifying customer B, however, qualifies for a better discount than the geographic discount. The system assigns the better discount, so customer B is not penalized for qualifying for the promotion.

Discount Sequences

Tip

A discount is combinable when more than one price list is used to determine net price.

When using combinable type discounts, the discounts can either be added together or multiplied/cascaded. Specify which calculation to use in the Pricing Control File for all orders and price lists.

When the cascading calculation method is chosen and GL accounts are used to track discounts to individual price lists, the discount sequence number becomes important. This is because the individual discount amounts can differ depending on the order in which they are applied. The net price of the order is the same regardless of sequence numbering.

When the additive calculation method is used, discount sequence number is not significant. With this method, the calculation uses the best list price with each discount and adds the individual discount amounts to obtain the total discount.

Applying the Additive Method

In a sales order line with a best list price of \$100, price lists A and B are used. Price list A has a sequence number of 100 with a 20% discount. Price list B has a sequence number of 200 with a 30% discount. Using the additive method, the system calculates the discounts as follows:

$$\$100 \times .20 = \$20$$

$$\$100 \times .30 = \$30$$

$$\$20 + \$30 = \$50$$

A discount of \$20 is recorded for price list A and \$30 for B. The total discount is \$50 and the net price is \$50. It does not matter which discount is calculated first, because the best list price is used to calculate both individual discounts.

Applying the Cascading Method

Using the cascading method for the same example, the system first performs the calculations for price list A, since it has the lower sequence number:

$$\$100 - [\$100 \times (1-.20)] = \$20$$

$$\$100 - \$20 = \$80$$

Calculations are then performed for price list B:

$$\$80 - [\$80 \times (1-.30)] = \$24$$

$$\$80 - \$24 = \$56$$

The total discount for the order is \$44 and the net price is \$56. For this order line, a discount of \$20 is posted in the general ledger for price list A, and \$24 for B.

If the sequence numbers are reversed, calculations are first performed for price list B:

$$\$100 - [\$100 \times (1-.30)] = \$30$$

$$\$100 - \$30 = \$70$$

Calculations are then performed for price list A:

$$\$70 - [\$70 \times (1-.20)] = \$14$$

$$\$70 - \$14 = \$56$$

As before, the total discount is \$44, and the net price is \$56. But the discount posted for price list A has changed from \$20 to \$14; and the discount for price list B has changed from \$24 to \$30.

When Discount Sequence Numbers Are the Same

It is possible for two or more price lists to have the same sequence numbers. In this case, the discount is proportioned between the two lists according to the contribution of each. The calculation involved for each price list is as follows:

$$(1 - \text{individual discount factor}) / \text{total additive discount} \times \text{list price} - (\text{list price} \times \text{total cascading factor})$$

The discount factor = 1 – discount percent. Following the previous example, the discount calculation for price list A would be:

$$\text{Discount factor} = 1 - .20 = .8$$

$$\text{Discount} = (1 - .8) / .5 \times \{ \$100 - [\$100 \times (.7 \times .8)] \} = \$17.60$$

The individual discount for price list B would be:

$$\text{Discount factor} = 1 - .3 = .7$$

$$\text{Discount} = (1 - .7) / .5 \times \{ \$100 - [\$100 \times (.7 \times .8)] \} = \$26.40$$

Tip

If a manual price list is included in the pricing determination, the system assigns it sequence 999. This ensures that manual discounts are calculated last when the cascading method is used.

▶ See “Applying the Additive Method” on page 58.

The discount calculation works the same with a negative discount.

Creating a Price List

Use Price List Maintenance (1.10.1.1) to define item codes, customer codes, discounts, and other information pertaining to a price list. Create as many price lists as you need to satisfy your pricing requirements. If you do not use price lists, the system uses the Price field in the item master file.

Fig. 3.16
Price List
Maintenance
(1.10.1.1)

The screenshot shows the 'Price List Maintenance' window with the following data entered:

- Price List: PR-0001
- Customer/Analysis Code: D200
- Item/Analysis Code: All
- Currency: USD
- UM: ea
- Start: (blank)
- Expire: (blank)
- Description: (blank)
- Amount Type: List Price
- Qty Type: Quantity
- Comb Type: Combinable
- Min Net Ord: 0.00
- Max Qty: 0.0
- Break Cat: (blank)
- Config Disc: no
- Manual: no
- Max Orders: 0
- Disc Sequence: 10.0
- Print: yes
- Promotion Type: (blank)
- Promotion: (blank)
- Cost Set: (blank)
- Comments: no

Price List. Enter a code identifying the price list.

Customer/Analysis Code. Enter a customer address code, analysis code, or leave blank for all customers.

Item/Analysis Code. Enter an item number, analysis code, or leave blank for all items.

Currency. Enter the code indicating the currency for this price list. The default is the base currency.

UM. Enter a unit of measure or leave blank for all units of measure.

Start. The first day this price list is effective. If left blank, the price list is effective for any date prior to the expiration date.

Expire. The last day this price list is effective. The date must be greater than or equal to the start date. If left blank, this implies no expiration.

Proceed to the next frame.

Description. The description of your price list (optional).

Amount Type. The choices are Accrual, Credit Terms, Discount%, Discount Amt, Freight List, Freight Terms, List Price, Markup, and Net Price. The amount type of the list affects which fields display in the following frames.

▶ See “Discount Types” on page 53.

Qty Type. Specify whether quantity breaks are calculated by Amount or Quantity:

- Amount: Price breaks are based on the total extended list price of items ordered, measured in the price list currency.
- Quantity: Price breaks are determined by the number of items ordered.

Comb Type. This field describes how price lists combine with other price lists for multiple discount and best pricing calculations. Valid values are:

▶ See “Discount Combinability” on page 54 for details.

- Exclusive. Cannot combine with any other price list.
- Base. Can combine with any price list that is not exclusive or another base.
- Combinable. Identifies an incremental price list that is intended to combine with other combinable and base price lists. List price tables must be combinable.
- Base-Combinable. Identifies an incremental price list that is intended to combine only with base price lists.

Tip
Markup and net price lists must be of combination type base or exclusive.

Min Net Order. In conjunction with Qty Type specified, either the minimum order item quantity or minimum order currency amount required for price list; default is 0 (zero).

Max Qty. In conjunction with Qty Type specified, either the maximum order item quantity or maximum order currency amount allowed for price list; default is 0 (zero).

Break Cat. In conjunction with specified Min Net Ord value, an additional category by which item quantities or currency amounts can accumulate for required price list minimum. Either blank if no Break Category specified, the Item Master file Break Category code

selected for this item, or the Break Category code assigned to another Item Master record; default is blank.

Config Disc. Either Yes or No. Applicable to configured products. If Yes, the price list applies to everything in a configured product, when pricing a configured item (otherwise ignored). If No, it only applies to the specific item.

Manual. Enter Yes if this price list should only be considered during line item pricing when it is specified in the Manual price list field. Enter No if this price list should be considered anytime it applies to the customer or item.

Max Orders. Defines the maximum number of orders that can be priced using this list for a given customer. This field is for reference only. It is normally used with manual price lists, which might, for example, apply only once for a new customer.

Disc Sequence. In conjunction with Comb Type specified, a numerical value indicating the order in which the system applies price list discounts relative to other price list discounts with which it can be combined; default is 10.0. A discount sequence can be decimal.

Print. Enter Yes if the price list should be shown on associated sales order documents and invoices; otherwise, enter No. The default is Yes.

Promotion Type, Promotion. These fields only have values if you are using the interface to Advanced Pricing Management.

Cost Set. Applicable cost basis for markup price lists only. Either blank if standard cost or the selected Item Master file current cost set code; default is blank.

Comments. Enter Yes to review or update remarks related to this price list.

Depending on the amount type of the price list you are editing, the system displays a different frame. Figure 3.17 illustrates the frame that displays when the amount type is Credit Terms, Freight List, or Freight Terms.

Tip
The system applies lower numbers first.

Min Qty: 30.0 Cr Terms: 2-30/60

2% DISC: 1/2 DUE 30/60

Min Qty field

Cr Terms field

Fig. 3.17
Min Qty and Credit
Terms Fields

Min Qty. Enter a quantity or amount. The Min Qty field changes to Min Amt if the Qty Type field is set to amount.

Cr Terms. Choose a credit term. The Cr Terms label changes to Frt Terms or Freight List, depending on your selection in the Amount Type field.

Continue entering values for each quantity or amount break.

The frames illustrated in Figure 3.18 and Figure 3.19 display when amount type is Accrual, Discount%, Discount Amt, Markup, or Net Price.

Account and Project fields

Discount

Acct: 3900 [] [] []

Project: []

Accrual

Acct: 3900 [] []

Project: []

Fig. 3.18
Discount and
Accrual Account
Fields

Discount Acct, Sub-Acct, CC, and Project. For Discount%, Discount Amt, Markup, or Net Price price lists, enter an account code for tracking discount amounts. Sub-account, cost center, and project are optional.

For accrual price lists, the label of this field changes to Expense. A percentage of the net price accrues to the account specified in the Accrual Acct field. The Expense account is required and used to balance the credit posted to the Accrual account.

Accrual Acct, Sub-Acct, CC, and Project. These fields apply to accrual price lists only. The account you enter is used to track the accrual amounts in the general ledger.

Proceed to the next frame.

Min Qty. A quantity or amount. The Min Qty field changes to Min Amt if the Qty Type field is set to Amount.

Discount%. A discount percentage. The Discount% label changes to Markup%, Net Price, or Disc Amt, depending on your selection in the Amount Type field.

Fig. 3.19
Min Qty and
Discount% Fields

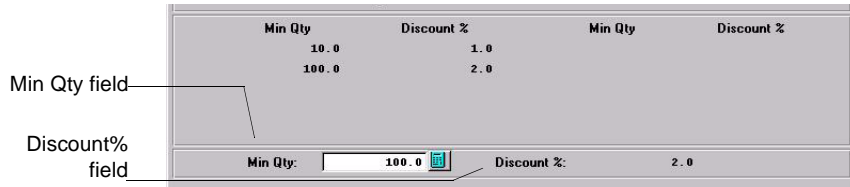

Continue specifying values for each quantity or amount break.

The frame illustrated in Figure 3.20 displays when amount type is List Price.

List Price. Enter the list price for this price list.

Min Price. Enter the lowest allowable price for this price list. If a lower price is entered on a sales order, this price is used instead.

Max Price. Enter the highest allowable price for this price list. If a higher price is entered on a sales order, this price is used instead.

When you create a List Price price list, the following fields are ignored: Qty Type, Comb Type, Min Net Ord, Max Qty, Break Cat, Config Disc, Max Orders, Disc Sequence, Print, and Cost Set.

Fig. 3.20
List Price, Min and
Max Price Fields

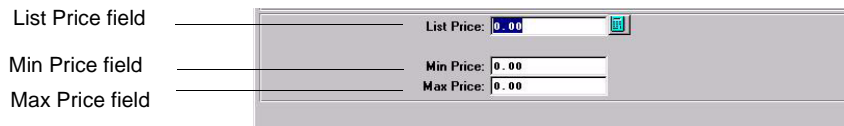

Reviewing Price Lists

To review price lists, use one of the following programs:

- Use Price List Inquiry (1.10.1.2) to review names and summary information on price lists.
- Use Price List Report (1.10.1.3) to review pricing details for each price list.

- Use Price Lists by Customer Inquiry (1.10.1.5) to review price lists sorted by customer code.
- Use Price Lists by Item Inquiry (1.10.1.6) to review price list detail sorted by item code.

Copying a Price List

Use Price List Copy (1.10.1.8) to quickly create new price lists based on existing ones. You can copy a price list into any currency or adjust existing price lists with increased or decreased prices.

The system makes a copy of the source price list under the target price list code with a start date of today. Specific prices (Amount Type List Price or Net Price) are multiplied by the Adjustment Percent and the Cur Conv Factor, then rounded to the specified number of decimal places. Discount and markup percentages are copied as they are in the source price list.

| | |
|---|---------------------------|
| Source Price List: i2ij-1 | Target Price List: i2ij-1 |
| Source Currency: USD UM: | Target Currency: CAD UM: |
| Cust/Supplier Cat: | To: |
| Item Cat: | To: |
| Start: 10/05/98 | Expire: |
| Adjustment %: 100.00% | Curr Conv Factor: 1.75 |
| | Clear Target List: no |
| | Create Target List: yes |
| | Merge Lists: no |
| Round to Two Decimal Places (x.xx): no | Update: no |
| Round to Nearest Whole Number (x.00): no | Print Audit Trail: no |
| Round to Nearest Ten (x0.00): no | |
| Round to Nearest One Hundred (x00.00): no | |
| Round to Nearest One Thousand (x000.00): no | Output: |
| | Batch ID: |

Fig. 3.21
Price List Copy
(1.10.1.8)

Source Price List. Maximum eight-character, alphanumeric code identifying the price list from which the information is copied.

Source Currency. Currency code used by the source price list.

Target Price List. Enter a code identifying the price list to which the information is copied. The target and source price list can be the same. In this case, an ending effective date is added to the source list and a starting effective date to the target list. If the target list is not the

same as the source and does not exist, it can be created. If it does exist, it can be either cleared or added to.

Target Currency. Enter the currency for the system to use on the target prices. The source and target currency can be the same—leave blank for the system to default to the source currency. If you are copying from one currency to another, the system calculates and displays a default Cur Conv Factor using the exchange rates effective on the price list start date. The system adjusts prices on the target list using the conversion factor you specify.

UM. Either an item unit of measure to which price list applies or blank if the price list applies for all units of measure; default is blank.

Cust/Supplier Cat. Either the customer code or the customer analysis code for which price list applies, or blank if price list applies to all customers; default is blank.

Item Cat. Either the item code or the item analysis code for which price list applies, or blank if price list applies for all items; default is blank.

To. Either the last value within a range or blank if range is not specified; default is blank.

Start. Start date defaults to today's date and defines the start date for the new pricing structure created by the copy. This field is applied differently by the system in different situations:

- If the source and target codes and currency are the same and the date entered matches the start date currently on the source price list, a new price list is not created. Instead, the existing price list is modified according to any adjustment percentage entered.
- In other cases when the source and target codes and currency are the same, the system uses the start date as the start effective date on the target list and adds an ending effective date on the source list (day before target's start date).
- If the source and target codes are different, the start date is used on the target and the source list is not affected.

Expire. Either the last date (MM/DD/YY) target price list is effective or blank if price list is effective any date on or after start date; default is blank.

Adjustment%. Percent (up or down) target price list amounts are to be adjusted relative to source price list amounts. Enter 100.0 for no adjustment or a numerical value indicating percent adjustment is needed. For example, 90 adjusts target price list down 10%; 110 adjusts target price list up 10%. The default is 100.0.

Cur Con Factor. Enter a conversion factor to use when the source and target price list currencies are not the same. The system calculates and displays a default Cur Conv Factor using the exchange rate in effect on the price list start date. If effective exchange rates are not found, Cur Conv Factor defaults to 1. You can modify the conversion factor, if needed. However, the value cannot be 0.

Tip
Specify rates in Exchange Rate Maintenance (26.4).

Clear Target List. Enter Yes to delete all other target price lists having same name and attributes or No to not delete other target price lists; default is No.

Create Target List. Enter Yes (the default) to create a new list if one does not exist. When No, a list is not created. If Create Target List is Yes and the list exists, the value of Clear Target List determines if the list is cleared before the copy, or if an end effective date is added to the old prices.

Update. Enter No (the default) and set Print Audit Trail to Yes to print a report of potential changes before they are made. Specify Yes to update price list files based on the parameters specified.

Print Audit Trail. Enter Yes (the default) to print an audit report showing the effect of applying the copy parameters to the target price list. If No, a report does not print.

Output. Enter an output destination for the audit report.

Batch ID. Assigned Batch Identification Number for purposes of processing transaction off line.

Generating Pricing Reports

Three pricing reports display information about how the system calculates prices for order lines:

- Pricing What-If Inquiry (1.10.1.13) displays prices based on user-specified input parameters.
- Customer Orders by Price List Inquiry (1.10.1.15) displays the price lists used to price a customer's orders.
- Sales Order Price Inquiry (1.10.1.17) displays pricing details for selected order lines.
- Use Sales Order Pricing Report (7.15.7) to view pricing history records created for each change to an order line's pricing.

See "Pricing History File" on page 75.

Pricing What-If Inquiry

Use Pricing What-If Inquiry (1.10.1.13) to review what-if pricing scenarios. This inquiry does not apply to configured products with optionally configured components.

Fig. 3.22
Pricing What-If
Inquiry (1.10.1.13)

| Sel List | Amt | Type | Comb | Break | Break Cat | Qty/Amt | Amount |
|-------------|------------|------|------|-------|-----------|---------|--------|
| yes Normall | List Price | Comb | | | | 0.0 Qty | 0.00 |

Customer. Enter the customer address code or customer analysis code for price calculation. Leave blank to calculate prices regardless of customer.

Site. Enter the site code for price calculation. Leave blank to calculate prices regardless of site.

Item Number. Enter the item code or item analysis code for price calculation. Leave blank to calculate prices regardless of item.

Unit of measure. Enter the item unit of measure for price calculation or leave blank if price list applies to all units of measure.

Order Quantity. Enter the number of line items ordered.

Manual. Enter a code identifying a manual price list or leave blank.

Effective. Enter the pricing effective date in MM/DD/YY format. The default is the system date.

Currency. Enter the applicable currency for price list calculations and display. The default is the base currency.

Accumulated Quantity. If price list Qty Type is Quantity, enter the number of items for this order. Either Ord Qty value or Break Qty value; default is Ord Qty.

Accumulated Amount. If price list Qty Type is Amount, the currency amount accumulated for this order. Either Ord Qty x List Price value or Accum Qty x List Price value; default is Ord Qty x List Price.

Show Only Selected. Choose Yes to have the system show only price lists that are selected for use in determining list and net prices. Choose No to have the system show all price lists considered for evaluation of the list and net prices. In either case, a Yes or No appears in the Sel column indicating the system selection process. The default is Yes.

The system calculates the price for the item and customer you selected for each price list that matches the selected item and customer combination.

Viewing Orders by Price List

Use Customer Orders by Price List Inquiry (1.10.1.15) to ensure that a customer does not exceed the maximum number of orders or to see how a price list is used.

| Order | Ord Date | Price Bt | Ln List | Item Number | Qty Ordered UM |
|-------|----------|----------|-----------|-------------|----------------|
| 1013 | 05/28/98 | 05/28/98 | 1 Coolers | 44-100 | 100.0 ER |

Fig. 3.23
Customer Orders
by Price List
Inquiry (1.10.1.15)

Customer. Enter a customer number.

Price List. Enter a price list that applies to this customer. If you want to see all orders for this customer, leave blank.

Open SOs Only. Yes if you want to see open sales orders only. Choose No if you do not want to limit the inquiry.

Viewing Sales Order Discounts

The system calculates and displays price lists, discount factors, net prices, line item amounts, and order amounts online. After line items have been processed, the system recalculates previous lines based upon quantity breaks if subsequent lines result in a different total accumulated order quantity. To view this information, use Sales Order Price Inquiry (1.10.1.17).

Fig. 3.24
Sales Order Price Inquiry (1.10.1.17)

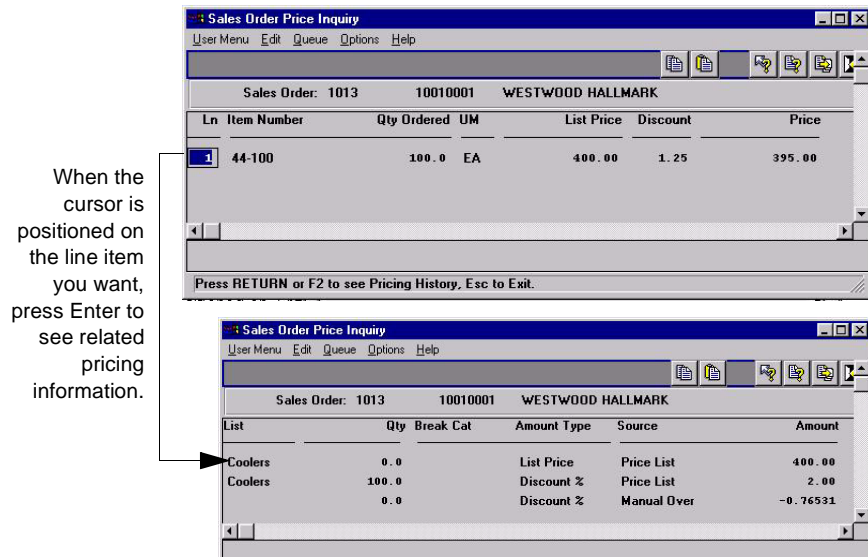

Sales Order. Enter a sales order number, then scroll through the inquiry to display lines on the order. Press Enter on a selected line to see pricing details.

Repricing Orders in Sales Order Repricing

Use Sales Order Repricing (7.1.11) to update the list and net price of selected orders to the latest corresponding price list price. You can reprice sales orders so that ordered quantities are added together, across orders, to calculate quantity breaks.

Sales Order Repricing combines orders by matching price lists and any combination of:

- Sold-to customer numbers
- Bill-to customer numbers
- Ship-to customer numbers
- Purchase order numbers
- Any combination of these four factors

Customers that do not have centralized purchasing can still receive quantity and volume discounts based upon purchases made from other intracompany purchasing departments. Line items on combined orders are repriced as if they are on the same order, which means that line items with the same break category (or the same item number) have their order quantities accumulated.

If you want an open sales order to be repriced in Sales Order Repricing, the Fixed Price field in the sales order header or the line item frame must be set to No. Otherwise, the order is skipped, even if it matches selection criteria.

The Fixed Price field appears in:

- Customer Maintenance
- Sales Quote Maintenance, header and line
- Sales Order Maintenance, header and line
- RMA Maintenance, header and line

Fixed Price defaults from Customer Maintenance to Sales Quote Maintenance, and then to Sales Order Maintenance. If you do not use sales quotes, the value defaults directly from Customer Maintenance to Sales Order Maintenance. The value of Fixed Price on an order header determines the default for each line as it is added.

Tip

To open a sales order for repricing in Sales Order Repricing (7.1.11), set Fixed Price in the order header or line item to No.

When a sales quote is released to an order, the system resets the Fixed Price value on the order header to the value associated with the customer. The line item Fixed Price value is unchanged.

During order repricing, you have the option to:

- Check credit limits after new prices are applied and make various credit adjustments
- Print sales orders
- Combine sales orders
- Include RMA issues
- Recalculate taxes

Use Sales Order Repricing (7.1.11) to reprice and print sales orders and sales quotes for a specified range of order numbers.

Fig. 3.25
Sales Order
Repricing (7.1.11)

| Field | Value | Field | Value |
|--------------------------|----------|-----------------------|----------|
| Sales Order: | 10001 | To: | 10008 |
| Sold-To: | | To: | |
| Bill-To: | 002 | To: | 002 |
| Ship-To: | | To: | |
| Last Price Dt: | | To: | |
| Order Date: | 04/23/00 | To: | 04/24/00 |
| Due Date: | | To: | |
| Check Credit: | yes | Print Sales Order: | yes |
| Set/Clear Action Status: | no | Combine Sales Orders: | no |
| New Action Status: | | Match Sold-To: | |
| Check Credit Hold: | yes | Match Ship-To: | |
| Hold Over Credit Limit: | yes | Match Bill-To: | |
| Check Past Due Invoices: | no | Match P.O.: | |
| Include Sales Orders: | yes | Include RMA Issues: | yes |
| Days: | 30 | Recalculate Taxes: | yes |
| Amount: | 0.00 | Output: | |
| | | Batch ID: | |

Use the Sales Order, Sold-To, Bill-To, and Ship-To fields to narrow the range of sales orders to be processed. Leave blank to include all orders. Use the Last Price Date, Order Date, and Due Date fields to select orders to process by date.

Check Credit. Enter Yes to check customer credit limits and past-due invoices, and generate an audit report. Enter No to bypass credit check and generate audit report only; default is Yes. If Yes, you can change the values of related credit check fields.

Print Sales Order. If Yes, the Print flag is set to Yes on all orders that are repriced. This allows them to be selected for printing even if they have been printed before.

Set/Clear Action Status. If Check Credit is Yes, enter Yes (the default) to check customer credit status prior to release or No to bypass status check. If Yes, the value of New Action Status is assigned to the Action Status field on the sales order for orders exceeding credit limits.

New Action Status. If Set/Clear Action Status is Yes, leave blank to clear the status, Hd to place on hold, or any other valid status code; default is blank. Make sure that codes are entered consistently by entering the allowed codes into Generalized Codes Maintenance (36.2.13) for field so_stat.

Check Credit Hold. If Yes, the system checks the customer Hold flag before clearing the Action Status of an order. If the Hold flag is Yes, indicating the customer is on credit hold, the Action Status of orders is not cleared.

Hold Over Credit Limit. If Yes, the system compares the customer balance to the customer credit limit. The customer balance includes open invoices and, optionally, open sales order amounts. If the customer balance is less than the predefined credit limit and the action status is blank, the order is not placed on hold.

Check Past Due Invoices. Used in combination with Automatically Set Action Status flag. If both are Yes, then sales orders for customer with credit problems are automatically placed on hold by setting the action status flag to the value specified. Otherwise, sales orders are simply listed with all the credit status information

Include Sales Orders. If Yes, the system adds open sales order values to open invoice totals in determining the credit limit. See the description for Hold Over Credit Limit.

Days. The number of days after which the system considers an invoice past due when checking past due invoices.

Amount. The maximum total invoice amount allowed to be overdue after which the system places orders on credit hold for past due invoices.

Combine Sales Orders. If Yes, the system combines sales orders with matching values based on the Yes/No settings in the four Match fields: sold-to, ship-to, bill-to, and purchase order number.

Include RMA Issues. If Yes, the system includes RMA issues in sales order repricing.

Recalculate Taxes. Indicate whether the sales taxes should be recalculated for the sales orders being repriced.

Use Sales Order Price Inquiry (1.10.1.17) or Sales Quote Price Inquiry (1.10.1.18) to verify if items are priced correctly.

Repricing in Sales Order Maintenance

Sales Order Repricing (7.1.11) reprices a range of sales orders at one time. You can also reprice individual sales orders or lines directly in Sales Order Maintenance (7.1.1).

This kind of repricing is controlled with the Reprice field. Reprice always defaults to No in Sales Order Maintenance and cannot be modified for new orders.

On existing orders, enter No to have repricing only occur when requested for a particular line. This protects orders from inadvertent changes and minimizes the number of times pricing history records are updated.

For existing orders, Reprice has several functions in Sales Order Maintenance. When Reprice is Yes for a line:

- You can update List Price, Discount, and Net Price fields during line item entry.
- If prices were determined automatically, the system automatically recalculates the best price for the item, using current data.
- You can review and modify the bill of material for an existing configured line item. If you change the bill, the cost and price are automatically recalculated.
- You can update the discount account, sub-account, cost center, and project for an existing line item.

Table 3.4 summarizes the effect of the Reprice field on sales order lines.

Table 3.4
Reprice Field
Settings and Pricing
Updates

| Modify Sales Order Line | For lines with manual override price | For lines with automatically calculated price |
|--------------------------------|---|---|
| If Reprice = Yes | 1. No automatic calculation. 2. Allow update of price. | 1. Recalculate the best price. 2. Allow update of price. |
| If Reprice = No | No price updating. | No price updating. |

Reprice Field and the Sales Order Header

Reprice works differently in the sales order header than in the sales order line. When Reprice is Yes in the header, Reprice is set to Yes for each line and cannot be changed.

Additionally, setting Reprice to Yes in the header lets all order lines be candidates for repricing, even if only one line item is entered or maintained. This is useful where items are similar, have the same break category, or the same item number.

If Reprice is No in the header, you can still reprice at the line level by setting Reprice to Yes for each relevant line.

Repricing and Manual Prices

If you manually specify a price for a line item, the system does not automatically change this price, even if you request repricing. To manually adjust the price again, set Reprice to Yes for the order or the line item. Then you can update the List Price, Net Price, and Discount fields during order entry.

Although repricing a manually priced line never changes the manual entry, it may adjust discounts based on current information. This processing logic supports posting to the intended discount accounts as identified in price list records. It also enables you to track discount programs in the general ledger.

Pricing History File

The system maintains history records for pricing changes. These records detail the source of each price and discount per order/line. Use Sales Order Pricing Report (7.15.7) to view this information.

Tip
Pricing history documents the source of the current prices only.

Pricing history is also maintained for manually entered prices, and gives a complete record of the source (manual or price list) of each price on file for a sales order. Using this information, the system preserves manually entered prices even when Reprice is Yes.

Pricing history ensures that out-of-balance posting to discount accounts does not occur. When posting discounts to the general ledger, price list history is used, not the difference between list and net, since there can be many discounts, each with different account numbers.

Understanding Sales Order Maintenance Fields

Several fields in Sales Order Maintenance (7.1.1) relate to best pricing.

Fig. 3.26
Pricing Fields in Sales Order Maintenance (7.1.1)

| | | |
|--------------------|---|--|
| Line Pricing field | San Diego CA 92131 United States | San Diego CA 92131 United States |
| Manual field | Order Date: 05/05/98 Required Date: 05/05/98 Promise Date: 05/05/98 Due Date: 05/05/98 Pricing Date: 05/05/98 | Line Pricing: no Manual: <input type="text"/> Site: 15000 Channel: <input type="text"/> Project: <input type="text"/> |
| Fixed Price field | Purchase Order: <input type="text"/> Remarks: <input type="text"/> Entered By: hme | Confirmed: yes 05/05/98 Currency: USD Language: <input type="text"/> Taxable: no Fixed Price: yes Credit Terms: 2/45-60 Credit Terms Int: 0.00 Reprice: no |
| Reprice field | | |

Line Pricing. Affects only newly created orders. On existing orders, it defaults to No and cannot be changed. For new orders, it defaults from Price SO by Line in the Pricing Control File (1.10.1.24). Enter Yes to have the system recalculate price breaks for the order as lines are entered. Enter No to recalculate only once, when order entry is complete.

Manual. Enables you to manually enter a price list code to be considered for order lines. This price list must be set up with Manual set to Yes in Price List Maintenance (1.10.1.1). Manual price lists do not necessarily determine the order line price, but are used in conjunction with other price list search algorithms to determine the best price.

Fixed Price. Sets the default for each line added to the order. Only lines with Fixed Price set to No are updated by Sales Order Repricing

(7.1.11). Defaults from the Fixed Price setting defined for the Sold-To address.

This use of fixed price should not be confused with fixed prices as used in service pricing, which enable the customer to be invoiced for a fixed price regardless of the actual cost of items, labor, and expenses recorded.

Reprice. Enter Yes at the order header to have the system reprice modified line items. The system also reprices other line items belonging to the same break category as a modified item. Otherwise, enter No. If No, you can still reprice line items individually in the order detail pop-up window. If Reprice is No on the order header and you enter a new line, the system automatically reprices it.

Tip
This field only affects the current maintenance session.

Important The value of Fixed Price, not Reprice, determines which orders are repriced by Sales Order Repricing.

| Sales Order Line | | | | | | | |
|------------------|---------------------------------|------------------------------|----------------|----------------------|------------|----------|-----------|
| Line Item | Ln | Item Number | Qty Ordered | UM | List Price | Discount | Net Price |
| Price fields | 1 | 44-100 | 1.0 | EA | 1,000.00 | 0.0 | 1,000.00 |
| Pricing Pop-Up | Description: CONTROL UNIT, HOME | | Sales Acct: | | | | |
| | Location: 12000 | | Site: 10000 | | Disc Acct: | | |
| | Lot/Serial: | | Confirmed: yes | | Project: | | |
| | Qty Allocated: 0.0 | Pricing: 04/01/97 | | Cred Terms Int: 0.00 | | | |
| | Qty Picked: 0.0 | Pricing Date: | | Type: | | | |
| | Qty Shipped: 0.0 | Credit Terms Int: | | UM Conv: 1.0000 | | | |
| | Qty to Invoice: 0.0 | Reprice: | | Consume Fcst: yes | | | |
| | USD Cost: 0.00 | Manual: <input type="text"/> | | Detail Alloc: no | | | |
| | Salesperson[1]: 00000005 | Multiple: no | | Taxable: no | | | |
| | Comm%[1]: 10.00% | Fixed Price: yes | | Comments: no | | | |
| Line Item | | | | | | | |
| Fixed Price | | | | | | | |

Fig. 3.27
Sales Order Line Item Price Fields

Pricing Date. Defaults to the Pricing Date specified on the order header. Used as the effective date in determining prices for this line item. This field is editable if Vary Pricing Date by SO Line in the Sales Order Control File is Yes. Otherwise, the Pricing Date of the order header is used and cannot be changed.

Credit Terms Int. Credit terms interest for this line. Editable only if Vary Pricing Date by SO Line in the Sales Order Control File is Yes.

Reprice. Editable only if Reprice is No in the order header. In this case, you can select individual line items for repricing. When set to Yes for a line, the List Price, Discount, and Net Price fields can be

edited, and if the original price was calculated by the system, it is automatically recalculated.

Manual. Defaults from the Manual field in the sales order header. You can specify a different manual price list for this line, as needed. This field only has effect if Reprice is Yes.

Fixed Price. Initially defaults from the order header, but can be unique for each line. Determines whether this sales order line is considered by Sales Order Repricing (7.1.11) and whether automatic repricing can occur for this line item in Sales Order Maintenance.

Using List/Discount Table Pricing

List/discount table pricing is an alternative to the best pricing model. It is used for pricing different kinds of orders than best pricing, including scheduled orders, purchase orders, returns to suppliers, and receipts in RMA Maintenance.

In this model, prices are defined when an item is set up in the item master. Price lists are used to store other pricing structures, including prices in foreign currencies, prices or discounts for a certain unit of measure such as a case or full truckload, discounts at different quantity levels, or prices calculated as a percentage markup over GL cost.

Price lists and discount tables can be associated with suppliers and customers, and provide defaults for transactions where they are used.

Note Service/Support functions use price lists in a slightly different way. For RMA receipts, the price list is derived from the warranty or contract associated with the item being returned. The RTS, however, is exactly like a purchase order, and derives a price list from the supplier master record.

Four types of price lists can be defined in Price List Maintenance (1.10.2.1):

- Type M. Percent markups or markdowns from item GL cost.
- Type D. Percent discounts from item master price.
- Type P. Fixed discount prices, used primarily for net pricing and foreign currency pricing.
- Type L. Multiple list price tables.

Discount price lists can also be used for quantity-break pricing. During transaction entry, the system looks for one price list when calculating net item price on scheduled orders or RMA returns, and when calculating cost on purchase orders. If an applicable price is not found, either the item master list price is used, or GL cost minus overhead.

Note RMA returns are an exception; if no price is found on the list, the return price defaults to zero.

Use Price List Maintenance (1.10.2.1) to maintain list and discount price tables. During implementation, use Price List Generation by Item (1.10.2.6) to create price tables from existing item master file list prices. Once price lists are created, you can quickly create lists in other currencies using Price List Copy (1.10.2.5).

Creating Price Lists

Each item has a base price expressed in base currency. Price lists are used to store other pricing structures, such as prices in other currencies, prices or discounts for a certain unit of measure (for example, a case or full truckload), discounts at different quantity levels, or prices calculated as a percentage markup over GL cost.

The system looks for a matching price list in the following order:

- 1 Currency, price list, item number, unit of measure
- 2 Currency, price list, item number
- 3 Currency, price list, product line (with item number blank)
- 4 Currency, price list (with product line and item number blank)

If no match is found, the item base price displays, converted to the currency of the order.

Default price lists are derived in different ways, depending on the kind of transaction.

- Purchase Orders: Price lists are associated with suppliers in Supplier Maintenance and provide defaults when purchase orders, blanket orders, and supplier scheduled orders are created.

- Customer Scheduled Orders: Price lists are associated with customers in Customer Maintenance and provide defaults when customer scheduled orders are created.
- Return to Supplier (RTS): These service orders follow the same processing as purchase orders.
- Return Material Authorizations: A credit price list is associated with warranty and contract types. This price list provides the default in RMA Maintenance and is used for RMA receipt line credits.

Only one price structure can be applied to each order. You cannot set up a price list with base prices in a foreign currency and then access another price list to apply quantity discounts to those foreign currency prices.

You can create price lists and discount tables under the same pricing code. If you do, remember to consider the following. If you create minimum or maximum price ranges, you must ensure that they include any range set on the associated discount table. This is because the minimum and maximum prices on price tables take precedence over discount table prices.

Different price structures can be entered for specific units of measure. This enables you to set up discounts so that if, for example, you buy a case (CS), you get a better price than if you buy only one unit (EA).

Total This Level GL Cost and Total GL Cost are display-only fields. The categories whose elements are included are: material, labor, burden, and subcontract. Total GL cost is the total GL cost for the item's default site. It includes all cost elements for this level and lower levels. Total This Level GL Cost is used as the default purchase price. It includes this-level costs, excluding any overhead cost elements. Both purchase and selling prices are for one unit of the item using the item unit of measure.

The screenshot shows the 'Price List Maintenance' window with the following data:

- Price List: 10
- Currency: USD
- Product Line:
- Item Number: 006
- ACA BATCH
- UM: ea
- Start: 01/01/96
- Expire: 12/31/97
- Amount Type: D (P)rice (D)iscount% (M)arkup% (L)ist
- Item Master List Price: 0.00 USD
- Stock UM: KG
- Total This Level GL Cost: 0.00 USD
- Site: 40000
- Total GL Cost: 0.00 USD

| Min Qty | Discount % | Min Qty | Discount % | Min Qty | Discount % |
|---------|------------|---------|------------|---------|------------|
| 1 | 1.0 | 0 | 0.0 | 0 | 0.0 |
| 10 | 20.0 | 0 | 0.0 | 0 | 0.0 |
| 100 | 50.0 | 0 | 0.0 | 0 | 0.0 |
| 1000 | 65.0 | 0 | 0.0 | 0 | 0.0 |
| 0 | 0.0 | 0 | 0.0 | 0 | 0.0 |

Fig. 3.28
Price List
Maintenance
(1.10.2.1)

Price List. Enter a code identifying the price list.

Currency. Specifies the currency of the transactions that are subject to this price list. A price list is used only if the currency of the transaction is the same as the price list currency.

Product Line. Enter the product line associated with this price structure. This field can be left blank. Since each item in the system belongs to a product line, pricing by product line lets you set up price structures for a group of items so that you do not have to enter them individually.

Item Number. Enter an item number if this price applies only to this item. Leave blank to set up price structures by product line or for all items.

Price lists by item are often used to set up foreign currency prices, enabling you to enter a specific base price for an item stated in terms of another currency. This also lets you define different prices at each site. Item prices are also used if you offer special pricing to a customer for only one or a few items, whether specific prices, discounts, or markups.

UM. The unit of measure associated with this price list structure. This field can be left blank if the pricing applies to any unit of measure. Unit of measure is useful for defining special prices based on the unit of measure of the transaction.

Start/Expire. Enter dates if the list should only be considered effective for a defined period of time. If blank, the system considers the prices to be effective indefinitely.

Amount Type (L/P/D/M). Determines whether the price list is a list price table or discount table:

- L: List price table
- P: Discount table (net price)
- D: Discount table (discount %)
- M: Discount table (markup %)

Item Master List Price. Displays the price for one unit of the item, using the item stocking unit of measure, at the item's default site.

Total This Level GL Cost. Displays the total GL cost for the item's default site. It includes all cost elements for this level and lower levels.

Total GL Cost. Displays the default purchase price. It includes this-level costs, excluding any overhead cost elements.

Price Table List Price. Price or cost for one unit of the item, using the price table unit of measure. Overrides the item master list price or cost.

Minimum Price/Maximum Price. A range of acceptable values for the line item net price/cost (list price/cost minus any discounts). If the line item net price/cost is outside this range, the system displays an error message.

Generating Price Lists by Item

After defining item prices in the item master, you can create price tables automatically. Use Price List Generation by Item (1.10.2.6) to create price tables from item master prices. You can create prices for one or a range of items and product lines.

Price List Generation by Item uses only item master list prices, not item cost, to calculate the new list price. It creates only type L price lists, using the default item stocking UM as the price list UM. Once the lists are

created, use Price List Maintenance to add minimum/maximum prices and change prices.

Fig. 3.29
Price List
Generation by Item
(1.10.2.6)

Item Number/To. Enter a range of item numbers for which price tables are to be created.

Prod Line/To. Enter a range of product lines for which price tables are to be created.

Target Price Table. Assign a price list code to the price tables being created.

Target Currency. Assign a currency code to the price tables being created.

Target Start. Assign a start date to the price tables being created.

Target Update Option (S/C/E). Determines how the system handles items that already have a target price list. The default is S.

- Skip: Skips the item and does not create a price table for it.
- Clear: Deletes the existing price table and creates a new one.
- Expire: Sets the expire date of the existing price table to start date minus one day, and creates a new target price table.

Update (Y/N). If No, the system prints a simulated transaction report. If Yes, the system creates the target price tables.

Copying Price Lists

Use Price List Copy (1.10.2.5) to quickly create alternate price lists from one base price list and automatically recalculate prices based on the Cur Conv Factor. You can also adjust existing price lists by increasing or decreasing prices with an adjustment percent.

Fig. 3.30
Price List Copy
(1.10.2.5)

Source Price List. Enter a valid price list code to be used as the source of the data copied to the target price list.

Target Price List. Enter the code to be used as the destination of the copy. Target and source can be the same. In this case, an ending effective date is added to the source list and a starting effective date to the target. If the target list is not the same as the source and does not exist, it can be created. If it does exist, it can be either cleared or added to.

Source Currency. Enter the currency of the prices being copied. Pricing information and currency rate from the source price list are copied to the target price list for the range of item numbers specified.

Target Currency. Enter the currency for the system to use on the target prices. The source and target currency can be the same—leave blank for the system to default to the source currency. If you are copying from one currency to another, the system calculates and a default Cur Conv Factor using the exchange rate effective on the price list start date. The system adjusts prices on the target list using the conversion factor you specify.

Item and To. Enter a range of item numbers to be used as selection criteria in choosing prices to be copied.

Start. Start date defaults to today's date and defines the start date for the new pricing structure created by the copy. This field is applied differently by the system in different situations:

- If the source and target codes and currency are the same and the date entered matches the start date currently on the source price list, a new price list is not created. Instead, the existing price list is modified according to any adjustment percentage entered.
- In other cases where the source and target codes and currency are the same, the system uses the Start Date as the start effective date on the target list and adds an ending effective date on the source list (one day before target's start date).
- If the source and target codes are different, the start date is used on the target and the source list is not affected.

Expire. If specified, the system uses the Expiration date as the end effective date for the target price list.

Adjustment %. Defaults to 100.00%. Specific prices (Amount Type P) are multiplied by the adjustment percent, then rounded to the specified number of decimal places. Discount and markup percentages (Amount Type D and M) are also multiplied by the adjustment percent. If the percentage is greater than 100%, amounts are increased. If the percentage is less than 100%, amounts are decreased.

Cur Conv Factor. Enter a conversion factor to use when the source and target price list currencies are not the same. The system calculates and displays a default Cur Conv Factor using the exchange rate in effect on the price list start date. If effective exchange rates are not found, Cur Conv Factor defaults to 1. you can modify the conversion factor, if needed. However, the value cannot be 0.

Tip
Specify rates in Exchange Rate Maintenance (26.4).

Clear Supplier Price. Determines if the supplier prices are cleared before copying in the new prices.

- If No, prices are added to the existing Supplier Item file.
- If Yes, existing prices in the Supplier Item file are cleared and the new prices are added.

Price List Copy can be used to create supplier-item quotes. When Create Supplier Item is Yes, you are prompted to enter a supplier code. All adjusted prices are calculated and copied into the Supplier Item file as the Quote Cost for that supplier. Quote prices are accessed by purchasing to display the current price quoted by a supplier. Other supplier-item information is also available but must be adjusted manually.

Clear Target List. Defaults to No. Determines if the target price list should be cleared before copying the new prices. If No, adds the prices to the existing target price list. If Yes, clears the target price list first and then copies the new prices.

Update Item Price. Indicates if the item base price should be adjusted during this process.

- If Yes, the item base price in the Item Master File is set to the target price. Two other conditions must be true: the source price list must have a P or L amount type, and the target price list currency must be the base currency. Each item number on the price list is updated with the first price on the price list.
- If No, item base prices are not affected.

Create Supplier Item. Defaults to No and indicates that if the supplier item price does not exist, it should be created. If this is Yes, a new price is created if one does not exist. If this is No, a list is not created. If Create Supplier Item is Yes and the price exists, the value of Clear Supplier Price determines if the price is cleared before the copy, or if an end effective date is added to the old price.

Create Target List. Defaults to Yes and indicates that if the target price list does not exist, it should be created. If this is Yes, a new list is created if one does not exist. If this is No, a list is not created. If Create Target List is Yes and the list exists, the value of Clear Target List determines if the list is cleared before the copy or if an end effective date is added to the old prices.

Round to Two Decimal Places, Round to Nearest Whole Number, Round to Nearest Ten, Round to Nearest One Hundred, Round to Nearest One Thousand (x000.00) (Y/N). Set only one of these to Yes, indicating the rounding method to be used when creating the new price list structure.

Update. Defaults to No. Determines if the target price list is actually updated based on the parameters specified. No is generally specified to create a report of potential changes before they are made. It is recommended that you run Price List Copy first, using the report-only option by setting Update to No and Print Audit Trail to Yes. This lets you review changes before actually creating or updating the target price.

Print Audit Trail. Defaults to No. Indicates if an audit report should be printed. If Yes, a report prints showing the effect of applying the copy parameters to the target price list. If No, a report does not print.

Processing List/Discount Prices

Use list/discount price tables for purchasing, scheduled orders, and some service transactions. The following example shows how they are used on purchase orders, but the process is similar for other transactions.

When entering an order, the Price Tbl and Disc Tbl fields display in the header. These fields record the price table and discount table code for the transaction. Values for both default from the supplier, but you can override them if necessary. Using control file options, you can require users to enter price and discount tables.

To calculate the net cost, the system does two things:

- From the price table, it selects the unit cost for the line item due date or the order entry date, depending on what you specified in the Purchasing Control File. If pricing is by item due date, the due date defaults from the due date in the order header, but you can override it for individual lines from single-line entry mode.
- If a discount table is specified, the system applies the percentage from the discount table for the line or order due date to calculate the extended net cost for the line item quantity. You can override this net cost manually.

If the price table has a minimum and/or maximum cost, the system verifies the calculated or user-entered net price against it. If the net cost is outside the minimum/maximum range, the system displays a warning message and replaces the line item net cost with either the maximum or minimum price from the price table, as appropriate.

Pricing Setup

Settings in two control files affect list/discount pricing:

- Purchasing Control File (5.24) for purchase orders and RTSs
- Sales Order Control File (7.1.24) for customer scheduled orders

Enter appropriate values for the following fields:

Discount Table Required. This flag determines how strictly discount tables are used to control order entry.

- If No, items can be entered whether or not a discount table exists.
- If Yes, only items from an existing discount table can be entered, and only if the price list item, unit of measure, and currency match the order item, unit of measure, and currency exactly.

In searching for a valid price, blank is *not* considered a match. If discount tables are set up with a blank item or unit of measure, a price is never found. If you are pricing by product line rather than item number, this flag should be set to No. Prices can be overridden unless the field is password-protected.

Price Table Required. This flag determines how strictly price lists are used to control order entry.

- If No, items can be entered whether or not a price list exists.
- If Yes, only items from an existing price list can be entered, and only if the price list item, unit of measure, and currency match the order item, unit of measure, and currency exactly.

In searching for a valid price, blank is *not* considered a match. If price lists are set up with a blank item or unit of measure, a price is never found. If you are pricing by product line, this flag should be set to No. Prices can be overridden unless the field is password-protected.

Price by Line Due Date. Specifies whether the system selects the list and discount price based on order date or line item due date.

Product Change Control

MFG/PROeB's Product Change Control (PCC) lets you control and monitor product changes. Approval cycles let you control how and when suggested changes are incorporated into your database.

Introduction **90**

PCR/PCO Life Cycle **93**

Setting Up PCC **96**

Creating PCRs and PCOs **109**

Routing PCRs and PCOs for Approval **122**

Approving PCRs and PCOs **123**

Incorporating PCOs into Production **124**

Closing PCRs and PCOs **129**

Importing and Exporting PCRs and PCOs **130**

Setting Up PCC Security **130**

Introduction

The Product Change Control (PCC) module is a flexible information storage tool that enables you to control and monitor product changes from inception through implementation. With PCC, you can modify item engineering data, product structures, routings, formulas, processes, and item specifications without affecting the files that control activity in your database. You can define an approval cycle for product changes. After approval, changes can be incorporated into the database files that manage product definition.

PCC is built around two types of documents:

- Product change requests (PCRs) record requests for product changes. PCRs only affect your product definitions when incorporated into a product change order (PCO). Typically, they are not strictly controlled. More than one PCR can exist per item.
- Product change orders (PCOs) manage the introduction of changes into your product definitions. PCOs are usually strictly controlled through an approval process. Only one PCO can exist for an item at any one time.

PCRs and PCOs can be used to control changes to most item-related data in a manufacturing environment, including the following:

- Basic item master data maintained in Item Data Maintenance (1.4.3).
- Additions, changes, and removals of product structure and formula records, including alternate BOMs, maintained in Product Structure Maintenance (13.5) and Formula Maintenance (15.5).
- Additions, changes, and removals of product routings and processes maintained in Routing Maintenance (14.13.1), Routing Maintenance (Rate Based) (14.13.2), Process Definition Maintenance (15.13), and Process/Formula Maintenance (15.18).
- Additions, changes, and removals of item specification and test steps developed in Item Specification Maintenance (19.1.13).

A single PCO can affect numerous item numbers, formulas, product structures, routings, processes, or item specifications. New item numbers required by PCOs or PCRs can be added to the database using a screen similar to Item Data Maintenance (1.4.3), accessed from PCR and PCO

Tip
PCC replaces the engineering change order (ECO) programs available from menu 13.13.

Maintenance. The revision number of an item added this way is blank until the PCO adding it is finally implemented.

Add new items needed by a PCR or PCO with an inactive status to ensure they do not appear prematurely on production reports, and are not visible to MRP. While new items are inactive, you can set up additional data, such as inventory, planning, and costing. When implemented, a PCO can change an inactive item's status to active.

Note You cannot maintain item/site data using PCC functions. It is usually better to maintain such data locally by sites. You also cannot use PCC to maintain alternate routings or co/by-product structures.

To use PCRs and PCOs, you first create new production and planning records, or copy existing records into PCRs/PCOs from MFG/PRO eB database files. If you copy records, you can modify them in the PCO and specify the required product changes. These changes do not affect database files used for production and planning until the PCO is approved and incorporated. When this happens, modified records and any new records are copied from the PCO back into the production environment.

Figure 4.1 illustrates the process of copying data into a PCO, making changes, and updating the production files.

Fig. 4.1
PCO Change
Process

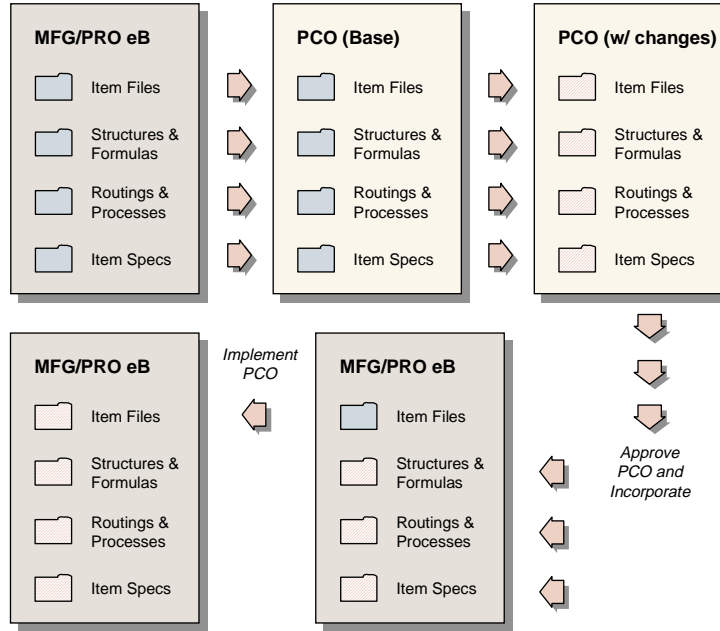

Product changes are copied into MFG/PRO eB production and planning files after an effective date is set for a PCO. The effective date becomes the start date for new records. This way, product changes can be used for planning before the actual effective date arrives and before the records are used for production.

Any changes made by a PCO to item records are copied into master item files in a separate implementation step on the PCO effective date.

PCR/PCO Life Cycle

Figure 4.2 represents the PCR/PCO life cycle.

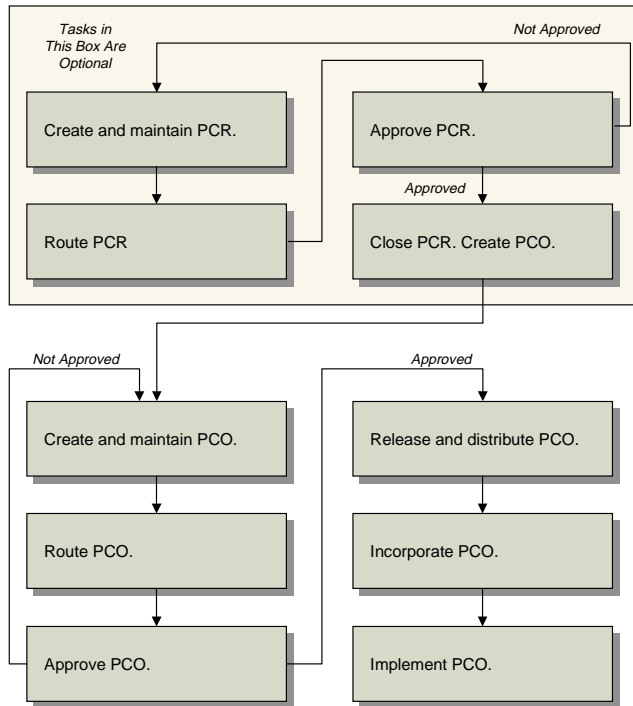

Fig. 4.2
PCR/PCO Life
Cycle

PCR Life Cycle

PCRs can contain the same information as PCOs, but cannot be taken past the approval stage to release. They are useful for companies that receive requests from various sources, such as customers or field representatives, and hold the requests for further processing. You can set up PCC to require a PCR approval process. Once approved, PCRs are typically closed or converted into PCOs. A PCR, approved or not, has no effect on the system until converted into a PCO.

Creating and Maintaining PCRs

Create PCRs in PCR Maintenance (1.9.2.1). Also use PCR Maintenance to capture and modify item, product structure, formula, routing, process, and item specification records. The Type/Design Group combination determines the PCR routing slip and distribution group.

Routing PCRs for Approval

When a PCR is ready for review, comment, and approval, route it using Route PCR for Approval (1.9.2.4). Groups and users who must approve the PCR can be notified with E-mail or printed output that the PCR is ready for review. PCRs that have been routed for approval can be revoked, if necessary, for revision or correction.

Approving PCRs

Use PCR/PCO Approval (1.9.6.1) to monitor the queue of submitted PCRs, add comments, and approve or disapprove each PCR. Disapproved PCRs can be routed back to reviewers for reapproval. The order of approvals is determined by the routing slip attached to each PCR. Once a PCR has been approved electronically by all necessary personnel, it can be closed, or converted into a PCO using PCR Maintenance (1.9.2.1).

PCO Life Cycle

The life cycle of a PCO is more extensive than that of a PCR, since PCOs typically affect production data.

Creating PCOs

Create PCOs in PCO Maintenance (1.9.2.13). Also use PCO Maintenance to capture and modify item, product structure, formula, routing, process, and item specification records. You can also create PCOs by copying or combining existing PCOs or PCRs, or by converting PCRs.

Routing for PCOs for Approval

When a PCO is ready for review, comment, and approval, route it using Route PCO for Approval (1.9.2.16). Groups and users who must approve the PCO can be notified by E-mail or printed output that the PCO is ready for review. PCOs that have been routed for approval can be revoked, if necessary, for revision or correction.

Approving PCOs

Use PCR/PCO Approval (1.9.6.1) to monitor the queue of submitted PCOs, add comments, and approve or reject each PCO. Disapproved PCOs can be routed back to reviewers for reapproval. The order of approvals is determined by the routing slip attached to each PCO. Once the PCO has been approved electronically by all necessary personnel, it is ready to be released.

Release and Distribution

You can release only approved PCOs to manufacturing. Use Release and Distribution (1.9.7.1) to monitor the queue of approved PCOs and choose PCOs to release. If necessary, you can revoke approval of a PCO before release and return it for revision or correction.

Once released and distributed, the PCO can no longer be rejected or modified. Any changes affecting the PCO must be released as separate PCOs. At distribution time, the system automatically generates either hard-copy release notices or E-mail for a defined group of users, either immediately or through batch print queues.

Once a PCO has been officially released, the manufacturing organization is responsible for implementing the changes. Engineering can specify a mandatory date for changes, or allow manufacturing to select a changeover date based on least cost, minimum disruption, or other relevant factors.

Incorporating PCOs

Use Incorporation Planning Report (1.9.7.3) to display inventory levels and monetary values of inventory affected by a PCO. This can help in planning effective dates for changes.

Use Incorporation Selection (1.9.7.4) to monitor and assign effective dates. Then, incorporate it into production using Incorporation (1.9.7.5). You can modify an effective date by incorporating a PCO again with a different date.

Once a PCO is incorporated, MRP uses the effective dates of product changes to plan future orders. However, until the effective date is reached, PCO changes do not affect current operations.

Implementation

When a PCO's effective date has arrived and all changed items, product structures, formulas, routings, processes, and item specifications are in production, use Implementation (1.9.7.13) to move the new item revision numbers and other item data into the corresponding item master files.

Setting Up PCC

To set up PCC:

- 1 Prepare data in other parts of MFG/PRO eB for use with PCC.
- 2 Set up the PCC Control File.
- 3 Define user groups.
- 4 Define approval routings.
- 5 Define document change types.
- 6 Set up PCC security.

▶ See “Setting Up PCC Security” on page 130 for details.

Preparing Data for Use with PCC

To prepare data in other parts of MFG/PROeB for use in PCC, do the following:

- 1 Print existing ECOs, if any, using ECO by ECO Number Report (13.13.3). Implementing PCC disables ECO functions. You print ECOs in order to reenter them as PCOs.
- 2 Determine which manufacturing processes you want to control with PCC, and activate the appropriate sections. There are four possible activation programs:
 - Execute Enable PCC Structure Maintenance (13.13.22). Set Structures to Yes to control product structures. This automatically disables ECO functionality in menu 13.13.
 - Execute Enable PCC Routing Maintenance (14.22). Set Routings to Yes to control product routings.
 - Execute Enable PCC Formula Maintenance (15.22). Set Formulas and Processes to Yes to control formulas and processes.
 - Execute Enable PCC Item Spec Maintenance (19.1.22). Set Item Specifications to Yes to control item specification.

Important Once you enable PCC and thereby disable ECO functions, do not use the ECO functions. Enabling PCC makes changes to your system that cannot be reversed.

- 3 Set up E-mail definitions for your system in E-Mail Definition Maintenance (36.4.20). PCC uses E-mail to contact users during the approval process and life cycle of change documents.
- 4 Create user IDs in User Maintenance (36.3.18). PCC users must be defined before they can be added to groups involved in PCC activities. Assign user passwords, or have users select their own. You can increase PCC security by requiring users to reenter passwords before accessing PCR/PCO Approval.

If you are using E-mail to notify users of PCC activities, make sure that each user has a valid E-mail address and definition.

- 5 Set up printers and batch IDs (36.13.2, 36.14.1, 36.14.3). Users can be notified at various points in the PCC life cycle either by printed reports or E-mail. Batch IDs are useful for running large print jobs

▶ See *User Guide Volume 9: Manager Functions* for information on E-Mail Definition Maintenance.

during off-hours. Also, PCOs can be distributed (1.9.7.1), incorporated (1.9.7.5), and implemented (1.9.7.13) using batch IDs that execute nightly.

- 6 Initialize PCOs in the PCC Control File (1.9.24). The first time you enter the PCC Control File, you are prompted to initialize PCOs to current revision level. Answer Yes to have the system create PCO *000000*, which records current revision numbers for all items in the system. The initial revision numbers serve as a starting point for Item Revision History Browse (1.9.9.6).

Setting Up the PCC Control File

Use the PCC Control File (1.9.24) to specify how PCRs and PCOs are processed.

Fig. 4.3
PCC Control File
(1.9.24)

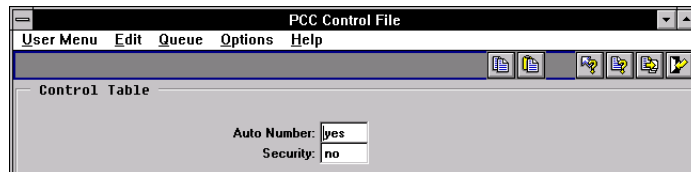

Auto Number. Enter Yes to generate document numbers automatically when a new PCR or PCO is created. Enter No to enter numbers manually when creating PCRs or PCOs.

Security. Enter Yes to verify user identity when PCR/PCO Approval (1.9.6.1) is accessed. If Yes, users are prompted to enter a password before the screen displays. To use this feature, set Security Option in the Security Control File (36.3.24) to U to require a user ID, or to B to require both a password and user ID.

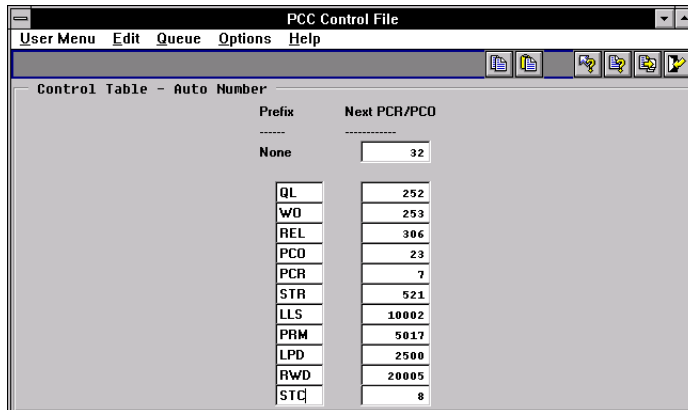

Fig. 4.4
PCC Control File,
Auto Number
Frame

Prefix. If Auto Number is Yes, the system assigns a prefix based on the PCR/PCO Type specified and associates the prefix with the Next PCR/PCO field to create a unique number. Multiple prefixes can be specified. Use the null prefix for types that do not reference a specific prefix.

Next PCR/PCO. The next number available for an associated prefix. When the prefix is used to label a new document, the portion of the number after the prefix is determined by this field.

Tip
Types are defined in PCR/PCO Type Maintenance (1.9.1.9).

Defining Groups, Routing Slips, and Change Types

Three kinds of data are defined in the PCC setup menu: groups, routing slips, and document change types. These three data structures work together to form a model of your company’s product change and approval process.

Figure 4.5 shows how PCC groups, routing slips, and change types are used.

Fig. 4.5
PCC Setup
Functions

Creating Groups

In PCC, groups represent users with different functional responsibilities. Groups are used in three ways:

- Design. Groups designate which users have authority to create and maintain PCRs and PCOs. For example, members of an engineering team might make up one design group. PCRs and PCOs are organized by type and design group, since the design group is the driving force behind change development.
- Distribution. Groups designate which users are notified automatically when a PCO has been released.
- Approval. Groups designate which users have authority to approve PCRs and PCOs.

Use Group Maintenance (1.9.1.1) to define PCC groups.

Fig. 4.6
Group Maintenance
(1.9.1.1)

In the first frame, enter a unique group name and a brief description. Use the second frame to add users to the group, and specify group attributes.

Important Users added to groups must be previously defined with User Maintenance (36.3.18).

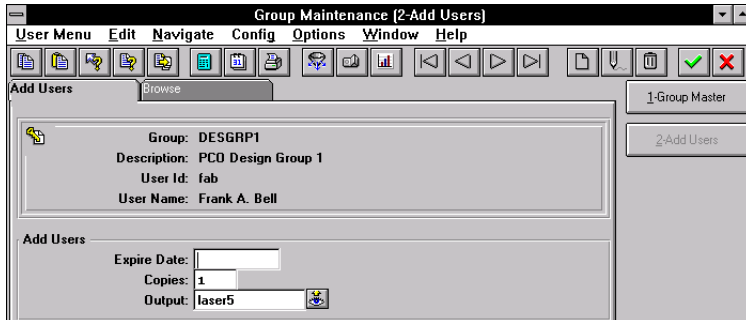

Fig. 4.7
Group Maintenance, Add Users

Expire Date. Optional. Enter a date when the user is no longer considered an active member of the group.

Copies. Enter the number of printed copies to be printed on the printer specified in Output. Enter zero to have the user notified by E-mail.

Output. Typically, the printer on which PCC-related notices are printed.

Tip
Specify the E-mail address in User Maintenance (36.3.18).

Changing Group Memberships

Use Maintain Users in Group (1.9.1.3) to change group memberships. You can add, remove, or replace users, or change user-related settings (Expire Date, Copies, Output). Changes can be made to more than one group at a time, as when a user in several design groups transfers to another department or leaves the company.

Adding Users to Groups

Add users to groups in the Add User frame.

Fig. 4.8
Maintain Users in
Groups (1.9.1.3),
Add User

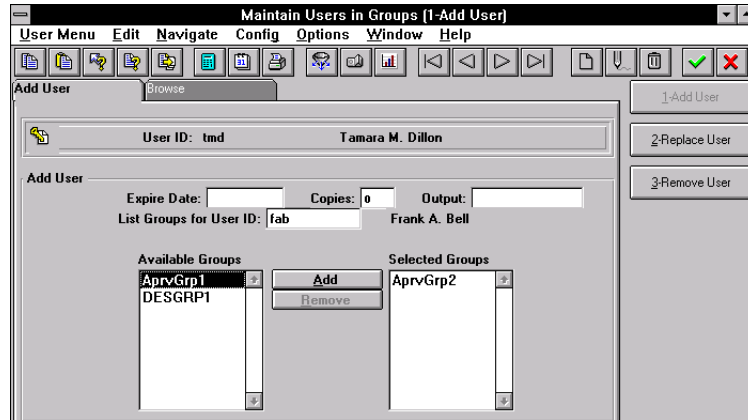

User ID. Enter a valid user ID, previously defined in User Maintenance (36.3.18).

Expire Date, Copies, Output. To modify these user attributes, enter new values.

List Groups. Optional. Specify groups, or leave blank to display all defined PCC groups to which the user being added does not currently belong. Specifying groups can be useful to define one user's membership so that it resembles that of another user.

Available Groups. Select a group to add the user to, and choose Add. Select multiple groups by holding down Shift during selection.

Selected Groups. To deselect a group, highlight it and choose Remove.

Replacing Users in Groups

Replace users in groups in the Replace User frame.

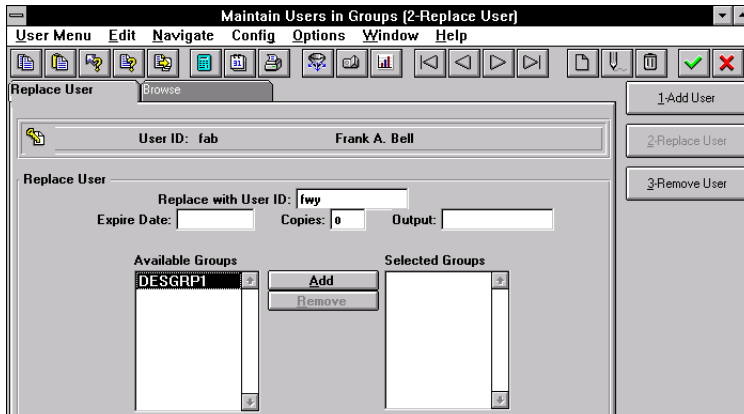

Fig. 4.9
Maintain Users in
Groups, Replace
User

User ID. Enter the user ID of the old user.

Replace with User ID. Enter the user ID of the new user.

Expire Date, Copies, Output. Modify these user attributes as needed.

Available Groups. The list box includes all groups to which the old user belongs. Select a group and choose Add to move it to the Selected Groups list. Select multiple groups by holding down Shift during selection.

Selected Groups. To deselect a group, highlight it and choose Remove.

Tip
You can modify a user's attributes by specifying the same user in both User ID fields.

Removing Users from Groups

Remove users from groups in the Remove User frame.

Fig. 4.10
Maintain Users in
Groups, Remove
User

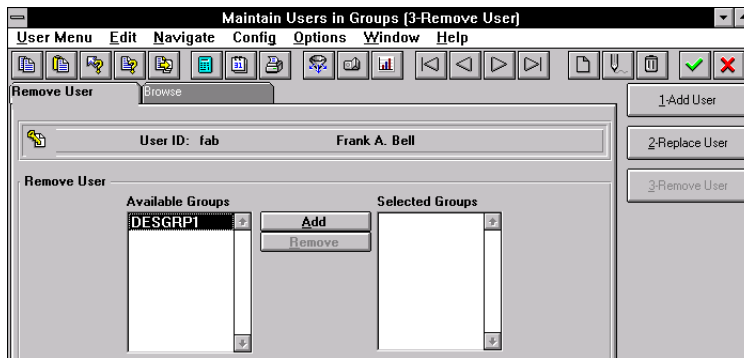

User ID. Enter the user ID of the user being removed.

Available Groups. The list box includes all groups to which the user being removed belongs.

Defining Approval Routings

Approval routings specify who needs to approve a change, and in what order approvals are required. Approval routings are represented by routing slips, which can be created manually or copied from routing templates and modified. Routing slips also indicate who is to be notified when documents are approved. Every PCR and PCO requiring approval must have a routing slip.

Create original routing slips in Routing Slip Maintenance (1.9.1.5), or copy existing routing slip templates and make required modifications. If you modify a routing template, the changes only affect new PCRs and PCOs.

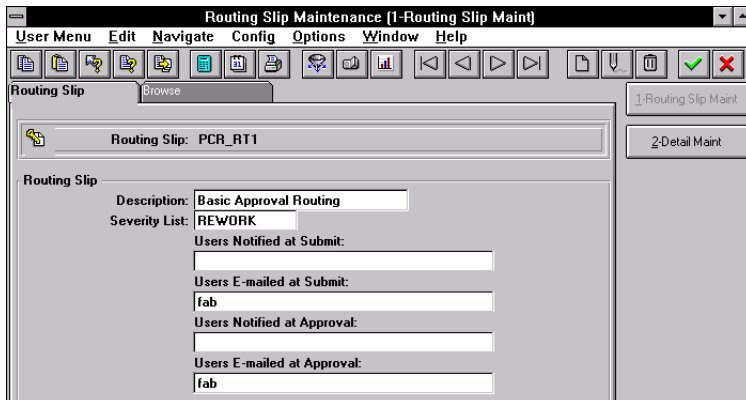

Fig. 4.11
Routing Slip
Maintenance
(1.9.1.5)

Routing Slip. Enter a unique code identifying the routing.

Description. Enter a description of the routing.

Severity List. Enter a code indicating the severity list to be used for this routing. Severity lists are predefined lists of defects, ranked according to how severe each defect is considered. For example, a severity list of hardware defects might appear as follows, with higher numbers being more severe.

| | |
|----|-----------------------------------|
| 5 | Cosmetic/typographical correction |
| 10 | Minor drawing/layout change |
| 20 | Major drawing/layout change |
| 30 | Wrong dimensions |
| 40 | Missing part |

Create severity lists in Reason Codes Maintenance (36.2.17) by defining typical defects and assigning them severity rankings. Group reason codes by a type such as PCC.

When a member of a group with authority to reroute an approval rejects a change in PCR/PCO Approval, a prompt for severity level displays.

Users Notified at Submit or Approval. A routing slip can include a list of users to be notified at the beginning and end of the approval cycle. Users notified must be defined as MFG/PROeB users, but do not have to be members of PCC groups. The system determines the appropriate E-mail address from data specified in User Maintenance.

Tip
Separate multiple
user IDs with
commas.

Tip
Check E-mail addresses carefully to avoid errors. This field cannot be validated.

Users E-Mailed at Submit or Approval. Enter E-mail addresses of persons outside your organization, such as key suppliers, who are to be notified at the beginning and end of an approval cycle. Enter full E-mail addresses, maximum 240 characters. Leave blank to notify only internal personnel.

Enter approval routing details in the Routing Slip Detail frame.

Fig. 4.12
Routing Slip Maintenance, Detail Maint

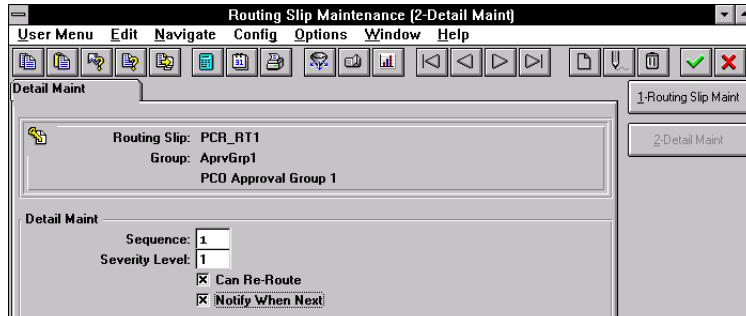

Sequence. Enter a number from 0 to 999 specifying the group’s sign-off position relative to other groups in the routing. If zero, groups can review the document in any order.

Table 4.1 illustrates three types of approval sequences.

Table 4.1
Sample Approval Sequences

| Hierarchical | | Semi-Hierarchical | | Non-Hierarchical | |
|---------------------|----|--------------------------|----|-------------------------|---|
| Engineering | 0 | Engineering | 0 | Engineering | 0 |
| Production | 10 | Production | 0 | Production | 0 |
| QA | 20 | QA | 0 | QA | 0 |
| Finance | 30 | Finance | 10 | Finance | 0 |

When a non-hierarchical order is used, groups can review the document in any order. Skip some sequence numbers to facilitate addition of groups in the future.

When a hierarchical or semi-hierarchical order is used, you can use the Notify When Next flag in combination with the Next Only flag in PCR/PCO Approval to display only those PCOs approved by all subordinate groups.

Severity Level. Enter a number indicating what severity of defect results in PCRs and PCOs being rerouted to this group. Lower numbers mean that minor defects are rerouted to this group. If you are not using severity levels, enter zero.

Tip
The severity level acts as a filter to prevent needless review and streamline the PCO approval process.

The system reroutes a PCO to a group whenever the group in question has approved the change document *and*:

- The change document is rejected by another group on the routing slip that has reroute authority (Can Re-Route is Yes), *and*
- The rejecting group sets the reroute level to a number greater than or equal to the severity level in this field.

Can Re-Route. Enter Yes to indicate that this group has the authority to reroute a PCO when they reject it. To effectively disable rerouting, enter No for all routing slips.

Important Disabling rerouting means that *every* group on a routing slip must reapprove a corrected document.

Notify When Next. Check this box to have the system notify each group when it is next, based on sequence number, in an approval routing. Users to notify should have valid E-mail addresses.

Routing Slip Copy

Create new routing slips based on existing routing slip templates in Routing Slip Copy (1.9.1.7).

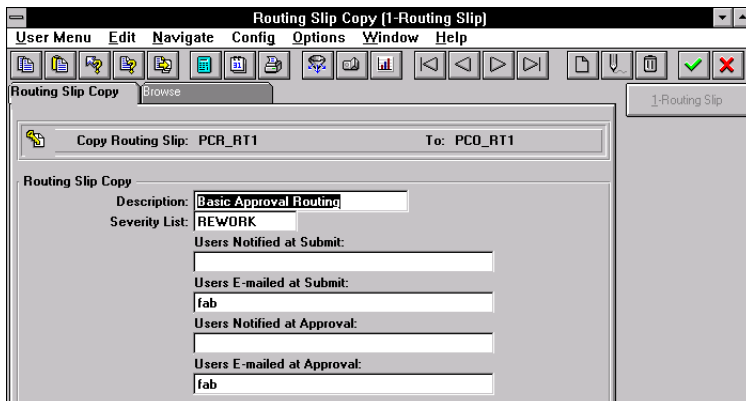

Fig. 4.13
Routing Slip Copy
(1.9.1.7)

The list of users to notify at submission and approval defaults from the source routing and can be modified. When you press Go, you are prompted to copy the routing detail. Respond Yes to have the system copy approval routing details for each group from the source routing to the new routing. If you respond No, groups can still be added later using Routing Maintenance.

Defining Document Change Types

Use PCR/PCO Type Maintenance (1.9.1.9) to set up codes for PCR and PCO types. The type code determines whether the change document is a PCR or a PCO, and determines the routing slip, distribution group, prefix, and number.

Defining document change types requires careful planning. Some criteria to consider are:

- Purposes of the PCO, such as to enhance safety, upgrade functionality, reduce cost
- Product lines affected by the PCO
- Design areas affected by the PCO, such as electrical, mechanical, or pneumatic
- Approvals required for the PCO

Fig. 4.14
PCR/PCO Type
Maintenance
(1.9.1.9)

The screenshot shows a window titled "PCR/PCO Type Maintenance" with a menu bar (User Menu, Edit, Queue, Options, Help) and a toolbar. The main area contains the following fields:

| | |
|----------------|--------------------|
| Type: | PCOTYPE1 |
| Design Group: | DesGrp1 |
| Description: | Basic Change Order |
| Document Type: | PCO |
| Prefix: | PCO |
| Routing Slip: | PCO_RT1 |
| Distribution: | Group1 |

Type. Enter a code identifying this type of change document.

Design Group. Enter a group defined in Group Maintenance that has design responsibility for this type of change document.

Description. Enter up to 24 characters describing this document type.

Document Type. Indicate whether this type is used for PCRs or PCOs.

Prefix. An optional, three-character prefix for document numbers, used to distinguish different kinds of changes. Prefixes and number sequences are defined in the PCC Control File and used when Auto Number is Yes to determine the number for a new PCO or PCR. If you enter a prefix that is not set up in the control file, a warning displays.

Routing Slip. Enter the routing slip associated with documents of this type. The routing slip determines which groups must approve the document and in what order.

Distribution. Enter the group to be notified when documents of this type are released and distributed with Release and Distribution (1.9.7.1).

Creating PCRs and PCOs

This section focuses on creating PCOs in PCO Maintenance (1.9.2.13). PCR Maintenance (1.9.2.1) is almost identical to PCO Maintenance and is not described separately. It contains two additional functions that enable you to create a PCO based on an approved PCR.

PCO Maintenance (1.9.2.13) is a large and complex program used to create PCOs and add and modify all product change data, including any of the following types:

- Basic header data
- Text detail
- Item detail
- Product structure/formula detail
- Routing/process detail
- Item specification detail
- Trailer data

Submenus in PCO Maintenance enable you to navigate from one PCO section to another.

The header frame of PCO Maintenance contains basic information about the PCO.

Fig. 4.15
PCO Maintenance
(1.9.2.13), Header
Frame

The screenshot shows a window titled "PCO Maintenance" with a menu bar containing "User Menu", "Edit", "Queue", "Options", and "Help". Below the menu bar is a toolbar with several icons. The main area contains the following information:

| | | | | | |
|---------|----------|---------------|--------|-------------|----------|
| Number: | PCD00023 | ID: | | Database: | PCO |
| Type: | PCOTYPE1 | Design Group: | DesGp1 | Created By: | fab |
| | | | | | 07/15/97 |

Below this information are several form fields:

- Title: Major Redesign of Coolers
- Reason: A major enhancement to the motor installed as part of the OASIS Cooler is required to increase its competitive advantage
- Class: Design
- Originator: Field
- User Code [1]:
- User Code [2]:

◆ See “Routing PCRs and PCOs for Approval” on page 122 for details.

A PCO is uniquely identified by a combination of Number, ID, and Database fields. If you enter a combination that does not already exist in the database, a new PCO is created. An error displays if you try to perform maintenance on a distributed PCO, and a warning displays if you open a PCO already routed for approval. If you continue despite the warning, any approvals are essentially revoked, and the document must be rerouted for approval.

If you do not enter a number and Auto Number is Yes in the PCC Control File, the system automatically generates a number based on your entries in PCO Type and Design Group. PCO Type determines the prefix and number, which default from the PCC Control File.

ID. Enables you to create multiple PCOs with the same PCO number for grouping purposes. Typically used to divide large PCOs into smaller ones for ease of implementation. When you open a PCO with a shared number and different ID, you are warned that related PCOs exist.

Database. User-defined. Specifying a database does not automatically create any physical link to, or interaction with, another MFG/PRO eB database. This field is intended for multi-database installations where product development and manufacturing are performed at separate locations. In this case, the same change can have different implementation details at different factories, accommodating variations in specific item numbers, work centers, and so on. Database then becomes an important selection criterion in PCR/PCO Import/Export (1.9.13).

Type and Design Group. This combination must be defined in PCR/PCO Type Maintenance (1.9.1.9). The values specified determine the approval cycle, distribution group, and document change type. If a number is not entered and autonumbering is used, this combination also determines the PCO number.

Once you have created or accessed a PCO, you can enter and change Title, Reason, Class, Originator, and User Codes. These are user-defined and typically used to provide PCO reference summaries. They do not affect PCO processing, but display in PCO Browse (1.9.2.14), Print PCR/PCO (1.9.9.1), and Release and Distribution (1.9.7.1).

After entering basic PCO data, a section menu enables you to navigate elsewhere in PCO Maintenance.

Tip
Review routing slip and distribution group data for a PCO in the trailer, using the Trailer Maintenance menu. The same information displays in PCR/PCO Close (1.9.14).

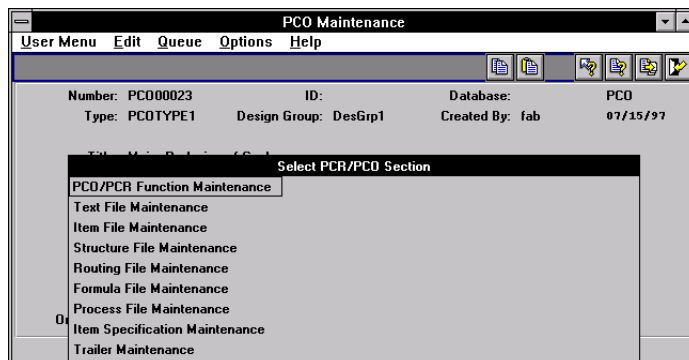

Fig. 4.16
PCO Maintenance, Section Menu

Using PCR/PCO Function Maintenance

This program provides several utilities to support the copying and merging of PCOs and PCRs. A submenu displays several choices.

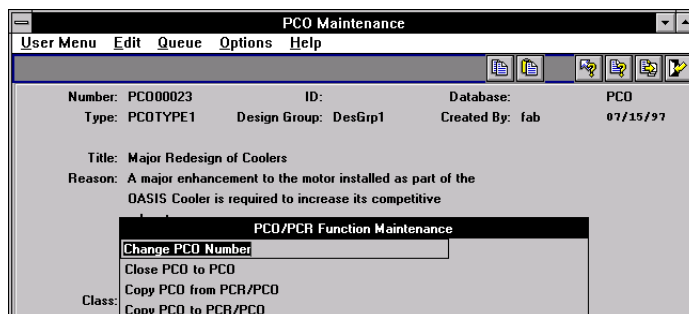
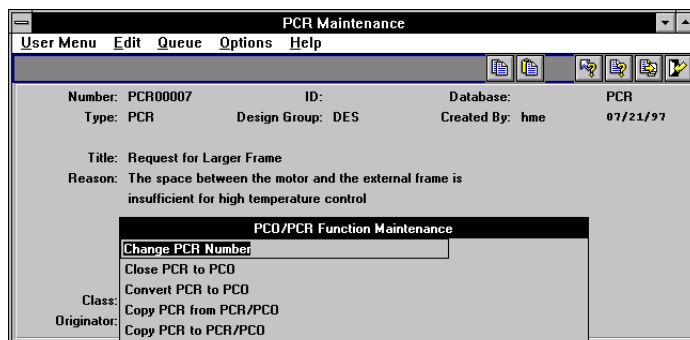

Fig. 4.17
PCO/PCR Function Maintenance Menu

- **Change PCO Number.** Used to change the Number, ID, and/or Database fields of the PCO you are currently editing. Enter new values for these fields to have the system execute the required change immediately. Once completed, the PCO can no longer be accessed using the old number/ID/database values.
- **Close PCO to PCO.** Used to merge detail from the PCO currently being edited into another existing PCO, then close the current PCO. If the same item, product structure, or formula records exist in the target PCO, the corresponding records are not copied.
- **Copy PCO from PCR/PCO.** Used to copy all or part of the detail from another PCO/PCR into your current document. If the same records already exist in the target PCO, they are not copied.
- **Copy PCO to PCR/PCO.** Used to copy all or part of the detail from your PCO to another one. If the same records are already included in the target PCR/PCO, they are not copied.

Two additional functions are available from PCR Maintenance, illustrated in Figure 4.18.

Fig. 4.18
PCO/PCR Function
Maintenance Menu



- **Close PCR to PCO.** Used to merge the detail from the PCR you are currently editing into an existing PCO and then close the current PCR. If the same records exist in the target PCO, they are not copied. This is the only way a PCR can affect the production system, since PCRs cannot be released and distributed.

- **Convert PCR to PCO.** Converts the PCR you are currently modifying to a PCO. You are prompted for a new PCO type and design group, since the current type is designed for PCRs. Once you enter a valid PCO type and design group combination, the PCR becomes a PCO with the same number.

Maintaining Text Files

Select Text File Maintenance to enter multiple pages of text and associate it with a PCO. Another submenu offers two options.

- **Add, Modify, Delete PCO Text Files.** Enables entry of transaction comments for a PCO.
- **Copy Text from Master Comments into PCO.** Enables master comments to be attached to the requested PCO. You can enter the master reference and type in a pop-up frame or leave the fields blank to display a selection list of existing master comments. Select one or more of them for copying into the PCO.

You can use master comments to create reusable text templates that can be pulled into change documents and then edited. They might include legal disclaimers, checklists, standard operating procedures, company policies, or internal surveys.

Tip
Define master comments with Master Comment Maintenance (1.12).

Maintaining Item Files

Select Item File Maintenance to enter changes in item master data. Item-site data, item planning data, inventory data, cost and price data cannot be updated. Only data specified with Item Data Maintenance (1.4.3) can be modified. Another submenu offers two selections.

- **Add, Modify, Delete PCO Item Files.** Enables you to change item master data fields for an existing item. Standard validation prevents the same item master from being changed by more than one undistributed PCO.

Tip
You cannot add new item numbers with this function.

Fig. 4.19
Add, Modify,
Delete PCO Item
Files

Key fields in the program are as follows.

End Product. Specify the end product affected by the PCO. Often, PCO details apply to low-level components that are meant to affect higher-level items. Specifying the end product enables the system to generate reports of PCOs affecting that product, even when the effect is indirect.

Comments. Enter Yes to attach comments regarding the change.

New Rev. Enter a revision level indicator for the item. The item's revision level is updated when the PCO is implemented. Revision levels are alphanumeric codes such as 1b, aa, B3, c.34, 6q3. To use strictly numeric values, fill the number with zeros (0001, 0002, and so on).

The New Rev value must be greater than the Released Rev value, which shows the revision level of the most recently released PCO affecting the item.

Status. New items created for a PCO can be given an item status that prevents their use in live transactions. The status field on the PCO can be set so that at implementation the restricted status is replaced with an active one.

- **Direct Item Master Access.** Enables you to add a new item number and/or enter item master data directly into the production database. This is the only function in PCO Maintenance that directly affects production files. All others build data for incorporation after an approval process.

Item numbers are created in real time rather than in the engineering work space, since important functions may require that they exist

Tip

Revision levels can be skipped, but cannot be specified in descending sequence.

Tip

This function is just like Item Data Maintenance (1.4.3).

before the PCO is released. Impact analysis and the creation of a quotation request are examples of functions that depend on the existence of item numbers.

Maintaining Product Structure Files

Important To use these functions, Product Structures must be Yes in Enable PCC Structure Maintenance (13.13.22). Otherwise, Structure File Maintenance is not available from the Select PCR/PCO Section submenu.

Select Structure File Maintenance to enter product structure additions, changes, and removals. Formula-controlled items must be updated in Formula File Maintenance.

Another submenu offers four selections:

- **Copy Product Structure into PCO.** Copies product structure records into the PCO to serve as a basis for further modification. Displays the current indented bill of material for a given parent item, through a requested number of levels. Copied product structures contain the same field values as production files. You can modify these values using PCR/PCO Detail Maintenance.

Tip
To attach comments to changes made with these functions, set Comments to Yes.

| Level | Component Item | Description | Reference |
|-------|----------------|---------------------|-----------|
| .2 | 44-5000 | CONTROL PANEL,LCD,S | R4 |
| .2 | 44-7000 | PROCESSOR,PRE-PROG | R6 |
| 1 | 55-100 | EVAPORATOR,SERIES 1 | STANDARD |
| * 1 | 55-100 | EVAPORATOR,SERIES 1 | STANDARD |
| 1 | 66-100 | MOTOR,440AC3PHASE | MOTOR |
| 1 | 66-100 | MOTOR,440AC3PHASE | MOTOR |
| * 1 | 66-110 | MOTOR,7500WATT 110/ | MOTOR |
| 1 | 66-110 | MOTOR,7500WATT 110/ | MOTOR |

Use Up and Down arrows to move through list of steps, then Enter to select.

Fig. 4.20
Copy Product Structure into PCO

- **Copy Where Used into PCO.** Works the same as Copy Product Structure into PCO, except it displays an indented where-used bill of material screen, and lets you select product structure records to copy into the PCO. This is useful if you are making the same change to several product structures.
- **PCR/PCO Detail Maintenance–Product Structures.** Used for adding items to product structures, deactivating product structure records, and editing product structure changes already added to the PCO. Records are not actually deleted. Deactivating a record sets an ending effective date when the PCO is incorporated.
- **Replace Product Structure Component.** Used in conjunction with other PCO functions to replace one component item with another across multiple bills of material.

Enter an existing component item number followed by a new one. The system accesses product structure records already included in the PCO, searching for occurrences of the requested component. It marks these product structures Deactivated (end effective date set) and adds new product structures for the same parent items, substituting the new component for the old one.

Fig. 4.21
Replace Product
Structure
Component

| Component Replacement List | | |
|----------------------------|--------------------|------------|
| Component Item | Description | Multiplier |
| | | |
| | | |
| Replace with Item | Description | Multiplier |
| 22-130 | CORD,POWER,UNIVERS | 1.0 |

Multiplier. Modifies the Qty Per value for the new component. The quantity per of the old component is multiplied by this number to determine the quantity per for the new component. As an example, an old component has a quantity per of 2. The multiplier is set to 0.5. The quantity per for the new component is 1.

Other detailed product structure data, such as Scrap % and Op, are copied from the existing record, although you can use other PCO Maintenance functions to change them.

To replace one component item with another across all bills of material, create a PCO and use Copy Where-Used into PCO to include every product structure record that used the old component. Then, use Replace Product Structure Component to deactivate the existing product structure records and add new ones that specify the new component. In this way, you can set up mass component maintenance on a PCO in two relatively simple steps.

Maintaining Routing Files

Important To use these functions, Routings must be Yes in Enable PCC Routing Maintenance (14.22).

Select Routing File Maintenance to make additions, changes, and removals to both standard and rate-based routings. To modify processes, use Process File Maintenance.

The Routing File Maintenance submenu has three selections:

- **Add/Edit/Deactivate Routing.** Used to add operations to a routing, deactivate operation steps, and edit routing changes already added to a PCO. Records are not actually deleted. Deactivating a record sets an ending effective date when the PCO is incorporated.

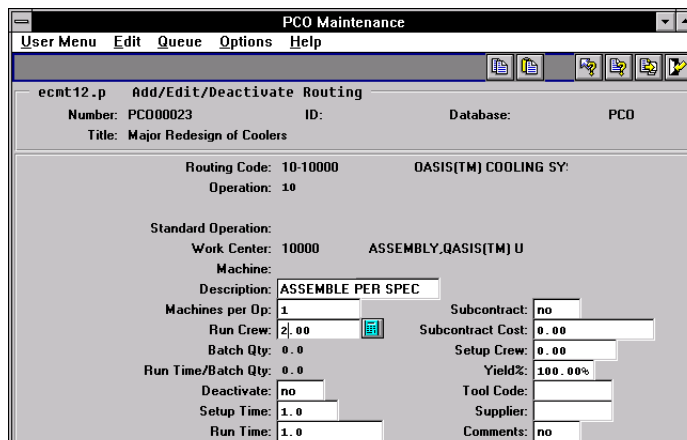
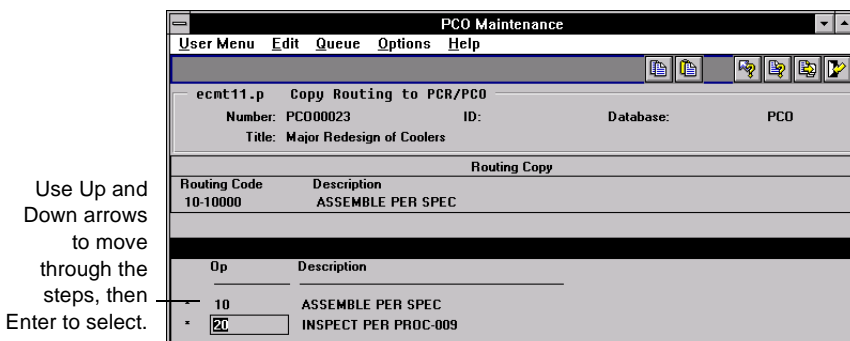

Fig. 4.22
Add/Edit/
Deactivate Routing

- **Add/Edit/Deactivate Routing (Rate Based).** Works just like Add/Edit/Deactivate Routing, except for differences in maintained data fields. The differences are the same as those between standard Routing Maintenance (14.13.1) and Routing Maintenance (Rate Based) (14.13.2).
- **Copy Routing to PCR/PCO.** Copies routing records into the PCO. Displays the operation for a routing and enables you to select any number of steps for inclusion in the PCO. Once copied, operations can be modified with Add/Edit/Deactivate Routing.

Fig. 4.23
Copy Routing to
PCR/PCO



Maintaining Formula Files

Important To use these functions, Formulas must be Yes in Enable PCC Formula Maintenance (15.22).

Select Formula File Maintenance to do the following:

- Copy formulas into a PCO
- Copy where-used data into a PCO
- Maintain PCR/PCO formula details
- Replace formula components

See “Maintaining Product Structure Files” on page 115.

These functions work just like the Product Structure Maintenance functions, except for differences in maintained data fields. The differences are the same as those between Product Structure Maintenance (13.5) and Formula Maintenance (15.5)

Maintaining Process Files

Important To use these functions, Processes must be Yes in Enable PCC Formula Maintenance (15.22).

Use Process File Maintenance to add, edit, deactivate, and copy processes. These functions work just like the Routing File Maintenance functions, except for differences in maintained data fields. The differences are the same as those between Routing Maintenance (14.13.1) and Process Definition Maintenance (15.13).

▶ See “Maintaining Routing Files” on page 117.

Maintaining Item Specifications

Important To use these functions, Item Specifications must be Yes in Enable PCC Item Spec Maintenance (19.1.22).

Use Item Specification Maintenance to manage changes to quality tests associated with an item. You can copy item specifications defined in the Quality Management module and modify them in the PCO.

A submenu provides two selections:

- **Add/Edit/Deactivate Item Specification.** Used to add, modify, and deactivate, test steps for an item specification that has already been added to a PCO. Records are not actually deleted. Deactivating a record sets an ending effective date when the PCO is incorporated.

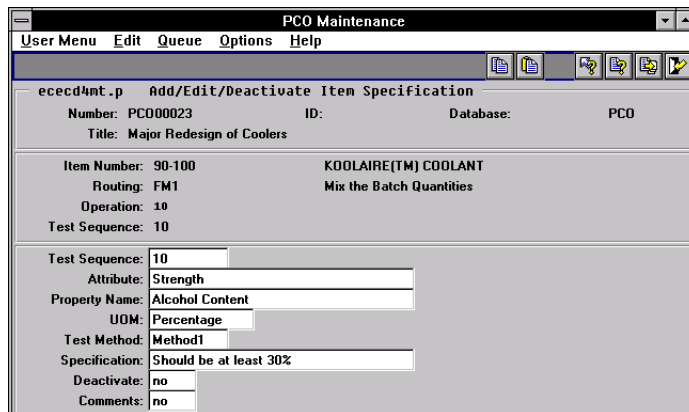

Fig. 4.24
Add/Edit/
Deactivate Item
Specification

- **Copy Item Specification From Quality Module.** Copies item specification records into the PCO. Displays the current sequence of steps for a given parent item and routing.

Fig. 4.25
Copy Item
Specification From
Quality Module

Use Up and
Down arrows
to move
through the
steps, then
Enter to select.

| Seq | Op | Characteristic | Specification | Measure |
|-----|----|-----------------|------------------------|------------|
| 10 | | Alcohol Content | Should be at least 25% | Percentage |
| 20 | | Odor | Pass Panel Approval | Subjective |

Maintaining Trailers

Tip
PCR/PCO Close
(1.9.14) displays
almost the same
information.

Use Trailer Maintenance to maintain important PCO data fields, and to close or reopen a PCO. This program displays release process information such as routing slip, distribution group, date submitted, and date approved. It is the only option that appears in the PCO Maintenance section menu for closed (but undistributed) PCOs.

Fig. 4.26
PCO Trailer
Maintenance

Closed. If Yes, the PCO is closed. If No, the PCO is opened. A PCO cannot be reopened once it is distributed.

Expected Cost. Optional. The expected cost of the PCO.

Disposition. Optional. A user-defined code to describe the arrangement, grouping, or urgency of the PCO. Validated against

codes set up in Generalized Codes Maintenance (36.2.13) for field *ecm_ecr_dspn*.

PCO Ref. Information-only. A cross-reference comment for a closed PCO.

Mandatory. Optional. The latest date on which the PCO must be implemented. A warning message is generated in Incorporation Selection (1.9.7.4) if an effective date is assigned to the PCO that is later than this date.

Tip
The mandatory date is an engineering instruction to manufacturing, since the manufacturing group is responsible for PCO incorporation.

Reviewing PCO Data

Use PCR/PCO Detail Inquiry (1.9.2.8) to display PCR or PCO details.

Use Print PCR/PCO (1.9.9.1) to select and print a range of PCO/PCR details. Selection criteria include number, type, and created by. Set a comment page range to include comment pages attached to the PCO.

The Approvals flag determines whether or not approvals are printed. To print PCOs in various life-cycle stages, use the status flags: Pre-submission, Submitted, Approved, Released, Incorporated, Implemented, Closed.

Use PCO Status Browse (1.9.11) to review the current status of PCRs and PCOs. The following statuses reflect the position of the PCR or PCO in the change life cycle:

- Submitted
- Rejected
- Approved
- Released (PCO only)
- Distributed (PCO only)
- Incorporated (PCO only)
- Implemented (PCO only)
- Closed

Use Approval Browse (1.9.6.2) to review sign-offs for a given PCO, including pending and completed approvals, individual approvers, and date of the approvals.

Routing PCRs and PCOs for Approval

Tip
Use 1.9.2.4 for
PCRs.

Route PCOs for approval using Route PCO for Approval (1.9.2.16). To route PCRs, use Route PCR for Approval. After a PCO is submitted, it can be approved with PCR/PCO Approval.

Once a PCR or PCO has been routed, the system restricts changes to the document to ensure that the approved document is the most current. If a routed PCR or PCO is accessed in the maintenance function, a warning displays. If you continue despite the warning, you can modify the PCO, but all approvals are reset to No, and each group on the routing must reapprove.

If a group disapproves a PCO and severity levels apply, the PCO can be rerouted to selected groups based on the severity of changes required. Only approvals of groups that need to review the document are reset.

Fig. 4.27
Route PCO for
Approval (1.9.2.16)

The screenshot shows a window titled "Route PCO for Approval" with a menu bar (User Menu, Edit, Queue, Options, Help) and a toolbar. Below the menu is a form with the following fields:

| | | | |
|------------------|-----------|--------|-------------------|
| Number: PCO00010 | ID: | DBase: | DocType: PCO |
| Type: | Dsgn Grp: | By: | Unsubmt Only: yes |

Below this form is a table listing PCOs:

| Number | ID | Database | Title | By | Sub Date |
|----------|----|----------|----------------------------|-----|----------|
| PCO00019 | | | Changes required for 99-10 | ljm | |
| PCO00021 | | | Minor upgrade for 22-100 | vxb | |
| PCO00022 | | | Performance Ehnhancemen | ljm | |
| PCO00023 | | | Major Redesign of Coolers | fab | |

At the bottom of the window is another table for submission details:

| Number | ID | Database | Title | By | Sbmt | Cmmt |
|----------|----|----------|---------------------------|-----|--|--|
| PCO00023 | | | Major Redesign of Coolers | fab | <input type="checkbox"/> yes <input type="checkbox"/> no | <input type="checkbox"/> yes <input type="checkbox"/> no |

Tip
Set Unsubmt Only
to No if you want to
revoke a submitted
PCO.

Route PCO for Approval lists PCOs in order, beginning with the number you enter in the first frame. Select PCOs to display by PCO Type, Design Group, and By (Created By). Use Unsubmt Only to display unsubmitted PCOs, or set it to No to see both submitted and unsubmitted PCOs.

Select a PCO for submittal, and set Sbmt to Yes in the bottom frame. The system displays a submit date for the PCO. To unsubmit a submitted PCO for which no approvals have been given, set Sbmt to No. A partially approved PCO must first have all electronic approvals changed from Yes to No. Once unsubmitted, additional changes can be made, and the approval cycle started again.

To attach comment pages, set Cmmt to Yes.

Approving PCRs and PCOs

Approve PCOs using PCR/PCO Approval (1.9.6.1). Designated reviewers can enter electronic approvals or disapprovals, along with comments.

PCR/PCO Approval lists approval records by criteria you enter at the top of the screen. Enter a PCO number to have approvals listed starting with that PCO. Either PCRs or PCOs can be listed depending on the value entered in DocType. When multiple approval records exist for a document, they are listed by approval sequence.

Specify an approval group to display only approvals required of that group. Specify a user ID to display only approvals required of groups that include that user.

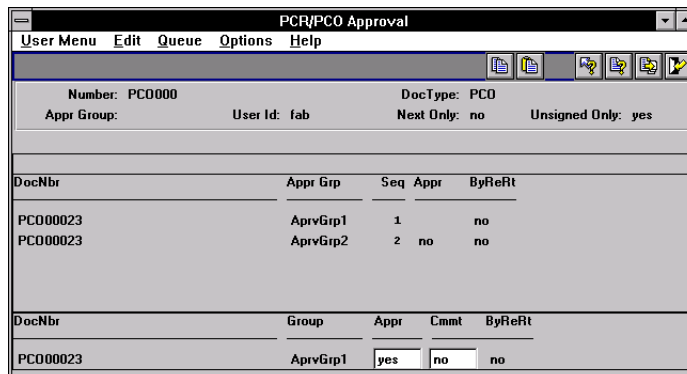

Fig. 4.28
PCR/PCO
Approval (1.9.6.1)

Unsigned Only. Enter Yes to display pending approvals. If Yes, documents are excluded from the display when only one of several groups has given approval.

Enter No to display both approved/disapproved and pending approvals. For each required approval, the group designated to perform the approval displays.

Appr. Enter No to disapprove previously approved PCOs. Enter Yes to approve previously disapproved PCOs.

▶ See “Defining Approval Routings” on page 104 for details.

Rerouting PCOs

If the reviewer disapproving a change document belongs to a group with Can Re-Route set to Yes on the routing slip, PCR/PCO Approval prompts for a reroute level. Reroute level signifies the magnitude of the problem noted by the reviewer. If you do not want to reset approvals, enter zero for the reroute level. Higher reroute levels require more groups to reapprove the document.

When a reroute level is specified, the system examines Severity Level for each group on the routing slip. If Severity Level is less than or equal to the reroute level, the system changes the approval to No, indicating that the group must review the document again. To enter explanations for the reroute, set Cmmt to Yes.

When a document requires approval as a result of this process, the ByReRt flag in PCR/PCO Approval is set to Yes.

Detail Approval Maintenance

To change or override the standard approval process, use Detail Approval Maintenance (1.9.6.13). Typically, this program is password controlled, since it provides an administrative override to the standard approval function.

While it lets you override the normal approval process, it does not exactly duplicate it. For example, disapproved documents are not rerouted. To reroute, use PCR/PCO Approval.

Incorporating PCOs into Production

Once a PCO is approved, use the PCO Implementation menu (1.9.7) to update production data, as follows:

- 1 Use Release and Distribution (1.9.7.1) to release the PCO and notify members of the distribution group.
- 2 Use Incorporation Planning Report (1.9.7.3) to analyze the impact of the PCO on current inventory and help determine the best effective date for incorporation.
- 3 Use Incorporation Selection (1.9.7.4) to specify an effective date.

- 4 Run Incorporation (1.9.7.5) on a daily basis to incorporate PCO changes into production files. Changes become effective on the date specified in step 3.
- 5 Run Implementation (1.9.7.13) on a daily basis to copy changes to item data records from PCOs effective on the current date into the item master file.

PCO Release and Distribution

After a PCO is approved, it is ready to be released and distributed. Releasing a PCO typically means transferring ownership of it from a design organization to a manufacturing or production organization. Distributing means notifying members of a distribution group of a PCO’s release. This can be done with hard-copy reports or E-mail, depending on how the routing slip is set up.

Use Release and Distribution (1.9.7.1) to release and distribute PCOs. Release and distribution are initiated at the same time, but are recorded as separate points in the PCO life cycle. When a released PCO is distributed through a standard batch processing queue, significant time may elapse between release and actual distribution. Once a PCO is distributed, its release is final.

Release and Distribution (1.9.7.1) lists PCOs by criteria entered at the top of the screen. Enter a PCO number to list PCOs beginning with that number.

Tip
 Since PCRs cannot be released to production, they are never listed on the screen.

The screenshot shows a software window titled "Release and Distribution" with a menu bar (User Menu, Edit, Queue, Options, Help) and a toolbar. Below the toolbar, there are fields for "Number: PCO00023", "ID:", "Database:", "Type:", "Created By:", and "Unreleased Only: yes".

| Number | ID | Database | Title | Sub Date | Batch ID |
|----------|----|----------|----------------------------|----------|----------|
| PCO00023 | | | Major Redesign of Coolers | 07/16/97 | no |
| pg1a | | | Reroute to new work center | | no |
| pg1b | | | Modify product structure | | no |
| pg1c | | | Increase Run Time for Oper | | no |

| Number | ID | Database | Title | Rele | Comt | Batch ID |
|----------|----|----------|---------------------------|------|------|----------|
| PCO00023 | | | Major Redesign of Coolers | yes | yes | |

Fig. 4.29
 Release and Distribution (1.9.7.1)

Unreleased Only. Enter Yes to view only unreleased PCOs. Enter No to view both released and unreleased PCOs, or to revoke a previously released, but not yet distributed, PCO.

Rel.s. Enter Yes to release the PCO, or No to unrelease it, assuming the PCO has been released but not yet distributed.

Batch ID. Specify a batch queue for printing release notices. Leave blank to print notices immediately. Since actual distribution of PCOs occurs only after reports are printed, queuing may result in lag time between release and distribution.

Incorporation Planning Report

Incorporation Planning Report (1.9.7.3) helps planning personnel evaluate the impact on inventory of implementing a PCO on a given effective date. To run the report, enter a specific PCO number, ID and/or database, site, effective date, and cost method.

Tip
This summary is similar to the Materials Summary Report (13.8.20).

The report shows the summarized BOM/formula of each parent item from all product structure/formula records changed by the PCO. It lists components from all levels of the item's BOM or formula. The Qty Per values are extended to show the total quantity required per end item, rather than per single-level parent.

Table 4.2 summarizes the information displayed for each component.

Table 4.2
Component
Amounts

| Information | Amount |
|--------------------|--|
| Original Qty Req'd | Quantity per end-item for the currently effective product structures/formula records. |
| Final Qty Req'd | Quantity per end-item for product structure/formula records after the PCO has been implemented. |
| Qty On Hand | Current on-hand inventory balance for the component. |
| Qty On Order | Total quantity of supply on order for the component due on or before the entered effective date. |
| Projected Usage | Total demand quantity required for the component due on or before the entered effective date. |

| Information | Amount |
|-------------|--|
| Balance | Total of Qty On Hand + Qty On Order – Projected Usage, yielding the component’s expected on-hand inventory balance as of the entered effective date. |
| Value | Total monetary cost of the component inventory quantity in the Balance field, using the item costs associated with the entered Cost Method. |

Use this report to estimate the future cost of obsolete inventory as of a given effective date. Run the report with different effective dates to determine which effective date minimizes inventory scrap/rework costs.

Typically, this report is considered in combination with other factors, such as the impact of changed routings/processes, new tooling, scrap and rework costs, purchased part lead times, and the mandatory date for the change. Nonetheless, future component inventory balances are relevant in almost all situations and provide valuable planning information.

Incorporation Selection

Use Incorporation Selection (1.9.7.4) to set PCO effective dates. Released and distributed PCOs display in order beginning with the PCO entered in the first frame. Enter criteria such as Type and Created By to show only PCOs matching those criteria.

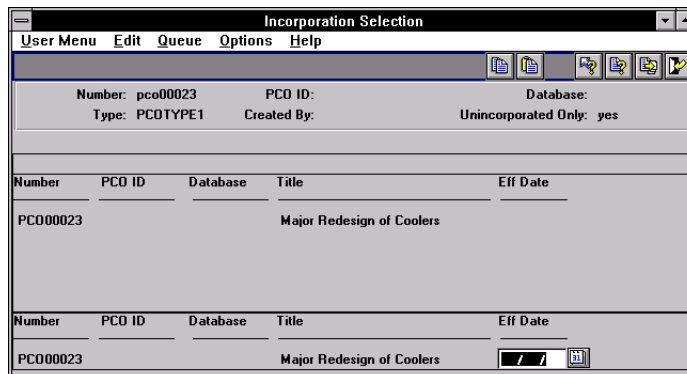

Fig. 4.30
Incorporation
Selection (1.9.7.4)

Unincorporated Only. Enter Yes to view only PCOs that are distributed but not yet incorporated. Enter No to view all distributed PCOs.

If different PCOs change item master data for the same item, MFG/PRO eB (and standard practice) requires them to be incorporated in revision level sequence. The system displays an error if you set PCO effective dates out of sequence or give more than one PCO the same effective date.

If a PCO has a mandatory date, a warning displays if the effective date is not on or before this mandatory date.

Incorporation

Once a PCO effective date is established, the PCO can be incorporated into product definition files. At this point, you can still change PCO effective dates or even remove PCOs from the production system. Any incorporated PCO not yet implemented can be unincorporated or reincorporated by changing the PCO effective date.

Incorporation (1.9.7.5) updates the MFG/PRO eB database with changes from PCOs for which effective dates have been set. Incorporation makes change data available to MRP, DRP, and the other preproduction modules.

Incorporation generates an audit trail report of database updates and any errors encountered. For example, if two PCOs with the same effective date update the same records, only changes from the first PCO are incorporated. The second is highlighted as an error on the report.

Assuming that Incorporation Selection has been run, PCO Incorporation is essentially a batch update process requiring no input from the user. Typically it is set up and executed as a daily batch job.

After incorporation, MRP and DRP automatically use the new effective dates in all planning processes.

Implementation

Once the effective date of a PCO is reached, the revision level of changed item numbers must be updated. This field displays in the Rev field of Item Data Maintenance.

Implementation (1.9.7.13) copies changes to item data records, from PCOs effective on the current date, into the item master file.

Implementation is designed to be a daily batch job requiring no user input.

Closing PCRs and PCOs

Use PCR/PCO Close (1.9.14) to close or reopen any PCO that has not been assigned an effective date in Incorporation Selection (1.9.7.4). You can close PCOs that have been released and distributed but not incorporated. Close undistributed PCOs in the trailer of PCO Maintenance.

Closed. If Yes, the PCR or PCO is closed. This field is reference-only, and does not establish a link to another PCO in the same way as Close PCO to PCO function in PCO Maintenance.

PCO Ref. Optionally, enter a value as a cross-reference.

Closing a PCR or PCO in this way makes a PCO available for export to another MFG/PROeB database.

Tip

Also use this program to close PCRs that are not closed by becoming part of a PCO.

▶ See page 120 for details on PCO/PCR trailer fields.

Importing and Exporting PCRs and PCOs

Use PCR/PCO Import/Export (1.9.13) to export closed PCO data to an ASCII file for import into another database or application, such as a Product Data Management system.

Fig. 4.31
PCR/PCO Import/
Export (1.9.13)

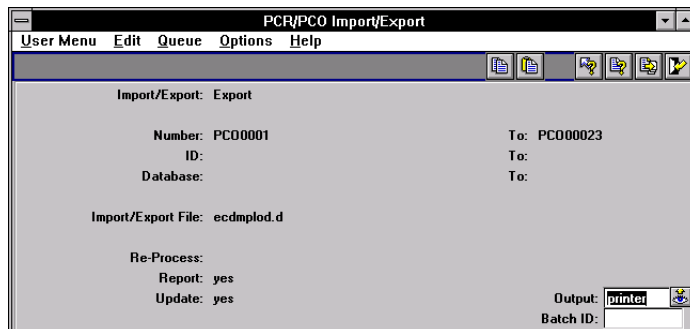

Use the import function to restore archive files created by PCR/PCO Delete/Archive (1.9.15), which is similar to standard delete/archive programs.

Re-Process. Only available when you are importing data. Enter Yes to have the Type and Design Group of imported PCRs and PCOs set to blank. The closed status is also removed and set to blank. This enables you to assign new types and design groups appropriate for the new database. If No, a PCO with a Type and Design Group combination that does not exist in the new database is not imported.

Setting Up PCC Security

Since PCC activities can affect your production environment, the following security steps are advised:

▶ See “Setting Up the PCC Control File” on page 98 for details.

- Set Security in the PCC Control File to Yes for additional control of approvals.
- Place menu-level security on PCR and PCO Maintenance programs, and on update functions elsewhere in the system.

Access to PCO Maintenance Detail Functions

Each submenu in PCR and PCO Maintenance exists as a menu entry in the Product Change Utility Menu (1.9.25). Using Menu Password Maintenance (36.3.1) to restrict access to a program on menu 1.9.25 also restricts access to the corresponding program in PCO Maintenance.

Example Restricting access to Item File Maintenance (1.9.25.3) also restricts access to the Item File Maintenance screen of PCR or PCO Maintenance.

Restricting Access to Other Functions

Once PCC is implemented, prevent direct modification of controlled records by setting menu security on the following programs:

- For product structures, Product Structure Maintenance (13.5), Product Structure Copy (13.9), Component Change (13.10), Alternate Structure Maintenance (13.15), and Configured Structure Maintenance (8.1)
- For routings, Routing Maintenance (14.13.1), Routing Maintenance (Rate Based) (14.13.2), Routing Copy (14.13.6), Routing Update (14.13.7)
- For formulas, Formula Maintenance (15.5), Formula Copy (15.8), Batch Quantity Change (15.9)
- For processes, Process Definition Maintenance (15.13), Process Definition Copy (15.16), Process/Formula Maintenance (15.18)
- For item specifications, Item Specification Maintenance (19.1.13)

Additionally, set password protection on Detail Approval Maintenance (1.9.6.13). Only use this program in situations that require immediate modifications of PCO approvals.

Introduction

▶ See “Setting Up Compliance” on page 136.

This section includes a brief description of each compliance feature. Once you choose the features you will use, you can begin setup. Features using item data, user information, and other MFG/PRO eB elements may require setup in additional programs.

Table 5.1
Compliance Menu

| Menu | Description | Program |
|---------|-----------------------------------|-----------|
| 1.22 | Compliance Menu | |
| 1.22.1 | Lot Master Maintenance | clltmt.p |
| 1.22.2 | Lot Master Inquiry | icltmiq.p |
| 1.22.4 | Work Order Attribute Maintenance | clatmt.p |
| 1.22.5 | Work Order Attribute Browse | clbr001.p |
| 1.22.9 | Work Order Batch Browse | clbr002.p |
| 1.22.13 | Lot Group Maintenance | cllgmt.p |
| 1.22.14 | Lot Group Inquiry | cllgiq.p |
| 1.22.16 | Controlled Substances Menu | |
| 1.22.19 | Multi-Lot Inventory Detail Update | clltamt.p |
| 1.22.22 | Lot Master File Build | clltbd.p |
| 1.22.23 | Lot Master Delete/Archive | clltup.p |
| 1.22.24 | Compliance Control File | clclpm.p |

▶ See “Managing Controlled Substances” on page 162 for Controlled Substances Menu details.

Site Security

Site security is not part of the compliance module, but is frequently used in conjunction with other compliance features. Site security enables administrators to control user access to sites by individual and group membership. It integrates user maintenance and security control with inventory transactions at the site level. Only authorized users can process inventory transactions for secured sites.

▶ See *User Guide Volume 9: Manager Functions* for details on site security.

Site Security Maintenance (36.3.16) is located on the System Security Menu in the Manager Functions module.

Inventory Attributes

Attribute information can be entered on work orders, increasing control over the tracking of materials through manufacturing and into inventory. With these attributes, you can use batch and other work order processes to meet your business requirements. There are several ways to assign default inventory attributes and change existing attributes such as assay percentage, grade, expire date, and inventory status.

Especially important is the ability to assign an inventory status during work order or purchase order receipt. This status can be used to override the status normally assigned to a location. Using receipt statuses reduces the need for separate physical locations for regulated business practices.

Note You do not need to have the Compliance module to assign inventory statuses during receipt. However, this feature is especially useful in regulated environments.

Batch Control

Batch control enables you to assign batch numbers to work orders. Batch numbers can be used for traceability and reporting. You can enter batch numbers as you create work orders or add them to existing work orders through a maintenance window.

Component Issue Control

Compliance features let you restrict items issued to work orders to those listed on the bill of material (BOM) or valid substitutes. There is a similar control for receipts of co-product/by-product items.

Lot Control

You can enforce unique lot numbers, define lot groups for assigning lot numbers, update inventory attributes for multiple lots, restrict receipts to a single lot, generate reports with lot numbers as an index, enter supplier lot numbers, and manage expired inventory.

Multi-Lot Inventory Detail

You can change inventory assay %, grade, status, and expire date attributes based on lot/serial number.

Controlled Substances

You can maintain lists of regulatory agencies, link a regulatory or control number to an address code or site, associate a regulatory or control number to an inventory item, and record general ledger (GL) and individual license information for U.S. exports.

Setting Up Compliance

Compliance features are activated and configured in the Compliance Control File (1.22.24).

Fig. 5.1
Compliance
Features and
Compliance
Control File

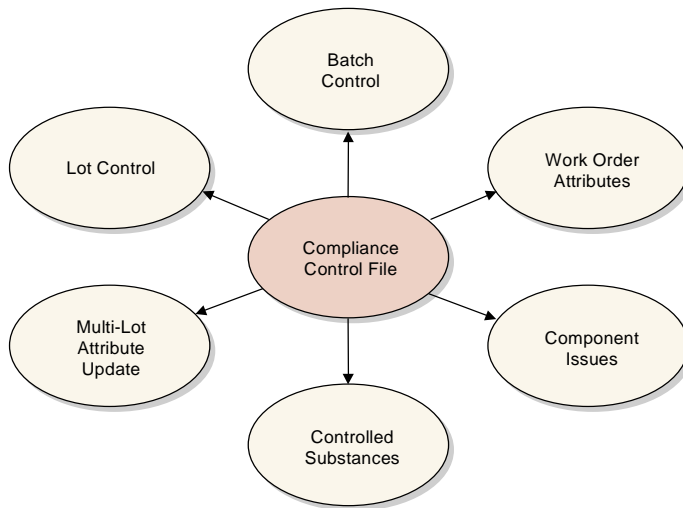

Use the Compliance Control File, illustrated in Figure 5.2, to set up these features.

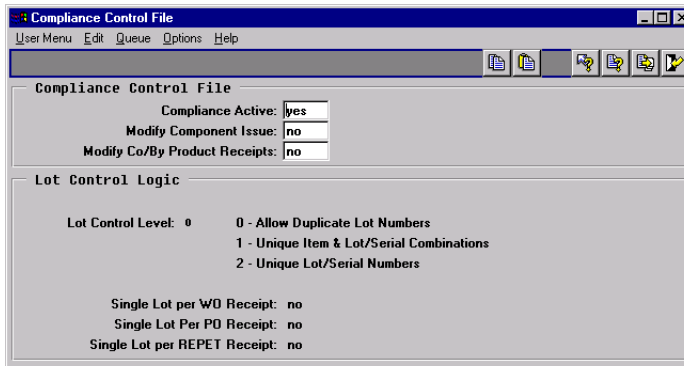

Fig. 5.2
Compliance
Control File
(1.22.24)

Compliance Active. Enter Yes or No depending on which compliance features you want to use:

No: Only lot control features are active, based on the setting of Lot Control Level.

Yes: Work order attributes (including batch numbers), expired inventory transactions, and controlled substances are active.

Modify Component Issue. Enter Yes to issue any component to a work order. Enter No to restrict items issued to a work order to those listed on the work order bill of material (BOM) or valid substitute items.

Modify Co/By-Product Receipts. Enter No to require all receipts to be valid items or substitute items for a co-product or by-product in a joint work order set. Enter Yes to allow any item to be received as an unplanned receipt.

Lot Control Level. Enter 0, 1, or 2.

0–Allow Duplicate Lot Numbers. Any lot number can be specified for any item number.

1–Unique Lot/Serial per Item Number. You cannot assign an item on an order a lot or serial number that is already used by that item on another order. For example, if work order WO1 assigns item A a lot number of 10, no other purchase or work order can assign lot number 10 to item A.

2–Unique Lot/Serial Numbers. You cannot assign an item a lot or serial number that is already used by another item in inventory. For example, if item A has a lot number of 10, item B cannot be assigned

Tip
Set up substitute items in Item Substitution Maintenance (13.19).

a lot number of 10. Rework work orders, expense work orders, and distribution orders do not have this restriction.

▶ For more information on the effects of the Single Lot fields, see “Single Lot per Receipt” on page 159.

Single Lot per WO Receipt. Indicate whether work order receipts are restricted to a single lot.

No: Multiple receipts for an order can use the same lot number, if needed.

Yes: A new lot number is required for each receipt.

This setting determines the default for the Single Lot field of Work Order Receipts (16.11) and Work Order Receipt Backflush (16.12), where it can be changed as needed.

Note The Single Lot settings have no effect when Lot Control Level is set to 0.

Single Lot per PO Receipt. Indicate whether purchase order receipts are restricted to a single lot.

No: Multiple receipts for an order can use the same lot number, if needed.

Yes: A new lot number is required for each receipt.

This setting determines the default for the Single Lot field of Purchase Order Receipts (5.13.1), where it can be changed as needed.

Single Lot per REPET Receipt. Indicate whether end-item receipts in repetitive transactions are restricted to a single lot.

No: Multiple receipts for an order can use the same lot number, if needed.

Yes: A new lot number is required for each receipt.

This setting determines the default for the Single Lot field of Repetitive Labor Transaction (18.14), as well as Backflush Transaction (18.22.13) and Move Transaction (18.22.19) in Advanced Repetitive.

Tip

This setting also affects Returns to Supplier (RTS) in the Service/Support Management module. When this field is Yes and you have received an item lot, you cannot receive it again on an RTS.

Defining Inventory Attributes

Attributes are critical to managing the flow of inventory in a warehouse. Of the various attributes, status is the most important, since you can restrict transactions based on status. When compliance is active, you have more options for setting and using attributes.

Typically, the status of an item is determined by its location. In a regulated environment, a special status for quarantined items is often created and assigned to a particular location. Quarantined items are held in that location until they are inspected, approved for use, and transferred to a stocking location.

The use of separate physical locations may not be required, however, if items are marked for quarantine with some other method. For example, some companies use a removable label. You can use inventory statuses to support this business methodology.

To implement this practice in MFG/PRO eB, you first create a quarantine status in Inventory Status Maintenance (1.1.1). Then specify this status as the active default for purchase order and work order receipts in Item Master Maintenance. When items are received, the system assigns each lot a quarantine status, overriding the status of the location. After the lot is inspected and approved, the inventory status can be changed using Multi-Lot Inventory Detail Update (1.22.19). The lot no longer needs to be physically transferred to change its status.

Figure 5.3 illustrates setting inventory attributes in the work order Attributes frame. While batch and lot numbers are not technically attributes, they are located on the same frame so that they can be entered at order creation and updated during work in process.

Tip

You can also set default inventory attributes for purchase orders and repetitive transactions.

Fig. 5.3
Work Order
Maintenance
(16.1), Attributes
Frame

The Attributes
frame displays
in Work Order
Maintenance
and Work Order
Attribute
Maintenance.

The screenshot shows a window titled "Work Order Maintenance" with a menu bar (User Menu, Edit, Queue, Options, Help) and a toolbar. The main area displays work order details: Work Order: 1004, ID: 1007, Item Number: 88-4000, Type: PLASTIC PELLETS, Site: 10000, MIL-999-001. Below this is an "Attributes" section with the following fields: Assay %: 95.00%, Grade: B, Expire Date: 09/30/98, Receipt Status: Inspect, Active: no, Batch: Batch060798, Single Lot: yes (with a text input field), and Lot Number: (with a text input field).

Work order attributes are stored in the work order master file. If Compliance Active is Yes, you can assign work order attributes, batch number, and lot number to end items in Work Order Maintenance (16.1), when you first create the work order. When Compliance Active is No, only the Single Lot field can be modified.

When you receive items into inventory, you can modify assay %, grade, expire date, and receipt status, unless items with the same lot and reference numbers already exist in the location with different attributes. If you have not specified attributes on the work order and no inventory detail records exist, the system assigns default values from location or site records.

Note You can always modify attributes at receipt, regardless of the setting of Compliance Active.

Why Are Attributes Important?

While attributes are described here primarily for work orders, attributes also relate to purchase orders, repetitive transactions, and advanced repetitive transactions. Attributes you enter on an order eventually are assigned to inventory records during order receipt—whether it is a purchase order, work order, or repetitive transaction. The only difference among order types is where in the order process the attributes are assigned.

The inventory status attribute can be defined for any unique combination of item number, site, location, lot/serial, and reference. The following table describes which attributes can be defined for each order type and indicates the programs you use to define them.

▶ See “Inventory Attribute Active Field” on page 144.

Table 5.2
Inventory
Attributes

| Order or Attribute Type | Menu | Attributes |
|--------------------------------|---|---|
| Work Order | Work Order Maintenance (16.1) Work Order Attribute Maintenance (1.22.4) Work Order Receipts Pop-Up Window (16.11) | Assay% Grade Expire Date Receipt Status/Active |
| Purchase Order | Purchase Order Receipts Pop-Up Window (5.13.1) | Assay% Grade Expire Date Receipt Status/Active |
| Repetitive | Repetitive Labor Transaction Pop-Up Window (18.14) Advanced Repetitive Backflush Transaction Pop-Up Window (18.22.13) Advanced Repetitive Move Transaction Pop-Up Window (18.22.19) | Assay% Grade Expire Date Receipt Status/Active |
| Inventory Status | Item-Site Inventory Data Maintenance (1.4.16) Item Inventory Data Maintenance (1.4.5) Item Master Maintenance (1.4.1) | PO Rcpt Status WO Rcpt Status |
| Inventory Status | Location Maintenance (1.1.18) Site Maintenance (1.1.13) | Inventory Status |

You can use the two programs in boldface type to modify attributes only when Compliance Active is Yes.

Note You can change inventory attributes only for purchase orders with a blank type. This restriction excludes blanket purchase orders and PO returns.

Inventory Attributes Work Flow

Figure 5.4 shows a typical work flow for setting up inventory attributes.

Fig. 5.4
Inventory
Attributes Work
Flow

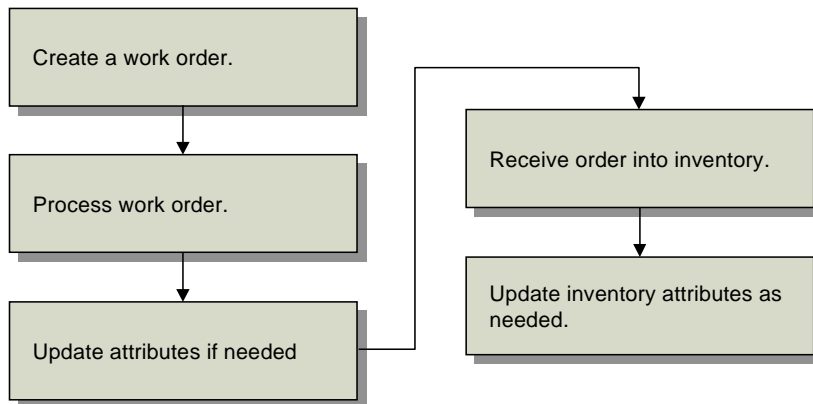

Once compliance has been activated in the Compliance Control File, you can create and process work orders according to your normal procedures. If needed, you can update item attributes directly using Work Order Attribute Maintenance (1.22.4).

Then receive the work order using Work Order Receipt (16.11) or Work Order Operation Backflush (16.19). After the items have been received, attributes can be modified again as needed using Multi-Lot Inventory Update (1.22.19) or Inventory Detail Maintenance (3.1.1).

Attribute Descriptions

Table 5.3 lists work order attributes. Each attribute is a field in Work Order Attribute Maintenance (1.22.4) and the Attributes frame of Work Order Maintenance (16.1). Attributes, lot number, and batch number also appear in receipt programs and other programs.

Table 5.3
Attribute
Descriptions

| Attribute | Description | Usage |
|------------------|---|---|
| Assay% | The presence, absence, or quantity of one or more components, usually expressed as a percentage. | Formulations may require a minimum assay percentage. These values are reviewed prior to allocating or picking stock from inventory. |
| Grade | Identifies the quality or physical properties of an inventory quantity. Graded products include raw materials, intermediates, and finished goods. | Formulations may require a minimum grade. These values are reviewed prior to allocating or picking stock from inventory. Grade may determine the price charged for the finished product. |
| Expire Date | The expiration date for items that eventually spoil, and for pharmaceuticals that lose potency over time. | If you try to allocate, ship, or issue expired inventory, you get an error message. If expired inventory is recertified, assign a new expiration date in Inventory Detail or Multi-Lot Attribute Update. |
| Receipt Status | The default receipt status for the order. | Items may require a status assigned to them upon receipt. For example, dangerous or fragile items may need quarantine or inspection before shipment or component issue. Define status codes in Inventory Status Code Maintenance (1.1.1). |
| Active | Indicates whether the inventory status code entered in Receipt Status should override status assigned in item, site, and location data. | Use this field to override default settings assigned in item, site, and location data records. See “Inventory Attribute Active Field” on page 144 for more information. |
| Batch | An arbitrary number for tracking a quantity scheduled to be produced or in production. See “Using Work Order Batch Control” on page 147 for information on using batch numbers. | You can use batch numbers for tracking a group of lots or a portion of a lot. The system does not validate batch number, but you can report on batches with Work Order Batch Inquiry (1.22.9). |

| Attribute | Description | Usage |
|------------|--|---|
| Single Lot | Determines whether each receipt from a work order should be assigned to a single lot. This is a default setting you can change at receipt. Single Lot also appears in Purchase Order Maintenance. See “Using Lot Control” on page 151 for details. | For additional control, you can force each receipt to be received into a single lot by setting to Yes. If the order is for a serialized item, this field is automatically set to Yes and cannot be changed. You cannot change this setting under the following conditions: once items have been received against this order (line item for POs), for rework or expense work orders (type R or E), or if the order is part of a joint work order set. |
| Lot Number | The lot number for this work order. Enter a lot number in this field. See “Using Lot Control” on page 151 for information on using lot numbers. | When Single Lot is No, you can enter a lot number for this work order. The system validates this field for uniqueness when Lot Level is set to 1 or 2. With the above conditions met, entering a lot number at order reserves that number in the Lot Master file. |

Inventory Attribute Active Field

You can override inventory status and other attribute information for an item during receipt, *except* when the status or other attribute conflicts with existing items with the same lot and reference number at a location. When this occurs, an error displays and you have two choices:

- Change the site, location, lot, and reference to identify a different inventory location.
- Change the Active field of the inventory status or other attribute to No. The system then uses the attribute of the already existing inventory detail record.

Overriding Default Attributes

To override attributes at receipt, set the Set Attributes field to Yes in Work Order Receipt (16.11), Work Order Operation Backflush (16.19), Purchase Order Receipts (5.13.1), Repetitive Labor Transaction (18.14), Backflush Transaction (18.22.13) and Move Transaction (18.22.19) in Advanced Repetitive, or RTS Receipts (11.7.3.13).

Quantity: 10.0
 UM: KG
 Conversion: 1.0000
 Scrapped Qty: 0.0
 UM: KG
 Conversion: 1.0000

Site: 10000
 Location: 88
 Lot/Serial:
 Ref:
 Multi Entry: no
 Set Attributes: yes
 Total Units:

Fig. 5.5
Set Attributes Field

A pop-up window displays the current attribute settings.

Scrapped Qty: 0.0
 UM: KG
 Conversion: 1.0000

Remarks:
 Effective:
 Close:

Ref:

Receipt Attributes

Assay %: 95.00% Active: yes
 Grade: B Active: yes
 Expire Date: 09/30/98 Active: yes
 Inventory Status: Active: no
 Use As Default: no

Fig. 5.6
Receipt Attributes Pop-Up

Change attributes as needed and choose Yes in the associated Active field to use your selections.

- Choose Yes in the Use As Default field to assign the entered attributes as defaults for the current order. All future receipts to the same order will have the specified attributes.
- Choose No in all of the Active fields and choose Yes in the Use As Default field to clear the default values. All attribute values are set to blank for this order.
- If inventory exists for a location, lot, and reference combination with attributes that are different from the ones on this order, an error message displays. Choose No in the Active fields of the conflicting attributes to correct the error.

Active Fields and Blank Inventory Status

Active fields enable you to enter a blank for a valid inventory status. For example, if the PO Rcpt Status field is blank, the system cannot determine whether you want to assign a blank status code, or if you want to accept a default setting previously assigned to an item, location, or site. The Active field solves this problem. If the Status field is blank and Active is Yes, then a blank status is assigned. Otherwise, if the Status field is blank and Active is No, the system assigns the status based on another default, as described in Table 5.4.

Attribute Order of Precedence

Table 5.4 shows the search order the system uses to determine default inventory attributes. If values have not been defined in any of these programs, the default attribute is blank.

Table 5.4
Attribute Search
Order

| Order of Precedence | Location of Inventory Status Values | Menu Number | Field Name | Active |
|---------------------|--|----------------|----------------------------------|------------|
| 1 | Inventory Detail Record | | Inventory Status | N/A |
| 2 | Work Order Maintenance Work Order Attribute Maintenance | 16.1 1.22.4 | Receipt Status Receipt Status | Yes Yes |
| 3 | Item-Site Inventory Data Maintenance | 1.4.16 | PO Rcpt Status WO Rcpt Status | Yes Yes |
| 4 | Item Master Maintenance | 1.4.1 | PO Rcpt Status WO Rcpt Status | Yes Yes |
| 5 | Location Maintenance | 1.1.18 | Inventory Status | N/A |
| 6 | Site Maintenance | 1.1.13 | Inventory Status | N/A |

Figure 5.7 illustrates how these rules can be applied. In this example, assume that all of the items are in the same lot and have the same reference number.

Item A, which has a default inventory status of 5, cannot be received into Location L. This is because the same item already exists in this location with the same lot and reference numbers and a different status. Item A *can* be received into Locations M or N with a status of 5, since neither of these

locations contains inventory with the same lot or reference number as the items being received.

If Item A's Active field were No, it could be received into Locations L, M, or N. In this case, Item A's status would change to the default status for the location—2 for Location L, 3 for Location M, 4 for Location N.

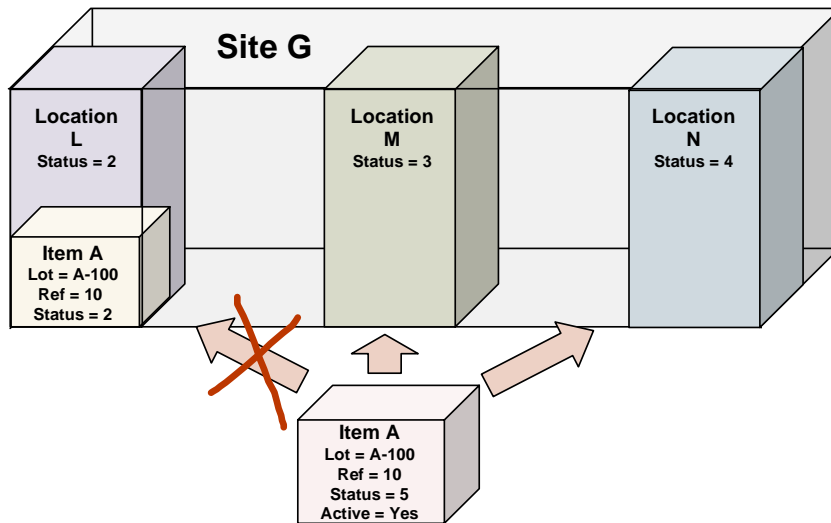

Fig. 5.7
Inventory Status
Example

Using Work Order Batch Control

Batch numbers group and categorize work orders. Use batch control to assign batch numbers to work orders for compliance reporting and traceability. You can assign the same batch number to a group of work orders run through a single manufacturing process. You can assign one batch number per work order receipt session.

Batch traceability is a single-level function. It identifies work orders associated with a batch number. Lot and serial numbers are used to identify, report on, and trace inventory transactions. A lot number is unique to a given finished product or collection of components that make up a finished product. Use lot traceability to identify work order components. A batch number cannot be used for scheduling, planning, or shop floor reporting.

Tip
If you have multiple batches on a single work order, use a different receipt for each batch.

Example A pharmaceutical manufacturer makes acetaminophen powder in large quantities. Each run results in a batch of acetaminophen powder ready for processing into tablets—a batch with an assigned number that uniquely identifies its origin. This batch is the tablet processing source that is packaged in various sized bottles, each labeled with a lot number. The lot number uniquely identifies the item in inventory, traceable by work order receipt, which in turn uniquely identifies the work order and its batch number.

Batch Control Work Flow

Figure 5.8 shows a typical work flow for setting up and managing batches.

Fig. 5.8
Batch Control
Work Flow

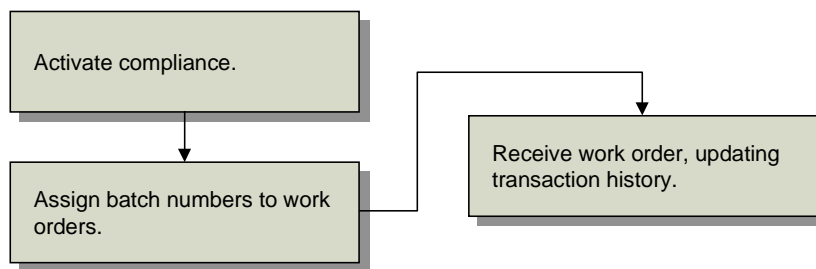

Once compliance has been activated, you can assign batch numbers to work orders directly in Work Order Maintenance or use Work Order Attribute Maintenance (1.22.4). When the work order is received, the batch number is stored in the inventory transaction history file for later reporting.

Assigning Batch Numbers to Work Orders

You will probably assign the batch number when you assign work order attributes during work order creation. You can also use Work Order Attribute Maintenance (1.22.4) to assign numbers.

When you receive the items into inventory with Work Order Receipts (16.11) or Work Order Operation Backflush (16.19), batch numbers are recorded in transaction history.

You can review batch numbers using:

- Transaction Detail Inquiry (3.21.1)
- Reports on the Work Order Reports Menu (16.3)
- Reports on the Lot/Serial Number Menu (3.22)

The programs listed in Table 5.5 use or list batch numbers.

| Menu | Number |
|-----------------------------------|--------|
| Transaction Detail Inquiry | 3.21.1 |
| Lot Transactions by Date Browse | 3.22.1 |
| Lot Actual Bill Inquiry | 3.22.3 |
| Lot Where-Used Inquiry | 3.22.4 |
| Work Order Batch Browse | 1.22.9 |
| Work Order by Order Report | 16.3.1 |
| Work Order by Item Report | 16.3.2 |
| Work Order Status Report | 16.3.3 |
| Work Order History Report | 16.3.6 |
| Work Order Release Print | 16.6 |
| Multiple Work Order Release Print | 16.7 |
| Work Order Split | 16.9 |

Table 5.5
Programs Using
Batch Numbers

Changing Inventory Detail Records

Use Multi-Lot Inventory Detail Update (1.22.19) to change assay %, grade, status, and expire date attributes for a particular item number and lot/serial combination.

Warning Use this feature with caution. The only way to restore old inventory attribute values is to reassign them using this update. If you change all values for a record type to a new value, you cannot recover the original values.

Assay %, grade, expire date, and inventory status can have field security implemented to limit access to any or all of the fields. Use Field Security Maintenance (36.3.4) to enter the names of fields you need to restrict. Users must have explicit authority to access secured fields.

Use the following procedure to update inventory detail records:

- 1 Choose Multi-Lot Inven. Detail Update (1.22.19) from the Compliance Menu.

Fig. 5.9
Multi-Lot Inven.
Detail Update
(1.22.19)

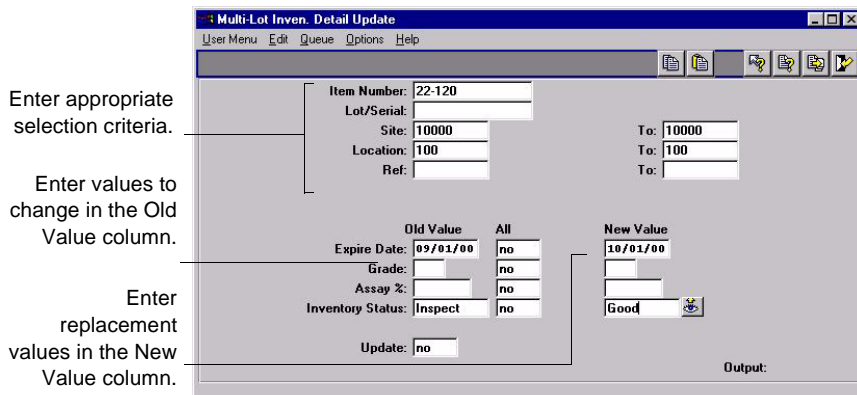

- 2 Enter a value in Item Number. The first lot number displays if inventory exists for this item.
- 3 Use the lot number that displays, enter a new lot number, or clear the Lot/Serial field to update items with blank lot/serial numbers.
- 4 Enter, singly or by range, sites, locations, and references for which you have access privileges.

Note Leaving Site, Location, or Ref blank changes inventory attributes for all sites, locations, and lot references.

- 5 Enter old attribute values, set the All fields, and enter new attribute settings in the lower half of the frame.

Old Value. Enter the value to be changed.

All. If Old Value is blank and All is Yes, all values are changed to New Value. If Old Value is blank and All is No, only blank values are changed to the New Value. The field defaults to No. You can change it to Yes only when Old Value is blank.

New Value. Enter the replacement value for the field.

- 6 Set Update to No and run the program as a report first to make sure you have entered the correct values.

- 7 When you are satisfied with the new values and the item, lot, and site data listed on the report, change Update to Yes and run the program again.

Using Lot Control

You can use lot control features even if Compliance Active is No in the Compliance Control File. Table 5.6 lists lot control features.

| Feature | Description |
|---------------------------------------|--|
| Lot Control Level | Controls enforcement of unique lot numbers. Lot Control Level is a database-level setting. See “Setting Up Compliance” on page 136 and “Deciding on Lot Control Level” on page 154 for more information. If you set Lot Control Level to 0, all lot controls are turned off. |
| Work Order Attribute Lot Number Field | You can enter the lot number in the Work Order Attributes frame when Single Lot is No. See “Defining Inventory Attributes” on page 139 for more information. |
| Lot Groups and Auto Lot Numbering | Define lot groups to assign lot numbers to work orders and purchase orders automatically. See “Automatic Lot Numbering” on page 156 for more information. |
| Single Lot Receipts | Restrict receipts to a single lot, with separate settings for work orders, purchase orders, and repetitive transactions. See “Single Lot per Receipt” on page 159 for more information. |
| Expired Inventory Management | Manage expired inventory transactions. See “Expired Inventory Transactions” on page 161 for more information. |
| Supplier Lot Numbering | Enter supplier lot numbers on purchase order receipts. See “Supplier Lot Numbers” on page 160 for more information. |
| Reports by Lot Number | Make reports using lot numbers as an index. |

Table 5.6
Lot Control
Features

When implementing lot control, be aware of the following restrictions:

- Lot control cannot enforce lot uniqueness across multiple databases. Multiple-database customers should integrate policies to maintain lot number uniqueness for each database.
- Lot numbers cannot be reused. If you make an error during lot number assignment, delete the record for that lot number in Lot Master Maintenance (1.22.1), and then reassign it.

- The system cannot correct duplicate lot numbers assigned prior to lot control activation. Delete duplicate lot numbers using Lot Master Delete/Archive (1.22.23).

Lot Control Work Flow

Figure 5.10 shows a typical work flow for setting up and managing lots.

Fig. 5.10
Lot Control
Work Flow

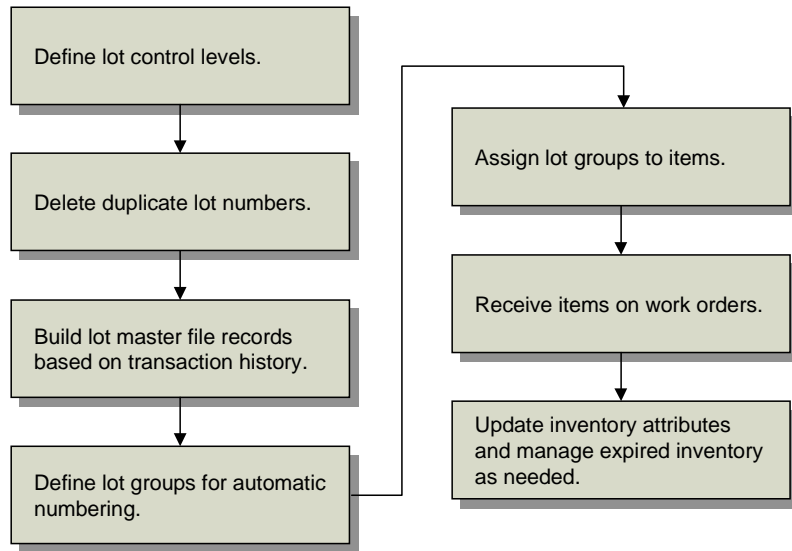

To implement lot control, define defaults in the Compliance Control File for purchase orders, work orders, and repetitive. Then delete any existing duplicate lot numbers using Lot Master Delete/Archive (1.22.23). Use Lot Master File Build (1.22.22) to create lot master file records for all lots referenced in transaction history.

Then define the lot groups needed to generate automatic numbers using Lot Group Maintenance (1.22.13). When the groups have been established, associate them with the appropriate items using Item Inventory Data Maintenance (1.4.5) or Item Master Maintenance (1.4.1).

When items are received on work orders, purchase orders, or repetitive orders, the system generates lot numbers automatically. You can update inventory attributes and manage expired inventory as needed using

Multi-Lot Inventory Update (1.22.19) or Inventory Detail Maintenance (3.1.1).

Lot Control Relationships

The settings described in Figure 5.11, along with the auto-lot settings in Item Master Maintenance (1.4.1), affect lot numbering on several levels.

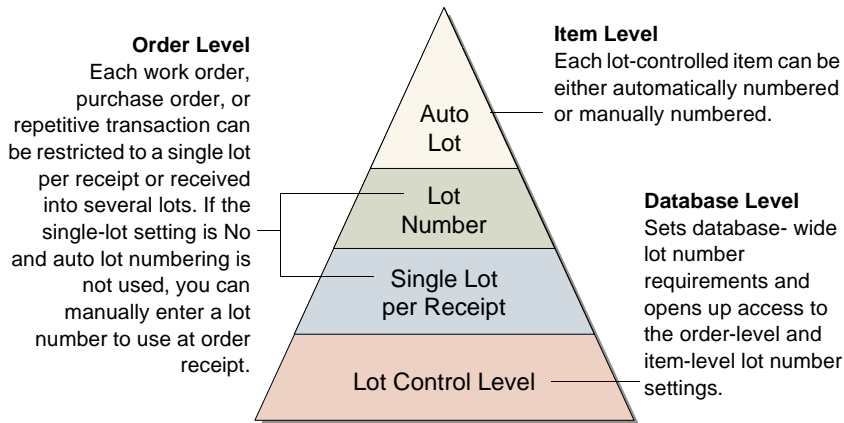

Fig. 5.11
Lot Control Hierarchy

Lot Control Level

This database-level setting is the most straightforward to employ. If you want to use single lot per receipt settings, Lot Control Level must be 1 or 2. If you do not want to use either of these features, you can still use Lot Control Level to control lot number uniqueness for each item (level 1) or across all items in inventory (level 2).

Single Lot per Receipt and Lot Number Field

If you select level 1 or level 2 lot control, then you can use single-lot settings. You can have a different default setting for work orders, purchase orders, and repetitive transactions. Further, the single-lot setting can be changed for each order at the time of receipt. A receipt lot number can be specified in the Work Order Attributes frame when the single-lot setting is No and auto lot numbering is not used.

Auto Lot Numbering

Automatic lot numbering works with any lot level setting. Since automatic lot numbering is set for each item, you can choose to have some items auto numbered and some not.

Deciding on Lot Control Level

Table 5.7 shows five different ways of combining lot control features.

Table 5.7
Lot Control
Settings

| Example | Lot Control Level | Single Lot | Lot No. | Auto Lot No. | Effect |
|---------|-------------------|------------|---------|--------------|---|
| 1 | 0 | – | – | Y | When Lot Control Level is 0, none of the lot control features work. |
| 2 | 1 | Y | – | Y | Items with the same item number cannot have the same lot number; orders are restricted to a single lot by default, the lot number field in work order attributes is inaccessible, and the item is auto numbered. |
| 3 | 2 | Y | – | Y | Lot numbers across all items must be unique. The remainder is the same as example 2. |
| 4 | 1 | N | + | Y | Items with the same item number cannot have the same lot number; orders are not restricted to a single lot by default, the item is auto numbered, and the lot number value in work order attributes is set by the system and cannot be changed. |
| 5 | 2 | N | + | N | Lot numbers across all items must be unique; orders are not restricted to a single lot by default, the lot number field in work order attributes is accessible, and the item is not auto numbered. |

Building the Lot Master File

You must run Lot Master File Build (1.22.22) whenever:

- Lot Control Level is changed from 0 to either 1 or 2.
- Archived records are loaded back into the Inventory Transaction History file.

Lot Master File Build creates lot master file records based on inventory transaction history. These records represent a historical list of all lot and serial numbers used in MFG/PRO eB. Whenever you assign a new lot or serial number and Lot Control Level is 1 or 2, the system automatically updates the lot master file.

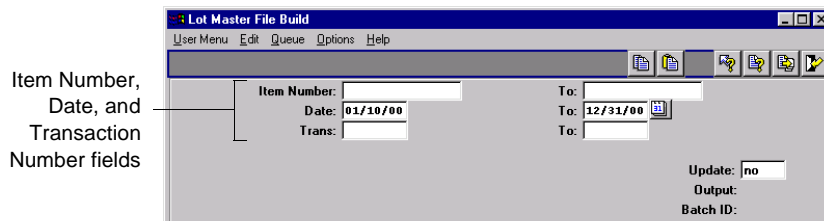

Fig. 5.12
Lot Master File
Build (1.22.22)

You can enter any combination of item number, date, and transaction ID ranges. Before updating the database, set Update to No to generate a listing of changes that will be made. Review the listing to verify that it is correct. Then rerun the program with Update set to Yes.

Modifying the Lot Master File

Use Lot Master Maintenance (1.22.1) to manually add, modify, or delete lot master records. Adding records is not recommended, since the records created with this program are not associated with an order, limiting the traceability.

This function is typically used to add additional data. Many user-defined fields are provided to support custom reporting requirements.

Fig. 5.13
 Lot Master
 Maintenance
 (1.22.1)

Item Number
and Lot/Serial
fields

| | |
|---|-------------------|
| Item Number: 88-4000 | PLASTIC PELLETS |
| Lot/Serial: 44 | MIL-999-001 |
| Order Number: 1004 | |
| Line/ID: 1007 | |
| Expired Inv Trans: <input type="text"/> | |
| Lot UM: <input type="text"/> | Created: 06/08/98 |
| Lot UM Conversion: 1.0000 | User ID: hme |
| Comments: no | |

Specify an item number and lot/serial number. When you press Go, the system displays the order number and line or ID that created the lot or serial number. The date the record was created and the ID of the user creating the record also display.

You can update the following fields:

Expired Inv Trans. An inventory transaction type allowed for executing transactions on expired inventory for this item and lot number.

Lot UM. An alternate unit of measure for this specific lot. This field is for reference only.

Lot UM Conversion. A factor for converting the Lot UM to the item unit of measure. This field is for reference only.

Automatic Lot Numbering

Use Lot Group Maintenance (1.22.13) to create lot groups defining the format for automatic lot numbering. You can restrict lot groups to individual sites or they can apply to all sites. Assign lot groups to items in Item Master Maintenance (1.4.1), Item Inventory Data Maintenance (1.4.5), or Item Master Copy (1.4.12).

If a lot group record is altered or removed after lot numbers have been generated, the continuity of lot numbers will be broken. Additionally, automatically generated lot numbers are not recycled if they are not used at the time they are assigned. It is possible for gaps to appear in the sequencing of auto lot numbers if, for example, a receipt transaction is canceled before inventory is received.

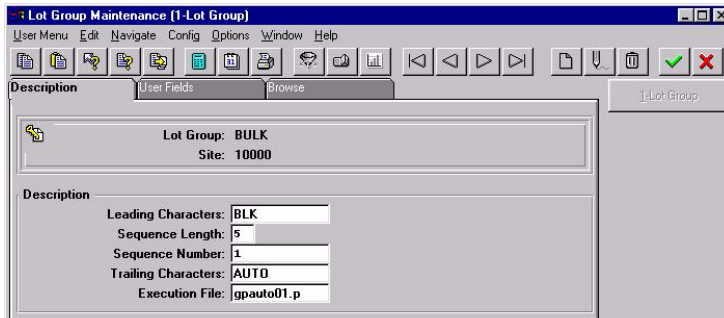

Fig. 5.14
Lot Group
Maintenance
(1.22.13)

Lot Group. Assign a name to the automatic lot numbering format. Name can be up to eight alphanumeric characters.

Site. Enter a value if you want this lot group to be used at one site only. Leave blank if the lot group can be applied to any site.

Leading Characters. Enter up to 12 characters to be placed at the beginning of the lot number. Can be left blank.

Sequence Length. Enter a number between 5 and 10. This is the length of the numeric portion of the automatic lot numbers.

Sequence Number. The default is 1. Enter the first number to be used in automatic lot numbering. The lot number consists of this number, plus leading and trailing characters.

The smallest number available for assignment is 00001 and the largest is 999999999. If you are using a six-digit sequence length, you may want to start automatic lot numbers with 100000 instead of 1. This number increments by 1 when numbers are assigned.

Trailing Characters. Enter up to 12 characters to be placed at the end of the lot number. Can be left blank.

Execution File. The program to execute when assigning automatic lot numbers. The default is `gpauto01.p`, the standard program supplied with MFG/PROeB. You can create custom programs to assign lot numbers based on your own requirements.

Tip
The lot number, including leading characters, sequence number, and trailing characters, can be up to 18 characters long.

Assigning Lot Groups to Items

Use one of the item maintenance programs to set up items for automatic lot numbering:

- Item Master Maintenance (1.4.1)
- Item Inventory Data Maintenance (1.4.5)
- Item Master Copy (1.4.12)

Fig. 5.15
Item Master
Maintenance
(1.4.1)

The screenshot shows the 'Item Master Maintenance' window with the following data:

| Item Number: 88-4000 | | Description: PLASTIC PELLETS | |
|----------------------|------------------|------------------------------|-------|
| UM: KG | | MIL-999-001 | |
| Item Data | | | |
| Prod Line: 4000 | Item Type: RAW | Drawing: 88-4000 | |
| Added: 12/02/96 | Status: AC | Rev: AA | |
| Design Group: | Group: RAW | Drawing Loc: | Size: |
| Promo Group: | Price Break Cat: | | |
| Item Inventory Data | | | |
| ABC Class: | | Avg Int: | 90 |
| Lot/Serial Control: | L | Cyc Cnt Int: | 120 |
| Site: | 10000 | Shelf Life: | |
| Location: | BB | Allocate Single Lot: | no |
| Location Type: | | Key Item: | no |
| Auto Lot Numbers: | yes | PO Rcpt Status: | |
| Lot Group: | Bulk | WO Rcpt Status: | |
| Article Number: | | Active: | no |
| | | Active: | no |

Annotations on the left side of the form:

- Item must be lot controlled. (points to Lot/Serial Control: L)
- Enable automatic numbers and define format. (points to Auto Lot Numbers: yes)

Three fields affect automatic lot numbers:

Lot/Serial Control. Automatic lot numbering only works with lot-controlled items (set to L). It does not work with serial-controlled items.

Auto Lot Numbers. Yes activates automatic lot numbering for this item if L is selected in Lot/Serial Control.

Lot Group. An optional lot group format. If Lot Group is blank, Lot/Serial Control is L, and Auto Lot Numbers is Yes, work orders are assigned a lot number equal to the Work Order ID. However, lot numbers must be entered manually on purchase order and repetitive receipts in this case.

▶ See “Automatic Lot Numbering” on page 156.

Creating Automatic Lot Numbers

When receipts are created for purchase orders and work orders that contain items set up for automatic lot numbering, the system generates a lot number according to the Lot Group format assigned to the item. The lot number cannot be changed. The following programs assign automatic lot numbers:

- Purchase Order Receipts (5.13.1)
- RTS Receipts (11.7.3.13)
- Work Order Receipt (16.11)
- Work Order Receipt Backflush (16.12)
- Work Order Operation Backflush (16.19)
- Repetitive Labor Transaction (18.14)
- Backflush Transaction (18.22.13)
- Move Transaction (18.22.19)

Note Rework and expense work orders cannot be assigned automatic lot numbers.

Single Lot per Receipt

Receipts can be restricted to a single lot number by default on work orders, purchase orders, and repetitive orders, based on three settings in the Compliance Control File (1.22.24):

- Single Lot Per WO Receipt (work order receipt)
- Single Lot Per PO Receipt (purchase order receipt)
- Single Lot Per REPET Receipt (repetitive receipt)

To use single lot receipts, Lot Control Level must be 1 or 2 and Lot/Serial Control must be L or S for the item being received.

If these criteria are met and Single Lot is Yes on the order or line being received:

- Items received in the same transaction must have the same lot number.
- Each receipt transaction requires a new lot number.

Tip

The single lot restriction can also be selected during order receipt, regardless of the setting in the Compliance Control File.

Set Single Lot to No to allow the same lot number to be used for multiple receipts. The single lot restriction works the same way for all three order types, so you can adapt the settings to your needs.

▶ For more information, see “Automatic Lot Numbering” on page 156.

Note When Auto Lot Numbers is Yes and a lot group is specified in the item master, the system automatically increments the numeric portion of the lot number for each successive receipt against the same order or line. This means that you cannot receive the same lot in multiple receipt transactions or receive multiple lots in the same transaction, regardless of whether Single Lot is Yes.

During order entry, you can modify the default value of Single Lot in any of the following programs:

- Purchase Order Maintenance (5.7)
- Blanket Order Maintenance (5.3.1)
- Work Order Maintenance (16.1)
- Work Order Attribute Maintenance (1.22.4)
- Repetitive Labor Transaction (18.14)
- Backflush Transaction (18.22.13)
- Move Transaction (18.22.19)

Supplier Lot Numbers

The Supplier Lot field is a reference field for entering supplier lot numbers in Purchase Order Receipts (5.13.1).

Fig. 5.16
Purchase Order Receipts (5.13.1)

| Ln | Item Number | UM | Qty | Open UM | Receipt Qty | UM | Project | Due | T |
|----|-------------|----|-----|---------|-------------|----|---------|----------|---|
| 1 | 486-66 | EA | 1.0 | EA | 0.0 | EA | | 04/28/95 | |

Line: 1 UM: EA Site: 11000 Loc:
 Quantity: 0.0 ID: Lot/Ser:
 Packing Qty: 0.0 WO Op: 0 Ref:
 Cancel B/O: no Supplier Lot: SUP-100598
 Item Number: 486-66 Multi Entry: no Chg Attribute: no
 Supplier Item: Cmnts: no

Supplier Lot field

One supplier lot number can be assigned for each lot received. For example, if you have two supplier lot numbers, you cannot receive both into the same internal lot number. There are two alternative ways to handle this situation:

- Receive each supplier lot number to a different location. Then you can assign the same internal lot number to each.
- Receive the first supplier lot and complete the receipt transaction; then perform a second receipt.

To review and report on supplier lot numbers, use the Supplier Lot field in the following inquiries:

- Transactions Detail Inquiry (3.21.1)
- Lot Where-Used Inquiry (3.22.4)

Expired Inventory Transactions

When lot-controlled items expire, you may want to remove them from inventory. In MFG/PROeB, expired inventory cannot be sold or issued for manufacturing. However, for lot-controlled items, you can specify a transaction type that can occur for any expired items in a lot.

Lot Control Level must be 1 or 2 before you can use expired inventory features.

Example If you enter ISS-UNP (Unplanned Issue), the system lets you make an unplanned issue transaction, even though inventory has expired. This is true only for the item number and lot number identified on this Lot Master record.

Use the Expired Inv Trans field in Lot Master Maintenance (1.22.1) to specify this transaction type.

Tip
Inventory is expired if it has an expiration date before today.

▶ See “Setting Up Compliance” on page 136.

▶ See “Modifying the Lot Master File” on page 155.

Managing Component Issues

▶ See “Setting Up Compliance” on page 136.

Compliance provides options for restricting component items issued to work orders to those on the bill of material (BOM) or defined as valid substitutes. You can implement a similar control for receipts of co-product and by-product items.

Component Issue Control

Use the Modify Component Issues field in the Compliance Control File (1.22.24) to control issues to work orders. Set this field to No to require that all items issues are on the work order BOM or are valid substitute items. Choose Yes to allow any item to be issued to the work order.

Valid substitute items are defined in Item Substitution Maintenance (13.19). When Modify Component Issues is No, issues are allowed for those items with valid substitutes.

Co-product/By-product Component Issue Control

Use the Modify Co/By-Product Receipts field in the Compliance Control File to control receipts for co-products and by-products.

- Set this field to No to require all receipts to be valid items or substitute items for a co-product or by-product in a joint work order set.
- Choose Yes to allow any item to be received as an unplanned receipt.

Tip
Items entered through Work Order Bill Maintenance (16.13.1) can be issued to a work order regardless of control file settings.

Managing Controlled Substances

Controlled substance programs, files, and fields do not interfere with functions in other modules.

The functions on the Controlled Substance menu, listed in Table 5.8, are used to record Health Industry Numbers (HIN), National Drug Codes (NDC), Export Control Classification Numbers (ECCN), Harmonized Tariff Codes, Regional Value Content (RVC) values, and Preference Criteria Codes for controlled substances, import/export, and international agreement compliance.

| Menu | Description | Program |
|------------|----------------------------------|-----------|
| 1.22.16 | Controlled Substances Menu | |
| 1.22.16.1 | Controlled Authority Maintenance | clctamt.p |
| 1.22.16.2 | Controlled Authority Inquiry | clctaiq.p |
| 1.22.16.4 | Controlled Customer Maintenance | clctcmt.p |
| 1.22.16.5 | Controlled Customer Browse | clbr003.p |
| 1.22.16.7 | Controlled Site Maintenance | clctsmt.p |
| 1.22.16.8 | Controlled Site Browse | clbr004.p |
| 1.22.16.10 | Controlled Item Maintenance | clctpmt.p |
| 1.22.16.11 | Controlled Item Report | clctprp.p |
| 1.22.16.13 | General License Maintenance | clglimt.p |
| 1.22.16.14 | General License Report | clglirp.p |
| 1.22.16.16 | Individual License Maintenance | clilimt.p |
| 1.22.16.17 | Individual License Master Report | clilirp.p |

Table 5.8
Controlled Substances Menu (1.22.16)

Figure 5.17 shows a typical work flow for setting up and managing controlled substances.

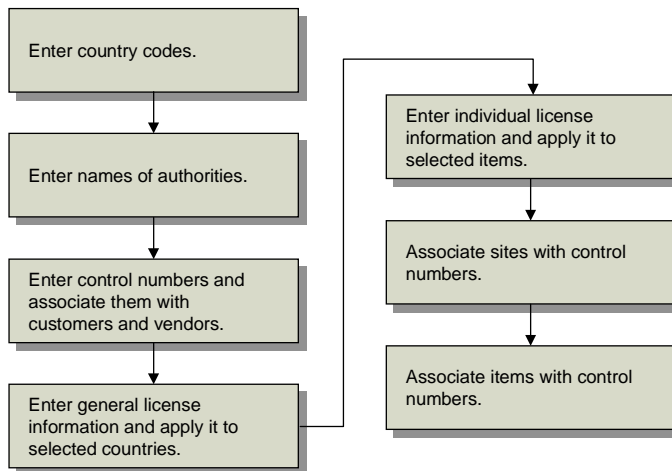

Fig. 5.17
Controlled Substances Work Flow

Entering Country Codes

Tip

Country codes can also be entered in Intrastat Country Code Maintenance (2.22.1.10).

Use Country Code Maintenance (2.13.3.1) to define country codes, including information about a country's membership in international organizations and their DEA status. You can also categorize countries by assigning each one to a country group using a coding system—such as the US Export Administration codes.

Fig. 5.18
Country Code
Maintenance
(2.13.3.1)

The screenshot shows a window titled "Country Code Maintenance" with a menu bar (User Menu, Edit, Queue, Options, Help) and a toolbar. The main area displays the following fields for the country code "FRA":

| | |
|-----------------|--------|
| Country Code: | FRA |
| Name: | France |
| Alternate Code: | FR |
| EC Country: | yes |
| NAFTA Country: | no |
| DEA Country: | no |
| GATT Country: | no |
| Country Group: | |
| Country Type: | |
| Comments: | no |

Country Code. Enter up to three alphanumeric characters identifying a country.

Name. Enter the complete name of the country.

Alternate Code. If needed, specify an alternate code for creating subsets of country codes or for additional sorting on reports.

EC Country, NAFTA Country, DEA Country, GATT Country. For each organization this country belongs to, enter Yes in the appropriate field.

Country Group, Country Type. If needed, enter a group and type for further categorizing countries.

Entering Authority Codes

Enter authorities in Controlled Authority Maintenance (1.22.16.1). These authorities are assigned, along with country codes, to customers, sites, and items.



The screenshot shows a window titled "Controlled Authority Maintenance" with a menu bar (User Menu, Edit, Queue, Options, Help) and a toolbar. The main area contains the following fields:

- Authority: US_COM
- Name: U.S. Commerce Commission
- Type: Export
- Group: (empty)
- Comments: no

Fig. 5.19
Controlled
Authority
Maintenance
(1.22.16.1)

Authority. Enter a descriptive acronym or short name, up to eight characters long. For example, enter DEA for Drug Enforcement Administration or WHO for World Health Organization.

Name. Enter the full name for the authority.

Type, Group. Enter values to further categorize authorities on reports.

Entering Control Numbers for Customers and Sites

Use Controlled Customer Maintenance (1.22.16.4) to associate control numbers with customers and vendors. Use Controlled Site Maintenance (1.22.16.7) to associate control numbers with sites. These two programs are the same except that you enter an address code in the first and a site code in the second.

These programs can be used to store many types of codes, such as codes associating a DEA number with a customer, foreign tax identification numbers, or other numbers associated with customers, suppliers, or sites.



The screenshot shows a window titled "Controlled Customer Maintenance" with a menu bar (User Menu, Edit, Queue, Options, Help) and a toolbar. The main area contains the following fields:

- Country: USA
- Authority: US_Com
- Address Code: 01000000
- Control Number: 387-CD-3983993
- Start Date: 01/01/98
- End Date: 12/31/98
- Comments: no

Fig. 5.20
Controlled
Customer
Maintenance
(1.22.16.4)

Enter the country code, authority, and address or leave Country code blank if this record applies to all countries. Then specify the control number associated with the address. In Figure 5.20, the control number could be the customer’s export license number.

Entering Control Numbers for Items

Use Controlled Item Maintenance (1.22.16.10) to associate control numbers with items.

This programs can be used to store many types of codes, such as codes associating DEA registration numbers with items, foreign tax identification numbers, or other codes associated with items.

Fig. 5.21
Controlled Item Maintenance (1.22.16.10)

Enter the country code and authority or leave Country blank if this record applies to all countries. Then specify the control number associated with one or more items.

Every product that is exported from the United States requires an Export Control Classification Number (ECCN). These are defined in the U.S. Commerce Control List.

Other fields apply to common control requirements or can be used as needed.

Status. Enter a user-defined status. If your company requires Harmonized Codes for NAFTA, use this field to enter a Producer Status.

Class. Enter a user-defined class. If your company requires National Drug Code (NDC) numbers, use this field to enter drug classes, such as class 1, 2, or 3. If your company is NAFTA compliant, use this field to enter a Regional Value Content (RVC) value.

Preference Criteria. Enter a user-defined preference criteria. If your company is NAFTA compliant, use this field to enter appropriate codes.

Address Code. Enter up to three addresses associated with the item, such as the primary ship-from site or primary exporter.

Originating Country. Enter the code for the country where this item is usually manufactured.

Originating Percent. Enter the percentage of the item that is usually manufactured in the Originating Country.

Entering General License Information

Enter general license information using General License Maintenance (1.22.16.13). General licenses are typically import and export licenses that apply to a country or a group of countries. You can associate licenses with a control number.

Country, Authority, License Number, and Control Number/ECCN fields.

| | |
|---------------------|----------------|
| Country: | USA |
| Authority: | US_COM |
| License Number: | 383883-CD-3928 |
| Control Num / ECCN: | 44 |
| Country Groups: | |
| Start Date: | 01/01/98 |
| End Date: | 12/31/98 |
| Max Amount: | 10,000.00 |
| Total Amount: | 40,000.00 |
| Max Quantity: | 3,000 |
| Total Quantity: | 50,000 |
| Currency: | USD |
| Comments: | no |

Fig. 5.22
General License Maintenance
(1.22.16.13)

Enter the country code, authority code, and license number. Leave Country blank if this license applies to all countries. Enter the control number or ECCN number, defined in Controlled Item Maintenance.

If needed, enter country groups, start and end dates, maximum per shipment values, annual shipment values, and currency for this item.

Tip
The start and end dates determine the effective dates of the license.

Entering Individual License Information

Enter individual license information using Individual License Maintenance (1.22.16.16). Individual licenses are typically import and export licenses that apply to individual items.

Fig. 5.23
Individual License
Maintenance
(1.22.16.16)

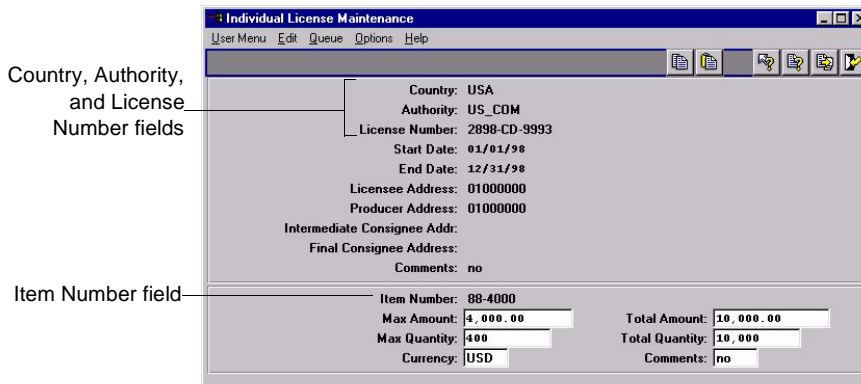

Enter the country code, authority code, and license number. Leave Country blank if this license applies to all countries. Specify the start and end dates for the license and the address codes.

Licensee. The company granted the license.

Producer. The manufacturer of the product under license. Use this field if the license applies to a single item.

Intermediate Consignee. An intermediate distribution point.

Final Consignee. A distribution point that is the final destination.

Enter an item number if this license is for one item. Specify maximum per shipment values, annual shipment values, and currency for this item.

Addresses

MFG/PROeB enables you to associate addresses and other information with address codes that can be used throughout the system.

| | |
|--|------------|
| <i>Introduction</i> | 170 |
| <i>Setting Up Company Addresses</i> | 173 |
| <i>Setting Up Salesperson Addresses</i> | 174 |
| <i>Setting Up Customer Addresses</i> | 175 |
| <i>Customer Data</i> | 177 |
| <i>Adjusting Credit Limits</i> | 179 |
| <i>Setting Up Supplier Addresses</i> | 180 |
| <i>Setting Up Employee Addresses</i> | 181 |
| <i>Setting Up Carrier Addresses</i> | 181 |
| <i>Setting Up Customer/Supplier Bank Addresses</i> | 182 |
| <i>Setting Up Credit Terms and Trailer Codes</i> | 184 |
| <i>Setting Up Freight Charges</i> | 189 |
| <i>Changing or Merging Address Codes</i> | 194 |

Introduction

Addresses functions enable you to enter a wide range of records used elsewhere in MFG/PRO eB—from customers and suppliers to credit terms and freight codes.

Table 6.1 lists programs in the Addresses/Taxes menu and shows where address codes are used.

Table 6.1
Addresses/Taxes
Menu (2)

| Menu | Name | Where Used |
|------|-------------------------------|---|
| 2.1 | Customers Menu | Sales Orders/Invoices, Customer Schedules, Accounts Receivable, and Service/Support Management modules. |
| 2.3 | Suppliers Menu | Purchasing, Supplier Schedules, Accounts Payable, and Service/Support Management modules. |
| 2.5 | Salespersons Menu | Sales Orders/Invoices, Accounts Receivable, and Service/Support Management modules. |
| 2.7 | Employees Menu | Service/Support Management, Shop Floor Control, Repetitive. |
| 2.9 | Address List Type Maintenance | Address maintenance. |
| 2.10 | Address List Type Browse | Address maintenance. |
| 2.11 | Address Code Change | Address maintenance. |
| 2.12 | Company Address Maintenance | System reports and screens. Bill-to/ship-to addresses in Purchasing. Ship-to address in Accounts Payable. Printed on outgoing documents such as sales orders, invoices, service contracts, and statements. Addresses for sites required for Global Tax Management (GTM) and Enterprise Material Transfer (EMT). |
| 2.13 | Global Tax Management (GTM) | See <i>Section 2, “Global Tax Management,” beginning on page 241.</i> |
| 2.17 | Carriers Menu | Shipping functions. |
| 2.18 | Shipping Group/Document Menu | Shipping functions. For information on shipping groups, see <i>User Guide Volume 2: Distribution.</i> |

| Menu | Name | Where Used |
|------|---------------------------------|---|
| 2.19 | Credit Terms/Trailer Codes Menu | Transactions for sales, purchasing, service/support, accounts payable, and accounts receivable. |
| 2.20 | Freight Charges Menu | Transactions for sales, purchasing, service/support, accounts payable, and accounts receivable. |
| 2.21 | Customer/Supplier Banks Menu | Accounts Payable and Receivable. |
| 2.22 | Intrastat | See Chapter 7, "Intrastat," on page 197. |
| 2.24 | Addresses/Taxes Control File | Address functions. |

Except for employee addresses, all addresses are stored in the same address file in the database, ensuring consistency of information. An eight-character address code assigned to each address is the key identifier of that address.

An address code can be associated with different address types. For example, an employee address code can be used as a salesperson address for sales and commission reporting, and as a supplier address for reimbursement of expenses.

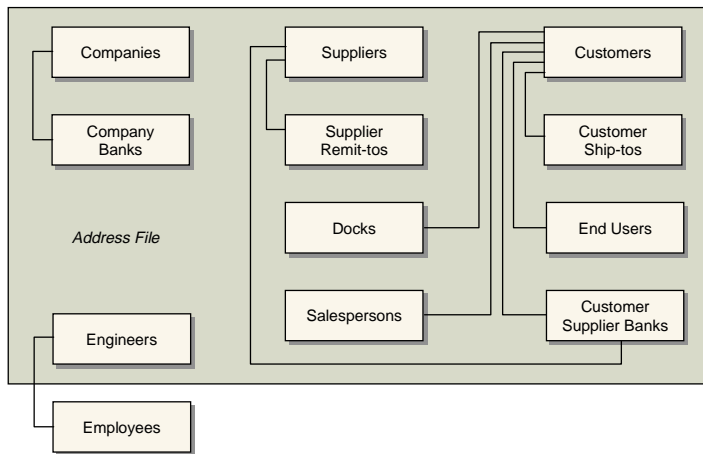

Fig. 6.1
Address File
Relationships

The system stores information on customers, suppliers, and salespersons in master files, using address codes as an index. A cross-reference file (ls_mstr) describes the links between these files and the centralized address file.

Address List Types

Since addresses are stored in a common file, the system automatically assigns each a list type code. The list types in Table 6.2 are reserved for use by the system.

Table 6.2
Address List Types

| List Type | Originating Function |
|-----------|------------------------------------|
| C/S_Bank | Customer/Supplier Bank Maintenance |
| Carrier | Carrier Maintenance |
| Company | Company Address Maintenance |
| Customer | Customer Maintenance |
| Dock | Dock Maintenance |
| Enduser | End User Address Maintenance |
| Engineer | Engineer Maintenance |
| Our_Bank | Bank Maintenance |
| Remit-to | Supplier Remit-to Maintenance |
| Ship-to | Customer Ship To Maintenance |
| Slsprsn | Salesperson Maintenance |
| Supplier | Supplier Maintenance |

To group addresses in other ways, you can manually assign an unlimited number of additional list type codes to any address. Use Address List Type Maintenance (2.9) to create your own address groups.

List types determine which addresses are included in look-up browses and reports. For example, when presenting look-up information in the Customer field of Sales Order Maintenance (7.1.1), the system includes only addresses with the list type Customer.

Setting Up Company Addresses

Use Company Address Maintenance (2.12) to set up addresses for each of your company sites.

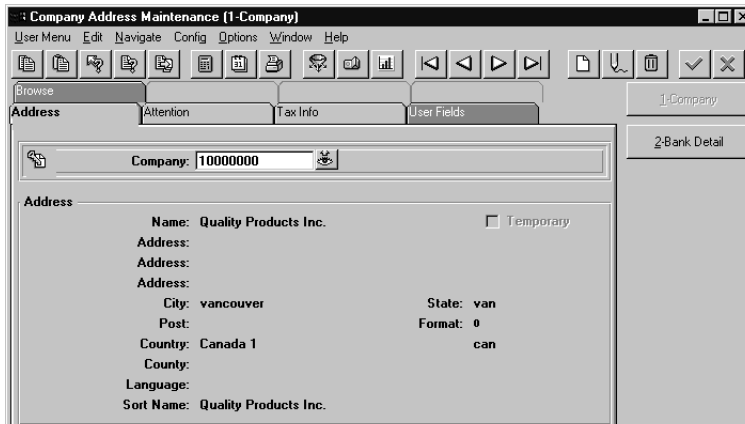

Fig. 6.2
Company Address
Maintenance (2.12)

Your company name and address automatically prints on quotes, orders, and invoices. To display your company name and address on menus and reports, set up the following special address codes:

- *~screens* defines the company name that appears on all menus.
- *~reports* defines the company name that is printed at the top of all reports.

Company Banks

Use Company Address Maintenance to associate banks with company addresses. Bank information prints on Accounts Receivable drafts and Accounts Payable check forms. Bank information includes mailing address, account type, branch code, and tax IDs. If the account is for electronic funds transfer, an EDI number is specified.

▶ See “Setting Up Customer/Supplier Bank Addresses” on page 182.

Company Addresses for Purchase Orders

Tip

Take care to set up company address codes and site codes differently to avoid unintentional matches between them.

Use Company Address Maintenance (2.12) to enter a company's bill-to and ship-to addresses for purchasing. If the site code on a purchase order line corresponds to a company address code, that company address is used as a ship-to address when printing purchase orders. When using distributed order processing, this allows a single purchase order to be printed for multiple ship-to addresses.

Company Address and GTM

Global Tax Management calculates taxes based on company address rather than site. Set up each site with a company address record that uses the same address code as the site code. To provide defaults for missing address codes, set up a special address code called *~taxes*.

Setting Up Salesperson Addresses

Tip

Use Sales Analysis functions to establish monthly quotas and generate quota reports. See *User Guide Volume 2: Distribution*.

Use Salesperson Maintenance (2.5.1) to set up salesperson codes. For each salesperson, specify a default commission percentage and a user-defined territory code. Enter detailed commission percentages for product lines and/or customers. Commission reports calculate amounts from net sales prices or gross margins (net price less standard cost) on posted invoices. Commissions are not reported from debit/credit memos.

Fig. 6.3
Salesperson
Maintenance
(2.5.1)

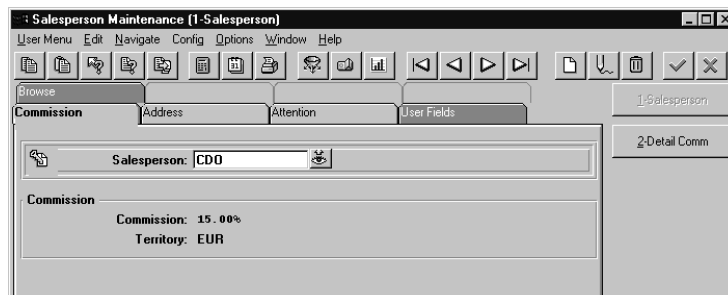

Set up salesperson codes before setting up customer codes. Up to four default salesperson codes and commission percentages can be associated with each customer. These associations are used as defaults in Sales Quotations, Sales Orders/Invoices, Service/Support Management, and Accounts Receivable.

Use Salesperson Payments Report (2.5.16) to review paid invoices and unapplied payments, sorted by salesperson.

Setting Up Customer Addresses

Customer addresses are used for sales quotations, sales orders, invoices, and in accounts receivable. They are also used for service/support documents such as calls, contracts, and return material authorizations (RMAs). Values associated with customer addresses determine default values in programs that reference customers, as well as determining how customer transactions are processed. For example, Credit Hold determines whether orders for a customer are automatically put on credit hold.

A sales order or sales quotation references three customer addresses. The addresses can be the same or each can be different.

- *Sold-to customer.* The customer placing the order.
- *Bill-to customer.* The customer paying the invoice.
- *Ship-to customer.* The customer receiving the order.

Many sales order fields derive defaults from customer address records. Sales order header information such as default credit terms and currency are determined by bill-to customer, as is trailer information such as accounts receivable accounts. Other fields default from the sold-to customer, unless a customer record was entered for the ship-to address for the order. These include site, language, taxable status and other tax defaults, salesperson, commission, remarks, ship via, and FOB point.

There are several ways to set up sold-to, bill-to, and ship-to customers, depending on the extent to which they share defaults.

If site, language, price list information, and so on are the same for sold-to and ship-to customers, set up these addresses in one step using Customer Ship-to Maintenance (2.1.13). If the defaults differ, set up the addresses in both Customer Maintenance (2.1.1) and Customer Ship-to Maintenance.

During order entry, the bill-to address defaults to the sold-to unless a different bill-to address is assigned. The ship-to address also defaults to the sold-to. Alternate ship-to addresses can be set up in advance or

entered as needed for one-time drop shipments. There can be more than one ship-to address for a single sold-to or bill-to customer.

Add temporary ship-to addresses during quote or order entry. These are deleted automatically by Closed AR Delete/Archive (27.23) when no open records remain for the ship-to address. Make temporary ship-to addresses permanent in Customer Ship-to Maintenance (2.1.13) by setting Temporary to No.

Fig. 6.4
Customer
Maintenance
(2.1.1)

The screenshot shows a window titled "Customer Maintenance" with a menu bar (User Menu, Edit, Queue, Options, Help) and a toolbar. The main area is divided into two sections: "Customer Address" and "Customer Data".

Customer Address

| | | | | | | | |
|-----------------|--------------------------|--------|---------|-------|-------|---------|---|
| Customer: | 10010001 | | | | | | |
| Name: | Westwood Reliable | | | | | | |
| Address: | Westwood Shopping Center | | | | | | |
| Address: | 77 Sunset Strip | | | | | | |
| Address: | Block B-2 | | | | | | |
| City: | Westwood | State: | CA | Post: | 89029 | Format: | 0 |
| Country: | United States of America | USA | County: | 001 | | | |
| Attention: | Rosetta Stone | [2]: | | | | | |
| Telephone: | 213-923-0293 | Ext: | [2]: | Ext: | | | |
| Fax/Telex: | | [2]: | | | | | |
| Added: 10/09/88 | | | | | | | |

Customer Data

| | | | | | |
|------------|-----------------------------------|-------------------|-------|---------|----|
| Sort Name: | Westwood Reliable | Type: | 1 | | |
| Salespsn1: | JJP | Multiple: | no | Region: | US |
| Ship Via: | GROUND | Currency: | USD | | |
| AR Acct: | 1200 | Dual Pricing Cur: | | | |
| Resale: | 89-02-03 X88P | Site: | 10000 | | |
| Remarks: | STORE HOURS BETWEEN 10:30 AND 5 F | Lang: | | | |

City, State, Province, County. Used for tax calculations. A country code must be specified and is validated.

Format. Enter 0 to have the postal code appear after the city, state, or province. Enter 1 to have the postal code appear before the city, state, or province.

Multiple. Enter Yes to enter up to four salesperson codes.

Type, Region, Class. Enter types and regions to be used for sales analysis reporting. Enter classes to indicate customer priority, as when not all orders can be filled.

Currency/Language. Associate currencies and languages with customers located in different countries. Language codes enable you to access foreign language comments. Define currency codes in Currency Maintenance (26.1) and exchange rates in Exchange Rate Maintenance (26.4).

Site. This is the default ship-from site for this customer. Typically, enter the site closest to the customer.

Customer Data

Set up additional data for each customer. The system uses this information during order entry.

Customer Data

Taxable: no

Price Tbl: []

Disc Tbl: 10

Fixed Price: yes

Class: []

Partial OK: yes

Price and Discount Table. These provide defaults for scheduled orders only. Sales orders use the best pricing model.

Fixed Price. Enter Yes to indicate that prices negotiated with the customer are fixed. Enter No to indicate that prices negotiated with the customer are not fixed. Prices not fixed are subject to batch updates based on changes in price lists.

Class. Enter classes to indicate customer priority. When you cannot fill all orders, items can be allocated by customer class.

Fig. 6.5
Customer Data
Frame

▶ See Chapter 3, “Pricing,” for more details.

Customer Credit Data

Set up credit information for each customer. The system uses this information during order entry.

Customer Credit Data

Credit Limit: 1,000

Disc %: 0.00%

Bill-To: []

Terms: 30

Finance Chg: yes

Last Credit Review: / /

Credit Hold: no

Statement: yes

Last Credit Update: 12/16/94

Credit Rating: 3

Stmt Cycle: 1

High Credit: 1,000

DB Number: []

Dun Letter: yes

High Date: 02/10/94

PO Required: no

Last Payment: []

Last Sale: []

Credit Terms. Assign a credit terms code defining this customer’s normal payment terms.

Credit Hold. Specifies the customer’s credit limit. When an order exceeds the limit, a warning displays. If the Sales Order Control

Fig. 6.6
Customer Credit
Data Frame

▶ See “Setting Up Credit Terms and Trailer Codes” on page 184 for details.

File (7.1.24) requires an order to be put on hold when limits are exceeded, the order's Action Status is set to HD (hold). You cannot print packing lists for an order until credit holds are removed.

Disc %. Enter a discount value if the customer normally receives a total order discount in addition to pricing discounts. If the customer qualifies for a volume discount higher than this, the system uses the volume discount.

Finance Chg. Enter Yes if this customer is subject to finance charges.

Stmt Cycle. Indicate how often statements are printed, such as monthly or quarterly. This is used as a selection criteria when printing dunning letters and calculating finance charges.

Dun Letter. Enter Yes if customer receives dunning letters for past-due invoices.

Last Credit Review. Enter the date of the last review of the customer's credit status.

Last Credit Update. Indicates the last time the customer's credit limit status was updated. This date is automatically updated by Customer Credit Limit Adjustment (2.1.7).

Customer Freight Data

Set up freight information for each customer. The system uses this information during order entry.

Fig. 6.7
Customer Freight
Data Frame

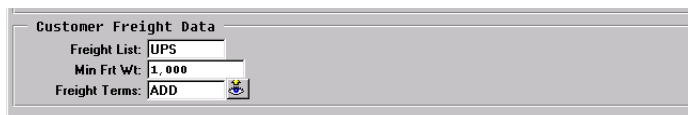

| Customer Freight Data | |
|-----------------------|-------|
| Freight List: | UPS |
| Min Frt Wt: | 1,000 |
| Freight Terms: | ADD |

See "Setting Up Freight Charges" on page 189 for details.

Freight List. Enter a freight list code identifying a set of shipping rates normally used for this customer. This list defaults to the order header for new orders for this customer.

Min Frt Wt. Enter the minimum weight to use with bulk freight lists for this customer. Shipments that weigh less than this amount are charged based on minimum weight, not the actual shipment weight.

Freight Terms. Enter a code identifying how freight charges are typically calculated for this customer.

Other Customer Data

Three other frames display in Customer Maintenance:

- The Address Tax Data frame displays for the input of Global Tax Management data. ▶ See “Customers, Suppliers, and End Users” on page 274.
- The Enterprise Material Transfer Data frame is described in *User Guide Volume 2: Distribution*.
- The Bank Accounts frame in Customer Maintenance is the same as the one in Supplier Maintenance. ▶ See “Setting Up Customer/Supplier Bank Addresses” on page 182.

Adjusting Credit Limits

Use Customer Credit Limit Adjustment (2.1.7) to increase or decrease customer credit limits defined in Customer Maintenance (2.1.1) automatically. Select a range of customers based on address code, region, class, current credit limit, date of last credit review, or date of last credit update.

Adjustment %. Enter a percentage for adjusting the credit of selected customers. Indicate decreases with negative percentages.

Compound/Simple. The system uses one of three methods to calculate a new credit limit amount. N is the number of days since the last time the customer’s credit limit was updated.

| Method | Formula |
|-------------------|--|
| Compound Interest | Old credit limit x (1 + Adjustment % /100)N |
| Simple Interest | Old credit limit x (1 + N x Adjustment % /100) |
| Fixed Interest | Old credit limit x (1 + Adjustment % /100) |

Values entered here determine the method used to adjust credit limit amounts. Table 6.4 identifies the settings required for each method.

Table 6.3
Interest Calculation
Methods

Table 6.4
Calculation of
Credit Limit

| To Choose This Method... | Set Cumulative/ Fixed to... | Set Compound/ Simple to... |
|-----------------------------|--------------------------------|-------------------------------|
| Compound Interest | Cumulative | Compound |
| Simple Interest | Cumulative | Simple |
| Fixed Percentage | Fixed | |

Cumulative/Fixed. Specifies whether the adjustment percentage is a fixed percentage or a cumulative daily percentage, applied to every day since the last credit limit update.

Update Credit Limit. Enter Yes to update the customer’s credit limit and set the last credit update date to the system date in Customer Maintenance (2.1.1). Enter No to review the report without updating the customer record.

Setting Up Supplier Addresses

Set up supplier addresses in Supplier Maintenance (2.3.1) and Supplier Remit-to Maintenance (2.3.13). Supplier addresses are used in Purchasing, Accounts Payable, Service/Support Management, and other functions.

Fig. 6.8
Supplier
Maintenance
(2.3.1)

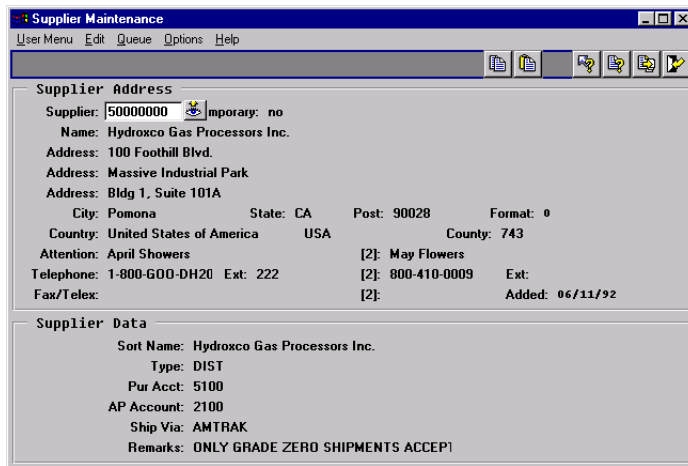

Supplier addresses, like customer addresses, determine default field values and affect how supplier transactions are processed in the system. Remit-to addresses are used when payments created in Accounts Payable

must be sent to an address different from the supplier address. Each supplier can have only one remit-to address.

Setting Up Employee Addresses

Use Employee Maintenance (2.7.1) to enter employee address records. At least one employee record is required for the Shop Floor Control and Repetitive modules. Employee records must be created before defining engineers in the Service/Support Management module.

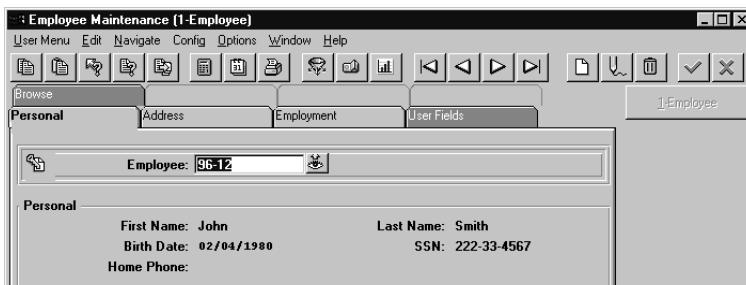

Fig. 6.9
Employee
Maintenance
(2.7.1)

Setting Up Carrier Addresses

Use Carrier Maintenance (2.17.1) to create carrier names and addresses, telephone and FAX numbers, contact names, and the carrier's tax ID on printed shipping documents. Carriers are identified by an address list type of carrier.

A carrier handles the transportation of goods from a shipping site. Typically shipments require a single carrier. However, sometimes a series of carriers is needed. For example, a shipment can be transported by truck to be loaded onto a train, transported by train to be loaded onto a ship, then transported by ship to its final destination.

You can associate a carrier or series of carriers for kind of inventory movement in a shipping group. A carrier cannot be deleted if it is currently in use by any shipment, shipping group, or tax history record.

Fig. 6.10
Carrier
Maintenance
(2.17.1)

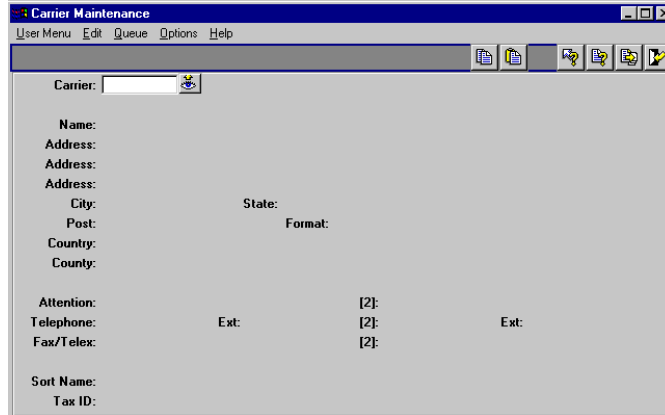

Setting Up Customer/Supplier Bank Addresses

Customer banks are banks your customers use to pay your company. Supplier banks are banks your suppliers use to receive payments from your company.

Use Customer/Supplier Bank Maintenance (2.21.1) to set up customer, supplier, and company bank addresses, specifying any number of accounts for each bank. Specify bank branch codes and begin/end dates for using the accounts on payments. If you transfer funds electronically, record each bank’s mailing address, tax IDs, and EDI IDs.

Fig. 6.11
Customer/Supplier
Bank Maintenance
(2.21.1)

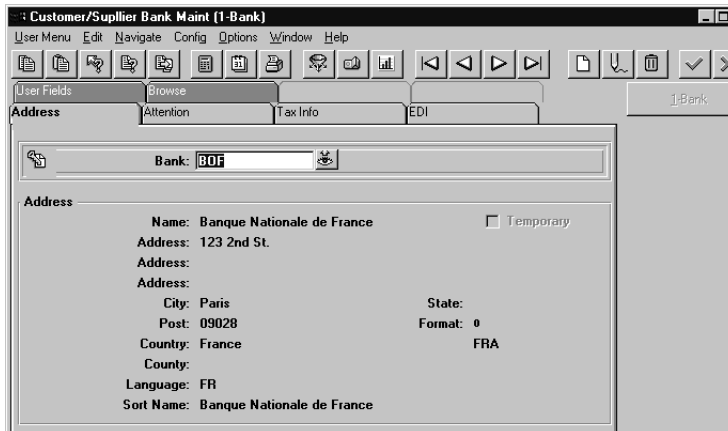

To set up bank addresses to be used in payments:

- 1 Set up bank address information.
- 2 Define bank accounts.

Use Customer/Supplier Bank Maintenance (2.21.1) to set up a record for each supplier bank that receives your EFT payments. This information can be included in the printout or file you send to your bank whenever you process EFT payments. The system assigns customer and supplier banks an address list type of c/s_bank.

Use Customer/Supplier Bank Browse (2.21.2) or Report (2.21.3) to review your setup.

Use Supplier Maintenance (2.3.1) to specify accounts for each supplier bank. Record the bank code, account type, and other information for each account. The first bank (in alphanumeric sequence) is the default supplier bank for each new voucher. Be sure to specify at least one type 1 (ALL) account for each supplier.

Tip

You can also set up customer banks, although these are not used by Accounts Receivable.

Tip

For reference purposes, you can also record customer bank accounts in Customer Maintenance (2.1.1).

| Supplier Maintenance | | | | | | | |
|-----------------------------------|----------------------------|------------|------------------|--------------|------------|----------|---|
| User Menu Edit Queue Options Help | | | | | | | |
| Supplier Address | | | | | | | |
| Supplier: | 5001000 | Temporary: | no | | | | |
| Name: | General Supply Corporation | | | | | | |
| Address: | 720 East College Avenue | | | | | | |
| Address: | Building B-2 | | | | | | |
| Address: | | | | | | | |
| City: | Los Angeles | State: | CA | Post: | 90293 | Format: | 0 |
| Country: | U.S.A. | | 400 | County: | LA | | |
| Attention: | Mr. Richard Avery | [2]: | Mr. Ralph Hutton | | | | |
| Telephone: | 213-923-0392 | Ext: | | [2]: | | Ext: | |
| Fax/Telex: | 213-923-0022 | [2]: | | Added: | 06/14/87 | | |
| Bank Accounts | | | | | | | |
| Bank | Acct Type | EDI | Branch | Bank Account | Begin Date | End Date | |
| bank | 10 | | | | / / | / / | |

Fig. 6.12

Bank Accounts Frame in Supplier Maintenance (2.3.1)

Bank. Enter a code identifying the payment bank.

Account Type. Enter a type code to distinguishes multiple bank accounts for the same bank. You can define up to 10 account types. The following three types already exist in the system:

Tip

Designate at least one bank account as type 1 (ALL) so that the AP check selection and printing programs can always find a bank account for payments.

- 1 (ALL). The default. Indicates that the supplier bank account accepts both wire transfers and printed checks.
- 2 (PRT). Indicates an account that accepts only printed checks. Type 2 accounts are not used for electronic funds transfers (EFTs). Record these accounts for reference only.
- 3 (EDI). Indicates an electronic data interchange account.

EDI. Optional EDI number, not currently used by the system. Available for reference.

Branch. Optional and not currently used by the system. Available for reference.

Bank Account. The bank account code can have up to 23 characters. Set the System/Account Control File (36.1) to validate 11- and 12-digit customer and supplier bank account codes.

Begin/End Dates. Enter the time period in which this bank is valid for supplier payments. When you run Payment–Automatic Checks (28.9.9), the system selects this bank as the supplier’s destination bank for the payment only if the check date falls within the begin/end date range. The beginning date defaults to the system date. The end date remains open unless you specify one. These dates can be modified at any time.

Setting Up Credit Terms and Trailer Codes

Set up credit terms codes in Credit Terms Maintenance (2.19.1). The system uses credit terms codes to calculate the default due date, discount date, and discount for any goods and services bought or sold. Each of these fields can be overridden manually. Credit terms codes are also used for processing customer payments, debit/credit memos, vouchers, and checks. Due dates and discount dates can be fixed, or calculated from the invoice date, end of month, end of fortnight, or end of week.

For terms requiring multiple due dates or discount dates, set up two-tiered, compound credit terms.

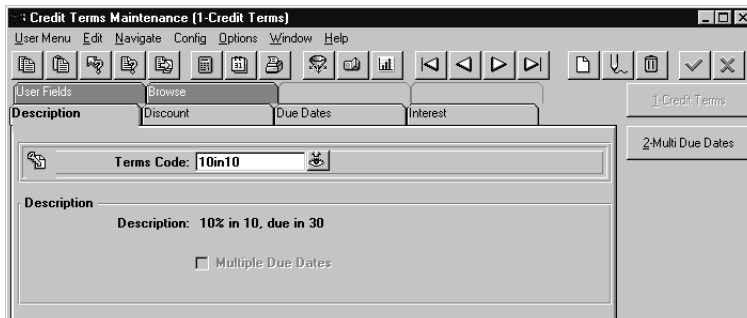

Fig. 6.13
Credit Terms
Maintenance
(2.19.1)

Proximo Terms. Proximo terms are a type of credit term used in France and some other countries. They enable you to manage due dates so that you process most payments only once a week, once a fortnight, or monthly, ensuring that customers have adequate time to pay. Specify the minimum number of days that must elapse between the invoice date and the payment due date.

Base Date. Specify a base date as the start date for due date calculations. Do this in situations where goods are shipped in advance of a negotiated invoice date but payment is made relative to the invoice date.

Credit Terms Interest. Specify a credit terms interest percentage for recalculating line item prices. You can also give favored customers a grace period on the payment due date by specifying the base days. Both the Disc Date From and Due Date From fields support end of fortnight (option 3) and end of week (option 4), as well as invoice date (option 1) and end of month (option 2).

Proximo Terms

Define proximo terms if your company processes payments only on certain days of the month. All payments may be due the same day (for example, the 10th of next month), regardless of invoice date. You specify this by setting Due Date From to 2, indicating the end of month.

In another example, invoices for the first half of the month are due on the 15th of the following month. Invoices for the second half of the month are due on the last day of the following month. For these terms, set Due Date From to 3 (end of fortnight).

Similarly, invoices for the first week are due at the end of the first week of the following month, invoices for the second week are due at the end of the second week of the following month, and so on. For these terms, set Due Date From to 4 (end of week).

However, if you specify only the Due Date From, the amount of time between the invoice date and the payment due date may be too short for a reasonable response. For example, for the end of month proximo terms described above, an invoice dated September 30 would be due October 10. To prevent this situation, specify the Min Due Days. This feature moves the due date to the next period whenever the number of days between the invoice date and the payment due date is too short for a reasonable response.

There are many ways to set up proximo terms. Table 6.5 through Table 6.7 illustrate sample proximo terms defined with Credit Terms Maintenance.

Table 6.5

Proximo Terms:
One Month

Due Days = 10
Due Date From = 2
(End of Month)
Min Due Days = 15

You want to process payments on the 10th of the month, and there must be at least 15 days between the invoice date and the payment due date. For monthly proximo terms, Due Days identifies the calendar day of the payment month. Specify Due Days only for end-of-month proximo terms.

If Invoice Date Is:
June 1–30

Payment Due Date Is:
July 10

Table 6.6

Proximo Terms:
Bimonthly
(Fortnight)

Due Date From = 3
(End of Fortnight)
Min Due Days = 30

Your payment due date is either the 15th or the 30th of the following month, depending on the invoice date. Customers always have at least 15 days to pay.

For end of fortnight, the system uses 15th of the month during discount/due date calculations if transaction date is prior to 15th of the month. If transaction date is after 15th, the system uses end of current month in its calculations. Finally, if transaction date falls on 15th or last day of month, transaction date is used.

Invoice Dates:
June 1–14
June 15–30

Payment Due Dates:
July 15 and July 31

Due Date From = 4
(End of Week)
Min Due Days = 30

Your payment due dates are the Saturday of every week in the following month, depending on the invoice date. Customers always have at least 15 days to pay.

For end of week, the system uses the date of the subsequent Saturday during discount/due date calculations. If the transaction occurs on a Saturday, it uses the transaction date.

Invoice Dates:

June 1–3
June 4–10
June 11–17
June 25–July 1

Payment Due Dates:

July 8
July 15
July 22
July 29
August 5

Table 6.7
Proximo Terms:
Weekly

Base Date

Base Date lets you specify a start date for due and discount date calculations. This enables you to calculate dates that match customer expectations. For example:

- In inflationary environments where pricing is time-dependent.
- For special promotions.
- If your company has a tightly negotiated contract with a significant cash flow effect. In this case you may want to specify a credit terms code with a base date to ensure that the customer does not have to pay too soon.

When you specify a Base Date, the system uses the later of the invoice/ship date or the base date when calculating discount and due dates.

Credit Terms Interest

Credit terms interest percentages enable you to:

- Accrue estimated inflation increases included in sales and purchases.
- Track the interest component of an item price or cost separately from its list price component. Separate postings to accounts for credit terms interest applied and accrued are required under generally accepted accounting principles, since currency gain/loss is only an estimate.

Fig. 6.14
Credit Terms
Maintenance
(2.19.1)

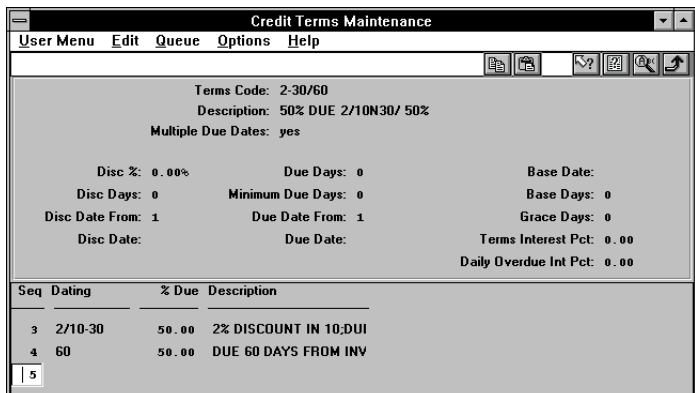

Base Days

In hyperinflationary environments, it is a common practice to offer a favored customer a due date that is later than the standard due date. These free days are not subject to credit terms interest. You can specify these days as Base Days in the credit terms code. When the system calculates due dates, it appends the Base Days to the calculated due date.

Note There is no connection between Base Date and Base Days, nor between Base Days and Due Days. In the latter case, Due Days specifies a time period that increments the Due Date From. Base Days specifies an interval that increments the calculated due date.

On sales and purchasing transactions, the credit terms interest percentage defaults from the transaction header credit terms code for the customer or supplier. You can change it if necessary. If you do, the system does not automatically update the credit terms interest percentage. A warning displays if the percentage in the header does not match the percentage for the credit terms code.

On sales transactions, a pop-up in the line item frame displays the credit terms interest percentage from the header, which you can override for the line item if necessary.

When you press Go, the system increments and displays the item's price based on the interest percentage. The line item discount, if any, is applied to calculate the item's net price.

On purchasing transactions, GL entries are created at PO receipt (5.13.1). Credit terms interest applied is debited and accrued interest is credited. These accounts are specified in the Purchasing Control File (5.24).

On sales transactions, GL entries are created at invoice post (7.13.4). Credit terms interest applied is credited and accrued interest is debited. These accounts are specified in the Sales Order Control File (7.1.24).

Note Currently, the system does not calculate adjusting entries on late payments.

Trailer Codes

In addition to line item charges and tax amounts, orders often have miscellaneous charges such as freight and service associated with them. Use Trailer Code Maintenance (2.19.13) to set up trailer codes prior to entering sales orders.

Trailer codes can be marked as taxable and associated with a GL account. Enter the GTM tax class of this trailer code. Trailer items are not subject to commission.

Once established, the three most frequently used taxable and nontaxable trailer codes can be specified as defaults in the Sales Order Control File (7.1.24). These defaults display on the trailer of every order but can be changed manually. Taxable and nontaxable trailer codes for contracts in Service/Support Management can be specified in the Contract Control File (11.5.24).

Setting Up Freight Charges

Many companies add freight charges to sales orders and RMAs. When the system calculates freight terms, it takes into account the shipper, ship-from site, ship-to address, shipment weight, currency, minimum weight, and other factors. Data affecting freight charges is derived from three sources:

- The order
- Customer information
- Freight information entered in the Freight Charges men

Table 6.8 lists the programs in the Freight Charges menu.

Table 6.8
Freight Charges
Menu (2.20)

| Number | Name | Program |
|---------|-----------------------------|------------|
| 2.20.1 | Freight List Maintenance | socn001.w |
| 2.20.2 | Freight List Browse | sobr002.p |
| 2.20.4 | Freight Zone Maintenance | sofrzmt.p |
| 2.20.5 | Freight Zone Browse | sobr006.p |
| 2.20.7 | Freight Class Maintenance | sofrclmt.p |
| 2.20.8 | Freight Class Browse | sobr001.p |
| 2.20.10 | Freight Charges Maintenance | sofrcmt.p |
| 2.20.11 | Freight Charges Browse | sobr005.p |
| 2.20.12 | Freight Charges Report | sofrcrp.p |
| 2.20.13 | Freight Terms Maintenance | sofrtmt.p |
| 2.20.14 | Freight Terms Browse | sobr003.p |
| 2.20.24 | Freight Control File | sofrctmt.p |

◆ See *User Guide Volume 2: Distribution* for details on how freight is calculated for a sales order.

Freight terms determine how shipping costs are displayed on the order. A customer's freight costs can appear on the order trailer or be added to each line item unit cost.

Once freight lists and terms are defined, assign default lists and terms to customers in Customer Maintenance. Each new sales quote or order created for the customer uses these values. Freight list, zone, and class are used to determine the freight charge for an order. The freight zone is based on the ship-to postal code. Freight class is determined by the item sold.

Freight List Maintenance

Use Freight List Maintenance (2.20.1) to define charges that apply to sales quotes and orders. Typically, you need at least one freight list for each shipping company you use. More than one freight list may be needed if the shipping company supports different types of transportation. For example, a shipping company may ship by train, by truck, by refrigerated truck, and by regular semi-trailer.

Set up freight lists for different currencies if your shipper delivers to other countries. You can also define lists per site if the same shipper transports from more than one warehouse or manufacturing site.

Fig. 6.15
Freight List
Maintenance
(2.20.1)

Type. Specify whether freight charges are based on the weight of each unit or on the total weight of the items that use this freight list. Valid entries are:

- **UNIT:** Freight charges are calculated for individual units based on each unit's shipping weight.
- **BULK:** Freight charges are calculated based on the total weight of applicable items. Weight is calculated for each order line as the unit weight multiplied by the line item quantity.

Trailer Code. This value links a freight list with the appropriate GL account to use when charging amounts on the sales quote, sales order, or pending invoice trailer.

Freight Mode. An optional code that can be used to describe the transportation method. Define values in Generalized Codes Maintenance for field *fr_mode*.

Freight Zone Maintenance

The distance an item is shipped can be an important factor in determining an order's freight charges. Use Freight Zone Maintenance (2.20.4) to set up geographical areas related to freight lists. Relate zones to sites by specifying values in the Site field.

Fig. 6.16
Freight Zone
Maintenance
(2.20.4)

Zones are bounded by a beginning and ending range of postal codes. Assign a starting and ending effective date, as needed.

Freight Zone Maintenance only sets up zones. Use Freight Charges Maintenance (2.20.10) to determine charges.

Freight Class Maintenance

Use Freight Class Maintenance (2.20.7) to set up classes used in calculating the freight charges defined in Freight Charges Maintenance. Freight class distinguishes different types of shipments requiring different charges. For example, a fragile class is charged at a higher rate because it requires extra handling.

Fig. 6.17
Freight Class
Maintenance
(2.20.7)

Associate freight classes with items in Item Master Maintenance (1.4.1).

Freight Charges Maintenance

Use Freight Charges Maintenance (2.20.10) to relate a freight list, class, and zone, and to specify how charges are calculated. Use start and end dates to phase in new charges if fees rise or fall after a certain date.

Fig. 6.18
Freight Charges
Maintenance
(2.20.10)

Maximum Weight. Enter the highest weight that can be used with a freight charge.

Freight Charge. Indicates a flat rate per shipment. The amount to be charged per order or per item as determined by the Type field in Freight List Maintenance.

Freight Charges Per UM Over Minimum. Indicates a surcharge over minimum. The freight charge per unit of measure over the minimum listed for this freight list in the Minimum Weight field. This is calculated per order or per item, based on the Type field in Freight List Maintenance.

Freight Charge Per Freight List UM. Indicates a weight-based fee. The freight charge for the unit of measure specified for the freight list in Freight List Maintenance.

Use any combination of these three types when defining freight charges. You can charge a flat rate plus a rate based on weight. Or you can charge a weight-based rate but with an additional charge for amounts over a certain minimum.

Freight Terms Maintenance

Freight Terms Maintenance is not directly related to the other freight maintenance functions. Terms are not related to a specific freight list or charge. Instead, they are specified for a particular customer in Customer Maintenance (2.1.1), or for a particular sales order, quote, or invoice.

Freight terms determine:

- Whether to apply freight charges to a particular order, or specify them in general for a particular customer.
- How freight charges are calculated. Table 6.9 lists the six methods for calculating freight charges.

Table 6.9
Freight Term Types

| Type | Description |
|-----------|---|
| Add | Freight is calculated and placed on the trailer. |
| Allow | Freight is calculated and shown as a negative amount on the trailer. |
| Collect | Accrued freight charges are calculated and placed on the trailer. |
| Include | Freight is calculated and added to the item's unit price (after you exit the order line item screen). |
| Prepaid | Freight is not calculated—it was prepaid or is a part of the selling price. |
| Will Call | Freight is not calculated—the customer is responsible for the shipping arrangements. |

By defining freight terms, you can assign your own codes and descriptions to these six types.

Changing or Merging Address Codes

To change or merge address codes, use Address Code Change (2.11).

Merging is allowed only if the old and new address codes both have a single, common list type. Customer and end user list types are considered the same for purposes of merging. For example, an address code for a customer can only be merged with an address code for another customer. An address code used for both a customer and a supplier cannot be merged.

Fig. 6.19
Address Code
Change (2.11)

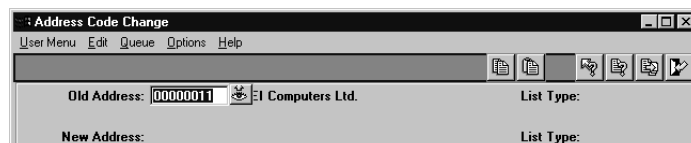

If you merge address codes, and both old and new address codes are already associated with a shipping group or shipment, the old address code is deleted rather than changed. This prevents duplication in the group.

▶ See *User Guide Volume 2: Distribution* for information on shipping groups.

Intrastat

European Union (EU) regulations require member nations to submit reports concerning Intra-EU trade. The term *Intrastat* (for *Intra-EU Trade Statistics Reporting*) refers to the system used by customs officials to monitor this trade. MFG/PRO eB fully supports Intrastat reporting requirements.

Introduction **198**

Implementing Intrastat **200**

Recording Intrastat Data for Orders **208**

Manually Creating Intrastat History **211**

Printing Intrastat Declarations **212**

Reprinting Intrastat Declarations **214**

Reviewing Intrastat History Information **214**

Deleting and Archiving Intrastat History **215**

Types of Intrastat Data **215**

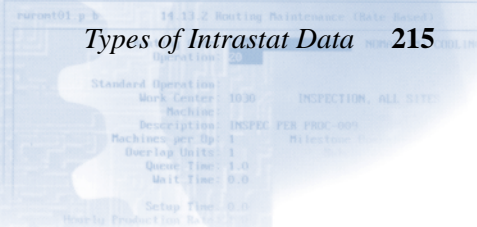

| Standard Operation | Work Center | Description | Machines per Op | Overlap Units | Queue Time | Wait Time | Setup Time |
|--------------------|-------------|----------------------|-----------------|---------------|------------|-----------|------------|
| | 1030 | INSPEC PER PROX-000 | 1 | 1 | 1.0 | 0.0 | 0.0 |
| | | INSPECTION, ALL SITE | | | | | |

Introduction

Intrastat offers powerful tools for companies doing business in EU member countries and for those wanting written documentation of inventory movements. You can:

- Generate Intrastat reports that are fully compliant with Intrastat legislation.
- Maintain tables with valid values for Intrastat codes such as terms of delivery and country codes.
- Assign Intrastat codes to items.
- Enter country codes for ship-to customers and suppliers.
- Record Intrastat codes for practically all MFG/PRO eB order types.
- Create automatic entries for qualifying Intra-EU inventory movement transactions.
- Edit Intrastat data manually before final declaration printing.
- Print and reprint Intrastat declaration reports.
- Create Intrastat inquiries by order, by invoice, or by voucher.

Table 7.1 lists the functions on the Intrastat menu.

Table 7.1
Intrastat Menu
(2.22)

| Number | Menu Label | Program |
|-----------|-----------------------------------|------------|
| 2.22.1 | Intrastat Setup Menu ... | |
| 2.22.1.1 | Flow Indicator Maintenance | ieflowmt.p |
| 2.22.1.2 | Flow Indicator Browse | iebr002.p |
| 2.22.1.4 | Terms of Delivery Maintenance | ietodmt.p |
| 2.22.1.5 | Terms of Delivery Browse | iebr008.p |
| 2.22.1.7 | Nature of Transaction Maintenance | ienotmt.p |
| 2.22.1.8 | Nature of Transaction Browse | iebr004.p |
| 2.22.1.10 | Country Code Maintenance | adctrymt.p |
| 2.22.1.11 | Country Code Browse | adbr015.p |
| 2.22.1.13 | Mode of Transport Maintenance | iemotmt.p |
| 2.22.1.14 | Mode of Transport Browse | iebr003.p |
| 2.22.1.16 | Port Maintenance | ieportmt.p |
| 2.22.1.17 | Port Browse | iebr005.p |
| 2.22.1.19 | Statistical Procedure Maintenance | iespmt.p |

| Number | Menu Label | Program |
|---------------|----------------------------------|----------------|
| 2.22.1.20 | Statistical Procedure Browse | iebr007.p |
| 2.22.1.22 | Region Maintenance | ieregmt.p |
| 2.22.1.23 | Region Browse | iebr006.p |
| 2.22.3 | Commodity Code Maintenance | iecommt.p |
| 2.22.4 | Commodity Code Browse | iebr001.p |
| 2.22.6 | Item Intrastat Data Maintenance | ieptmt.p |
| 2.22.7 | Item Intrastat Data Inquiry | ieptiq.p |
| 2.22.11 | Order Intrastat Data Maintenance | iedmt.p |
| 2.22.12 | Order Intrastat Data Report | ieordrp.p |
| 2.22.13 | Intrastat Maintenance | iehmt.p |
| 2.22.14 | Intrastat Inquiry | iehiq.p |
| 2.22.15 | Intrastat Inquiry by Invoice | iehinviq.p |
| 2.22.16 | Intrastat Inquiry by Voucher | iehvoui.p |
| 2.22.17 | Intrastat Inquiry by Order | iehordiq.p |
| 2.22.19 | Intrastat Declaration Print | iehpri.p |
| 2.22.20 | Intrastat Declaration Reprint | iehrpri.p |
| 2.22.23 | Intrastat Delete/Archive | iehup.p |
| 2.22.24 | Intrastat Control File | iepm.p |

Before Intrastat data can be collected and reports generated, you must set up and initialize several Intrastat codes and an Intrastat control file. These codes and settings are used during sales and purchase order processing. Figure 7.1 shows a general work flow for Intrastat.

Fig. 7.1
General Intrastat
Work Flow

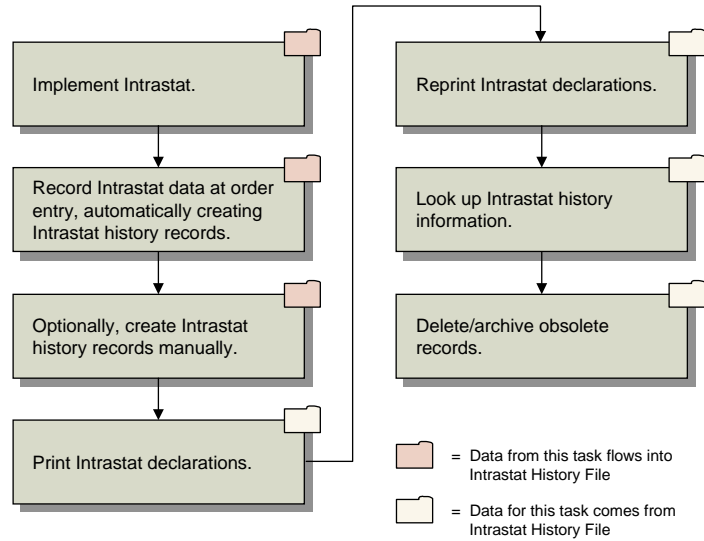

Implementing Intrastat

Figure 7.2 outlines typical steps for implementing Intrastat.

Fig. 7.2
Intrastat
Implementation
Work Flow

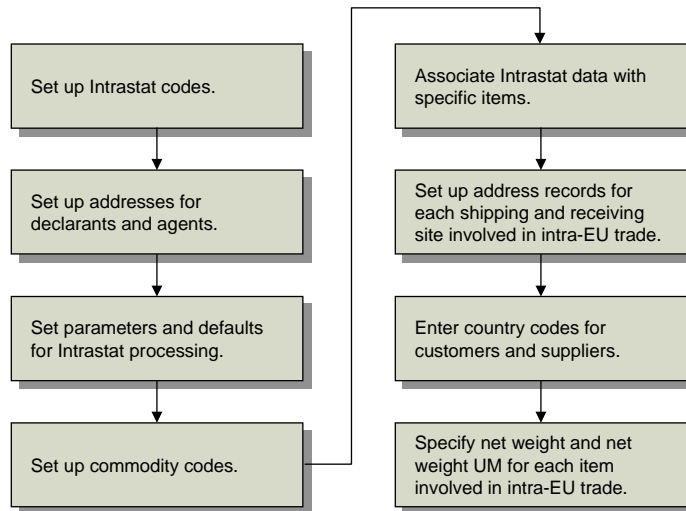

Setting Up Intrastat Codes

Figure 7.3 outlines typical steps for setting up Intrastat codes.

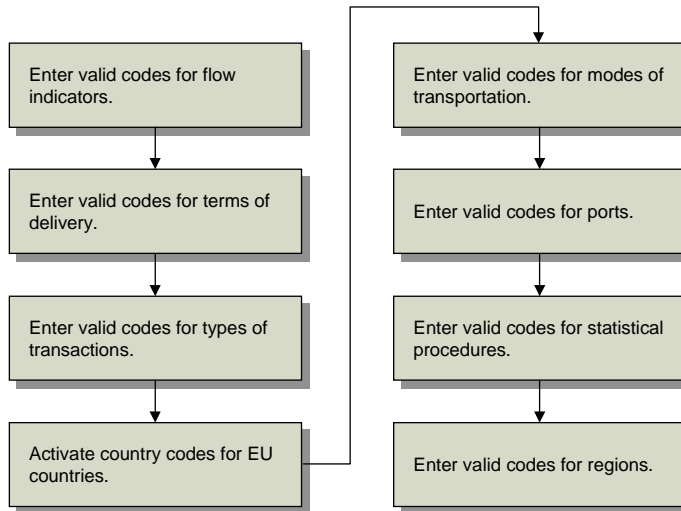

Fig. 7.3
Intrastat Code Setup

Depending on the requirements of the country where you use Intrastat, some codes are required and others are optional. For each maintenance program, there is a corresponding browse.

- Use Flow Indicator Maintenance (2.22.1.1) to define at least two flow indicators: one for Arrivals transactions and one for Dispatches transactions.
- Use Terms of Delivery Maintenance (2.22.1.4) to enter valid codes if your country requires this information.
- Use Nature of Transaction Maintenance (2.22.1.7) to enter valid codes if your country requires this information.
- Use Country Code Maintenance (2.22.1.10) to define countries where your company does business.

Enter Yes in the EU Country field to indicate that a country is a member of the EU. The system can then determine automatically when transactions involve Intra-EU inventory movements. The system uses this information to validate the Country of Destination/Dispatch and Country of Origin fields.

- Use Mode of Transport Maintenance (2.22.1.13) to enter valid codes if your country requires this information.
- Use Port Maintenance (2.22.1.16) to enter valid codes if your country requires this information. The system uses the information to validate the Port of Arrival/Dispatch and Port of Transshipment fields.
- Use Statistical Procedure Maintenance (2.22.1.19) to enter valid codes if your country requires this information for EDI transactions.
- Use Region Maintenance (2.22.1.22) to enter valid codes if your country requires this information.

Setting Up Addresses for Declarants and Agents

When printing Intrastat Declarations for declarants and agents, the system prints company address information in the declaration header. Use the Intrastat Control File (2.22.24) to establish defaults for declarant and agent addresses.

▶ See “Setting Up a Company Address for Each Site” on page 207.

It is common for companies to submit one consolidated Intrastat declaration monthly, requiring the setup of only one company address. If multiple monthly declarations are required, as when company sites are located in different countries, you must set up multiple company addresses.

Setting Up the Intrastat Control File

Use the Intrastat Control File (2.22.24) to set system-wide parameters for Intrastat processing and system-wide defaults for Intrastat data fields.

Fig. 7.4
Intrastat Control File (2.22.24)

The screenshot shows a window titled "Intrastat Control File" with a menu bar (User Menu, Edit, Queue, Options, Help) and a toolbar. The main area contains the following fields:

- Use Intrastat: no
- Imp/Exp Default: no
- Intrastat Net Weight UM:
- Intrastat Net Weight Minimum:
- Flow Indicator - Arrivals:
- Flow Indicator - Dispatches:
- Reference Date Logic:
- Include Memo Items: no
- Declarant:
- Agent:
- Branch ID:
- Branch ID:
- Commodity Code:
- Mode of Transport:
- Terms of Delivery:
- Nature of Transaction:
- Statistical Procedure:
- Port of Arr/Disp:
- Port of Transshipment:

Use Intrastat. Enter No if you do not want the system to automatically create Intrastat history records. If No, you can still create records manually.

▶ See “Manually Creating Intrastat History” on page 211.

Enter Yes to have the system automatically create Intrastat history records for applicable invoice and receiver lines.

- Invoice Post (7.13.4) automatically creates an Intrastat history record for each sales invoice line that relates to both an Intrastat item and a shipment to or receipt from another EU country.
- All programs that create purchase receivers (prh_hist records) automatically create an Intrastat history record for each receiver line that relates to both an Intrastat item and a shipment to or receipt from another EU country.

The system determines whether a sales invoice or receiver line is involved in Intra-EU inventory movement by comparing the country codes associated with the ship-from or receipt site and the Country of Destination/Dispatch for the related order line. If the codes are not the same and both relate to EU countries, the transaction is an Intra-EU transaction. If source and destination countries are the same, the transaction is considered domestic.

An invoice or receiver line is considered an Intrastat item when Intrastat Item is Yes in the corresponding order line.

Imp/Exp Default. This field determines the default for Imp/Exp on many order maintenance programs. Imp/Exp controls whether the Intrastat Data frame appears during order maintenance. Enter Yes if most of your sales orders and other order types are subject to Intra-EU reporting. Otherwise, enter No.

Intrastat Net Weight Unit of Measure. Enter the unit of measure code you use to indicate kilograms, the unit of measure in which the net weight of Intrastat transactions must be reported. If the net weight in the item master is not expressed in this unit, the system converts it.

Intrastat Net Weight Minimum. Enter the minimum legal net weight to be reported for an Intrastat transaction. The system rounds up the extended net weight for the transaction to this value.

Tip

Define these codes first in Flow Indicator Maintenance (2.22.1.1).

Flow Indicator Arrivals/Flow Indicator Dispatches. Enter the codes used in your country to indicate Intrastat arrival and dispatch transactions.

Reference Date Logic. Enter 1, 2, or 3 to indicate the method you use to assign a reference date to purchasing-related Intrastat history records.

1. Inventory transaction effective date
2. Voucher effective date
3. Tax point or voucher date. The system records whichever date falls earlier in the month. The tax point date is the 15th day of the month following the transaction effective date.

For sales-related Intrastat transactions, the reference date is always set to the invoice effective date.

The reference date assigned to an Intrastat history record determines when it is reported. Reference date is the main criterion for selecting Intrastat history records for reporting.

Include Memo Items. Enter Yes if you typically create Intrastat history records for memo items. Otherwise, enter No. This value becomes the default for Include Memo Items on order headers. You can override it during order entry.

Declarant Branch ID and Agent Branch ID. Optional. Enter the company address codes to use as the default declarant and default agent in Intrastat Declaration Print (2.22.19).

Commodity Code. Enter the commodity code to use when an Item Intrastat Data record does not exist.

Mode of Transport and Port of Transshipment. Enter the default transportation code values for Intrastat orders. You can change these values during order entry. These are optional fields.

Automatically Updating Intrastat History Records at Vouchering

Voucher Maintenance (28.1) automatically updates the Intrastat history record associated with each voucher receiver line when the line closes.

The following Intrastat data is recorded for each voucher receiver line:

- Reference date (if reference logic is 2 or 3)
- Statistical value in base currency
- Invoice value in transaction currency
- Voucher number
- Invoice value in base currency
- Voucher date

▶ See “Reference Date Logic” on page 204.

Setting Up Commodity Codes

Use Commodity Code Maintenance (2.22.3) to set up codes for classifying goods for Intrastat reporting. Create codes for each EU country, since each has its own coding scheme for the last four digits.

Note Intrastat commodity codes are distinct from the corporate commodity codes defined in Commodity Code Maintenance.

▶ See page 19 for details.



Fig. 7.5
Commodity Code Maintenance (2.22.3)

Country. Enter a valid country code for each country in which your company has sites.

Commodity Code. Enter a commodity code.

Description. Enter a description of the commodity.

Supplementary UM. Enter an optional supplementary unit of measure. For conversions, this value must be defined in Unit of Measure Maintenance (1.13).

Some commodity codes require that an item be tracked in a specified unit of measure. If the line UM differs from the supplementary UM when Intrastat history records are created, the line quantity is converted to the supplementary UM.

Setting Up Intrastat Item Data

Use Item Intrastat Data Maintenance (2.22.6) to associate Intrastat data with inventory items involved in Intra-EU transactions. The values entered here appear in orders as defaults, and can be changed at order entry. Create a record for each EU country.

Fig. 7.6
Item Intrastat Data
Maintenance
(2.22.6)

Authority. For Intrastat purposes, always set this to INSTAT.

Country. Enter a country code.

Item Number. Enter an item number.

Commodity. Enter a commodity code. To associate a commodity code with a country, you must also associate it with that country in Commodity Code Maintenance (2.22.3).

Country of Origin. Enter a country of origin code.

Intrastat Item. Enter Yes to have the system automatically create Intrastat history records for the item. For items for which you do not want Intrastat records created, such as intangible goods or items related to motorized vehicles, enter No.

Setting Up a Company Address for Each Site

Use Company Address Maintenance (2.12) to set up address records for each shipping and receiving site used in Intra-EU inventory movements. This program also lets you associate each site with a country and region code.

Specify the site code entered in Site Maintenance (1.1.13).

Country Code

Company Address Maintenance

User Menu Edit Queue Options Help

Company Address

Address: 100002

Name: Quality Products Inc

Address: Service Division

Address: 1200 Hamburg Place

City: Hamburg State: Post: 33821 Format: 1

Country: GER County:

Attention: Hans Schmidt [2:]

Telephone: 887-2000 Ext: [2:]

Fax/Telex: [2:]

Fig. 7.7
Company Address Maintenance (2.12)

Address. Enter an address code. If the code you entered is for a new record, enter the address in the address fields.

State. Enter a region code in the State field if one is required on Intrastat declarations.

Entering Country Codes for Customers and Suppliers

Country codes entered in the following programs become defaults for Country of Destination/Dispatch on customer and supplier orders. You can change these codes at order entry. This is useful when the shipping/receiving site of the supplier/customer is in a different country from where the order is sent (*triangulation*).

- Use Supplier Maintenance (2.3.1) to enter country codes for suppliers.
- Use Customer Maintenance (2.1.1) to enter country codes for customers.
- Use Ship-To Maintenance (2.1.13) to enter ship-to addresses for customers.

Entering Net Weights for Intrastat Items

Use Item Master Maintenance (1.4.1) or Item Inventory Data Maintenance (1.4.5) to specify net weight and net weight unit of measure (UM) for each item involved in Intra-EU inventory movements.

Note The Corporate Commodity Code field in Item Master Maintenance does not reference Intrastat commodity codes.

Fig. 7.8
Item Master Maintenance (1.4.1), Item Shipping Data

| Item Data | |
|------------------|-----------------------|
| Prod Line: 1000 | Item Type: fmgood |
| Added: 04/03/00 | Status: AC |
| Design Group: | Group: |
| Promotion Group: | Price Break Category: |

| Item Shipping Data | |
|--------------------|----|
| Corp Comm Code: | |
| Ship Weight: 10.10 | KG |
| Freight Class: | |
| Net Weight: 10.00 | KG |
| Volume: 200.00 | CC |

The UM field is to the right of the Net Weight field. The system calculates net weight when creating Intrastat history records.

Net Weight. Enter item net weight.

Unit of Measure. Enter item unit of measure.

Recording Intrastat Data for Orders

Once Intrastat is set up, you can record Intrastat data using either standard order maintenance programs or Order Intrastat Data Maintenance (2.22.11).

Entering Intrastat Data in Sales Order Maintenance

This section describes how to enter Intrastat data in Sales Order Maintenance (7.1.1). The same steps can be used to record Intrastat data in most other standard order maintenance programs.

1 Use Sales Order Maintenance (7.1.1) to enter an order as usual.



Fig. 7.9 Sales Order Maintenance (7.1.1)

Imp/Exp. Enter Yes to record Intrastat data for this order. When the Intrastat frame displays, enter Intrastat data.

If No, special processing does not occur during order maintenance. You can still add Intrastat data later using Intrastat Maintenance (2.22.13).

Record Intrastat data in the Intrastat frame of the order header. Fields default from the Intrastat Control File. Defaults to the country code associated with the ship-to customer.

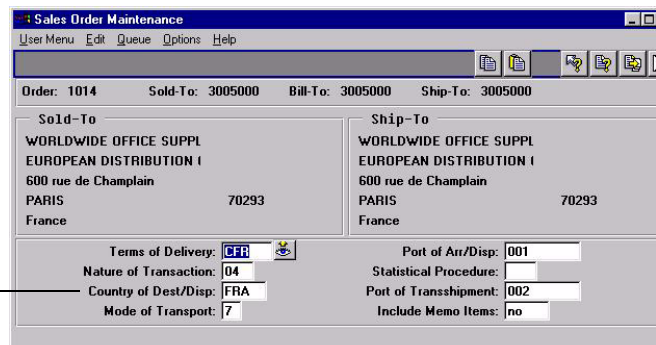

Fig. 7.10 Sales Order Maintenance, Intrastat Frame (7.1.1)

2 Choose Go to enter order lines.

The system automatically copies the Intrastat header data to each order line. When all order lines and the order trailer are entered, you are prompted to view or edit import/export data. Choose Yes to display the following window.

Fig. 7.11
Viewing Intrastat
Data in Sales Order
Maintenance
(7.1.1)

Scroll through
the order lines
by positioning
the cursor in the
Order Line field
and pressing
the Up or Down
arrow keys.

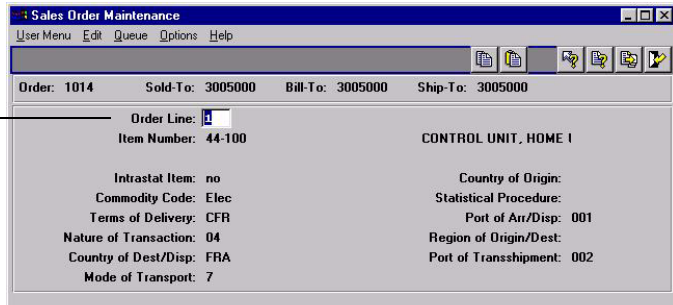

In most cases, Intrastat codes entered in the order header apply to all order lines. Where there are exceptions to this, Intrastat information can be entered and maintained at the line level.

Entering Data in Order Intrastat Data Maintenance

Use Order Intrastat Data Maintenance (2.22.11) to enter all Intrastat data in one frame and to review and modify Intrastat data at any time between order entry and shipment. However, you can only *delete* order data using the appropriate order maintenance program. At invoice posting, this information is recorded in the Intrastat history file.

Fig. 7.12
Order Intrastat Data
Maintenance
(2.22.11)

Use Order
Intrastat Data
Maintenance to
enter all
Intrastat data in
one frame.

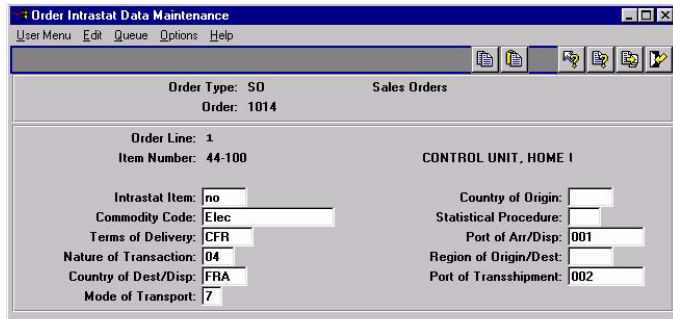

Manually Creating Intrastat History

Use Intrastat Maintenance (2.22.13) to add and modify Intrastat records directly in the Intrastat history file. This is useful for data that are not entered automatically, such as:

- DRP transactions
- Transfers that use transactions on the Inventory Transfer Menu (3.4)
- Installed base item movements in Installed Item Move (11.3.13)
- Goods sent out for processing in the Advanced Repetitive module using the programs on the Subcontract Shipping Menu (18.22.5)

Note You cannot modify Intrastat history records that have been declared on a final print.

▶ See “Printing Intrastat Declarations” on page 212.

Fig. 7.13
Intrastat
Maintenance
(2.22.13)

Reference. Specify which document contains the Intrastat data. This field is normally updated by the system and displays the order type, order number, and order line or reference (invoice number or receiver number).

Invoice Value. Enter the invoice value in transaction currency.

Invoice Cur. Enter the currency designation for this invoice.

Statistical Value. Enter the statistical value of the order. This field defaults from the invoice value in base currency.

Supplementary Units. The system calculates and displays the number of supplementary units, based on the supplementary UM associated

with the item’s commodity code, if any. If the line quantity UM is different from the commodity code’s supplementary UM, the system automatically applies the conversion factor defined in Unit of Measure Maintenance.

If a supplementary UM is not available, supplementary units are not calculated.

Net Weight. Enter the weight of the transaction in kilograms. The unit of measure for kilograms is specified in the Intrastat Control File. If net weight is not specified, it is calculated based on the net weight and UM associated with the item in Item Master Maintenance.

Printing Intrastat Declarations

Use Intrastat Declaration Print (2.22.19) to print Intrastat declarations that are fully compliant with Intrastat regulations. You can print declarations for arrivals, dispatches, or both, in any of four forms: trial, final, summary, or detail. The Intrastat declaration report layout is generic, allowing it to be customized locally using standard PROGRESS tools.

Fig. 7.14
Intrastat
Declaration Print
(2.22.19)

Tip
Intrastat
Declaration Print
only selects
Intrastat history
records that have
not been reported
on a final
declaration.

Reference Date and Site. Enter a range of reference dates or sites for Intrastat history records to be included in the declaration.

Print Intrastat Declaration Arrivals and Dispatches. Enter Yes in both fields to print both kinds of declarations.

Trial/Final. Enter Trial to print a draft of the declaration. Enter Final to print the declaration in final form. The system prompts you to

confirm that the declaration printed correctly. Choose No to reprint the document. Choose Yes to update selected Intrastat history records so they are not included on another declaration. Records are updated as follows.

- Reference to the declaration on which the record was reported (Period, Submit Date, and Declarant field).
- Reported invoice value and statistical value.
- Reported flag is set to Yes.
- Intrastat Declaration ID is added to each declared record.

Summary/Detail. Enter Summary to print a summary report organized by the following:

- Commodity Code
- Terms of Delivery
- Nature of Transaction
- Country of Dest/Disp
- Mode of Transport
- Country of Origin
- Port of Arr/Disp
- Region of Origin/Dest
- Port of Transshipment
- Statistical Procedure

Enter Detail to print each record as an individual line item.

Year, Period, Declarant, Agent. Specify for which year, period (month of year), submit date, declarant, and agent you are printing the Intrastat declaration.

Submit Date. Defaults to the system date. This date prints on the declaration.

Reprinting Intrastat Declarations

Use Intrastat Declaration Reprint (2.22.20) to reprint declarations submitted in the past. You have the option of reprinting in summary or detail, regardless of how the original was printed.

Fig. 7.15
Intrastat
Declaration Reprint
(2.22.20)

Declaration ID. Enter the ID of the declaration to be reprinted. This is a unique identifier automatically assigned to all Intrastat history records included in a final Intrastat declaration. This ID is printed on the Intrastat declaration. Use the Up and Down arrows to scroll through history records to find the declaration you want to reprint.

Reviewing Intrastat History Information

Four inquiries are available for reviewing Intrastat history information. All show the same information, but differ by search criteria and sort methods.

- Use Intrastat Inquiry (2.22.14) to review Intrastat history records by transaction ID (the sequence in which the system creates them).
- Use Intrastat Inquiry by Invoice (2.22.15) to review Intrastat history records by invoice number.
- Use Intrastat Inquiry by Voucher (2.22.16) to review Intrastat history records by voucher number.
- Use Intrastat Inquiry by Order (2.22.17) to review Intrastat history records by order number.

Deleting and Archiving Intrastat History

Use Intrastat Delete/Archive (2.22.23) to delete or archive Intrastat history records. Use Archive File Reload (36.16.5) to return history records to the database.

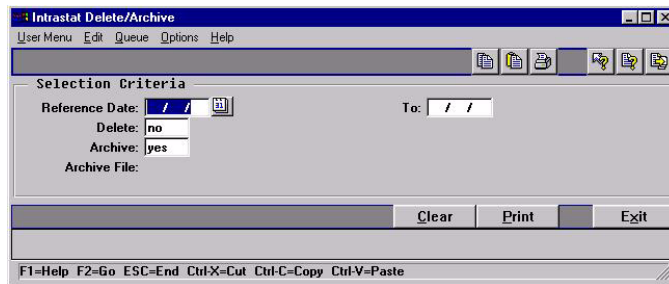

Fig. 7.16
Intrastat Delete/
Archive (2.22.23)

Delete. Enter yes to delete information or No to review selected records.

Archive. Enter Yes to copy each selected record to the disk file displayed in the Archive File field.

Types of Intrastat Data

Recorded data for each Intrastat history record can be classified into three groups:

- *Qualitative information* describes inventory movement and helps customs officials understand trends in the flow of goods.
- *Quantitative information* describes the value, net weight, and supplementary UM (if required) of the inventory movement. This information gives customs officials the currency value of the shipment both in net and unit measurements.
- *Audit trail information* gives you a way to match Intrastat data to the business transactions from which it originated. This is useful for responding to customs inquiries and audits.

Table 7.2 lists the various data fields that belong to the three types of Intrastat data.

Table 7.2
Intrastat Data Types

| Qualitative Information | Quantitative Information | Audit Trail |
|-------------------------|---|---|
| Reference Date | Invoice Value in Transaction | Reference to the underlying sales invoice or receiver line; that is, Order Type, Order Number, Order Line, Receiver/Invoice |
| Country of Dest/Disp | Currency | |
| VAT Registration Number | Invoice Value in Base | |
| Flow Indicator | Currency | |
| Mode of Transport | Supplementary Units in the UM as required for the | |
| Region of Origin/Dest | Commodity Code | |
| Commodity Code | Statistical Value in Base | |
| Country of Origin | Currency | |
| Port of Transshipment | Net Weight in the Intrastat | |
| Terms of Delivery | Net Weight UM | |
| Statistical Procedure | | |
| Port of Arr/Disp | | |
| Nature of Transaction | | |

Note The statistical value is not automatically calculated because every EU country has its own definition of the statistical value calculation. Instead, a user exit program, `iestatvl.i`, is provided to calculate the statistical value. Customize this program to insert a new formula.

Inventory Control

MFG/PROeB's Inventory Control supports a broad range of activities including management of inventory transactions, lot/serial tracing, and inventory counting.

Introduction **218**

Setting Up the Inventory Control File **218**

Creating Inventory Detail Records **220**

Creating Inventory Transactions **220**

Creating Inventory Transaction History **223**

Creating Lot/Serial Number History **226**

Performing Cycle Counts **227**

Creating Inventory Reports **230**

Checking Inventory Availability **233**

Routing Code: 10-15000 MFG/PROeB CHG LINES

Operation: 20

Standard Operation

Work Center: 1030 INSPECTION, ALL SITE

Machine:

Description: INSPEC PER PROC-000

Machines per Op: 1 Allocation:

Overlap Units: 1

Queue Time: 1.0

Wait Time: 0.0

Setup Time: 0.0

Ready to Production

Introduction

Inventory Control supports a broad range of inventory activities. You can:

- Create inventory transactions such as unplanned issues and receipts or inventory transfers.
- Monitor inventory transactions and history records created elsewhere in the system, including lot/serial tracing.
- Generate reports and inquiries on the value and availability of inventory.
- Perform cycle counts to verify inventory quantities on hand.

Receipts to inventory and issues from inventory change a location's inventory balance and affect the General Ledger (GL). Inventory Control provides a complete audit trail of all inventory transactions, and enables you to track tools, documents, and non-inventory items (but not work-in-process items).

▶ See Chapter 9, "Physical Inventory," for details.

Use it to verify inventory by performing inventory counts and comparing actual quantities with system quantities. Two counting methods are supported: cycle counting and physical inventory counting.

Setting Up the Inventory Control File

The Inventory Control File (3.24) contains three types of settings:

▶ See "ABC Class Code" on page 228.

- **Inventory Count Parameters.** These determine how the system handles inventory balance variations during cycle counting and physical inventory. Tolerances can be set based on item ABC class.
- **Accounting Parameters.** These determine costing issues, whether GL transactions are created for inventory transactions, and other inventory accounting parameters.
- **Picking Logic.** Before the system can move inventory, it must know what inventory to select, or *pick*. The picking logic specified here determines how the system picks inventory.

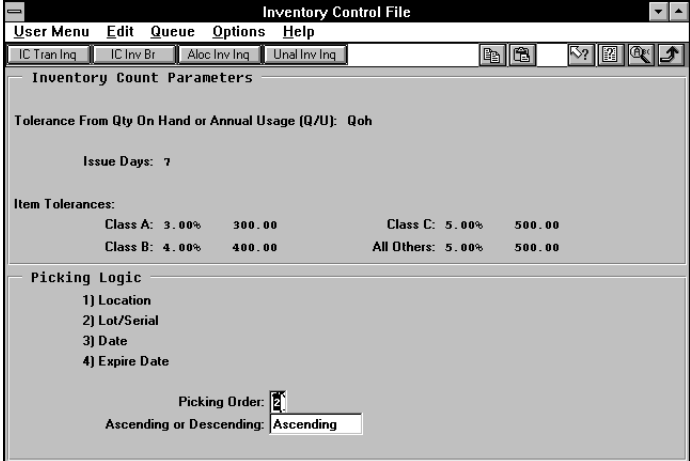

Fig. 8.1
Inventory Control
File (3.24)

Picking Order. Enter the method to use for selecting inventory during detail allocation.

1–Location. The system first looks for inventory by location, then by lot/serial number.

2–Lot/Serial. The system first looks for inventory by lot/serial number, then by location.

3–Date. The system first looks for inventory by the date the item was created or received, then by location and lot/serial number.

4–Expire Date. The system first looks for inventory by item expiration date, then by location and lot/serial number.

Ascending or Descending. Enter Ascending to have the system pick the oldest or lowest number first. Enter Descending to have the system pick the newest or highest number first. As an example, if Picking Order is by Date and Ascending order is specified, the first item picked is that with the oldest create or receipt date.

Creating Inventory Detail Records

Inventory detail records precisely define inventory balances and locations. Each record includes:

- Item number
- Site
- Location (if used)
- Lot/serial number (if used)
- Lot reference (if used)

The system calculates total item inventory by adding all on-hand balances from inventory detail records. Records also provide details on inventory status codes and expiration dates, grades, and assay percentages.

Modify inventory attributes using Inventory Detail Maintenance (3.1.1) or Detail Maintenance by Item/Lot (3.1.2). Use Inventory Detail by Lot Inquiry (3.1.13) to generate a report.

Creating Inventory Transactions

Inventory transactions move inventory to or from a location. Examples of inventory transactions include:

- Issuing existing inventory to a work order
- Receiving purchased materials into inventory
- Shipping goods

Fig. 8.2
Inventory
Transaction Flow

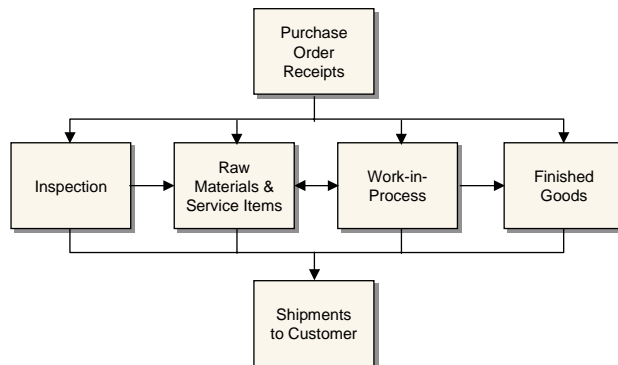

Use the programs in Table 8.1 to create inventory transactions.

| Menu Number | Program |
|-------------|---|
| 3.4.1 | Transfer–Single Item |
| 3.4.2 | Transfer–Multi Item |
| 3.4.3 | Transfer With Lot/Serial Change |
| 3.4.4 | Batchload Transfer With Lot/Serial Change |
| 3.7 | Issues–Unplanned |
| 3.8 | Issues–Return to Supplier |
| 3.9 | Receipts–Unplanned |
| 3.10 | Receipts–Sales Order Return |
| 3.11 | Receipts–Return to Stock |
| 3.12 | Receipts–Backward Exploded |

Table 8.1
Inventory Transfer
Menu (3.4)

Transfers

A transfer is a movement of inventory to a new location. You can use three kinds of inventory transfers: single item, multi-item, and transfer with lot/serial change.

- Use Transfer–Single Item (3.4.1) to transfer a specified quantity of a single item from one location to another. If inventory status codes specified in the From and To fields differ for an item, you can select the one to be used.
- Use Transfer–Multi Item (3.4.2) to transfer more than one item from one location to another. Only entire quantities are transferred—not partial quantities. This transaction generates a report showing the items and quantities transferred.
- Use Transfer With Lot/Serial Change (3.4.3) to transfer a specified quantity of a single item from one location to another *and* change the lot/serial and lot reference numbers associated with the item.
- Use Batchload Transfer With Lot/Serial Change (3.4.4) for the same purpose as 3.4.3. However, this program also supports CIM loading of inventory information by allowing you to specify values for fields that are prompted for interactively in the standard Transfer With Lot/Serial Change.

♦ See *User Guide Volume 9: Manager Functions* for details on CIM.

▶ See *External Interface Guide: Warehousing*.

This is especially important, for example, with the Warehousing Interface, which relies on CIM load to transfer data between the MFG/PRO eB database and an external warehouse.

If Verify GL Accounts is Yes in the System/Account Control File, the system checks the GL calendar to ensure that the effective date specified for a transfer is within an open fiscal period. The default effective date is the system date. If a shipping group exists for a transfer, you can create a shipper for the transferred items.

Receipts

A receipt is when inventory is brought into a location. Receipts increase the quantity on hand of an item at a particular location. Use the following programs to receive inventory that does not have an existing or open order:

- Use Receipts–Unplanned (3.9) to receive miscellaneous inventory such as floor stock items sent back from production, or materials from a manufacturing order that has been closed from an accounting standpoint.
- Use Receipts–Sales Order Return (3.10) to tag a receipt as a return only if you do not use Sales Orders/Invoices. This is not a complete return since it does not update sales or commission history, and does not generate a credit invoice.
- Use Receipts–Return to Stock (3.11) to return to stock miscellaneous items that have been temporarily moved elsewhere.
- Use Receipts–Backward Exploded (3.12) to increase inventory quantity for an item at a designated site and location and decrease inventory for its components. Backward-exploded receipts are often used in kitting or simple assembly operations, where there is no need for a work order. Recording receipt of a finished item indicates that an associated set of items was used.

Issues

An issue sends inventory to a different location. For example, when components are issued to a work order, they are removed from the stocking location and issued to the work-in-process (WIP) location. Inventory issues reduce quantities on hand at the issuing location.

- Use Issues–Unplanned (3.7) to record miscellaneous inventory issues such as floor stock items sent to production or materials sent to engineers for testing. You can also issue items to a manufacturing order that closed from an accounting standpoint.
- Use Issues–Return to Supplier (3.8) to tag an issue as a return. This is not a complete return since it does not update purchasing or receiving history, or current cost. To process a complete return, use functions in the Purchasing module.

Shipping Documents

Many countries require that formal shipping documents accompany any movement of goods, even when goods are merely transferred, not sold. If you are using shipping groups, you can record shipping information and generate shipping documents from all the inventory transfer programs.

▶ See the Shipping chapter in *User Guide Volume 2: Distribution* for details.

Creating Inventory Transaction History

Every inventory transaction creates a record in the inventory transaction history file. Each record has a unique, sequential transaction number, a transaction type, and includes the following information:

- Transaction data
- Inventory data
- Cost data
- GL transaction data
- User ID of the person entering the transaction

Transaction Types

The transaction type code identifies the function used to initiate the inventory change. Table 8.2 lists the transaction type codes included in inventory history records with a brief description of each type and the name of one of the programs that creates the transaction.

Note Many of these transactions are created in more than one program. In this case, the table simply indicates a typical program associated with the transaction and is not intended to be a complete list.

▶ See “Inventory Status Codes” on page 32.

Each inventory status code can include a list of restricted transactions. This allows you to manage how items, locations, and sites are used. However, to maintain system integrity, some transactions cannot be restricted this way.

Note In Table 8.2, transactions that cannot be restricted appear in boldface type.

Table 8.2
Inventory
Transaction Types

| Transaction Type | Description | Program Creating |
|------------------|-----------------------------|--|
| CST-ADJ | Standard cost adjustment | Item Master Maintenance (1.4.1) |
| CUM-RADJ | Cumulative received adjust | Cumulative Received Maintenance (5.5.5.13) |
| CUM-RRES | Cumulative received reset | Cumulative Received Reset to Zero (5.5.5.14) |
| CUM-SADJ | Cumulative shipped adjust | Cumulative Shipped Maintenance (7.5.16) |
| CUM-SRES | Cumulative shipped reset | Cumulative Shipped Reset (7.5.18) |
| CYC-CNT | Cycle count adjustment | Cycle Count Results Entry (3.14) |
| CYC-ERR | Cycle count error | Cycle Count Results Entry (3.14) |
| CYC-RCNT | Cycle count recount | Cycle Count Results Entry (3.14) |
| ISS-CHL | Location change issue | Inventory Detail Maintenance (3.1.1) |
| ISS-DO | Distribution order shipment | Distribution Order Shipments (12.17.22) |
| ISS-FAS | Final assembly order issue | Sales Order Shipments (7.9.15) |
| ISS-GIT | Distribution order receipts | Distributed Order Receipts (12.15.20) |
| ISS-PRV | Return to vendor (supplier) | Purchase Order Return (5.13.7) |
| ISS-RV | return to vendor (supplier) | Issues–Return to Supplier (3.8) |
| ISS-SO | Issue sales order item | Sales Order Shipments (7.9.15) |

| Transaction Type | Description | Program Creating |
|-------------------------|------------------------------|---|
| ISS-TR | Inventory transfer issue | Transfer–Single Item (3.4.1) |
| ISS-UNP | Inventory unplanned issue | Issues–Unplanned (3.7) |
| ISS-WO | Issue work order item | Work Order Component Issue (16.10) |
| ORD-PO | Purchase order booking | Purchase Order Maintenance (5.7) |
| ORD-SO | Sales order booking | Sales Order Maintenance (7.1.1) |
| ORD-SEO | Material order booking | Material Order Maintenance (11.11.1) |
| RCT-CHL | Location change receipt | Inventory Detail Maintenance (3.1.1) |
| RCT-DO | Distribution order receipt | Distributed Order Receipt (12.15.20) |
| RCT-FAS | Receive final assembly | Sales Order Shipment (7.9.15) |
| RCT-GIT | Distribution order shipment | Distribution Order Shipments (12.17.22) |
| RCT-PO | Purchase order receipt | Purchase Order Receipts (5.13.1) |
| RCT-RS | Inventory return to stock | Receipts–Return to Stock (3.11) |
| RCT-SOR | Inventory sales order return | Receipts–Sales Order Return (3.10) |
| RCT-TR | Inventory transfer receipt | Transfer–Single Item (3.4.1) |
| RCT-UNP | Inventory unplanned receipt | Receipts–Unplanned (3.9) |
| RCT-WO | Receive work order item | Work Order Receipt (16.11) |
| RJCT-WO | Reject work order item | Work Order Receipt (16.11) |
| TAG-CNT | Physical inventory update | Inventory Balance Update (3.16.21) |
| WIP-ADJ | Work-in-process adjustment | WIP Material Cost Revaluation (16.22) |
| WO-CLOSE | Work order close | Work Order Accounting Close (16.21) |

Reviewing Transaction History

Use the programs on the Transaction History Menu (3.21) to view inventory transaction history.

- Use Transactions Detail Inquiry (3.21.1) to display detailed inventory transaction history records ordered by transaction number.
- Use Transactions by Item Browse (3.21.2) to display inventory transaction history for an item number ordered by transaction date, starting with the most recent.
- Use Transactions by Order Report (3.21.13) to display inventory transaction history by sales order or work order number.

- Use Transactions by Item Report (3.21.14) to display inventory transaction history by item number.
- Use Transactions Accounting Report (3.21.16) to display the costed GL transactions created for each transaction.
- Use Average Cost Accounting Report (3.21.17) to list selected transactions involving average cost computations. The report shows quantity, unit cost, and inventory value for the beginning balance, the change data, and the ending balance.
- Use Transactions Delete/Archive (3.21.23) to remove transactions from the system when online history is no longer needed.

Creating Lot/Serial Number History

Lot/serial control is an inventory attribute assigned in Item Master Maintenance. When you mark an item as lot/serial controlled, you cannot issue or receive the item without specifying a number.

As transactions are processed for an item, its lot/serial number is included in transaction history. Lot/serial numbers provide greater tracking control by creating records of an item's movement through the manufacturing process.

▶ For details, see the *PRO/PLUS User Guide*.

Note The PRO/PLUS WIP Lot Trace module (WLT) affects lot/serial collection and reporting features, while adding detailed component, work in process (WIP), and finished goods lot/serial tracing and reporting options. If you are using the optional PRO/PLUS module, WIP Lot Trace is available as menu option 3.22.13.

To review lot/serial history information, use the programs on the Lot/Serial Number Menu (3.22).

- Use Lot Transactions by Date Browse (3.22.1) to review an item's inventory transactions by date.
- Use Lot Transactions by Tran Browse (3.22.2) to review an item's inventory transactions by transaction number.
- Use Lot Actual Bill Inquiry (3.22.3) to display components used to make a lot/serial controlled item.

Show Duplicates. Enter Yes to allow transactions to appear more than once in an inquiry display. For example, a purchase receipt (RCT-PO)

can appear once in relation to a work order issue (ISS-WO) and again in relation to an inventory status change (ISS-CHL). Enter No to have transactions appear only in the first sequence found.

Max Workfiles. Enter a number telling the system how many workfiles to create during execution. The default is 500. Entering a value greater than your system's processing capacity can cause the system to fail. To reduce the number of workfile records, narrow the range of items selected.

- Use Lot Where-Used Inquiry (3.22.4) to display all top-level items containing a lot/serial numbered component.

Show Duplicates. Enter Yes to allow transactions to appear more than once in an inquiry display. Enter No to have transactions appear only in the first sequence found.

Performing Cycle Counts

You can count and compare actual, on-hand inventory balances with system-maintained quantities using either of two counting methods:

- Cycle counting (Inventory Control)
- Physical counting (Physical Inventory)

In each method, you count inventory by site, location, item, and lot/serial number. Cycle counting involves counting groups of items on a regular or cyclic schedule. A physical count involves counting all items, usually once a year.

During cycle counting, you enter manual count figures in the system. The system then compares the manual count figures with its figures. If there are discrepancies, the system checks the error tolerances defined in the Inventory Control File. If a count figure is within tolerance, it is accepted and the system's figure is updated. If a count figure is not within tolerance, the item in question must be recounted. The system accepts recount quantities that are out of tolerance.

▶ See Chapter 9, "Physical Inventory," for details.

ABC Class Code

The ABC class code classifies items by their importance in a manufacturing system and determines count frequencies. Class A items are counted more frequently than class B items. Class B items are counted more frequently than class C items.

Use Item Master Maintenance (1.4.1) or Item Inventory Data Maintenance (1.4.5) to assign ABC class. You can also have the system calculate it automatically by running Item ABC Status Report/Update (1.5.9 or 3.6.3).

For each ABC class, assign item tolerances (percentage and amount) in the Inventory Control File. When count discrepancies arise, the system checks item tolerances by class.

Cycle Counting Procedure

Whether you select items for cycle counting or have the system select them, the basic steps are as follows:

- 1 Print a cycle count worksheet.
- 2 Count the items listed on the worksheet.
- 3 Enter the initial count quantity in the system.
- 4 Review the results and enter recount quantities if necessary.

Printing Cycle Count Worksheet

Use Cycle Count Worksheet Print (3.13) to print a worksheet listing items selected for cycle counting, their locations, ABC code, last count date (if applicable), and the quantity on hand. Use the worksheet to record the count quantities.

The system selects items by comparing the current date with the item's last count date. If the elapsed time is greater than the period specified in the Cycle Count Interval field in Item Master Maintenance, the system selects the item for cycle counting. If this is the first time you are cycle counting an item, the system selects it by item number.

Entering Initial Count

Enter the count quantity in Cycle Count Results Entry (3.14). When entering the initial count quantity, set Cycle Count Type to I (Initial).

If an item's count quantity does not match the system's, the system checks to see if the count is within both the percent tolerance and the amount tolerance. If it is, the system updates its quantity accordingly. If the count is not within tolerance, the item must be recounted.

Tip
Tolerances are specified in the Inventory Control File by ABC class.

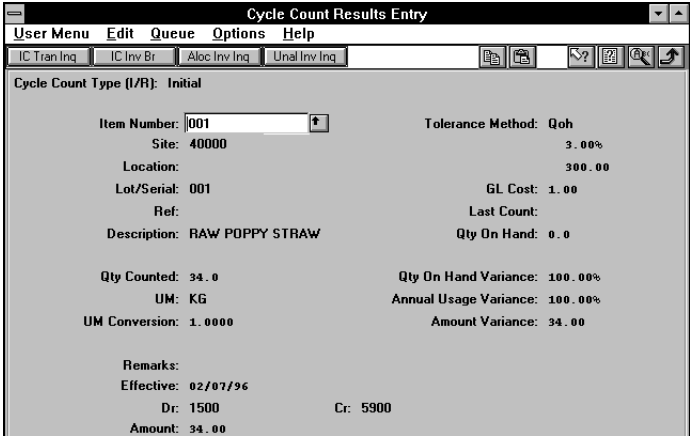

Fig. 8.3
Cycle Count Results Entry (3.14)

Entering a Recount

Use Cycle Count Results Entry (3.14) to enter recount figures. Set Cycle Count Type to R (Recount). If a recount quantity is still out of tolerance, the system alerts you to this, but nevertheless updates its figures.

Reporting Cycle Count Results

After completing the cycle count, use Cycle Count Results Report (3.15) to generate a count report showing:

- Items counted
- In-tolerance quantity
- In-tolerance percent
- Items recounted

Creating Inventory Reports

Use the reports on the Inventory Reports Menu (3.6) to check inventory statuses and values (current and GL).

Stock Status Report

Use Stock Status Report (3.6.1) to review an item's total quantity on hand and quantity on order by site. The report gives information for each location containing the item. Location information shows each item's lot/serial number, reference number, and quantity on hand.

Reorder Report

Use Reorder Report (3.6.2) to see if an item is below the reorder point or safety stock. The report shows all locations containing the item and indicates those below the reorder point or safety stock. Also shown are any open orders for the item, the quantity open, and the supplier name.

Item ABC Status Report/Update

Use Item ABC Status Report/Update (3.6.3) by product line or site to calculate item ABC class codes. Calculations can be made by a combination of either sales or issues and cost or gross profit. Three fields can be updated for existing records:

- ABC class codes
- Item average usage
- Cycle count intervals

You can also change default ABC classification percentages. Depending on the option selected, the report lists items in descending sales or issue value, and shows an item's old and new ABC classifications.

Inventory Detail Report

Use Inventory Detail Report (3.6.5) to see inventory availability status in detail or summary format. The summary report lists item inventory information at the site level:

- Quantity on hand
- Available quantity on hand
- Non-nettable quantity
- Quantity required
- Quantity allocated
- Quantity on order

The detail report adds detailed information by location within the site:

- Quantity on hand
- Quantity allocated
- Item characteristics such as expire date, grade, assay %, and inventory status

Inventory Detail by Location

Use Inventory Detail by Location (3.6.6) to see item inventory information by location:

- Quantity on hand
- Item characteristics such as expire date, grade, assay %, and inventory status

Current Surplus Inventory Report

Use Current Surplus Inventory Report (3.6.8) to review current surplus quantities and GL value by product line within a site. The system determines surplus by the absence of issue activity based on a user-specified issue date.

Reports can be generated in detail or summary format. The summary report shows information for product lines within a site. The detail report shows item information for each product line in the site. In both reports,

totals are shown for expired value and value on hand, by site and for the report.

Projected Surplus Inventory

Use Projected Surplus Inventory (3.6.9) to review projected surplus inventory for a future effective date based either on MRP requirements or average use. Choose either current cost or GL cost for surplus cost computations. For these calculations, the expiration date for items is the system date, not the effective date. You can include firm planned orders or MRP planned orders on the report, which are marked On Order.

Reports can be generated in summary or detail format. The summary shows the total expired value and ending value for each product line within a site. The detail report shows item information within each product line in the site, total expired value, ending value, quantity on order, expired quantity, and ending quantity.

Inventory Valuation Reports

Inventory valuation reports display the inventory value of quantities on hand by product line or location. Some reports show inventory values as of a specified date. You can include negative inventory in each report, and on some you can select whether items with an initial GL value of zero are valued using this initial zero or the first available cost.

- Use Inventory Valuation Report (3.6.13) to review the value of inventory in a site by product line or item number. The total value of each item is shown, with a grand total for the product line.
- Use Inventory Valuation by Location (3.6.14) to review the value of inventory in each location of a site by product line or item number. The total value of each location is shown, with a grand total for the site.
- Use Inventory Valuation as of Date (3.6.15) to review the value of all items in a product line as of a user-specified date. The total inventory in each site is shown, with a grand total for the product line.
- Use Inventory Valuation as of by Loc (3.6.16) to review the value of inventory in each location of a site on a user-specified date. The total value of each location is shown, with a grand total for the site.

Checking Inventory Availability

Use the following programs to quickly check inventory locations and:

- Use Inventory Detail by Item Browse (3.2) to see an item's total nettable and non-nettable inventory, sorted by site. Item location information is also shown.
- Use Inventory Detail by Site Browse (3.3) to see the total quantities on hand by site, sorted by item number. Item location information is also shown.
- Use Stock Availability Browse (3.17) to review stock availability in a single site or in all sites.
- Use Allocated Inventory Inquiry (3.18) to review total item quantities on hand for a site. Allocated and unallocated quantities for an item are also shown. Allocated quantity detail information includes:
 - Type of order (sales order or work order)
 - Order number
 - Quantity allocated
 - If it is a detail (Picked) or a general (Qty Alloc) allocation
- Use Unallocated Inventory Inquiry (3.19) to review non-detail-allocated inventory for a specified item, by site and location. Site information shows quantity on hand and quantity allocated. Location information shows unallocated quantity for the location. Expiration date and grade are also shown. Unallocated quantity can include quantities reserved by general allocations.

Tip
Nettable inventory is available to allocate.

Physical Inventory

This chapter explains how to use MFG/PRO eB to determine how much physical inventory is actually on hand.

| | |
|------------------------------------|------------|
| <i>Introduction</i> | 236 |
| <i>Deleting/Archiving Old Tags</i> | 236 |
| <i>Freezing Inventory Balances</i> | 237 |
| <i>Creating/Printing Tags</i> | 237 |
| <i>Entering Initial Tag Counts</i> | 238 |
| <i>Reviewing Results</i> | 239 |
| <i>Zeroing/Voiding Unused Tags</i> | 239 |
| <i>Updating Inventory Balances</i> | 240 |

Routing Maintenance (Basic Screen)

| | | |
|--------------------|---------------------|----------------------|
| Routing Code: | 10-15000 | MANUFACTURE CHBL IN |
| Operation: | 20 | |
| Standard Operation | | |
| Work Center: | 1030 | INSPECTION, ALL SITE |
| Machines: | | |
| Description: | INSPEC PER PROC-000 | |
| Machines per Op: | 1 | |
| Overlap Units: | 1 | |
| Queue Time: | 1.0 | |
| Wait Time: | 0.0 | |
| Setup Time: | 0.0 | |
| Ready Production: | | |

Introduction

▶ See “Performing Cycle Counts” on page 227 for details.

Physical Inventory enables you to count and compare actual, on-hand inventory balances with on-hand quantities maintained in MFG/PRO eB. This can also be done with cycle counting.

To perform a physical inventory count, first determine the items you want to count and the count frequency. Each item to be counted must have a system-generated count tag, used to record item count information.

The steps for conducting a physical inventory are:

- 1 Delete the tags from the previous physical inventory.
- 2 Freeze inventory balances.
- 3 Create and print tags.
- 4 Enter initial tag counts.
- 5 Review results and enter recounts if necessary.
- 6 Void/zero count unused tags.
- 7 Update inventory balances.

Deleting/Archiving Old Tags

Before creating new tags for an inventory count, delete tags from the last count using Tag Delete/Archive (3.16.23). This program:

- Deletes specified tags.
- Archives deleted tag information.
- Generates a report showing all deleted tags.

Typically, you delete only tags that have been posted using Inventory Balance Update (3.16.21).

Delete. Enter No to review tags selected for deletion without actually deleting them. The system generates a report showing tag numbers selected for deletion and whether they have been posted or voided. Enter Yes to actually delete selected tags.

Archive. Enter Yes to have deleted tag information archived.

Archive File. Enter the file to which you want the system to archive deleted tag information.

Freezing Inventory Balances

After deleting old tags, freeze the inventory to be counted using Inventory Balance Freeze (3.16.4). The system records the current quantity on hand for all selected inventory and uses this record to carry out the inventory count.

Note Freezing inventory does not prevent the system from processing regular inventory transactions. Changes to inventory during a count must be included for the count to be accurate.

Select inventory to be frozen using one or more of the following criteria:

- Site
- Location
- Product Line
- Item Number
- ABC Class

Tip

Specify a single selection (site 10000) or a range (site 10000 to 20000). To select all items, leave the range blank.

Creating/Printing Tags

Each item to be counted needs a tag showing the item's site, location, and item number. Then record count information on the tag. In the event of a recount, recount information goes on the same tag.

MFG/PROeB provides two types of count tags: item and bulk. Use Item Tag Create (3.16.1) to create tags for selected items. You can select items

by item number, site, product line, or ABC class. Enter no selection criteria to create tags for all items in the item master file.

Use Bulk Tag Create (3.16.2) to create bulk tags. Bulk tags are the same as item tags, except that the item information on bulk tags is blank. Use bulk tags to count items that do not have item tags.

To find out how many bulk tags you need, use any one of the following:

- Tag Inquiry (3.16.8)
- Tag Report (3.16.13)
- Uncounted Tag Report/Update (3.16.15)

Tip

In the event of errors, delete incorrect tags using Tag Delete/Archive (3.16.23), then recreate and print new ones.

After creating count tags, use Tag Print (3.16.6) to print both types of tags. You can print tags on most standard-size forms. Default forms are set to print on 3 x 5 inch card stock. You can optionally print the tag number in bar code format if your system is formatted to do so.

Note Before deleting bulk tags, void the tags using Tag Void Status Update (3.16.7).

Entering Initial Tag Counts

Tip

At this point, only the frozen inventory quantities are updated.

After counting tagged items, enter the count in the system using Tag Count Entry (3.16.11). Tag Count Entry accepts all quantities, even those that are out of tolerance. Enter any changes resulting from post-freeze inventory transactions.

Example The frozen quantity of Item Z is 100. After inventory freeze, 50 units of Item Z are issued. The inventory count shows 47 units of Item Z on hand. Enter a count quantity of 97 (50 + 47).

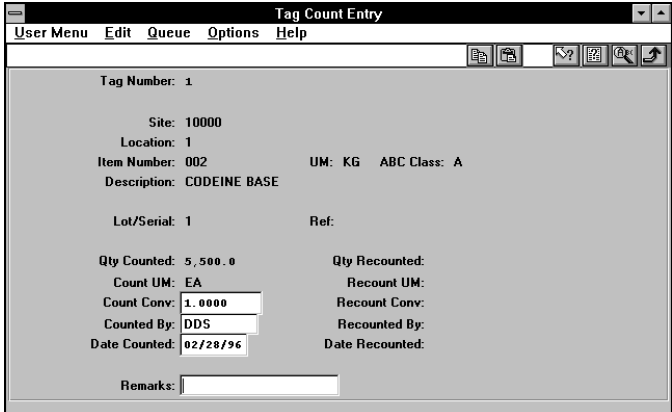

Fig. 9.1
Tag Count Entry
(3.16.11)

Reviewing Results

After entering count results, review the results using Inventory Variance Report (3.16.18). Look for out-of-tolerance quantities or other problems. You can print the report by variance amount.

Recount out-of-tolerance items. Use Tag Recount Entry (3.16.12) to enter recount information on the same item tags or bulk tags used for the initial count.

Zeroing/Voiding Unused Tags

Before a count is complete, all tags must be either counted or voided. Use Uncounted Tag Report/Update (3.16.15) to ensure that all item and bulk tags are accounted for. This report shows only tags that have not been voided or set to zero.

Set Tag Count to Zero. Some tags may be left over, either because items were not found or were counted using bulk tags. These cannot be voided. Set this flag to Yes for leftover tags.

Use Tag Void Status Update (3.16.7) to declare unused bulk tags void. Only voided bulk tags can be deleted.

Updating Inventory Balances

When all tags are accounted for and count results are satisfactory, use Inventory Balance Update (3.16.21) to update quantity-on-hand balances. The system changes each item's quantity on hand to the difference between the frozen quantity on hand and the count quantity.

Example The frozen quantity of Item Z is 100. The count quantity (50 issued, 47 counted) is 97. The update quantity is -3 . The updated quantity on hand for Item Z is 97.

SECTION 2

Global Tax Management

This section describes how to set up and use Global Tax Management (GTM).

Introduction to GTM 243

Implementing GTM 247

Processing GTM 287

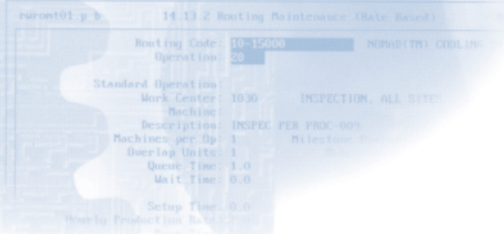

| Routing Maintenance (Main Screen) | |
|-----------------------------------|----------------------|
| Routing Code: | 10-15000 |
| Operation: | 20 |
| Standard Operation: | |
| Work Center: | 1030 |
| Machines: | INSPECTION, ALL SITE |
| Description: | INSPEC PER PROC-000 |
| Machines per Op: | 1 |
| Overlap Units: | 1 |
| Queue Time: | 1.0 |
| Wait Time: | 0.0 |
| Setup Time: | 0.0 |

Introduction to GTM

This chapter provides a general overview of the Global Tax Management (GTM) module.

Global Tax Management **244**

Tax Elements **245**

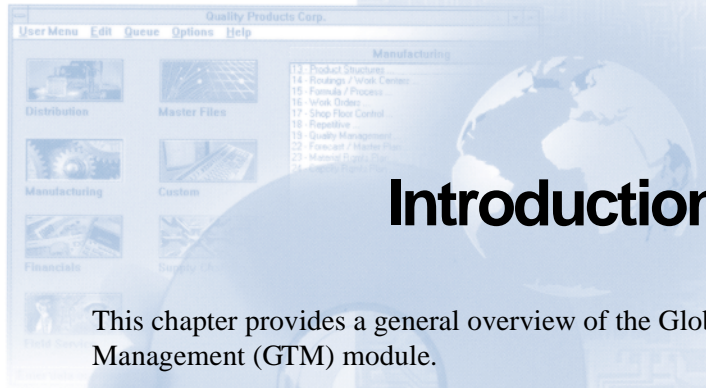

Routing Maintenance (Date Based)

| | | |
|--------------------|---------------------|-----------------------|
| Routing Code: | 10-15000 | MANUFACTURING |
| Operation: | 20 | |
| Standard Operation | | |
| Work Center: | 1030 | INSPECTION, ALL SITES |
| Machines: | | |
| Description: | INSPEC PER PROC-000 | |
| Machines per Op: | 1 | |
| Overlap Units: | 1 | |
| Queue Time: | 1.0 | |
| Wait Time: | 0.0 | |
| Setup Time: | 0.0 | |

Global Tax Management

Global Tax Management (GTM) supports multinational enterprises in calculating taxes on business transactions. The types of taxes, the formulas used to calculate them, and when taxes are assessed often vary considerably between countries. GTM can process taxes for multiple countries within the same database.

Features

GTM offers an unlimited number of taxes and rates—each associated with customers, suppliers, or items. You can also define when taxes are calculated, the formula used to calculate them, and the amount subject to tax.

GTM also supports the following situations and conditions:

- Taxes based on geographic location, effective date range, tax class, item usage, or the nature of a company's business
- Tax exemptions
- Taxation by line item or by order total
- Taxes based on a percentage of the item amount
- Trailer charges with multiple tax classes
- Luxury taxes for item amounts greater than a specified value
- Capped taxes that cannot exceed a specified maximum
- Taxes that include other tax amounts
- Purchase taxes recoverable against tax collected on sales
- Ability to override system-calculated tax amounts during transaction entry
- Reverse calculation of tax amounts from line items and trailer charges that already include tax
- Taxes your company absorbs rather than passes on to the customer
- Remittance of purchase taxes directly to the government instead of to the supplier
- Exclusion of credit term discounts from tax amounts

- Ability to generate general ledger entries for purchase taxes at receipt of goods or supplier invoice

Since GTM accommodates a variety of taxation conditions, manual overrides of automated calculations are usually not needed. Furthermore, once GTM is set up, updates are very simple.

Considerations

- To operate GTM in a multi-database distributed processing environment, GTM implementation must be identical in all databases. Multiple databases must have the same base currencies specified in the System/Account Control File (36.1).
- GTM does not currently support unit-based taxes, such as \$0.05 per can of soda.
- GTM does not calculate taxes on distribution orders generated by the Distribution Requirements Planning module. In this situation, generate sales orders instead of distribution orders.
- GTM does not adjust sales commission reporting. Commissions are always based on item prices including tax. Adjust your commission structure to compensate.

Tax Elements

Every country in the world has a unique system for assessing taxes. However, most systems share common elements:

- Business transactions can be subject to many kinds of taxes—sales taxes, domestic import duties, inventory transfer taxes, royalty fees, and so on. In GTM, a tax that is peculiar to a region and individually calculated and reported is a *tax type*.
- Regions that assess tax include countries (or groups of countries), states, provinces, counties, districts, and cities. In GTM, a region that assesses tax is a *tax zone*.
- Within a tax zone, a tax type can affect all people and items, or only some of them. In GTM, customers, suppliers, and items can be grouped by *tax class*. Similarly, a tax can be assessed at a different rate based on a customer's operation or how items are used. GTM can group people and items by *tax usage*.

- The three factors that can determine which tax types apply to a transaction are the ship-from and ship-to tax zones and the tax class of the customer or the supplier. In GTM, the set of tax types for a specific ship-to/ship-from zone and tax class combination is a *tax environment*.
- A tax type can have multiple *tax rates* for different item tax classes, tax usages, and transaction tax dates. GTM selects the rate most appropriate for a particular transaction.

Example Figure 10.1 illustrates how these factors interact. A German automobile manufacturer exports luxury cars to the United States. U.S. tax rates depend on the class of the vehicle. For example, the rate for luxury cars is 30%.

In Global Tax Management, Germany and the U.S. are tax zones. The automobile manufacturer is a customer tax class subject to the U.S. import tax. Luxury cars are an item tax class subject to a rate of 30% for the import tax. The sales order tax environment associates the import tax with the order, and GTM selects the tax rate based on the item tax class for luxury cars.

Fig. 10.1
GTM Example

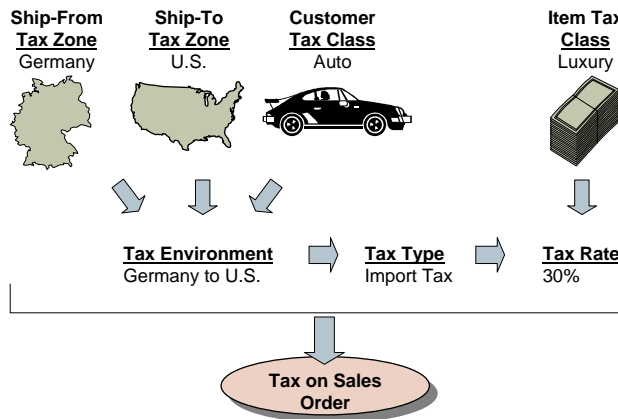

Implementing GTM

This chapter describes the data required to set up GTM and define special kinds of taxes.

| | |
|--|------------|
| <i>Implementation Overview</i> | 248 |
| <i>Setting Up Tax Jurisdictions</i> | 249 |
| <i>Setting Up Tax Types</i> | 254 |
| <i>Setting Up Tax Classes and Usages</i> | 254 |
| <i>Setting Up Rounding Methods</i> | 256 |
| <i>Setting Up Tax Environments</i> | 258 |
| <i>Setting Up Trailer Charges</i> | 261 |
| <i>Setting Up Tax Bases</i> | 263 |
| <i>Setting Up GL Accounts</i> | 265 |
| <i>Setting Up Tax Rates</i> | 266 |
| <i>Setting Up the GTM Control File</i> | 272 |
| <i>Updating Other MFG/PRO eB Records</i> | 274 |
| <i>Implementing Special Taxes</i> | 276 |

Implementation Overview

Table 11.1 lists the activities and functions used to implement Global Tax Management (GTM).

Table 11.1
Programs Used to
Implement GTM

| Activity | Use this program... |
|--|--|
| Setting up country codes | Country Code Maintenance (2.13.3.1) |
| Setting up state/province and county codes | Generalized Codes Maintenance (36.2.13) |
| Setting up tax zones | Tax Zone Maintenance (2.13.3.13) |
| Setting up tax types | Tax Type Maintenance (2.13.1.1) |
| Setting up tax classes and tax usages | Tax Class Maintenance (2.13.1.5) Tax Usage Maintenance (2.13.1.9) |
| Setting up rounding methods | Rounding Method Maintenance (2.13.1.17) |
| Setting up tax environments | Tax Environment Maintenance (2.13.5.1) |
| Setting up trailer charges | Trailer Code Maintenance (2.19.13) Trailer Tax Detail Maintenance (2.13.1.21) |
| Setting up tax bases | Tax Base Maintenance (2.13.1.13) |
| Setting up general ledger accounts | Account Code Maintenance (25.3.13) Sub-Account Code Maintenance (25.3.17) Cost Center Code Maintenance (25.3.20) |
| Setting up tax rates | Tax Rate Maintenance (2.13.13.1) Tax Rate Copy/Update (2.13.13.5) |
| Setting up the control file | Global Tax Management Control File (2.13.24) |
| Updating existing base records | Customer Maintenance (2.1.1) Supplier Maintenance (2.3.1) End User Address Maintenance (11.9.1) Product Line Maintenance (1.2.1) Item Master Maintenance (1.4.1) Service Category Maintenance (11.21.9) |

▶ See *External Interface Guide: Sales and Use Tax*.

Note U.S. and Canadian taxes can also be calculated using an external Sales and Use Tax system. In this case, GTM must be set up based on special requirements.

Setting Up Tax Jurisdictions

The first step to implementing GTM is setting up codes that define countries, states, provinces, counties, and tax zones.

Setting Up Country Codes

Records for tax zones, addresses, and transactions use alphanumeric country codes. To make data entry easier, consider using significant alphabetic rather than numeric codes.

Set up country codes in Country Code Maintenance (2.13.3.1). To verify data setup, use Country Code Browse (2.13.3.2) and Report (2.13.3.3).

Tip
The European Community (EC) and other areas may require numeric codes.

The screenshot shows a window titled "Country Code Maintenance" with a menu bar (User Menu, Edit, Queue, Options, Help) and a toolbar. The main area displays the following fields:

| | |
|-----------------|---------|
| Country Code: | BEL |
| Name: | Belgium |
| Alternate Code: | |
| EC Country: | yes |
| NAFTA Country: | no |
| DEA Country: | no |
| GATT Country: | yes |
| Country Group: | |
| Country Type: | |
| Comments: | no |

Fig. 11.1
Country Code Maintenance (2.13.3.1)

Country Code. Enter a 3-character code identifying countries specified on tax zones and address records. If a group of countries is subject to the same tax type, set up a country code for the group.

Name. Enter the name of the country. Since the name displays on printed addresses, enter the complete name of the country rather than an abbreviation. You cannot specify the same country name for two country codes.

Alternate Code. Optionally, enter an alternate code for a subgroup of countries or for sorting reports other than by country code or name. This code also can provide an alternate sort order on reports.

EC Country. This code identifies member countries of the European Union (EU). This information determines whether an inventory transaction relates to an intra-EU inventory movement that should be included in Intrastat reporting. This field is not used for GTM.

▶ See Chapter 7, "Intrastat," on page 197.

NAFTA Country. Reference only. Identifies member countries of the North American Free Trade Agreement.

DEA Country. Reference only. Identifies countries under the jurisdiction of the United States Drug Enforcement Administration.

GATT Country. Reference only. Identifies countries as members of the General Agreement on Tariffs and Trade.

Country Group. Use this field to categorize countries. Use letter codes such as those assigned by current Export Administration Regulations.

Country Type. Reference only. Use this field to categorize countries. Use letter codes such as those assigned by current Export Administration Regulations. This field is for reference only.

Comments. Enter Yes to display a screen for recording special requirements, restrictions, or other GTM specifications.

▶ See “Setting Up the GTM Control File” on page 272 for details.

After defining country codes, specify the default code for most tax zones records in the Global Tax Management Control File (2.13.24).

Setting Up State, Province, County Codes

▶ See *User Guide Volume 9: Manager Functions* for information on generalized codes.

GTM uses state/province and county codes to determine the correct tax zone for an address. If these codes are inconsistent, the system may assign the wrong tax zone. Use Generalized Codes Maintenance (36.2.13) to require users to enter a valid state, province, or county code by setting up values for fields ad_state and ad_county.

Note After you set up validation, you cannot leave these fields blank during data entry.

Setting Up Tax Zones

Tax zones identify geographic regions subject to the same set of tax types and levels of tax reporting. All customer, supplier, and company address records belong to a tax zone. On sales, purchasing, and other transactions, the system uses tax zones to determine the tax environment.

A separate tax zone is required for each country, state, province, county, city, and postal zone that has distinct tax reporting requirements. Since one tax zone can include reporting and tax calculations for another, tax

zones are organized into hierarchies. Set up higher-level zones before lower-level ones. For example, set up countries before their component states, states before counties, and so on.

Tax Zone Hierarchies

How you set up a tax zone depends on its position in the hierarchy. To include a tax zone in the tax total and reporting for another zone, specify the first zone's *sums-into* zone. The sums-into zone can be at a higher level or at the same level.

For example, a city tax zone included in provincial tax reporting sums into the provincial tax zone. Or, a tax zone for a suburb included in metropolitan tax reporting sums into the city tax zone. In the tax zone record, specify whether the first zone has its own subtotal on the main report and whether it also has its own reporting.

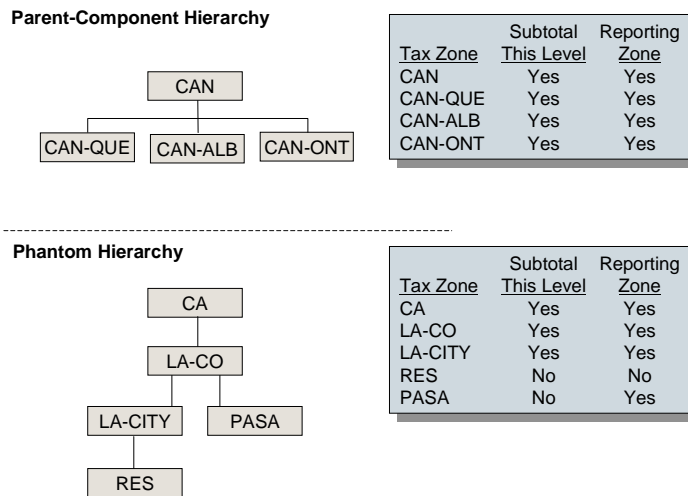

Fig. 11.2
Tax Zone Hierarchies

Figure 11.2 illustrates two hypothetical tax zone hierarchies.

- Parent-Component Hierarchy.** The Canadian provinces Quebec, Alberta, and Ontario are subject to both federal and provincial taxes. The component tax zones CAN-QUE, CAN-ALB, and CAN-ONT sum into zone CAN. All four zones are reporting zones in their own right and are subtitled.

- *Phantom Hierarchy.* Reseda, a suburb of Los Angeles, is taxed in the same way as Los Angeles and does not have a subtotal on the city tax report. Tax zone RES sums into LA-CITY but is not subtotaled and is not a separate reporting zone.

Pasadena is subject to Los Angeles county tax and does not have a subtotal on the county tax report. Tax zone PASA sums into zone LA-CO. It is not subtotaled but is a distinct reporting zone.

Tax Zone Maintenance

Set up tax zones in Tax Zone Maintenance (2.13.3.13). To verify data setup, use Tax Zone Browse (2.13.3.14) and Report (2.13.3.15). To verify sums-into relationships, use Tax Hierarchy Browse (2.13.3.17) and Report (2.13.3.18).

Fig. 11.3
Tax Zone
Maintenance
(2.13.3.13)

The screenshot shows a software window titled "Tax Zone Maintenance". The window has a menu bar with "User Menu", "Edit", "Queue", "Options", and "Help". Below the menu bar is a toolbar with several icons. The main content area is divided into two sections. The top section displays the following information: "Tax Zone: CAN-ONT", "Description: Ontario, Canada", "Country Code: CAN", "State: ONT", "County:", "City:", "Post:", "Subtotal This Level: yes", and "Reporting Zone: yes". The bottom section is titled "Sums-Into Tax Zone" and contains a dropdown menu with "CAN" selected, followed by "Description: Canada", "Country Code: CAN", "State:", "County:", "City:", and "Post:".

Tax Zone. Enter a 16-character code to identify a unique geographic region for tax types. Set up tax zones for every level at which separate tax calculations and reporting are required, starting with the top level and working downward. For example, set up countries before states, states before counties, and so on.

Description. Enter the description of the tax zone. You are not prevented from entering the same description for multiple tax zones. The description prints on most reports and browses, as space permits.

Country Code. This code identifies the country that assesses tax. For new tax zones, the value defaults from the Global Tax Management Control File (2.13.24).

State. Enter the code for the state or province included in the tax zone.

County. Enter the code for the county included in the tax zone.

City. Enter the name of the city included in the tax zone.

Post. If necessary, enter the postal code included in the tax zone. If taxes never vary by postal code, do not set up tax zones by postal code.

Subtotal This Level. Enter Yes or No to determine whether custom tax reports can show subtotals for this tax zone. No standard reports show tax amounts by tax zone.

Reporting Zone. Enter Yes or No to identify whether the tax zone directly assesses tax.

Sums-Into Tax Zone. Enter a code identifying the parent tax zone that actually assesses tax for the geographic region defined above. The description, country code, state, county, city, and postal code display.

In addition to the geographic tax zone codes, set up an error code and specify it in the Global Tax Management Control File (2.13.24). When you enter or update an address record, GTM attempts to match the address to a tax zone for the country, state/province, county, and city. If it cannot find a tax zone for the country, it assigns the error zone.

To make it easier to identify error conditions, set up a meaningful code, such as ERROR-ZONE.

▶ See “Setting Up the GTM Control File” on page 272.

Setting Up Tax Types

Tax types are individually calculated and reported as regional taxes or tax exemptions. Examples include Canadian PST/GST, California sales tax, federal excise tax. On transactions, the system calculates taxes for line items and trailer charges based on the tax types specified in their tax environments.

Tip
Preface the type with the country code or state/province.

A separate tax type is required for each tax or tax exemption you report separately. The tax detail reports print in alphanumeric order by tax type code. Consider this when assigning codes for tax types.

Set up tax types in Tax Type Maintenance (2.13.1.1). To verify data setup, use Tax Type Browse (2.13.1.2) and Report (2.13.1.3).

Fig. 11.4
Tax Type Maintenance (2.13.1.1)

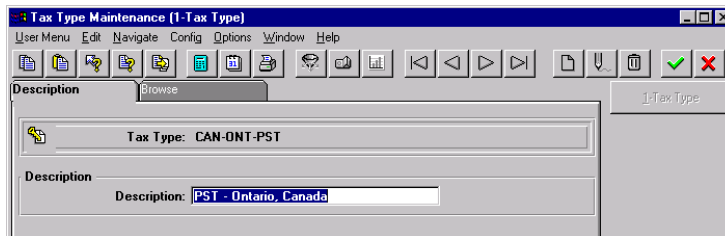

Tax Type. Enter a 16-character code for a tax or tax exemption that is separately calculated and reported to a specific jurisdiction.

Description. Enter the description of the tax type. Description prints on most reports and browses, as space permits.

Setting Up Tax Classes and Usages

Depending on your tax system, set up tax class and/or tax usage codes to accommodate differences in taxation within a tax zone. Table 11.2 lists some typical situations and describes how to implement them.

| Situation | Implementation |
|---|---|
| Customers and/or suppliers in a tax zone are subject to different tax types or tax exemption types. | Set up tax classes for these customers and/or suppliers. |
| Product lines and/or items are subject to different tax types or tax exemption types. | Items are always subject to the tax types in the line item tax environment. There is no way to override this. You can set up tax classes for product lines and items. However, they are only used to select tax rates. |
| On sales transactions, trailer charges are subject to different tax types or tax exemption types. | Trailer charges are always subject to the tax types in the transaction tax environment. There is no way to override this. You can set up tax classes for trailer charges; however, they are only used to select tax rates. |
| Customers and/or suppliers are subject to different tax rates for a tax type. | Set up tax usages for these customers and suppliers. |
| Items are subject to different tax rates for a tax type. | If items have the same rates on all transactions, set up tax classes. However, if rates can differ by transaction, based on the intended usage of the item, set up the tax usage codes to reference during transaction entry. |
| Trailer charges are subject to different tax rates for a tax type. | Set up tax classes for these trailer charges. |

Table 11.2
Tax Classes vs Tax Usages

Set up tax class codes in Tax Class Maintenance (2.13.1.5). To verify data setup, use Tax Class Browse (2.13.1.6) and Report (2.13.1.7).

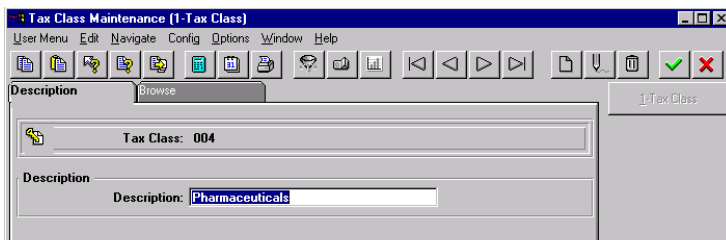

Fig. 11.5
Tax Class Maintenance (2.13.1.5)

Tax Class. Enter a 3-character code that identifies a group of customers, suppliers, product lines, items, service categories, or trailer charges subject to special taxation.

- For customers and suppliers, the tax class helps determine the tax environment.
- For product lines, the tax class determines the tax rate for new items.
- For items, service categories, and trailer charges, the tax class helps determine the tax rate for tax types in the tax environment.

For more detailed tax exemption reporting, remember to set up tax classes for exemptions.

Description. Enter a description of the tax class. The description prints on most reports and browses, as space permits.

Set up tax usage codes in Tax Usage Maintenance (2.13.1.9). To verify data setup, use Tax Usage Browse (2.13.1.10) and Report (2.13.1.11).

Fig. 11.6
Tax Usage
Maintenance
(2.13.1.9)

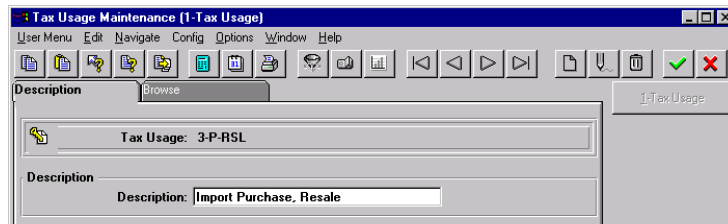

Tax Usage. Enter an 8-character code that identifies a group of customers, suppliers, or items subject to special taxation on a specific transaction.

Description. Enter a description of the tax usage. The description prints on most reports and browses, as space permits.

Setting Up Rounding Methods

During transaction entry, the system calculates numbers that must be rounded up or down to the nearest tenth, hundredth, or other unit before they can be printed on reports or displayed on the screen.

Rounding conventions vary by country and tax requirements. In GTM, you can define multiple rounding methods and assign the appropriate one to each tax type in the tax environment.

Three rounding methods are supplied:

- 0 (rounding to ones)
- 1 (rounding to tenths)
- 2 (rounding to hundredths)

If you need additional rounding methods, define them in Rounding Method Maintenance (2.13.1.17). To verify data setup, use Rounding Method Browse (2.13.1.18) and Report (2.13.1.19).

Note Rounding methods can also be associated with currencies. Rounding Method Maintenance is also available as option 36.2.9.

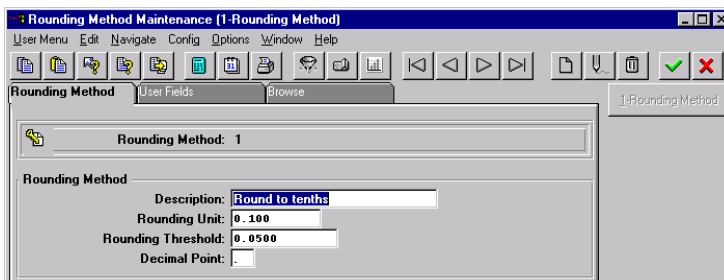

Fig. 11.7
Rounding Method
Maintenance
(2.13.1.17)

Rounding Method. Enter a 1-character numeric code that identifies a method for rounding calculated amounts. Codes 0, 1, and 2 are system supplied.

Description. Enter a description of the rounding method. The description prints on most browses and reports, as space permits.

Rounding Unit. The rounding unit must be an integer or a decimal that is a power of 10 multiplied by the numbers 1 or 5. Common rounding units are 1, 10, 0.01, and 0.10. You cannot change the rounding unit for standard methods 0, 1, and 2.

Rounding Threshold. Specify the point at which transaction tax amounts are rounded up or down. For methods 0, 1, and 2, the default rounding thresholds are 0.5, 0.05, and 0.005, respectively. Amounts less than these thresholds are rounded down, and amounts higher than or equal to higher amounts are rounded up.

The rounding threshold can be any number for rounding to the nearest dime, nickel, quarter, centavo, pfennig, and so on. Rounding is based on the absolute value of the amount to be rounded. (-9.99 rounds to

–10.0 just as 9.99 rounds to 10.0.) You can change the rounding threshold for standard methods 0, 1, and 2.

Decimal Point. Specify whether the decimal point is a period or a comma.

Setting Up Tax Environments

Transactions are subject to the tax laws of both your company and the customer or supplier. Before the system calculates taxes, it determines which taxes (state sales tax, local tax, VAT, and so on) apply to the addresses that ship and receive the goods.

A tax environment is the set of tax types that applies to a combination of ship-from and ship-to tax zones and optionally a customer or supplier tax class.

Before you set up tax environments, identify the combinations of tax types that apply to transactions. Then, determine the tax zones and customer/supplier tax classes that are subject to these tax groups.

You can simplify setup of tax environments. If all shipments to or from a tax zone are taxed the same way, leave the tax zone blank. You may be able to specify a *sums-into* tax zone that encompasses many lower-level zones. Finally, you can leave the tax class blank if the tax types apply to all customers and suppliers in the indicated tax zones.

Each tax type in the environment has a calculation sequence and rounding method. The sequence determines the priority for calculating taxes when there are multiple tax types in the environment. The rounding method determines how the tax type is rounded.

Example Suppose that shipments that start and end in the U.S. state of Florida can be subject to (1) state tax only, (2) state and county tax, or (3) state, county, and city tax. Sample tax environments are illustrated in Tables 11.3 through 11.5. The tax types apply to all tax zone combinations in the environments.

| Ship-From Zone | Ship-To Zone | Tax Class | Tax Type | Sequence | Rounding |
|----------------|--------------|-----------|----------|----------|----------|
| FL | FL | - | FL-STATE | 1 | 2 |
| | | DRUG | | | |
| | | FOOD | | | |

Table 11.3
Default Florida State Tax Environment (1)

| Ship-From Zone | Ship-To Zone | Tax Class | Tax Type | Sequence | Rounding |
|----------------|--------------|-----------|----------|----------|----------|
| FL | FL-ALTSP | - | FL-STATE | 1 | 2 |
| FL | FL-LMARY | DRUG | FL-SEMCO | 2 | 2 |
| FL | FL-LONGW | FOOD | | | |
| FL | FL-SANFO | | | | |
| FL | FL-WINSP | | | | |

Table 11.4
Environment for Cities Subject to Florida Tax and Seminole County Tax (2)

| Ship-From Zone | Ship-To Zone | Tax Class | Tax Type | Sequence | Rounding |
|----------------|--------------|-----------|----------|----------|----------|
| FL | FL-APOPK | - | FL-STATE | 1 | 2 |
| FL | FL-LUNDE | DRUG | FL-ORACO | 2 | 2 |
| FL | FL-OCOEE | FOOD | FL-ORLAN | 3 | 2 |
| FL | FL-OVIED | | | | |
| FL | FL-WINPK | | | | |

Table 11.5
Environment for Cities Subject to Florida Tax, Orange County Tax, and Orlando City Tax (3)

Set up tax environments in Tax Environment Maintenance (2.13.5.1). To verify data setup, use Tax Environment Browse (2.13.5.2) and Report (2.13.5.3).

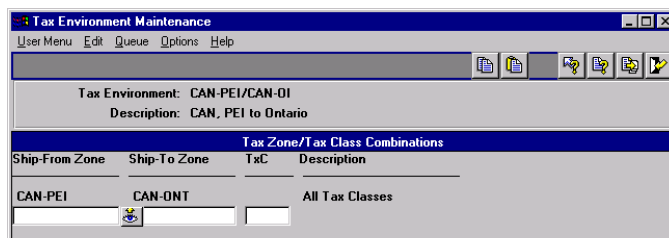

Fig. 11.8
Tax Environment Maintenance (2.13.5.1), Tax Zones/Tax Class Combinations

Tax Environment. Enter a 16-character code that identifies a set of tax types for a tax zone/tax class combination. On transactions, this code identifies the transaction or line item tax environment.

Description. Enter a description of the tax environment. Unique descriptions make selecting zones easier, but the system does not prevent you from entering the same description for multiple tax environments. The description prints on most reports and browses, as space permits.

Ship-From Zone. You can specify the tax zone from which goods are shipped. However, if all shipments to the environment's ship-to zone are taxable regardless of origin, leave the ship-from zone blank.

Ship-To Zone. You can specify the tax zone to which goods are shipped. However, if all shipments from the environment's ship-from zone are taxable regardless of destination, leave the ship-to zone blank.

TxC (Tax Class). You can enter tax classes for customers and/or suppliers subject to the tax types in the environment. If all shipments are taxable regardless of customer or supplier, leave the tax class blank. Do not enter item tax classes; GTM only uses these to select tax rates.

Description. This field contains a description of the combination of ship-from, ship-to, and tax class.

Fig. 11.9
Tax Environment
Maintenance
(2.13.5.1), Tax
Types, Sequences,
and Rounding
Methods

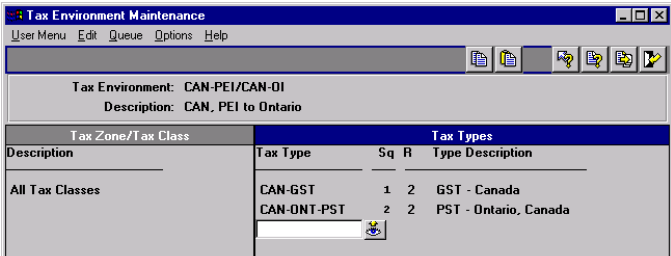

The screenshot shows a window titled "Tax Environment Maintenance" with a menu bar (User Menu, Edit, Queue, Options, Help) and a toolbar. The main area displays "Tax Environment: CAN-PEI/CAN-OI" and "Description: CAN, PEI to Ontario". Below this is a table with two main columns: "Tax Zone/Tax Class" and "Tax Types".

| Description | Tax Types | | |
|-----------------|-------------|----|---|
| | Tax Type | Sq | R |
| All Tax Classes | CAN-GST | 1 | 2 |
| | CAN-ONT-PST | 2 | 2 |

The "Tax Types" column also includes a "Type Description" sub-column. For CAN-GST, the description is "GST - Canada". For CAN-ONT-PST, the description is "PST - Ontario, Canada".

Tax Type. Enter the type codes to include in the environment. The codes you enter apply to all combinations of ship-firms, ship-tos, and tax classes in the environment.

Seq (Sequence). Specify the priority in which tax types are calculated in a tax environment. The tax type that is calculated first must have a lower sequence number than the other tax type. If all taxes are calculated independently of each other, leave the sequence number for all tax types set to 1.

In tax-on-tax situations in which a tax includes another tax amount, enter a lower sequence number for the tax that is calculated first. For example, in some Canadian provinces, provincial sales tax (PST) is based on the item amount plus the goods and services tax (GST). GST has a lower sequence number than PST.

▶ See “Tax-on-Tax” on page 281.

R (Rounding Method). Rounding method determines how tax amounts for the tax type are truncated. The rounding method defaults from the Global Tax Management Control File (2.13.24), but you can override it if the tax type requires a different method.

Type Description. This field contains the tax type description.

In addition to the other tax environment codes, set up an error code and specify it in the Global Tax Management Control File (2.13.24). When you enter a transaction, GTM attempts to match the ship-to/ship-from tax zones and customer or supplier tax class to a tax environment. If it cannot find one, it assigns the error environment. To make it easier to identify error conditions, set up a meaningful code such as ERROR-ENVIRON.

▶ See “Setting Up the GTM Control File” on page 272.

Setting Up Trailer Charges

Sales transactions often have additional charges such as freight, service, and labor that are independent of individual line items. In MFG/PRO eB, these charges are known as trailer charges because they appear at the end of the transaction.

Each trailer charge has a default taxable status and an optional default tax class. This information is defined in the trailer code record. However, in GTM, you can also set up trailer charge detail records to support exception conditions when a trailer charge has a different taxable status and/or tax rate for some tax types and customer tax classes.

Example If service charges are normally exempt from California sales tax but professional services are taxable at 5%, you can set this up in at least two ways.

- If you defined tax types for tax exemptions, define a taxable trailer code. Set up a taxable trailer tax detail for the tax type/tax class combination. Finally, set up a 0% tax rate for exempt trailer charges and a 5% rate for the professional services class.

- If you plan to report all exempt amounts under tax type NON-TAX, define a non-taxable trailer code. Set up a taxable trailer tax detail for the tax type/tax class combination. Finally, set up a 5% tax rate for the professional services class. You do not need a 0% tax rate because this is supplied by default.

If you have not already implemented trailer code records, do so in Trailer Code Maintenance (2.19.13). Then, identify the exception conditions and set up the corresponding records in Trailer Tax Detail Maintenance (2.13.1.21). To verify data setup, use Trailer Code Browse (2.19.14) for trailer codes and the Trailer Tax Detail Browse (2.13.1.22) and Report (2.13.1.23) for trailer tax details.

Fig. 11.10
Trailer Tax Detail
Maintenance
(2.13.1.21)

The screenshot shows a software window titled "Trailer Tax Detail Maintenance (1-Trlr Tax Dtl Mnt)". The window has a menu bar with "User Menu", "Edit", "Navigate", "Config", "Options", "Window", and "Help". Below the menu bar is a toolbar with various icons. The main content area is divided into several sections. At the top, there is a "Trailer Tax Code" section with a "Browse" button. Below this, there are two columns of information: "Trailer Code: 10" and "Tax Type: CAN-ALB-PST" on the left, and "Service: PST - Alberta, Canada" on the right. Below these, there is another "Trailer Tax Code" section with a checked "Taxable" checkbox and "Tax Class: 005".

Trailer Code. Enter a trailer code previously set up in Trailer Code Maintenance (2.19.13). You can set up trailer tax details for a maximum of 99 trailer codes. However, you can set up an unlimited number of trailer tax details per trailer code.

Tax Type. Specify the tax type subject to special treatment for this trailer charge.

Taxable. Specify whether amounts for this trailer code are taxable for the tax type/tax class combination.

Tax Class. If applicable, enter the tax class subject to special treatment for this trailer charge.

Setting Up Tax Bases

By default, tax is based on 100% of the item amount, exclusive of any other tax amounts. However, an item's tax can be based on some amount that is greater or less than the item amount. In these situations, set up a tax base record.

A tax base record is required whenever tax is based on a percentage of the item amount. A tax base is also required whenever tax is based on the item amount plus a previously calculated tax amount. This situation is sometimes called *tax-on-tax*.

▶ See "Tax-on-Tax" on page 281.

Example

- In Brazil, whenever you sell an old fixed asset and replace it with a new one, tax is assessed on a percentage of the old asset's sale price.
- In some Canadian provinces, PST (Provincial Sales Tax) includes the GST (Goods and Services Tax) in the taxable base for PST.

Assign a tax base to multiple tax types and tax rates if the percentage of value is the same for all situations. When you assign a tax type to a tax base, the tax base becomes part of all tax environments that use tax type.

Set up tax bases in Tax Base Maintenance (2.13.1.13), shown in Figure 11.11. To verify data setup, use Tax Base Browse (2.13.1.14) and Report (2.13.1.15).

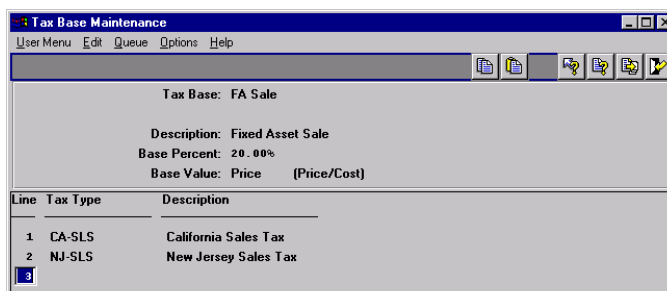

Fig. 11.11
Tax Base Maintenance
(2.13.1.13)

Tax Base. Enter an 8-character code that describes an item amount subject to tax. This amount can either be a percentage of sales price or the sales price plus other tax amounts. For a tax-on-tax situation, set up the tax base for the tax that is included in the taxable base for the other tax.

Once you start processing transactions with GTM, a warning message displays if you try to update a tax base that has already been used in other records.

Description. Enter the description of the tax base. The description prints on most reports and browses, as space permits.

Base Percent. Identify the percentage of the item's price or cost to use in tax calculations for this tax base. The default value is 100%. Percentages can be either positive or negative. Negative percentages indicate tax credits. The base percent must be the same for all tax types assigned to the tax base. Otherwise, you must set up separate tax bases.

On transactions, the system uses the base percent for the tax type to calculate the taxable base amount for each line item or trailer charge.

Base Value. Identify the type of item amount for the taxable base. *Do not change this setting.* The only supported type is sales price. Line item and trailer charge amounts are taxed based on the price at which you buy or sell them. GTM does not support tax based on general ledger cost.

Line. The system automatically assigns a line number when you assign a tax type to the tax base. Assign up to 99 tax types to a tax base. When you add a new tax base, the system assigns the next sequential line number. To display a previously entered tax type, enter its line number. To delete a line, press F5 or Ctrl+D.

Tax Type. Assign the tax base to its tax types. During tax calculations, the tax rate for the tax type is applied to the taxable base portion of the item amount.

Description. This field contains a description of the tax type.

Setting Up GL Accounts

GTM calculates tax amounts separately for each tax rate. Before you set up tax rate records, verify that you have all the necessary tax accounts, sub-accounts, and cost centers in the general ledger (GL) chart of accounts. If any are missing, set them up.

Depending on the nature of your tax rates, some or all of the tax amounts listed in Table 11.6 are represented in the general ledger.

Table 11.6
Tax Amounts
Posted to GL

| Amount | Explanation |
|--------------------|---|
| Sales tax | A liability credited for sales tax payable. It is updated by Invoice Post (7.13.4) and AR DR/CR Memo Maintenance (27.1). |
| Sales tax absorbed | A liability credited whenever your company absorbs tax instead of charging it to the customer. This occurs, for example, when your company gives an item to a customer but you still pay tax on it even though the sales price is zero. It is updated by Invoice Post (7.13.4) and DR/CR Memo Maintenance (27.1). |
| Recoverable tax | An asset debited for recoverable amounts or a liability when treated as a contra account to sales tax payable. It is updated by Purchase Order Receipts (5.13.1), PO Shipper Receipt (5.13.20), and confirmed AP vouchers (28.1, 28.6, 28.7). |
| Retained tax | A liability credited when you withhold tax on purchases and remit it directly to the government instead of to the supplier. It is updated by Purchase Order Receipts (5.13.1), PO Shipper Receipt (5.13.20), and the AP voucher confirmation programs (28.6, 28.7). |

The relevant general ledger maintenance functions are as follows:

- Account Code Maintenance (25.3.13)
- Sub-Account Code Maintenance (25.3.17)
- Cost Center Code Maintenance (25.3.20)

▶ See *User Guide Volume 4A: Financials*.

To verify data setup, use browse and report programs in the General Ledger Setup Menu (25.3).

After you update your chart of accounts, specify the default codes for new tax rate records in the System/Account Control File (36.1). If necessary, you can later override these codes for individual tax rates.

Setting Up Tax Rates

GTM tax rate records enable you to configure the software to support many different kinds of taxes and transaction conditions. The major decision points are as follows. Not all decisions apply to all tax types in all countries.

▶ See “Implementing Special Taxes” on page 276.

- The tax type, tax class, tax usage, and starting/ending date range to which the tax rate applies
- The percentage used to calculate tax
- Whether taxes are calculated by item or by transaction total
- The taxable base, or item amount subject to tax
- The minimum/maximum item amounts subject to tax
- The amount of purchase tax that is recoverable against sales tax
- The tax calculation method
- Whether a user can override system-calculated tax amounts
- Whether tax amounts are reverse-calculated from item amounts that already include tax
- The GL accounts, sub-accounts, and cost centers to which tax amounts involving this tax rate are posted
- Whether the tax on purchased items sold as part of a service contract are absorbed rather than collected
- Whether purchase tax amounts are retained and paid directly to the government rather than remitted to suppliers
- Whether purchase taxes are accrued for GL reporting upon receipt of goods or the supplier invoice
- Whether taxes are based on sales minus credit terms discounts or on the full sales amount

Note Set up tax rates by tax class or tax usage only for exception conditions. Otherwise, leave these fields blank so that the system can apply the tax rate to as many transactions as possible.

Before you set up tax rate records, define the following default values in the Global Tax Management Control File (2.13.24). For more information on these fields, see the indicated pages:

▶ See “Setting Up the GTM Control File” on page 272.

- Tax Method (page 269)
- Tax-By-Line (page 268)
- Accrue Tax at Receipt (page 270)
- Discount Tax at Invoice (page 270)
- Discount Tax at Payment (page 271)
- Update Tax Allowed (page 269)

You can later override these values for individual tax rates. Subsequent changes to the control file do not update existing rates.

Tax Rate Maintenance

To define tax rates, use Tax Rate Maintenance (2.13.13.1). To verify data setup, use Tax Rate Browse (2.13.13.2) and Report (2.13.13.3).

Note If you change a tax rate once you start using it on transactions, a warning displays. The system recalculates taxes on open transactions whenever you access the transaction record.

Fig. 11.12
Tax Rate Maintenance (2.13.13.1)

Tax Type. Enter the tax type to which the rate applies.

Item Tax Class. If the tax rate applies only to a specific line item or trailer charge tax class, enter it here. Leave this field blank if the tax rate applies regardless of tax class. Do not set up rates by customer or supplier tax class.

Tax Usage. If the tax rate applies only to a specific tax usage, enter it. Leave blank if the tax rate applies regardless of tax usage.

Effective. Specify the starting date for using this tax rate in tax calculations. If you do not specify a date, the system inserts the record creation date. When you enter multiple tax rates, the default effective date is the one in the last record entered.

Tax Code. Enter a code identifying this tax rate. If you do not enter a code, the system increments it automatically from the Last Tax Code in the Global Tax Management Control File (2.13.24). You can use prefixes to designate groups of tax rates, but be aware that future tax rates will have the same prefix unless you override it. Tax code has no significance for auditing or accounting purposes.

Description. Enter the description of the tax rate. Description prints on most reports and browses, as space permits.

Tax Rate. Specify the percentage used to calculate tax amounts for this tax rate. How the rate is used in the calculation depends on the tax method specified. To use tax types to report tax exemptions, also set up zero-percent tax rates.

Tax-By-Line. Specify whether taxes on line item amounts are calculated individually or by order total. On sales transactions, taxes on trailer charges are always totaled for the order regardless of the Tax-By-Line setting. This setting has no influence on accounts receivable and accounts payable tax calculations; debit/credit memos always calculate tax by total and vouchers always calculate by line.

Tax Base. If necessary, enter the code that identifies the portion of the item amount subject to taxation. Leave this blank if the taxable base for this tax rate is always 100% of the item price.

Min. Taxable. If necessary, enter the minimum transaction taxable base amount to which this tax rate should be applied. How this field is used in tax calculations depends on the tax method specified. Leave blank if the tax rate applies equally to all item amounts.

▶ See “Tax Based on Partial Item Amounts” on page 278.

▶ See “Luxury Taxes” on page 280.

Max. Taxable. If necessary, enter the maximum transaction taxable base amount to which this tax rate should be applied. How this field is used in tax calculations depends on the tax method specified. Leave blank if the tax rate applies equally to all item amounts.

▶ See “Capped Taxes” on page 280.

Percent Recoverable. Specify a recoverable tax percentage if you are able to offset some or all purchase tax amounts for this rate against the amounts for this rate that you collect on sales. Otherwise, leave set to 0.00%.

▶ See “Recoverable Taxes” on page 280.

Tax Method. Specify which calculation routine to use when this tax rate is applied. The standard tax methods are 01, 02, 11. If you leave this field blank, calculation method 01 is assumed.

If you are using the Sales and Use Tax Interface, specify tax method 20. If you are importing tax amounts from an external system and do not want to recalculate them, specify method 03.

You can also define custom methods, but be sure to follow the program naming convention.

▶ See page 278.

Update Tax Allowed. Decide whether users can modify system-calculated taxable base and tax amounts during transaction entry. This feature is useful for overriding the system if there is a need to match amounts on manually issued documents. However, the system does not maintain an audit trail of changes. In some environments, the government may require you to set this to No.

▶ See “Correcting Transaction Tax Amounts” on page 295.

Allow Tax Included. Specify whether this tax rate reverse-calculates taxes from line item and trailer charge amounts on transactions for customers and suppliers whose Tax In (tax included) status is Yes. If you set Allow Tax Included to Yes, GTM reverse-calculates tax based on the tax rate’s percentage and tax method.

▶ See “Reverse-Calculated Taxes” on page 283.

EC Sales List. This setting is used only on tax rates for European Community countries with recoverable value-added taxes. If Yes, sales and purchases that use these tax rates are included in the EC Sales Listing (2.13.15.8), a report submitted to the government as verification that recoverable purchase VAT claimed back by your company is correct for the amount of VAT it collected on sales.

EC Process Work. This setting identifies tax rates that apply to work performed in another European Community country.

Sales Tax Account. Identify the sales tax liability credited whenever tax is calculated on sales to a customer. Account, sub-account, and cost center default from the System/Account Control File (36.1), but you can override them.

▶ See “Absorbed Taxes” on page 283.

Sales Tax Absorbed. Identify the sales tax liability credited whenever your company pays tax instead of charging it to the customer. If the tax rate is for an absorbed tax, set to Yes. Account, sub-account, and cost center default from the System/Account Control File (36.1), but you can override them.

AP Tax Account. Identify the asset debited for recoverable purchase and accounts payable taxes, or liability when treated as a contra account to sales tax payable. Account, sub-account, and cost center default from the System/Account Control File (36.1), but you can override them.

▶ See “Retained Taxes” on page 283.

AP Tax Retained. Identify the liability account credited whenever your company remits tax amounts directly to the government instead of to the supplier. If the tax rate is for a retained tax, set this option to Yes. Account, sub-account, and cost center default from the System/Account Control File (36.1), but you can override them.

Expiration Date. Use this field to phase in expiration dates for obsolete tax rates. This date is the last day when the tax rate can be used on transactions.

▶ See “General Ledger Effects” on page 296.

Accrue Tax at Receipt. This setting determines whether the system creates GL entries for purchase tax amounts upon receipt of goods or receipt of the supplier invoice. By default, the tax point is goods receipt. However, for recoverable tax rates, set Accrue Tax at Receipt to No, because you cannot deduct the recoverable portion of tax paid on purchases against tax collected on sales until you confirm the voucher for the supplier invoice.

The tax point does not affect tax calculations on transactions. The tax amounts display regardless of when the GL entries are created.

▶ See “Discounted Taxes” on page 282.

Discount Tax at Invoice. This setting determines whether the tax rate calculates taxes based on the sales amount minus credit terms discounts, but displays an order net total of full sales amount plus discounted tax amount. If tax is based on the full sales amount, set this to No.

Discount Tax at Payment. This setting is similar to Discount Tax at Invoice, except that the net order total is the discounted sales amount plus the discounted tax amount.

Comments. Set to Yes to record transaction comments for the tax rate. This is useful for recording government regulations and other legally required text for tax reports.

Tax Rate Copy/Update

To streamline the task of entering tax rates, group the required rates for a tax type/item tax class/tax usage/effective date combination. Set up a generic rate first, then copy with Tax Rate Copy/Update (2.13.13.5) and customize it as necessary.

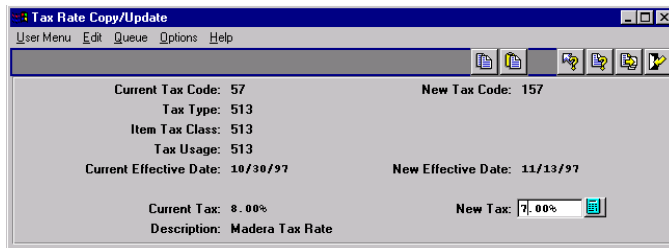

Fig. 11.13
Tax Rate Copy/
Update (2.13.13.5)

Current Tax Code. Enter the tax code of the tax rate to copy. The tax type, item tax class, tax usage, current effective date, current tax rate percentage display for the selected rate.

New Tax Code. Leave blank for the system to assign the next available tax code, incremented from the Last Tax Code value in the Global Tax Management Control File (2.13.24). Alternately, enter a previously unassigned value.

New Effective Date. Specify the starting date for using the new tax rate in tax calculations. If you do not specify a date, the system inserts the record creation date. When you enter multiple tax rates, the default effective date is the one in the last record entered.

New Tax. Enter the percentage for the new tax rate.

Tax Rate Copy/Update redisplay information from the source tax rate and allows you to customize settings.

Setting Up the GTM Control File

In the Global Tax Management Control File (2.13.24), enter the following values to complete setup of the control file.

Fig. 11.14
Global Tax
Management
Control File
(2.13.24)

The screenshot shows a window titled "Global Tax Management Ctrl File" with a menu bar (User Menu, Edit, Queue, Options, Help) and a toolbar. The main area contains the following settings:

| | |
|----------------------------|--------------|
| Tax Zone: | ERROR-ZONE |
| Tax Environment: | RRDR-ENVIRON |
| Country Code: | USA |
| Rounding Method: | 2 |
| Tax Method: | 01 |
| Tax-By-Line: | yes |
| Accrue Tax at Receipt: | yes |
| Discount Tax at Invoice: | no |
| Discount Tax at Payment: | no |
| Update Tax Allowed: | no |
| Update History Allowed: | no |
| Keep Tax History: | yes |
| Validate VAT Registration: | no |
| Print VAT Registration: | no |
| Display Detail on Reports: | yes |
| Last Tax Code: | |

These fields affect tax history and reporting.

Tax Zone. Enter the default tax zone to be used during transaction entry when the system cannot find a matching tax zone for an address record.

Tax Environment. Enter the default tax environment to be used during transaction entry when the system cannot match the ship-to/ship-from tax zones and customer or supplier tax class to a tax environment.

Country Code. Enter a code to display as the default in Tax Zone Maintenance. This code represents the top-level in the tax zone hierarchy.

Rounding Method. Enter the default rounding method for tax types in Tax Environment Maintenance. Rounding method determines how tax amounts for the tax type are truncated.

See "Tax Rate Maintenance" on page 267.

Tax Method, Tax-By-Line, Accrue Tax at Receipt, Discount Tax at Invoice, Discount Tax at Payment, Update Tax Allowed. These fields all set defaults for the corresponding fields in Tax Rate Maintenance.

Update History Allowed. This setting determines whether users can change tax history detail records. This setting is relevant only if Keep Tax History is also Yes.

Keep Tax History. This setting determines whether the system creates tax history records. Tax history records are always created on a per-item basis. This setting must be Yes if Update History Allowed is Yes.

Validate VAT Registration. Enter Yes for the system to validate that VAT registration numbers are in one of the required formats for European Union countries. Validation occurs when they are recorded in the Address Tax Window of various address maintenance programs.

▶ See Table 11.7 on page 275 for a list of valid formats.

If you set this to Yes because most of your business is within Europe, but you also trade with non-EU countries, you must override the default validation logic so that you can leave the Tax ID–State (VAT Registration) field blank for the non-EU addresses. To do this, set up a blank generalized code for Tax ID–State (`vat_ccode`) in Generalized Codes Maintenance (36.2.13).

Print VAT Registration. This setting specifies whether the system includes VAT registration numbers on printed documents. Set it to Yes to print the relevant VAT registration numbers on documents such as sales quotes, sales orders, invoices, DR/CR memos, purchase orders, blanket orders, shippers, vouchers, service/repair orders, and material orders.

Display Detail on Reports. This setting determines whether you can print a summary of tax amounts on printed documents such as purchase orders, receipts, sales quotes, sales orders, and invoices. You can print tax summaries in document print programs only if both the control file setting and the Print Trailer flag are set to Yes. Tax detail information prints only on documents that have a trailer.

Updating Other MFG/PRO eB Records

Company and Site Addresses

In GTM, company sites require a corresponding company address record because taxes are calculated by address, not site. Every company site must have an address record with the same address code as the site code. Create records in Company Address Maintenance (2.12). Add city, county, state, and country, and tax information to new records.

As a precaution, create a ~taxes record to provide a default tax zone whenever a transaction is missing a company site code.

Customers, Suppliers, and End Users

You can set up default tax data for customers, suppliers, and end users, which is then used on transactions (Figure 11.15).

Note End users are defined in the Service/Support Management module.

Fig. 11.15
Address Tax Data
Window

Update this information in Customer Maintenance (2.1.1), Supplier Maintenance (2.3.1), and End User Address Maintenance (11.9.1).

Taxable. For non-taxable addresses, change this setting to Yes if you report tax exemptions by tax type in GTM.

Tax Zone. The system selects the default tax zone based on the city, county, state or province, and country in the address.

Tax Class. Enter the tax class.

Tax Usage. Enter the tax usage.

Tax In. Set Tax In to Yes if items shipped to or from the address have tax already included in the line item price.

Tax ID–Federal. For reference and documentation purposes, enter a federal tax identification number.

Tax ID–State or VAT Registration. For reference and documentation purposes, enter either a state or provincial tax identification number or a value-added tax registration number.

If you activated VAT registration in Global Tax Management Control File (2.13.24), this field displays the label VAT Registration. The numbers for European Union countries must have one of the formats listed in Table 11.7. These formats are built as follows:

- First two letters are the country code.
- X is letters A-Z or numbers 0-9.
- A is letters A-Z only.
- 9 is 0-9 only.

| Country | VAT Registration Format |
|----------------|-------------------------------|
| Austria | ATXXXXXXXXXX |
| Belgium | BE999999999 |
| Denmark | DK999999999 |
| Finland | FI999999999 |
| France | FR99999999999 |
| Germany | DE999999999 |
| Greece | EL999999999 |
| Ireland | IE9X99999X |
| Italy | IT99999999999 |
| Luxembourg | LU999999999 |
| Netherlands | NL999999999B99 |
| Norway | NO999999999 |
| Portugal | PT999999999 |
| Spain | ESX9999999X |
| Sweden | SE99999999999 |
| United Kingdom | GB999999999 or GB999999999999 |

Table 11.7
VAT Registration
Number Formats

Note For the Netherlands, the tenth character must be the letter B. When you enter an ID in a customer or supplier record, the system checks that it has a valid EU country prefix. If it does, the system verifies that the rest of the number matches the format for that country. If either the prefix or number is invalid, an error displays. The system does not verify that the country prefix matches the country code in the customer or supplier address. For example, the system does not prevent you from entering a French tax ID for a German supplier.

Tax ID–Misc 1, 2, 3. For reference and documentation purposes, enter any other tax identification numbers that are useful.

▶ See *External Interface Guide: Sales and Use Tax.*

Within City. This setting determines whether the address is in the city limits for taxation purposes. It affects only GTM processing that occurs in conjunction with the Sales and Use Tax Interface for U.S. tax processing.

Product Lines and Items

In Product Line Maintenance (1.2.1) and Item Master Maintenance (1.4.1), enter the GTM item tax class in all product line and item records. If necessary, change the taxable status to Yes to accommodate exemption reporting.

▶ See *User Guide Volume 8A: Service/Support Management.*

If you are using the Service/Support Management module, assign tax classes to service categories in Service Category Maintenance (11.21.9).

Implementing Special Taxes

This section provides additional information on how to implement certain kinds of taxes in GTM.

Tax Exemptions

In GTM, tax exemptions are set up by tax type. You can implement separate tax types for each exemption, or group all exemptions into one tax type. Select the approach that supports the level of detail required for governmental reporting.

Reporting by Exemption

- 1 In Tax Type Maintenance (2.13.1.1), set up a separate tax type for each exemption.
- 2 In Tax Environment Maintenance (2.13.5.1), assign the type to each tax environment affected by the exemption.
- 3 In Tax Rate Maintenance (2.13.13.1), set up 0% tax rates for each exemption tax type.
If the exemption is by customer or supplier, set up 0% rates by usage code. If the exemption is by item or trailer charge, set up 0% rates by item tax class.
- 4 In the respective maintenance programs, set the Taxable status of all exempt customers, suppliers, product lines, items, and trailer charges to Yes.
Transactions with a non-taxable status do not calculate tax, but you will be unable to report the reason, since GTM cannot match the exempt amounts to the exemption tax types in the tax environment.

Aggregate Reporting

- 1 In Tax Environment Maintenance (2.13.5.1), assign the default tax type NON-TAX to each tax environment in which exemptions can be reported in aggregate.
You do not have to set up this type; it is supplied by default. Once you do this, GTM automatically classifies all non-taxable transaction amounts as type NON-TAX.
- 2 In the respective maintenance program, set the Taxable status of all exempt customers, suppliers, product lines, items, service categories, and trailer charges to No.
When the system encounters a non-taxable transaction amount, it applies a 0% tax rate to it. This rate is already set up in MFG/PROeB.

Tax Based on Partial Item Amounts

By default, GTM calculates tax for 100% of the item amount. However, tax can be based on a smaller percentage. In these situations, set up a tax base record in Tax Base Maintenance (2.13.1.13), specifying the appropriate Base Percent. Assign this tax base to multiple tax types and tax rates if the Base Percent is the same for all situations.

Custom Tax Calculation Methods

The transaction detail screen displays the following tax-related amounts for line items and trailer charges:

- Total line item or trailer charge amount
- Line item or trailer charge amount not subject to tax
- Line item or trailer charge amount that is subject to tax
- Total tax amount
- Recoverable and nonrecoverable tax amounts
- For sales transactions, any tax your company absorbs rather than passes on to the customer
- For purchase transactions, any tax your company retains for direct payment to the government

To calculate tax amounts, GTM can use one of several standard calculation programs. Alternately, to resolve a localization issue, write a custom program. Specify a default program and override it as necessary for individual tax rates.

Table 11.8 summarizes the differences among the tax calculation methods supplied with MFG/PRO eB.

Table 11.8
Standard GTM Tax
Methods

| Method | Program | Explanation |
|--------|------------|---|
| 01 | txmeth01.p | <p>This generic method supports most taxes.</p> <p>$\text{Tax Amount} = \text{Tax Rate} * \text{Item Amount}$</p> <p>Note: For reverse-calculated taxes, $\text{Tax Amount} = \text{Tax Rate} * [\text{Item Amount} / (1 + \text{Tax Rate})]$</p> <p>$\text{Taxable Base} = \text{Item Amount} * \text{Tax Base Percent}$</p> <p>If Taxable Base < Min. Taxable, Tax Amount = Min. Taxable</p> <p>If Taxable Base > Max. Taxable, Tax Amount = Max. Taxable</p> <p>$\text{Recoverable Amount} = \text{Tax Amount} * \text{Recoverable Percent}$</p> |
| 02 | txmeth02.p | <p>Same as method 01 except that it supports luxury taxes and capped taxes that are assessed only on specific taxable base amounts.</p> <p>If Taxable Base < Min. Taxable, Tax Amount = 0</p> <p>If Taxable Base > Max. Taxable, Tax Amount = 0</p> |
| 03 | txmeth03.p | <p>Indicates you are importing tax amounts from an external system and do not want to recalculate them.</p> |
| 11 | txmeth11.p | <p>Same as method 01 but has a regressive calculation for reverse-calculated taxes.</p> <p>$\text{Tax Amount} = \text{Tax Rate} * \text{Item Amount}$</p> |
| 20 | txmeth20.p | <p>Indicates that Quantum, through the Sales and Use Tax API, calculates taxes for each line item.</p> |

For custom programs, the file naming convention is txmeth##.p, where ## is the numeric identifier referenced in Tax Rate Maintenance. Use an identifier from 50 to 99; identifiers 00 through 49 are reserved for QAD use.

To implement the custom tax method, specify the identifier as the Tax Method in Tax Rate Maintenance (2.13.13.1). If the custom method is the default method for new tax rates, also specify it in the Global Tax Management Control File (2.13.24).

Set up a value in generalized codes for the new method so that it displays in the look-up on the Tax Method field in Tax Rate Maintenance.

Luxury Taxes

Luxury taxes are assessed only on transaction amounts that exceed a specified minimum. For example, a 30% luxury tax may apply only to automobiles costing more than \$30,000.

Two settings in Tax Rate Maintenance (2.13.13.1) govern setup of luxury taxes.

Min. Taxable. This setting identifies the minimum amount subject to tax. In the above example, Min. Taxable is \$30,000.

Tax Method. For luxury taxes, set Tax Method to 02. Whenever the transaction taxable base amount is less than the Min. Taxable amount for the tax rate, the final tax amount is zero.

Capped Taxes

Capped taxes are assessed only on transaction amounts less than a specified maximum. For example, a 10% capped tax applies only to transaction amounts under \$1,000.

Two settings in Tax Rate Maintenance (2.13.13.1) govern setup of capped taxes:

Max. Taxable. This setting identifies the maximum amount subject to tax. In the above example, Max. Taxable is \$1,000.

Tax Method. For capped taxes, set Tax Method to 02. Whenever the transaction taxable base amount exceeds the Max. Taxable amount for the tax rate, the final tax amount is zero.

Recoverable Taxes

Taxes are recoverable whenever your company is eligible to offset a percentage of tax on purchases against tax collected on sales. Recoverable taxes are common in Europe.

The following settings in Tax Rate Maintenance (2.13.13.1) govern setup of recoverable taxes.

Percent Recoverable. The percentage of purchase tax that can be recovered for the tax rate.

AP Tax Account. GL account, sub-account, and cost center for posting recoverable tax amounts. This account is used by Purchase Order Receipts (5.13.1), PO Shipper Receipt (5.13.20), and confirmed accounts payable vouchers (28.1, 28.6, 28.7).

A recoverable tax is an asset when debited for recoverable purchase and accounts payable taxes, or a liability when treated as a contra account to sales tax payable. The default accounts are specified in the System/Account Control File (36.1), but you can override them.

EC Sales List. Set to Yes to include sales and purchases that use these tax rates in the EC Sales Listing (2.13.15.8), a report submitted to the government as verification that recoverable purchase VAT claimed by your company is correct for the amount of VAT it collected on sales.

Accrue Tax at Receipt. Determines when GL entries for purchase tax amounts are created. For recoverable taxes, set this to No because the tax point is receipt of supplier invoice.

Tax-on-Tax

In a tax-on-tax situation, one tax amount is included in the calculation for another tax amount. For example, in some Canadian provinces, Provincial Services Tax (PST) is based on the item amount plus the federal Goods and Services Tax (GST).

To set up a tax-on-tax, define the calculation priority of the two taxes and assign the included tax as the tax base of the other tax.

- 1 In Tax Environment Maintenance (2.13.5.1), assign both tax types to the tax environment. Assign the included tax type a lower sequence number than the other tax type. This ensures that the included tax is calculated first. In the Canadian example, GST has a lower sequence.
- 2 In Tax Base Maintenance (2.13.1.13), define a tax base and assign it to the included tax type. In the Canadian example, GST is the included type.
- 3 In Tax Rate Maintenance (2.13.13.1), set up tax rates for both tax types. In the rate for the tax-on-tax, specify the tax base for the included tax. In the Canadian example, you would set up rates for both GST and PST, then specify the tax base in the PST rates.

Discounted Taxes

In the United Kingdom and some other countries, tax is assessed only on what the customer actually pays—that is, on the sales amount minus credit terms discounts. When taxes are discounted, the net order amount can vary, depending on whether the credit terms discount is applied to the tax amount.

In Tax Rate Maintenance (2.13.13.1), two settings govern the setup of discounted taxes: Discount Tax at Invoice and Discount Tax at Payment.

- For both settings, the order tax amount is the discounted sales amount multiplied by the tax rate.
- For discounting at invoice, the net order amount is the full sales amount plus the discounted tax amount. When payment is received, the system checks that the customer has paid within the discount period. If the customer is still eligible for the discount, the system discounts the sales amount and adds it to the discounted tax amount to recalculate the net order amount.
- In contrast, for discounting at payment, the net order amount is calculated later as the *discounted* sales amount plus the discounted tax amount.
- Under both systems, if the discount period expires, both the accounts receivable and accounts payable payment programs automatically adjust tax amounts upward. The net order amount is recalculated as the full sales amount plus the full tax amount.

Example If the sales amount is 100.00, the credit terms are 2% Net 30, and the tax rate is 10%, the system calculates the discount at invoice as follows:

$$\text{Disc Sales Amt: } 100.00 - (100.00 * 2\%) = 98.00$$

$$\text{Disc Tax Amt: } (98.00 * 10\%) = 9.80$$

$$\text{Net Order Total: } (100.00 + 9.80) = 109.80$$

Initially, only the tax is discounted. If the customer is still eligible for the discount when payment is received, the sales amount is discounted to 98.00 and the payment amount to apply changes to 107.80.

For discounting at payment, the calculation is as follows.

| | |
|-------------------------|-----------------------------------|
| <i>Disc Sales Amt:</i> | $100.00 - (100.00 * 2\%) = 98.00$ |
| <i>Disc Tax Amt:</i> | $(98.00 * 10\%) = 9.80$ |
| <i>Net Order Total:</i> | $(98.00 + 9.80) = 107.80$ |

If the customer is late, the discount tax amount reverts to the non-discounted tax amount of 10.00 and the payment amount to apply changes to 110.00.

Retained Taxes

In some countries, the government declares that large customers of small suppliers are required to remit tax amounts directly to the government instead of to the supplier. Customers of these suppliers pay the purchase amount minus tax to the supplier but are required to calculate, post, and periodically pay the tax amounts on their purchases directly to the government.

Use Tax Rate Maintenance (2.13.13.1) to specify the GL accounts, sub-accounts, and cost centers for AP Retained Tax. To designate a tax rate as a retained tax, set the flag to Yes.

Absorbed Taxes

Absorbed sales tax is a liability you can incur whenever your company is liable for tax but does not charge it to the customer. For example, if you give an item to a customer, you may still pay tax even though the item's sales price is zero. Absorbed sales tax is also called withheld or retained sales tax.

Use Tax Rate Maintenance (2.13.13.1) to specify the GL accounts, sub-accounts, and cost centers for Sales Tax Absorbed. To designate a tax rate as an absorbed tax, set the flag to Yes.

Reverse-Calculated Taxes

Sometimes, item amounts already include tax. For transaction documents and reporting, you must reverse-calculate the tax from the item amount.

The system reverse-calculates tax from the line item price on sales and the item cost on purchases. On sales transactions, it reverse-calculates the taxable base by subtracting the tax amount from the total amount on the line/trailer.

GTM supports two kinds of reverse calculations, as specified by the tax method in the tax rate.

Example For tax method 01, the calculation works as follows:

$$\text{Tax Amount} = \text{Tax Rate} * (\text{Item Price}/1 + \text{Tax Rate})$$

$$0.10 * (100.00/1.10)$$

$$0.10 * 90.90 = 9.09$$

$$\text{Tax Base} = \text{Item Price} - \text{Tax Amount}$$

$$100.00 - 9.09 = 90.91$$

In contrast, for tax method 11 (regressive taxation), the calculation is as follows:

$$\text{Tax Amount} = \text{Item Price} * \text{Tax Rate}$$

$$100.00 * 0.10 = 10.00$$

$$\text{Tax Base} = \text{Item Price} - \text{Tax Amount}$$

$$100.00 - 10.00 = 90.00$$

To set up a reverse-calculated tax, do the following:

- In the address maintenance program, set Tax In to Yes. The tax included status for the customer/supplier ship-to address determines the default tax included status on transactions. The transaction tax included status determines how trailer charges are taxed and becomes the default status for line items in Tax Rate Maintenance (2.13.13.1), set Allow Tax Included to Yes for all tax rates applied to items that already include tax. In addition, specify Tax Method 01 or 11.

Tax is reverse-calculated only for transactions in which the transaction or item Tax In status is Yes and the tax rate Allow Tax Included status is Yes.

Note The ability to reverse-calculate taxes in GTM does not affect sales commission reporting using sales analysis programs. Commissions are always based on item prices inclusive of tax. For items that include tax, you may have to adjust your commission structure.

Processing GTM

This chapter describes how GTM processes tax transactions. It also discusses general ledger transactions created for tax amounts under standard and average costing.

Calculating Taxes **288**

Specifying Tax Data **291**

Viewing Tax Amounts **293**

Correcting Transaction Tax Amounts **295**

General Ledger Effects **296**

Reporting **319**

Fixing Common Tax Problems **320**

| Field | Value | Description |
|--------------------|---------------------|----------------------|
| Routing Code | 10-15000 | MANUFACTURE CHIEFLY |
| Operation | 20 | |
| Standard Operation | 1030 | INSPECTION, ALL SITE |
| Work Center | | |
| Machines | | |
| Description | INSPEC PER PROC-000 | |
| Machines per Op | 1 | |
| Queue Time | 1.0 | |
| Wait Time | 0.0 | |
| Setup Time | 0.0 | |

Calculating Taxes

To calculate taxes on transactions, GTM first identifies the tax environment—the set of tax types for each line item and trailer charge. It then determines the most appropriate tax rate for each tax type in the environment.

GTM searches for an optimal tax environment based on a combination of transaction conditions:

- Ship-from tax zone for the line item
- Ship-to tax zone for the transaction
- Customer or supplier tax class, if any

Figure 12.1 summarizes GTM’s search priority for selecting a tax environment.

Fig. 12.1
Selection of Tax Environment

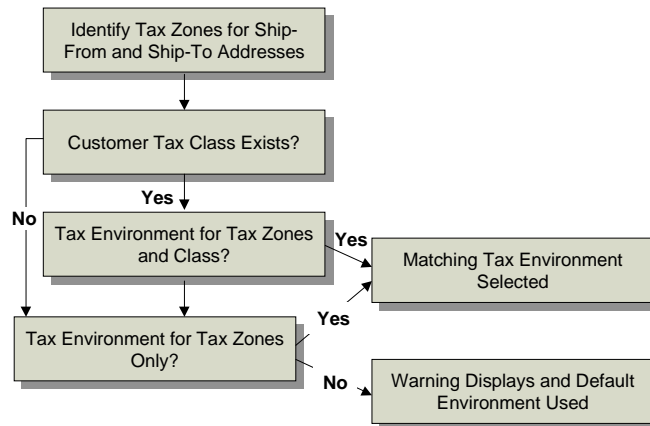

If GTM finds a matching environment, it assigns this environment to the transaction. Otherwise, the following message displays:

Warning: No tax environment found, using default.

▶ See “Fixing Common Tax Problems” on page 320.

The system then uses the error environment from the Global Tax Management Control File (2.13.24). If this happens, investigate and correct the problem.

Table 12.2 describes the tax environment selection criteria for different transaction amounts.

| Item | Ship-To Tax Zone | Ship-From Tax Zone | Tax Class |
|-----------------|------------------------------|--------------------------------|-------------------------------|
| Inventory items | Transaction ship-to tax zone | Line item ship-from tax zone | Transaction tax class, if any |
| Memo items | Transaction ship-to tax zone | Transaction ship-from tax zone | Transaction tax class, if any |
| Trailer charges | Transaction ship-to tax zone | Transaction ship-from tax zone | Transaction tax class, if any |

Table 12.1
Tax Environment Selection Criteria

Next, GTM searches for the tax rate for each tax type in the tax environment. For each tax type, GTM searches for an optimal tax rate based on a combination of transaction and line item conditions:

- Tax class
- Tax usage
- Transaction tax date

Figure 12.2 summarizes the search priority for selecting a tax rate for a tax type. GTM selects a rate only if there is a complete match between the conditions of the transaction and the tax rate. Any nonmatching criteria must be blank. For example, if a tax rate has a matching item tax class and tax date but a different tax usage, it is not selected.

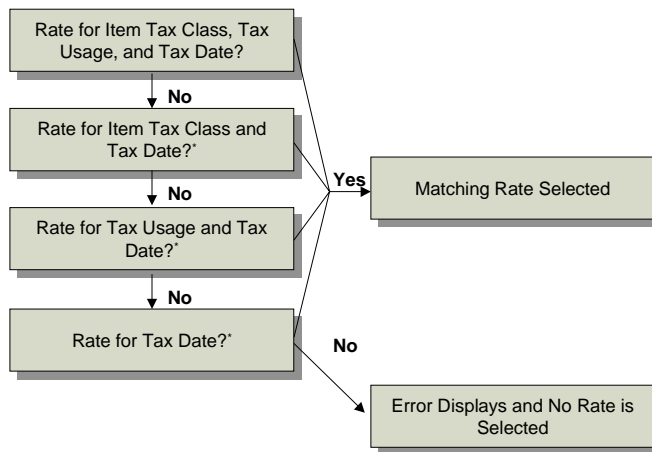

Fig. 12.2
Selection of Tax Rate

* Remaining tax rate fields must be blank.

If GTM finds a matching rate, it uses this rate for the tax calculation. Otherwise, the following message displays:

```
Error: Tax rate does not exist.
      "Tax Type" "Tax Class" "Tax Usage"
```

◆ See “Fixing Common Tax Problems” on page 320.

The message displays the tax type, tax class, and tax usage not found, and no tax is calculated. If this happens, investigate the problem.

Table 12.2 describes the tax rate selection criteria for different transaction amounts.

Table 12.2
Tax Rate Selection
Criteria

| Item | Tax Class | Tax Usage | Tax Date |
|-----------------|---|-------------------------------|----------------------|
| Inventory items | Item tax class, if any | Transaction tax usage, if any | Transaction tax date |
| Memo items | Transaction tax class, if any | Transaction tax usage, if any | Transaction tax date |
| Trailer charges | (1) Tax class from trailer charge detail, if any (2) Trailer charge tax class, if any (3) Transaction tax class, if any | Transaction tax usage, if any | Transaction tax date |

Specifying Tax Data

All transactions subject to tax have tax data windows accessible in the header, line item, and trailer frames. Figure 12.3 illustrates the tax pop-up in the Sales Order Maintenance (7.1.1) header. Most values specified in the header can be modified for each line.

The screenshot shows a window titled "Sales Order Maintenance" with a menu bar (User Menu, Edit, Queue, Options, Help). The main area displays order information: Order: S014404, Sold-To: 010101, Bill-To: 010101, Ship-To: 010101. Below this, there are sections for "Sold-To" and "Ship-To" addresses, both for Morris Electrical Supply at 2343 Manchester Boulevard, Los Angeles, CA 90045, United States of America. A central "Tax" section contains fields for Tax Usage (dropdown), Tax Environment (USA-CA001), Tax Class (RSE), Taxable (yes), and Tax Inc. (no). To the right of these fields are checkboxes for "yes" and "no" next to dates and other settings. At the bottom, there are fields for Order Date (11/24), Required Date (11/25), Promise Date (11/25), Due Date (11/25), Pricing Date (11/24), Purchase Order, Remarks, Entered By (mmb), USD Language (yes RSE), Fixed Price (yes), Credit Terms (yes), Credit Terms Int. (0.00), and Reprice (no).

Fig. 12.3
Sales Order
Maintenance
(7.1.1), Header
Frame

Tax Date. The transaction tax date is used to select tax rates. At order entry, the default tax date is the order due date. At shipment and receipt, the default tax date is the transaction effective date.

In some situations, you should specify another tax date. For example, when processing a return, you can enter the original order date. You cannot override the transaction tax date for individual line items and trailer charges. GTM does not use a tax rate if the transaction's tax date is outside the tax rate's effective date range.

Tax Usage. Tax usage is used to select tax rates. Tax usage defaults from the relevant address record: customer, supplier, or end user. You can override the transaction tax usage for line items but not for trailer charges.

Tax Environment. The tax environment is used to select tax types for the transaction. The ship-from/ship-to tax zones and tax class, if any, determines the default tax environment. A line item can have a different tax environment if its ship-from tax zone is different from the one for the rest of the transaction.

Tax Class. Tax class is used to select the transaction tax environment and/or tax rates for items and trailer charges. Tax class defaults from the relevant address record: customer, supplier, or end user.

For inventory items, the default tax class is the item tax class. For memo items, the default tax class is the transaction tax class. For trailer charges, the tax class is the one for the (1) trailer tax detail, (2) trailer charge, or (3) transaction, depending on which one the system finds first.

Taxable. The taxable status determines how tax types apply to the transaction. If Taxable is No, the amount is nontaxable. However, if Taxable is Yes, the amount can also be nontaxable if you use tax types and zero-percent tax rates to report tax exemptions.

The customer, supplier, or end user taxable status determines the default status of the transaction. If the transaction taxable status is No, the entire order has this status.

For inventory items, the default status is the item status. For memo items, the default status is the transaction taxable status. For trailer charges, the status is the one for the (1) trailer tax detail, (2) trailer charge, or (3) transaction, depending on which one the system finds first.

Tax In. Tax In (tax included) determines whether tax is already included in line item amounts. If it is, the system reverse-calculates the tax from the item amount and displays it along with the other tax amounts.

The customer, supplier, or end user Tax In status determines the default status of the transaction. You can override this status for line items but not trailer charges. For an amount to be tax included, Tax In must be Yes, and the Allow Tax Included setting for the tax rate must be Yes.

Viewing Tax Amounts

In the transaction trailer frame, review system-calculated tax amounts by setting View/Edit Tax Detail to Yes. The screen displays the total nontaxable and taxable line item and trailer charge amounts, the tax date, and tax amounts by category.

Fig. 12.4
Sales Order Maintenance (7.1.1), View/Edit Tax Detail Option

In the tax detail frame, scroll through the Line and Trailer fields to view the tax rate information for each tax type.

Note You cannot change tax amounts unless Update Tax Allowed for the tax rate is Yes.

Fig. 12.5
Sales Order Maintenance (7.1.1), Transaction Tax Detail Frame

Line. Tax amounts for line items and trailer charges are identified by line number. Use the Up/Down arrows to scroll through the amounts for each tax type.

0: Line items taxed by total.

1 through 99998: Line items taxed by line. The line number in the tax detail corresponds to the order line item number.

99999: Trailer charges.

Trailer. For trailer charges, enter the code of the trailer charge subject to the tax.

Tax By. Output only. Total indicates that the tax rate was applied to the order total for all items and trailer charges taxed at this rate. Line indicates that the tax rate was applied separately to each item and trailer charge.

Edited. Output only. This setting indicates whether the tax amount was ever changed from the system-calculated amount.

The system also displays the factors GTM used to calculate the tax: transaction tax date, tax rate, tax code, tax environment, tax type, item or trailer charge tax class, and tax usage.

Depending on how you set up the tax rate, you may be able to change some of the following values. To change values, Update Tax Allowed must be Yes.

Trnx Amt. This value is the total transaction amount, excluding tax.

Nontaxable Base. This is the nontaxable portion of the transaction amount.

Taxable Base. This is the taxable portion of the transaction amount.

Tax Amt. This is the tax amount for the tax type. For line 0, it is the transaction tax amount for the tax type. For lines 1-99999, it is the amount for the line item or trailer charge.

Recoverable Tax. This is the recoverable portion of purchase tax.

Non-Recover Tax. This is the non-recoverable portion of purchase tax.

Absorb/Retain. On sales and accounts receivable transactions, this is the sales tax that was absorbed and therefore not included in the transaction total. On purchasing and accounts payable transactions, it is the purchase tax that was retained for direct payment to the government.

Correcting Transaction Tax Amounts

Depending on how you set up GTM, you can selectively override system-calculated tax amounts. The default behavior is determined first by Update Tax Allowed in the Global Tax Management Control File (2.13.24) then by the same field in individual tax rate records (2.13.13.1).

In transactions, View/Edit Tax Detail always lets you review how the system calculated taxes. If Update Tax Allowed is Yes, you can also change the taxable base, tax, and recoverable tax amounts.

Use this feature to match amounts on manually issued documents. Typically, you edit tax amounts only when transaction tax amounts must exactly match an external document. You can also edit taxes when entering transactions for which you have not set up standard rates. However, the system does not maintain an audit trail of changes, so accounting regulations may prevent you from using this capability.

If you do edit tax amounts, one of the following messages displays when you exit transactions:

Recalculate Tax. Enter Yes to recalculate tax and taxable base amounts based on the current data you entered in the transaction. Do this if you ship or receive a different quantity than originally entered.

Copy Edited Tax Values. Enter Yes to copy previously edited tax amounts to this transaction or No to recalculate taxes based on current transaction information.

For example, when you enter a purchase order, you can manually edit the system-calculated tax amounts. When you process the receipt, copy the edited tax values from the order or recalculate taxes based on the current information. If you did not manually edit the taxes in the order, taxes are automatically recalculated at receipt.

If you enter Yes, the system copies tax amounts from the earlier transaction to the one you are currently working on. If you enter No, the system recalculates taxes. Taxes are copied exactly. The system does not adjust for quantity or price differences between the two transactions.

General Ledger Effects

During transaction processing, the tax point for the tax rate determines when and for which accounts the system creates general ledger (GL) entries for tax amounts. The tax point defaults first from Accrue Tax at Receipt in the Global Tax Management Control File (2.13.24), then from the same setting in individual tax rate records (2.13.13.1).

When the tax point is goods receipt, the system creates GL entries when you record the receiving transaction. When the tax point is invoice receipt, the system creates entries later—when you enter a confirmed voucher or confirm an existing voucher.

For each tax point, exact GL entries vary by cost system. Table 12.3 summarizes the elements that influence GL entries. The subsequent sections for standard costing and average costing illustrate tax accruals in more detail.

Table 12.3
Elements that
Influence GL
Entries for Each
Tax Point

| Costing System at Site, Tax Amount | Taxable Amount | See... |
|------------------------------------|--------------------------|----------|
| Standard, Recoverable | Inventory Items | page 298 |
| | Purchase Price Variances | page 299 |
| | AP Usage Variances | page 300 |
| | AP Rate Variances | page 301 |
| | Memo Items | page 302 |
| | Returned Items | page 302 |
| Standard, Non-Recoverable | Inventory Items | page 303 |
| | Purchase Price Variances | page 304 |
| | AP Usage Variances | page 305 |
| | AP Rate Variances | page 306 |
| | Memo Items | page 307 |
| | Returned Items | page 302 |
| Average, Recoverable | Inventory Items | page 309 |
| | AP Usage Variances | page 310 |
| | AP Rate Variances | page 311 |
| | Memo Items | page 312 |
| | Returned Items | page 312 |
| Average, Non-Recoverable | Inventory Items | page 314 |

| Costing System at Site, Tax Amount | Taxable Amount | See... |
|------------------------------------|--------------------|----------|
| | AP Usage Variances | page 316 |
| | AP Rate Variances | page 317 |
| | Memo Items | page 318 |
| | Returned Items | page 318 |

Standard Cost

This section shows tax accruals for a simple purchase order and voucher, first for recoverable taxes, then for non-recoverable taxes.

▶ To review the entries for average cost, see “Average Cost” on page 308.

Recoverable Tax

Most European countries have a sales tax system that allows recovery of tax on purchases. A recoverable purchase tax amount is one that you are allowed to offset against sales tax payable. Such tax amounts are tracked separately in the GL. For Global Tax Management, they update the AP Tax account for the tax rate. For recoverable taxes, the tax point is normally invoice receipt. However, as a comparison, this section shows the entries for both tax points.

Inventory Items

Figure 12.6 shows the GL entries for purchases of inventory items. The tax point determines whether the update to AP Tax Recoverable occurs at goods receipt or invoice receipt. Inventory items are items you purchase to use in manufacturing or to sell to customers.

Fig. 12.6
GL Entries for
Inventory Item
(Standard Cost/
Recoverable Tax)

GL Entries for Inventory Item (Standard Cost, Recoverable Tax)

Tax Accrual at Goods Receipt

| | | | |
|---|------------|----------------------------|-----------------------|
| Goods Receipt: Entries created for received item cost (1) and tax (2) | Inventory | Purchase Order Receipts | AP Tax Recoverable |
| | 100.00 ① | ① 100.00 ② 10.00 | 10.00 ② |

| | | |
|---|----------------------------|---------------------|
| Voucher Confirmation: Entries created for item cost (3) and tax (4) | Purchase Order Receipts | Accounts Payable |
| | 100.00 ③ 10.00 ④ | ③ 100.00 ④ 10.00 |

Tax Accrual at Invoice Receipt

| | | |
|---|------------|----------------------------|
| Goods Receipt: Entries created for received item cost (1) but not for tax | Inventory | Purchase Order Receipts |
| | 100.00 ① | ① 100.00 |

| | | | |
|---|----------------------------|---------------------|-----------------------|
| Voucher Confirmation: Entries created for item cost (2) and tax (3) | Purchase Order Receipts | Accounts Payable | AP Tax Recoverable |
| | 100.00 ② | ② 100.00 ③ 10.00 | 10.00 ③ |

Variations

Three kinds of variances occur during the purchasing/accounts payable cycle: purchase price variance, AP usage variance, and AP rate variance.

Purchase Price Variance. Purchase price variance occurs when an inventory item's PO cost does not match its GL cost. This variance does not occur for memo items, which have no standard cost.

Figure 12.7 shows the GL entries for purchase price variance. The tax point determines whether the update to AP Tax Recoverable occurs at goods receipt or invoice receipt.

GL Entries for Purchase Price Variance (Standard Cost, Recoverable Tax)

Fig. 12.7
GL Entries for Purchase Price Variance (Standard Cost, Recoverable Tax)

Tax Accrual at Goods Receipt

| | | | |
|--|-------------------------|-------------------------|--|
| Goods Receipt: Entries created for received item cost (1), variance (2), and tax on item cost + variance (3) | Inventory | Purchase Order Receipts | |
| | 100.00 | 100.00 | |
| | 25.00 | 25.00 | |
| | 12.50 | 12.50 | |
| | Purchase Price Variance | AP Tax Recoverable | |
| | 25.00 | 12.50 | |

| | | | |
|--|-------------------------|------------------|--|
| Voucher Confirmation: Entries created for item cost (4), variance (5), and tax (6) | Purchase Order Receipts | Accounts Payable | |
| | 100.00 | 100.00 | |
| | 25.00 | 25.00 | |
| | 12.50 | 12.50 | |

Tax Accrual at Invoice Receipt

| | | | | |
|--|-----------|-------------------------|-------------------------|--|
| Goods Receipt: Entries created for received item cost (1) and variance (2) but not for tax | Inventory | Purchase Order Receipts | Purchase Price Variance | |
| | 100.00 | 100.00 | 25.00 | |
| | | 25.00 | 25.00 | |

| | | | | |
|--|-------------------------|------------------|--------------------|--|
| Voucher Confirmation: Entries created for item cost (3), variance (4), and tax on item cost + variance (5) | Purchase Order Receipts | Accounts Payable | AP Tax Recoverable | |
| | 100.00 | 100.00 | 12.50 | |
| | 25.00 | 25.00 | 12.50 | |

AP Rate and Usage Variance. AP rate variance occurs when an item’s invoice cost does not match its PO cost. AP usage variance occurs when an item’s invoice quantity does not match its PO quantity and you close the receiver line in the voucher.

Figure 12.8 and Figure 12.9 show GL entries for inventory items. Entries for memo items update Expensed Item Receipts instead of Purchase Order Receipts, and Expensed Purchases instead of Inventory. In addition, for memo items, an option in the Accounts Payable Control File (28.24) allows variances to update Expensed Item Receipts instead of the variance accounts.

Fig. 12.8
GL Entries for AP Usage Variance (Standard Cost, Recoverable Tax)

GL Entries for AP Usage Variance
(Standard Cost, Recoverable Tax)

Tax Accrual at Goods Receipt

| | | | |
|--|-------------------------|------------------------------|--------------------|
| Goods Receipt: Entries created for received item cost (1) and tax (2) | Inventory | Purchase Order Receipts | AP Tax Recoverable |
| | 100.00 ① | ① 100.00 ② 10.00 | 10.00 ② |
| Voucher Confirmation: Entries created for item cost (3), variance (4), tax on item cost (5), and tax on variance (6) | Purchase Order Receipts | Accounts Payable | |
| | 100.00 ③ | ③ 100.00 | |
| | 10.00 ⑤ | ④ 40.00 ⑤ 10.00 ⑥ 4.00 | |
| | AP Usage Variance | AP Tax Recoverable | |
| | 40.00 ④ | 4.00 ⑥ | |

Tax Accrual at Invoice Receipt

| | | | |
|--|-------------------------|--|--|
| Goods Receipt: Entries created for received item cost (1) but not tax | Inventory | Purchase Order Receipts | |
| | 100.00 ① | ① 100.00 | |
| Voucher Confirmation: Entries created for item cost (2), variance (3), tax on item cost (4), and tax on variance (5) | Purchase Order Receipts | Accounts Payable | |
| | 100.00 ② | ② 100.00 ③ 40.00 ④ 10.00 ⑤ 4.00 | |
| | AP Usage Variance | AP Tax Recoverable | |
| | 40.00 ③ | 10.00 ④ 4.00 ⑤ | |

GL Entries for AP Rate Variance
(Standard Cost, Recoverable Tax)

Fig. 12.9
GL Entries for AP Rate Variance
(Standard Cost, Recoverable Tax)

Tax Accrual at Goods Receipt

| | | | |
|---|------------|----------------------------|-----------------------|
| Goods Receipt: Entries created for received item cost (1) and tax (2) | Inventory | Purchase Order Receipts | AP Tax Recoverable |
| | 100.00 ① | ① 100.00 ② 10.00 | 10.00 ② |

| | | |
|--|----------------------------|--|
| Voucher Confirmation: Entries created for item cost (3), variance (4), tax on item cost (5), and tax on variance (6) | Purchase Order Receipts | Accounts Payable |
| | 100.00 ③ 10.00 ④ | ③ 100.00 ④ 30.00 ⑤ 10.00 ⑥ 3.00 |

| | |
|---------------------|-----------------------|
| AP Rate Variance | AP Tax Recoverable |
| 30.00 ⑤ | 3.00 ⑥ |

Tax Accrual at Invoice Receipt

| | | |
|---|------------|----------------------------|
| Goods Receipt: Entries created for received item cost (1) but not tax | Inventory | Purchase Order Receipts |
| | 100.00 ① | ① 100.00 |

| | | |
|--|----------------------------|--|
| Voucher Confirmation: Entries created for item cost (2), variance (3), tax on item cost (4), and tax on variance (5) | Purchase Order Receipts | Accounts Payable |
| | 100.00 ② | ② 100.00 ③ 30.00 ④ 10.00 ⑤ 3.00 |

| | |
|---------------------|-----------------------|
| AP Rate Variance | AP Tax Recoverable |
| 30.00 ③ | 10.00 ④ 3.00 ⑤ |

Memo Items

Memo items are non-inventory items such as office supplies. By definition, such items have no standard cost. Figure 12.10 shows GL entries for memo items. The tax point determines whether the update to AP Tax Recoverable occurs at goods receipt or invoice receipt.

Fig. 12.10
GL Entries for
Memo Item
(Standard Cost,
Recoverable Tax)

GL Entries for Memo Item (Recoverable Tax)

Tax Accrual at Goods Receipt

| | | | |
|---|-----------------------|---------------------------|-----------------------|
| Goods Receipt: Entries created for received item cost (1) and tax (2) | Expensed Purchases | Expensed Item Receipts | AP Tax Recoverable |
| | 100.00 ① | ① 100.00 ② 10.00 | 10.00 ② |

| | | |
|---|---------------------------|-------------------------|
| Voucher Confirmation: Entries created for item cost (3) and tax (4) | Expensed Item Receipts | Accounts Payable |
| | 100.00 ③ 10.00 ④ | ③ 100.00 ④ 10.00 |

Tax Accrual at Invoice Receipt

| | | |
|---|-----------------------|---------------------------|
| Goods Receipt: Entries created for received item cost (1) but not for tax | Expensed Purchases | Expensed Item Receipts |
| | 100.00 ① | ① 100.00 |

| | | | |
|---|---------------------------|-------------------------|-----------------------|
| Voucher Confirmation: Entries created for item cost (2) and tax (3) | Expensed Item Receipts | Accounts Payable | AP Tax Recoverable |
| | 100.00 ② | ② 100.00 ③ 10.00 | 10.00 ③ |

Returned Items

When you return items, the system clears the item cost and the tax from the accounts updated by the original receipt and the voucher, if you processed the return after paying the supplier invoice.

Non-Recoverable Tax

You cannot offset a non-recoverable purchase tax amount against sales tax payable. Usually, such taxes are already included in the item cost. Purchasing transactions back-calculate the tax from the item amount, assuming you set up the supplier and tax rate records to support this. The following section illustrates the GL entries if taxes were not included.

Inventory Items

Figure 12.11 shows the GL entries for purchases of inventory items. The tax point determines whether the update to AP Tax Recoverable occurs at goods receipt or invoice receipt. Inventory items are items you purchase to use in manufacturing or to sell to customers.

GL Entries for Inventory Item (Standard Cost, Non-Recoverable Tax)

Tax Accrual at Goods Receipt

| | | | |
|---|------------|-------------------------|-------------------------|
| Goods Receipt: Entries created for received item cost (1) and tax (2) | Inventory | Purchase Order Receipts | Purchase Price Variance |
| | 100.00 ① | ① 100.00 ② 10.00 | 10.00 ② |

| | | |
|---|-------------------------|-------------------------|
| Voucher Confirmation: Entries created for item cost (3) and tax (4) | Purchase Order Receipts | Accounts Payable |
| | 100.00 ③ 10.00 ④ | ③ 100.00 ④ 10.00 |

Tax Accrual at Invoice Receipt

| | | |
|---|------------|-------------------------|
| Goods Receipt: Entries created for received item cost (1) but not for tax | Inventory | Purchase Order Receipts |
| | 100.00 ① | ① 100.00 |

| | | | |
|---|-------------------------|-------------------------|-----------|
| Voucher Confirmation: Entries created for item cost (2) and tax (3) | Purchase Order Receipts | Accounts Payable | Inventory |
| | 100.00 ② | ② 100.00 ③ 10.00 | 10.00 ③ |

Fig. 12.11
GL Entries for Inventory Item (Standard Cost, Non-Recoverable Tax)

Variations

Three kinds of variations occur during the purchasing/accounts payable cycle: purchase price variance, AP usage variance, and AP rate variance.

Purchase Price Variations. Purchase price variance occurs when an inventory item’s PO cost does not match its GL cost. This variance does not occur for memo items, which have no standard cost. Figure 12.12 shows the GL entries for purchase price variance. The tax point determines whether the update to AP Tax Recoverable occurs at goods receipt or invoice receipt.

Fig. 12.12
GL Entries for Purchase Price Variance (Standard Cost, Non-Recoverable Tax)

GL Entries for Purchase Price Variance (Standard Cost, Non-Recoverable Tax)

Tax Accrual at Goods Receipt

| | | | | | | | | | |
|--|-----------|--------|---|-------------------------|--------|-------|-------------------------|--------|---|
| Goods Receipt: Entries created for received item cost (1), variance (2), and tax on item cost + variance (3) | Inventory | 100.00 | ① | Purchase Order Receipts | 100.00 | ① | Purchase Price Variance | 25.00 | ② |
| | | | | 25.00 | ② | 12.50 | ③ | | |
| | | | | 12.50 | ③ | | | | |
| | | | | | | | | | |
| Voucher Confirmation: Entries created for item cost (4), variance (5), and tax (6) | | | | Purchase Order Receipts | 100.00 | ④ | Accounts Payable | 100.00 | ④ |
| | | | | 25.00 | ⑤ | 12.50 | ⑥ | 25.00 | ⑤ |
| | | | | 12.50 | ⑥ | | | 12.50 | ⑥ |
| | | | | | | | | | |

Tax Accrual at Invoice Receipt

| | | | | | | | | | |
|--|-----------|--------|---|-------------------------|--------|-------|-------------------------|--------|---|
| Goods Receipt: Entries created for received item cost (1) and variance (2) but not for tax | Inventory | 100.00 | ① | Purchase Order Receipts | 100.00 | ① | Purchase Price Variance | 25.00 | ② |
| | | | | 25.00 | ② | | | | |
| | | | | | | | | | |
| Voucher Confirmation: Entries created for item cost (3), variance (4), and tax on item cost + variance (5) | | | | Purchase Order Receipts | 100.00 | ③ | Accounts Payable | 100.00 | ③ |
| | | | | 25.00 | ④ | 12.50 | ④ | 25.00 | ④ |
| | | | | | | | AP Tax Recoverable | 12.50 | ⑤ |
| | | | | | | | | | |

AP Rate and Usage Variances. AP rate variance occurs when an item's invoice cost does not match its PO cost. AP usage variance occurs when an item's invoice quantity does not match its PO quantity and you close the receiver line in the voucher.

Figure 12.13 and Figure 12.14 show GL entries for inventory items. Entries for memo items update Expensed Item Receipts instead of Purchase Order Receipts, and Expensed Purchases instead of Inventory. In addition, for memo items, an option in the Accounts Payable Control File (28.24) allows variances to update Expensed Item Receipts instead of the variance accounts.

GL Entries for AP Usage Variance (Standard Cost, Non-Recoverable Tax)

Fig. 12.13
GL Entries for AP Usage Variance (Standard Cost, Non-Recoverable Tax)

Tax Accrual at Goods Receipt

| | | | |
|--|-------------------------|-------------------------|-------------------------|
| Goods Receipt: Entries created for received item cost (1) and tax (2) | Inventory | Purchase Order Receipts | Purchase Price Variance |
| | 100.00 ① | ① 100.00 ② 10.00 | 10.00 ② |
| Voucher Confirmation: Entries created for item cost (3), variance (4), tax on item cost (5), and tax on variance (6) | Purchase Order Receipts | Accounts Payable | AP Usage Variance |
| | 100.00 ③ | ③ 100.00 | 40.00 ④ |
| | 10.00 ⑤ | ④ 40.00 | 4.00 ⑥ |
| | | ⑤ 10.00 | |
| | | ⑥ 4.00 | |
| | | | |

Tax Accrual at Invoice Receipt

| | | |
|--|-------------------------|-------------------------|
| Goods Receipt: Entries created for received item cost (1) but not tax | Inventory | Purchase Order Receipts |
| | 100.00 ① | ① 100.00 |
| Voucher Confirmation: Entries created for item cost (2), variance (3), tax on item cost (4), and tax on variance (5) | Purchase Order Receipts | Accounts Payable |
| | 100.00 ② | ② 100.00 |
| | | ③ 40.00 |
| | | ④ 10.00 |
| | | ⑤ 4.00 |
| AP Usage Variance | Inventory | |
| 40.00 ③ | 10.00 ④ | |
| 4.00 ⑤ | | |

Fig. 12.14
 GL Entries for AP
 Rate Variance
 (Standard Cost,
 Non-Recoverable
 Tax)

GL Entries for AP Rate Variance
 (Standard Cost, Non-Recoverable Tax)

Tax Accrual at Goods Receipt

| | | | |
|--|----------------------------|----------------------------|----------------------------|
| Goods Receipt: Entries created for received item cost (1) and tax (2) | Inventory | Purchase Order Receipts | Purchase Price Variance |
| | 100.00 ① | ① 100.00 ② 10.00 | 10.00 ② |
| Voucher Confirmation: Entries created for item cost (3), variance (4), tax on item cost (5), and tax on variance (6) | Purchase Order Receipts | Accounts Payable | AP Rate Variance |
| | 100.00 ③ | ③ 100.00 | 30.00 ④ |
| | 10.00 ⑤ | ④ 30.00 ⑤ 10.00 | 3.00 ⑥ |
| | | ⑥ 3.00 | |

Tax Accrual at Invoice Receipt

| | | |
|--|----------------------------|--|
| Goods Receipt: Entries created for received item cost (1) but not tax | Inventory | Purchase Order Receipts |
| | 100.00 ① | ① 100.00 |
| Voucher Confirmation: Entries created for item cost (2), variance (3), tax on item cost (4), and tax on item cost + variance (5) | Purchase Order Receipts | Accounts Payable |
| | 100.00 ② | ② 100.00 ③ 30.00 ④ 10.00 ⑤ 3.00 |
| | AP Rate Variance | Inventory |
| | 30.00 ③ 3.00 ⑤ | 10.00 ④ |

Memo Items

Memo items are non-inventory items such as office supplies. By definition, such items have no standard cost. Figure 12.15 shows GL entries for memo items. The tax point determines whether the update to AP Tax Recoverable occurs at goods receipt or invoice receipt.

GL Entries for Memo Item (Non-Recoverable Tax)

Fig. 12.15
GL Entries for
Memo Item
(Standard Cost,
Non-Recoverable
Tax)

Tax Accrual at Goods Receipt

| | | | | |
|---|--------------------|---|------------------------|--------|
| Goods Receipt: Entries created for received item cost (1) and tax (2) | Expensed Purchases | | Expensed Item Receipts | |
| | 100.00 | ① | ① | 100.00 |
| | 10.00 | ② | ② | 10.00 |

| | | | | |
|---|------------------------|---|------------------|--------|
| Voucher Confirmation: Entries created for item cost (3) and tax (4) | Expensed Item Receipts | | Accounts Payable | |
| | 100.00 | ③ | ③ | 100.00 |
| | 10.00 | ④ | ④ | 10.00 |

Tax Accrual at Invoice Receipt

| | | | | |
|---|--------------------|---|------------------------|--------|
| Goods Receipt: Entries created for received item cost (1) but not for tax | Expensed Purchases | | Expensed Item Receipts | |
| | 100.00 | ① | ① | 100.00 |

| | | | | | | |
|---|------------------------|---|------------------|--------|--------------------|---|
| Voucher Confirmation: Entries created for item cost (2) and tax (3) | Expensed Item Receipts | | Accounts Payable | | Expensed Purchases | |
| | 100.00 | ② | ② | 100.00 | 10.00 | ③ |
| | | | ③ | 10.00 | | |

Returned Items

When you return items, the system clears the item cost and the tax from the accounts updated by the original receipt and the voucher, if you processed the return after paying the supplier invoice.

Average Cost

▶ To review the entries for standard cost, see “Standard Cost” on page 297.

This section shows tax accruals for a simple purchase order and voucher, first for recoverable taxes, then for non-recoverable taxes.

For average costing, the system re-averages item costs at both receipt and voucher confirmation. If the tax point is goods receipt, the cost basis for re-averaging calculations includes tax at both receipt and voucher confirmation. However, if the tax point is invoice receipt, the cost basis includes tax only at voucher confirmation.

Recoverable Tax

Most European countries have a sales tax system that allows recovery of tax on purchases. A recoverable purchase tax amount is one that you are allowed to offset against sales tax payable. Such tax amounts are tracked separately in the GL. For Global Tax Management, they update the AP Tax account for the tax rate. For recoverable taxes, the tax point is normally invoice receipt. However, as a comparison, the following examples show the entries for both tax points.

Inventory Items

Figure 12.16 shows the GL entries for purchases of inventory items. The tax point determines whether the update to AP Tax Recoverable occurs at goods receipt or invoice receipt. Inventory items are items you purchase to use in manufacturing or to sell to customers.

GL Entries for Inventory Item (Average Cost, Recoverable Tax)

Tax Accrual at Goods Receipt

| | | | |
|---|------------|----------------------------|-----------------------|
| Goods Receipt: Entries created for received item cost (1) and tax (2) | Inventory | Purchase Order Receipts | AP Tax Recoverable |
| | 100.00 ① | ① 100.00 ② 10.00 | 10.00 ② |

| | | |
|---|----------------------------|---------------------|
| Voucher Confirmation: Entries created for item cost (3) and tax (4) | Purchase Order Receipts | Accounts Payable |
| | 100.00 ③ 10.00 ④ | ③ 100.00 ④ 10.00 |

Tax Accrual at Invoice Receipt

| | | |
|---|------------|----------------------------|
| Goods Receipt: Entries created for received item cost (1) but not for tax | Inventory | Purchase Order Receipts |
| | 100.00 ① | ① 100.00 |

| | | | |
|---|----------------------------|---------------------|-----------------------|
| Voucher Confirmation: Entries created for item cost (2) and tax (3) | Purchase Order Receipts | Accounts Payable | AP Tax Recoverable |
| | 100.00 ② | ② 100.00 ③ 10.00 | 10.00 ③ |

Fig. 12.16
GL Entries for
Inventory Item
(Average Cost,
Recoverable Tax)

Variations

Two kinds of variations occur during the purchasing/accounts payable cycle: AP usage variance and AP rate variance.

AP Rate and Usage Variations. AP rate variance occurs when an item's invoice cost does not match its PO cost. AP usage variance

occurs when an item’s invoice quantity does not match its PO quantity and you close the receiver line in the voucher.

Figure 12.17 and Figure 12.18 show GL entries for inventory items. Entries for memo items update Expensed Item Receipts instead of Purchase Order Receipts, and Expensed Purchases instead of Inventory. In addition, for memo items, an option in the Accounts Payable Control File (28.24) allows variances to update Expensed Item Receipts instead of the variance accounts.

Fig. 12.17
GL Entries for AP Usage Variance (Average Cost, Recoverable Tax)

GL Entries for AP Usage Variance
(Average Cost, Recoverable Tax)

Tax Accrual at Goods Receipt

| | | | |
|--|------------|-------------------------|------------------------------|
| Goods Receipt: Entries created for received item cost (1) and tax (2) | Inventory | Purchase Order Receipts | AP Tax Recoverable |
| | 100.00 ① | ① 100.00 ② 10.00 | 10.00 ② |
| Voucher Confirmation: Entries created for item cost (3), variance (4), tax on item cost (5), and tax on variance (6) | | Purchase Order Receipts | Accounts Payable |
| | | 100.00 ③ | ③ 100.00 |
| | | 10.00 ⑤ | ④ 40.00 ⑤ 10.00 ⑥ 4.00 |
| | | AP Usage Variance | AP Tax Recoverable |
| | 40.00 ④ | 4.00 ⑥ | |

Tax Accrual at Invoice Receipt

| | | | |
|--|------------|-------------------------|--|
| Goods Receipt: Entries created for received item cost (1) but not tax | Inventory | Purchase Order Receipts | |
| | 100.00 ① | ① 100.00 | |
| Voucher Confirmation: Entries created for item cost (2), variance (3), tax on item cost (4), and tax on variance (5) | | Purchase Order Receipts | Accounts Payable |
| | | 100.00 ② | ② 100.00 ③ 40.00 ④ 10.00 ⑤ 4.00 |
| | | AP Usage Variance | AP Tax Recoverable |
| | | 40.00 ③ | 10.00 ④ 4.00 ⑤ |

GL Entries for AP Rate Variance
(Average Cost, Recoverable Tax)

Fig. 12.18
GL Entries for AP Rate Variance (Average Cost, Recoverable Tax)

Tax Accrual at Goods Receipt

| | | | |
|--|------------------|-------------------------|--------------------|
| Goods Receipt: Entries created for received item cost (1) and tax (2) | Inventory | Purchase Order Receipts | AP Tax Recoverable |
| | 100.00 ① | ① 100.00 ② 10.00 | 10.00 ② |
| Voucher Confirmation: Entries created for item cost (3), variance (4), tax on item cost (5), and tax on variance (6) | | Purchase Order Receipts | Accounts Payable |
| | | 100.00 ③ | ③ 100.00 |
| | | 10.00 ④ | ④ 30.00 |
| | | | ⑤ 10.00 |
| | | | ⑥ 3.00 |
| | AP Rate Variance | AP Tax Recoverable | |
| | 30.00 ⑤ | 3.00 ⑥ | |

Tax Accrual at Invoice Receipt

| | | |
|--|------------------|-------------------------|
| Goods Receipt: Entries created for received item cost (1) but not tax | Inventory | Purchase Order Receipts |
| | 100.00 ① | ① 100.00 |
| Voucher Confirmation: Entries created for item cost (2), variance (3), tax on item cost (4), and tax on variance (5) | | Purchase Order Receipts |
| | | 100.00 ② |
| | | ② 100.00 |
| | | ③ 30.00 |
| | | ④ 10.00 |
| | ⑤ 3.00 | |
| | AP Rate Variance | AP Tax Recoverable |
| | 30.00 ③ | 10.00 ④ 3.00 ⑤ |

Memo Items

Memo items are non-inventory items such as office supplies. Figure 12.19 shows GL entries for memo items. The tax point determines whether the update to AP Tax Recoverable occurs at goods receipt or invoice receipt.

Fig. 12.19
GL Entries for
Memo Item
(Average Cost,
Recoverable Tax)

GL Entries for Memo Item (Recoverable Tax)

Tax Accrual at Goods Receipt

| | | | |
|---|---------------------------|---------------------------|-----------------------|
| Goods Receipt: Entries created for received item cost (1) and tax (2) | Expensed Purchases | Expensed Item Receipts | AP Tax Recoverable |
| | 100.00 ① | ① 100.00 ② 10.00 | 10.00 ② |
| Voucher Confirmation: Entries created for item cost (3) and tax (4) | Expensed Item Receipts | Accounts Payable | |
| | 100.00 ③ 10.00 ④ | ③ 100.00 ④ 10.00 | |

Tax Accrual at Invoice Receipt

| | | | |
|---|---------------------------|---------------------------|-----------------------|
| Goods Receipt: Entries created for received item cost (1) but not for tax | Expensed Purchases | Expensed Item Receipts | |
| | 100.00 ① | ① 100.00 | |
| Voucher Confirmation: Entries created for item cost (2) and tax (3) | Expensed Item Receipts | Accounts Payable | AP Tax Recoverable |
| | 100.00 ② | ② 100.00 ③ 10.00 | 10.00 ③ |

Returned Items

When you return items, the system clears the item cost and the tax from the accounts updated by the original receipt and the voucher, if you processed the return after paying the supplier invoice.

Non-Recoverable Tax

You cannot offset a non-recoverable purchase tax amount against sales tax payable. Usually, such taxes are already included in the item cost. Purchasing transactions then back-calculate the tax from the item amount, assuming you set up the supplier and tax rate records to support this. The following section illustrates the GL entries if taxes were not included.

Inventory Items

Figure 12.20 shows the GL entries for purchases of inventory items. The tax point determines whether the update to AP Tax Recoverable occurs at goods receipt or invoice receipt. Inventory items are items you purchase to use in manufacturing or to sell to customers.

Fig. 12.20
 GL Entries for
 Inventory Item
 (Average Cost,
 Non-Recoverable
 Tax)

GL Entries for Inventory Item
 (Average Cost, Non-Recoverable Tax)

Tax Accrual at Goods Receipt

| | | | |
|---|-----------|----------------------------|-----------|
| Goods Receipt: Entries created for received item cost (1) and tax (2) | Inventory | Purchase Order Receipts | Inventory |
| | 100.00 | 100.00 | 10.00 |
| | ① | ① ② | ② |

| | | |
|---|----------------------------|---------------------|
| Voucher Confirmation: Entries created for item cost (3) and tax (4) | Purchase Order Receipts | Accounts Payable |
| | 100.00 | 100.00 |
| | ③ | ③ ④ |

Tax Accrual at Invoice Receipt

| | | |
|---|-----------|----------------------------|
| Goods Receipt: Entries created for received item cost (1) but not for tax | Inventory | Purchase Order Receipts |
| | 100.00 | 100.00 |
| | ① | ① |

| | | | |
|---|----------------------------|---------------------|-----------|
| Voucher Confirmation: Entries created for item cost (2) and tax (3) | Purchase Order Receipts | Accounts Payable | Inventory |
| | 100.00 | 100.00 | 10.00 |
| | ② | ② ③ | ③ |

Variations

Two kinds of variations occur during the purchasing/accounts payable cycle: AP usage variance and AP rate variance.

AP Rate and Usage Variations. AP rate variance occurs when an item's invoice cost does not match its PO cost. AP usage variance occurs when an item's invoice quantity does not match its PO quantity and you close the receiver line in the voucher.

Figure 12.21 and Figure 12.22 show GL entries for inventory items. Entries for memo items update Expensed Item Receipts instead of Purchase Order Receipts, and Expensed Purchases instead of Inventory. In addition, for memo items, an option in the Accounts Payable Control File (28.24) allows variations to update Expensed Item Receipts instead of the variance accounts.

Fig. 12.21
 GL Entries for AP Usage Variance
 (Average Cost, Non-Recoverable Tax)

GL Entries for AP Usage Variance
 (Average Cost, Non-Recoverable Tax)

Tax Accrual at Goods Receipt

Goods Receipt:
 Entries created for received item cost (1) and tax (2)

| Inventory | | Purchase Order Receipts | |
|-----------|---|-------------------------|--------|
| 100.00 | ① | ① | 100.00 |
| 10.00 | ② | ② | 10.00 |

Voucher Confirmation:
 Entries created for item cost (3), variance (4), tax on item cost (5), and tax on variance (6)

| Purchase Order Receipts | Accounts Payable | AP Usage Variance | |
|-------------------------|------------------|-------------------|---------|
| 100.00 ③ | ③ | 100.00 | 40.00 ④ |
| 10.00 ⑤ | ④ | 40.00 | 4.00 ⑥ |
| | ⑤ | 10.00 | |
| | ⑥ | 4.00 | |

Tax Accrual at Invoice Receipt

Goods Receipt:
 Entries created for received item cost (1) but not tax

| Inventory | Purchase Order Receipts |
|-----------|-------------------------|
| 100.00 ① | ① 100.00 |

Voucher Confirmation:
 Entries created for item cost (2), variance (3), tax on item cost (4), and tax on variance (5)

| Purchase Order Receipts | Accounts Payable |
|-------------------------|------------------|
| 100.00 ② | ② 100.00 |
| | ③ 40.00 |
| | ④ 10.00 |
| | ⑤ 4.00 |

| AP Usage Variance | Inventory |
|-------------------|-----------|
| 40.00 ③ | 10.00 ④ |
| 4.00 ⑤ | |

GL Entries for AP Rate Variance
(Average Cost, Non-Recoverable Tax)

Fig. 12.22
GL Entries for AP Rate Variance (Average Cost, Non-Recoverable Tax)

Tax Accrual at Goods Receipt

| | | | | |
|---|-----------|---|----------------------------|--------|
| Goods Receipt: Entries created for received item cost (1) and tax (2) | Inventory | | Purchase Order Receipts | |
| | 100.00 | ① | ① | 100.00 |
| | 10.00 | ② | ② | 10.00 |

| | | | |
|--|----------------------------|---------------------|---------------------|
| Voucher Confirmation: Entries created for item cost (3), variance (4), tax on item cost (5), and tax on variance (6) | Purchase Order Receipts | Accounts Payable | AP Rate Variance |
| | 100.00 | ③ | ③ |
| | 10.00 | ⑤ | ④ |
| | | ④ | 100.00 |
| | | ⑤ | 30.00 |
| | | ⑥ | 10.00 |
| | | ⑥ | 3.00 |

Tax Accrual at Invoice Receipt

| | | | | |
|---|-----------|---|----------------------------|--------|
| Goods Receipt: Entries created for received item cost (1) but not tax | Inventory | | Purchase Order Receipts | |
| | 100.00 | ① | ① | 100.00 |

| | | | |
|--|----------------------------|---------------------|--------|
| Voucher Confirmation: Entries created for item cost (2), variance (3), tax on item cost (4), and tax on item cost + variance (5) | Purchase Order Receipts | Accounts Payable | |
| | 100.00 | ② | ② |
| | | ③ | 100.00 |
| | | ④ | 30.00 |
| | | ⑤ | 10.00 |

| | | | |
|---------------------|---|-----------|-------|
| AP Rate Variance | | Inventory | |
| 30.00 | ③ | ④ | 10.00 |
| 3.00 | ⑤ | | |

Memo Items

Memo items are non-inventory items such as office supplies. Figure 12.23 shows GL entries for memo items. The tax point determines whether the update to AP Tax Recoverable occurs at goods receipt or invoice receipt.

Fig. 12.23
GL Entries for
Memo Item
(Average Cost,
Non-Recoverable
Tax)

GL Entries for Memo Item (Non-Recoverable Tax)

Tax Accrual at Goods Receipt

| | | |
|---|-----------------------|---------------------------|
| Goods Receipt: Entries created for received item cost (1) and tax (2) | Expensed Purchases | Expensed Item Receipts |
| | 100.00 ① | ① 100.00 |
| | 10.00 ② | ② 10.00 |

| | | |
|---|---------------------------|---------------------|
| Voucher Confirmation: Entries created for item cost (3) and tax (4) | Expensed Item Receipts | Accounts Payable |
| | 100.00 ③ | ③ 100.00 |
| | 10.00 ④ | ④ 10.00 |

Tax Accrual at Invoice Receipt

| | | |
|---|-----------------------|---------------------------|
| Goods Receipt: Entries created for received item cost (1) but not for tax | Expensed Purchases | Expensed Item Receipts |
| | 100.00 ① | ① 100.00 |

| | | | |
|---|---------------------------|---------------------|-----------------------|
| Voucher Confirmation: Entries created for item cost (2) and tax (3) | Expensed Item Receipts | Accounts Payable | Expensed Purchases |
| | 100.00 ② | ② 100.00 | 10.00 ③ |
| | | ③ 10.00 | |

Returned Items

When you return items, the system clears the item cost and the tax from the accounts updated by the original receipt and the voucher, if you processed the return after paying the supplier invoice.

Reporting

Printing Tax Information on Documents

To print tax detail information on documents such as sales orders, two fields must be Yes:

- Print Tax Detail on Reports in the Global Tax Management Control File (2.13.24)
- Print Trailer in the document print program

Tax Reports

Tax reports are located in the Tax History Menu (2.13.15):

- Tax Detail by Transaction Inquiry (2.13.15.2)
- Tax Detail by Transaction Report (2.13.15.3)
- EC Sales Listing (2.13.15.8)
- VAT Registration Number Report (2.13.15.9)
- AR Tax by Transaction Report (2.13.15.13)
- AR Tax by Tax Rate Report (2.13.15.14)
- AP Tax by Transaction Report (2.13.15.16)
- AP Tax by Tax Rate Report (2.13.15.17)

Note These reports do not necessarily satisfy local tax laws. You often must write custom reports.

Fixing Common Tax Problems

Table 12.4 describes common tax processing problems and possible causes.

Table 12.4
Common Tax
Processing
Problems

| Problem | Possible Cause |
|---|--|
| Warning: No tax environment found, using default. | GTM could not find a tax environment for the ship-from/ship-to tax zone combination, so it inserted the error code from the Global Tax Management Control File (2.13.24). GTM can also select the wrong environment if the tax zone was wrong in the address records for your company, the customer, or the supplier. |
| Error: Tax rate does not exist. | a) No tax rate exists for the tax type, item or trailer charge tax class, item or transaction tax usage, and/or transaction tax date. b) If the system finds a tax class or tax usage specific rate for an item or trailer charge, it expects to find one for all applicable tax types. |
| The transaction has the right tax environment but the wrong tax type. | The tax environment has the wrong tax type. |
| Tax was calculated incorrectly. | Field settings in your transaction must be consistent with corresponding settings for the tax rate. For example, for tax to be reverse-calculated, Tax In must be Yes in both the transaction line item frame and the tax rate record. Occasionally, the system calculates tax correctly but they do not match the value on a printed document. |

Index

Symbols

~reports 173
~screens 173
~taxes 174

Numerics

1.1.1 33
1.1.13 31
1.1.18 30, 31, 32
1.2.1 25
1.2.13 25
1.2.17 26
1.4.1 14
1.4.3 90, 113
1.4.5 14, 18
1.4.7 14
1.4.9 14
1.4.16 14
1.4.17 14
1.4.18 14, 21
1.5.9 18
1.5.12 17
1.8.1 46
1.8.7 48
1.8.19 48
1.8.20 50
1.9.1.1 100
1.9.1.3 101
1.9.1.5 105
1.9.1.7 107
1.9.1.9 108, 111
1.9.2.1 109
1.9.2.4 94
1.9.2.8 121
1.9.2.13 109
1.9.2.16 95, 122
1.9.6.1 95, 98, 123
1.9.6.2 121

1.9.6.13 124
1.9.7.1 95, 109, 111, 125
1.9.7.3 96, 126
1.9.7.4 96, 127, 129
1.9.7.5 96, 128
1.9.7.13 129
1.9.9.1 121
1.9.9.6 98
1.9.11 121
1.9.13 110, 130
1.9.14 111, 129
1.9.24 98
1.10.1.24 43
1.10.2.5 84
1.10.2.6 82
1.22.1 155
1.22.4 142
1.22.13 156, 157
1.22.16.1 165
1.22.16.4 165
1.22.16.7 165
1.22.16.9 166
1.22.16.13 167
1.22.16.16 168
1.22.19 150
1.22.22 155
1.22.23 152
1.22.24 136
2.1.1 176, 177
2.1.7 179
2.1.13 175
2.3.1 180, 183
2.3.13 180
2.5.1 174
2.5.16 175
2.11 194
2.12 173, 274
2.13.1.1 254

| | | | |
|-----------|----------|----------|----------|
| 2.13.1.2 | 254 | 3.7 | 223 |
| 2.13.1.3 | 254 | 3.8 | 223 |
| 2.13.1.5 | 255 | 3.9 | 222 |
| 2.13.1.6 | 255 | 3.10 | 222 |
| 2.13.1.7 | 255 | 3.11 | 222 |
| 2.13.1.9 | 256 | 3.12 | 222 |
| 2.13.1.13 | 263 | 3.13 | 228 |
| 2.13.1.17 | 257 | 3.14 | 229 |
| 2.13.1.18 | 257 | 3.15 | 229 |
| 2.13.1.19 | 257 | 3.16.2 | 238 |
| 2.13.1.22 | 262 | 3.16.4 | 237 |
| 2.13.1.23 | 262 | 3.16.6 | 238 |
| 2.13.3.1 | 249 | 3.16.7 | 239 |
| 2.13.3.14 | 252 | 3.16.8 | 238 |
| 2.13.3.15 | 252 | 3.16.12 | 239 |
| 2.13.5.1 | 259, 260 | 3.16.13 | 238 |
| 2.13.13.1 | 267 | 3.16.15 | 238, 239 |
| 2.13.13.5 | 271 | 3.16.18 | 239 |
| 2.13.24 | 261, 272 | 3.16.21 | 237, 240 |
| 2.17.1 | 181 | 3.16.23 | 236, 238 |
| 2.19.1 | 184 | 3.17 | 233 |
| 2.20.1 | 191 | 3.18 | 233 |
| 2.20.4 | 192 | 3.19 | 233 |
| 2.20.7 | 192 | 3.21 | 225 |
| 2.20.10 | 193 | 3.21.1 | 225 |
| 2.21.1 | 182 | 3.21.2 | 225 |
| 2.21.2 | 183 | 3.21.13 | 225 |
| 2.21.3 | 183 | 3.21.14 | 226 |
| 2.22.1.16 | 202 | 3.21.16 | 226 |
| 2.22.1.19 | 202 | 3.21.23 | 226 |
| 2.22.1.22 | 202 | 3.22 | 226 |
| 2.22.3 | 205 | 3.22.1 | 226 |
| 2.22.11 | 210 | 3.22.2 | 226 |
| 2.22.13 | 211 | 3.22.3 | 226 |
| 2.22.19 | 212 | 3.22.4 | 227 |
| 2.22.20 | 214 | 3.23 | 31 |
| 3.3 | 233 | 3.24 | 18, 218 |
| 3.4.1 | 221 | 5.13.1 | 189 |
| 3.4.2 | 221 | 5.24 | 88, 189 |
| 3.4.3 | 221 | 7.1.11 | 71 |
| 3.4.4 | 221 | 13.5 | 90 |
| 3.6.1 | 230 | 13.13.3 | 97 |
| 3.6.2 | 230 | 13.13.22 | 97 |
| 3.6.3 | 18, 230 | 14.22 | 97 |
| 3.6.5 | 231 | 15.5 | 90 |
| 3.6.6 | 231 | 15.22 | 97 |
| 3.6.8 | 231 | 19.1.13 | 90 |
| 3.6.9 | 232 | 19.1.22 | 97 |
| 3.6.13 | 232 | 36.2.17 | 105 |
| 3.6.14 | 232 | 36.3.24 | 98 |
| 3.6.15 | 232 | 36.13.2 | 97 |
| 3.6.16 | 232 | 36.14.1 | 97 |

36.14.3 97

A

ABC class codes 18, 228

ABC Status Report/Update 18

absorbed taxes 283

accounts

inventory 25

product line 24

sales 26

accounts payable (AP)

tax account 281

Accounts Payable Control File

tax variances 300

accrual

price list 53, 63

action status

sales order repricing 73

activating

compliance 137

Intrastat 203

additive discounts 43

Address Code Change 194

addresses 170–194

address file relationships 171

banks 182

bill-to 174

carriers 181

company 173

GTM 274

customer 175

declarants and agents 202

employee 181

Intrastat 207

list type 172

merging 195

printing on forms 174

salesperson 174

ship-to 174

site

GTM 274

supplier 180

advanced repetitive

compliance effect 138, 159

transactions

inventory attributes 140, 145

agent

selecting for Intrastat print 213

aggregate taxes 277

allocate single lot 19

Allocated Inventory Inquiry 233

alternate

product line accounts 25

amount type

accrual 53

credit terms 53

discount % 53

discount amt 53

freight list 53

freight terms 53

list price 53

list/discount table pricing 82

markup 53

net price 53

Analysis Code Copy 50

Analysis Code Detail Build 48

Analysis Code Detail Inquiry 50

Analysis Code Detail Maintenance 49

Analysis Code Link Maintenance 48

Analysis Code Maintenance 46

Analysis Code Report 46

Analysis Code Selection Maintenance 46

Analysis Code Where-Used Inquiry 50

analysis codes 44–50

Automatic AC Regen 43

automatic build 49

building 48

child 48

combining into groups 48

conditions 46, 47

copying 50

customer conditions 47

item conditions 47

linking 48

parent codes 48

planning 42

rules 48

setting up 44

AP Tax by Tax Rate Report 319

AP Tax by Transaction Report 319

approval

group for PCC 106

product change order 104, 123

Approval Browse 121

AR Tax by Tax Rate Report 319

AR Tax by Transaction Report 319

archive/delete

Intrastat records 215

assay% 141

changing 149

definition 143

attributes. *See* inventory attributes

authority codes 165

auto lot numbering 154, 156

- effects of 156
- gaps in sequence of 156
- lot groups 158, 159
- automatic
 - analysis code regeneration 43
 - locations 31
 - lot numbers 18
- average cost
 - non-recoverable tax 313
 - purchase variances 309
 - recoverable tax 308
 - tax accrual for memo items 312
 - tax accrual for returned items 312
 - tax calculation 308
 - tax for inventory items 309
- average interval 18
- B**
- Backflush Transaction
 - automatic lot numbers 159
- banks
 - addresses 182
 - company address 173
 - defining accounts 183
 - supplier 182
- base date 185
- base days
 - base date and 188
 - in inflationary environments 188
- batch numbers
 - assigning to work orders 148
 - benefits 135
 - concept 147
 - effects of using 147
 - example 148
 - work flow 148
- Batchload Transfer With Lot/Serial Change 221
- best pricing 40–78
 - analysis codes 44
 - calculating 56
 - combining discounts 54
 - configured items 56
 - control file defaults 43
 - discount types 53
 - planning 41
 - price lists 60
 - reports 68
 - repricing 71
 - Sales Order Maintenance 74
- break categories 41, 51, 55
- Break Category field 51
- building
 - analysis codes 49
 - Lot Master File 155
- Bulk Tag Create 238
- burden
 - item cost category 21
- C**
- capped taxes 280
- Carrier Maintenance 181
- cascading discounts 43
- category
 - break 51
- CIM interface
 - inventory transfer 221
- classes
 - freight 192
 - tax 254
- Closed AR Delete/Archive
 - temporary addresses 176
- closing
 - PCO to PCO 112
 - PCR/PCO 129
- codes
 - vs master comments 17
- combinable discounts 54
- commissions 174
- Commodity Code Maintenance 205
- commodity codes 204, 205
 - associating with a country 206
- Company Address Maintenance 173
 - GTM requirements 274
 - Intrastat addresses 207
- company addresses
 - banks 173
 - converting tax info 274
 - country code field 207
 - purchase order 173
 - setting up for Intrastat 207
 - taxes 174
- compliance 134–168
 - automatic lot numbers 156
 - Compliance Control File 136
 - controlled substances 162
 - inventory attributes 139
 - lot control features 151
 - setting up 136
 - work order batch control 139
- Compliance Control File 136
 - Compliance Active field 137
- component issue control
 - benefits 135
 - restricting to BOM 162

- compound interest
 - credit limit calculation 179
- configured items
 - pricing 56, 62
- control file
 - Compliance 136
 - Global Tax Management 272
 - Intrastat 202
 - Inventory 218
 - Pricing 43
- Controlled Authority Maintenance 165
- Controlled Customer Maintenance 165
- Controlled Item Maintenance 166
- Controlled Site Maintenance 165
- controlled substances
 - benefits 136
 - interaction with MFG/PRO eB 162
 - work flow 163
- conversion
 - PCR to PCO 113
- cooperative marketing 42
- co-products/by-products
 - compliance 137
 - modifying receipts 137
- copying
 - analysis codes 50
 - PCOs from PCRs/PCOs 112
 - PCOs to PCR/PCO 112
 - price lists
 - best prices 65
 - list/discount table 84
 - tax rates 271
- cost data 14
- Country Code Browse 249
- Country Code Maintenance 201, 249
 - compliance 164
- Country Code Report 249
- country codes 249
 - alternate 249
 - DEA country 250
 - defining for compliance 164
 - EC country 249
 - for company address 207
 - for customers and suppliers 207
 - GATT country 250
 - groups 250
 - NAFTA country 250
 - name 249
 - setting up 249
 - type 250
- Country of Dest/Disp field 203
- county codes
 - GTM 250
- credit limit
 - adjusting 179
 - calculating 180
 - checking in sales order repricing 72
 - methods of calculating 179
 - update 180
- credit terms 184
 - adjusting entries not calculated 189
 - base date 185
 - base days 188
 - interest 185
 - price list 53
 - proximo 185
 - purchasing transactions 189
 - sales transactions 189
 - two levels 184
- credit terms interest 187, 188
 - default 188
- Credit Terms Maintenance 184, 188
 - proximo terms 186
- currency
 - price lists 60
- Current Surplus Inventory Report 231
- Customer Credit Limit Adjustment 179
- Customer Item Maintenance 22
- Customer Maintenance 176, 177
 - Intrastat country codes 207
- Customer Orders by Price List Inquiry 69
- Customer Ship-to Maintenance 175
- Customer/Supplier Bank Browse 183
- Customer/Supplier Bank Maintenance 182
- Customer/Supplier Bank Report 183
- customers 175
 - analysis codes regeneration 43
 - banks 182
 - bill-to 175
 - country codes 207
 - credit data 177
 - default GTM tax data 274
 - freight data 178
 - ship-to 175
 - sold-to 175
- Cycle Count Results Entry 229
- Cycle Count Results Report 229
- Cycle Count Worksheet Print 228
- cycle counting 34, 228
 - initial counts 229
 - interval 19
 - recounts 229
 - results report 229

D

- date
 - PCO effective 127
 - pricing effective 23
 - reference 204
- declarant
 - selecting for Intrastat print 213
- Declarant Branch ID field 204
- declarations
 - printing Intrastat 212
 - reprinting 214
 - selecting for final print 212
- default
 - inventory status 144
- delete/archive
 - Intrastat records 215
 - inventory tags 236
 - lot masters 152
- Detail Approval Maintenance 124
- discount tables 78
 - requiring 88
- discount types
 - accrual 53
 - credit terms 53
 - discount % 53
 - discount amt 53
 - freight list 53
 - freight terms 53
 - list price 53
 - markup 53
 - net price 53
- discounted taxes 282
- discounts 43
 - additive example 58
 - base 54
 - base-combinable 54
 - cascading example 58
 - combinable 54
 - combination type 43
 - exclusive 54
 - pricing 70
 - quantity 71
 - sequence order 58
 - volume 43, 71
 - volume discounts 43
- distribution group 109
- E**
 - EC Sales Listing 281, 319
 - ECO. *See* engineering change order (ECO)
 - effective dates
 - setting for PCOs 127

- E-mail
 - during PCC routing 106
- Employee Maintenance 181
- employees 181
- Enable PCC Formula Maintenance 97
- Enable PCC Item Spec Maintenance 97
- Enable PCC Routing Maintenance 97
- Enable PCC Structure Maintenance 97
- engineering change order (ECO)
 - printing 97
 - replaced by PCC module 90
 - turning off functionality 97
- entities
 - general ledger (GL) 29
 - Site Maintenance 29
- environments
 - tax 258
- error codes
 - GTM environment 261
 - GTM tax zone 253
- EU. *See* European Union (EU)
- European Community (EC) 249
 - EC process work 269
 - EC sales list 269, 281
- European Union (EU)
 - Country Code Maintenance 249
 - Intrastat reporting 197
- exemptions 276
- expire date
 - changing 149
 - defined 143
 - inventory 141
- expired
 - inventory
 - management 151
 - transactions 161
- exploded nodes
 - analysis codes 49
- export
 - PCR/PCO 130
- Export Control Classification Numbers 162
- F**
 - factors 43
 - fixed interest (credit limit calculation) 179
 - fixed prices
 - sales orders 71
 - Flow Indicator Maintenance 201
 - formats
 - VAT registration 275
 - Formula Maintenance 90
 - formulas

- and assay% 143
- and grade 143
- freezing inventory balances 237
- freight charges 189–194
 - freight class 192
 - freight lists 190
 - freight terms 193
 - freight zones 191
- Freight Charges Maintenance 193
- Freight Class Maintenance 192
- Freight List Maintenance 191
- freight lists
 - price list 53
- freight terms 193
 - price list 53
- Freight Zone Maintenance 192

G

- general ledger (GL)
 - accrued tax at receipt 281
 - AP tax account 281
 - cost categories 21
 - GTM effects 296
 - tax accounts 265
- General License Maintenance 167
- general licenses
 - defining 167
- Generalized Codes Maintenance
 - county codes 250
 - province codes 250
 - state codes 250
- geographical area 42
- Global Tax Management (GTM)
 - addresses 174
 - calculating taxes
 - custom methods 278
 - standard methods 278
 - concepts 245
 - correcting amounts 295
 - GL effects 296
 - implementing 247
 - limitations 245
 - partial item amounts 278
 - processing taxes 287
 - rounding methods 257
 - sample scenario 246
 - setup
 - addresses 274
 - control file 272
 - country codes 249
 - customer tax data 274
 - customers 274

- GL accounts 265
- item tax class 276
- tax bases 263
- tax classes 254
- tax environments 258
- tax rates 266
- tax types 254
- tax usages 254
- tax zones 250
- tax calculation logic 288
- tax data windows 291
- tax exemptions 276
- tax methods 278
- troubleshooting 320
- viewing tax amounts 293
- Global Tax Management Control File 272
 - country code 250
 - Tax Environment field 261
- GMP. *See* U.S. FDA Good Manufacturing Practices
- grade 141
 - changing 149
 - defined 143
- Group Maintenance 100
 - adding users 101
- groups
 - PCC 100
 - adding users 102
 - approval 106
 - replacing users 103, 104
 - product change control (PCC)
 - distribution 109
- GTM. *See* Global Tax Management (GTM)

H

- Harmonized Tariff Codes 162
- Health Industry Numbers 162

I

- Implementation (PCO) 129
- import
 - PCR/PCO 130
- Incorporation (PCO) 96, 128
- Incorporation Planning Report 96, 126
- Incorporation Selection 96, 127, 129
- Individual License Maintenance 168
- individual licenses
 - defining 168
- initializing PCOs 98
- inquiries
 - Intrastat 214
 - memory considerations 227
 - workfiles and 227

- Intrastat 197–216
 - audit trail information 216
 - data for orders 208
 - delete/archive records 215
 - features 198
 - inquiries and reports 214
 - manual update of records 211
 - order maintenance
 - example 208
 - printing declarations 212
 - qualitative information 216
 - quantitative information 216
 - region code 207
 - setting up 200
 - addresses for declarants and agents 202
 - codes 201
 - commodity codes 205
 - company addresses 207
 - country codes 207
 - Intrastat item data 206
 - item net weight 208
- Intrastat Control File 202
- Intrastat Declaration Print 212
- Intrastat Declaration Reprint 214
- Intrastat Inquiry 214
- Intrastat Inquiry by Invoice 214
- Intrastat Inquiry by Order 214
- Intrastat Inquiry by Voucher 214
- Intrastat Item flag
 - changing to Yes 210
- Intrastat Maintenance 209, 211
- Intrastat Net Weight Minimum field 203
- Intrastat Net Weight Unit of Measure field 203
- inventory 217–233
 - accurate balances 34
 - availability 33
 - checking availability 233
 - data 14, 17
 - detail records 220
 - impact of PCO 126
 - issues
 - restrictions 33
 - location 30
 - negative balances 34
 - nettable 33
 - not available 33
 - overissue 35
 - overissue flag 34
 - picking 218
 - sites 27
 - status codes 33
 - total 220
 - transaction effective date 204
 - transactions 34
 - updating balances 240
- Inventory Account Maintenance 25
- inventory attributes 140
 - changing 149
 - compliance 135, 139
 - field security 149
 - search order 146
 - status 140
- Inventory Balance Freeze 237
- Inventory Balance Update 237, 240
- inventory codes
 - ABC Class 18
 - allocate single lot 19
 - automatic lot numbers 18
 - average interval 18
 - cycle count interval 19
 - location 18
 - location type 18
 - lot/serial control 18
 - shelf life 19
 - site 18
- Inventory Control File 218
 - ABC tolerances 228
 - cycle counting 227
 - location search order 30
 - Site 18
- Inventory Detail by Item Browse 233
- Inventory Detail by Location 231
- Inventory Detail by Site Browse 233
- Inventory Detail Report 231
- inventory reports
 - Current Surplus Inventory Report 231
 - Inventory Detail by Location 231
 - Inventory Detail Report 231
 - Inventory Valuation as of by Loc 232
 - Inventory Valuation as of Date 232
 - Inventory Valuation by Location 232
 - Inventory Valuation Report 232
 - Item ABC Status Report/Update 230
 - Projected Surplus Inventory 232
 - Reorder Report 230
 - Stock Status Report 230
- inventory status
 - blank 146
 - changing 144, 149
 - compliance effect 140
 - PO Receipt Status 141
 - WO Receipt Status 141
- Inventory Status Code Maintenance 33
- inventory transactions 220, 221

- expired 161
 - issues 223
 - receipts 222
 - shipments 223
 - Inventory Valuation as of by Location 232
 - Inventory Valuation as of Date 232
 - Inventory Valuation by Location 232
 - Inventory Valuation Report 232
 - Inventory Variance Report 239
 - Invoice Post
 - Intrastat records created 203
 - issues 223
 - inventory transactions 223
 - Issues–Return to Supplier 223
 - Issues–Unplanned 223
 - Item ABC Status Report/Update 230
 - Item Data Maintenance 90, 113
 - Item Intrastat Data Maintenance 206
 - item inventory data 18
 - Item Inventory Data Maintenance 18
 - auto lot numbering 156
 - Cycle Count Interval field 228
 - Item Master Comments Report 17
 - Item Master Copy
 - auto lot numbering 156
 - Item Master Maintenance 14
 - auto lot numbers 156
 - Cycle Count Interval field 228
 - lot groups 158
 - Price Break Cat field 52
 - Item Revision History Inquiry 98
 - Item Specification Maintenance 90
 - items 13–22
 - ABC classification 17
 - alternate unit of measure 16
 - analysis codes regeneration 43
 - and generalized codes 15
 - cost data 21
 - customer items 22
 - data 13
 - general data 15
 - GL cost 21
 - groups 16
 - in multiple sites 14
 - Intrastat setup 206
 - inventory data 17
 - net weight for Intrastat 208
 - numbering 15
 - numbers as indexes 15
 - PCR/PCO update of 113
 - planning 19, 20
 - price break categories 41, 51
 - price default 21
 - Pur/MFG code 20
 - supplier items 22
 - types 16
 - unit of measure 16
 - Item-Site Cost Maintenance 21
- ## L
- life cycle of a PCR/PCO 93
 - linking
 - analysis codes 45, 48
 - List Price price list 64
 - list type (address) 172
 - list/discount table pricing 78–88
 - Location Maintenance 30, 31
 - locations 30–35
 - and picklists 30
 - automatic 31
 - naming conventions 30
 - overview 30
 - permanent/temporary 31
 - single item 32
 - types 32
 - Lot Actual Bill Inquiry 226
 - batch number display 149
 - lot control
 - benefits 135
 - building Lot Master File 155
 - compliance features 151
 - database level 153
 - deciding on level 154
 - effects of turning off 151
 - item level 153
 - Item Master Maintenance 18
 - levels 137, 151
 - order level 153
 - work flow 152
 - Lot Control Level field 137
 - Lot Group Maintenance 156
 - lot groups
 - assigning to items 158
 - creating 156
 - Lot Master Delete/Archive 152
 - Lot Master File
 - building 155
 - modifying 155
 - Lot Master Maintenance 155
 - expired inventory transaction 161
 - lot numbers
 - assigned prior to activating Compliance 152
 - auto lot numbering 151, 156
 - compliance 137

- expired inventory 161
- Lot Level Control field 144
- multiple-database 151
- reusing 151
- supplier 151, 160
- Lot Transactions by Date Browse 226
- Lot Transactions by Date Inquiry
 - batch number display 149
- Lot Transactions by Tran Inquiry 226
- Lot Where-Used Inquiry 227
 - batch number display 149
- Lot/Serial Number History Menu 226
- luxury taxes 280

M

- Maintain Users in Groups 101
 - adding users 102
 - removing users 104
 - replacing users 103
- manual price lists 76
- master
 - comments
 - copying text into PCO 113
 - vs codes 17
- material requirements planning (MRP)
 - item planning data 19, 20
- memo items
 - Intrastat 204
 - tax accrual 307
- Menu Password Maintenance
 - PCO update access 131
- minimum price 43
- Mode of Transport field 204
- Mode of Transport Maintenance 202
- Move Transaction
 - automatic lot numbers 159
- Multi-Lot Inven. Detail Update 149
- multiple databases
 - site codes 28

N

- NAFTA 250
- National Drug Codes 162
- Nature of Transaction Maintenance 201
- net weight
 - item data for Intrastat 208
- nodes
 - analysis codes 49
- non-recoverable tax 303
- notification
 - PCC approvals 105
- numbers

- auto lot 151
- items 15
- PCR/PCO 98

O

- OR logic 45, 48
- Order Intrastat Data Maintenance 210
- overissues 34, 35

P

- PCC Control File 98
- PCC. *See* product change control (PCC)
- PCO Maintenance 109–121
 - Formula File Maintenance
 - Copy Formula into PCO 118
 - Copy Where Used into PCO 118
 - PCR/PCO Detail Maintenance–Formulas 118
 - Replace Formula Component 118
 - header 110
 - Item File Maintenance 113
 - Add, Modify, Delete PCO Item Files 113
 - Direct Item Master Access 114
 - Item Specification Maintenance
 - Add/Edit/Deactivate Item Specification 119
 - Copy Item Spec From Quality Module 120
 - PCO/PCR Function Maintenance
 - Change PCO Number 112
 - Close PCO to PCO 112
 - Copy PCO from PCR/PCO 112
 - Copy PCO to PCR/PCO 112
 - Process File Maintenance 119
 - Routing File Maintenance
 - Add/Edit/Deactivate Routing 117
 - Add/Edit/Deactivate Routing (Rate Based) 118
 - Copy Routing to PCR/PCO 118
 - Section Menu 111
 - Structure File Maintenance 115
 - Copy Product Structures into PCO 115
 - Copy Where Used into PCO 115, 116
 - Product Structure detail 116
 - Replace Product Structure Component 116
 - Text File Maintenance 113
 - Add, Modify, Delete PCO Text Files 113
 - Copy Text from Master Comments 113
 - Trailer Maintenance 120
- PCO Status Browse 121
- PCO. *See* product change order (PCO)
- PCR Maintenance 109
 - PCO/PCR Function Maintenance
 - Close PCR to PCO 112
 - Convert PCR to PCO 113
- PCR. *See* product change request (PCR)

- PCR/PCO Approval 95, 98, 123
- PCR/PCO Close 111, 129
- PCR/PCO Detail Inquiry 121
- PCR/PCO Import/Export 110, 130
- PCR/PCO Type Maintenance 108, 111
- permanent locations 31
- physical inventory 235–240
 - creating and printing tags 237
 - deleting/archiving old tags 236
 - freezing inventory balances 237
 - reviewing results 239
 - Tag Recount Entry 239
 - Updating Inventory Balances 240
- picking logic 218
 - inventory 218
 - options 219
- planning
 - data 14, 19, 20
- PO Receipt 189
- Port Maintenance 202
- Port of Transshipment field 204
- Preference Criteria Codes 162
- Price by Line Due Date field 88
- Price List Copy (1.10.1.8) 65
- Price List Copy (1.10.2.5) 84
- Price List Generation by Item 82
- Price List Inquiry 64
- Price List Maintenance (1.10.1.1) 60
- Price List Maintenance (1.10.2.1) 78
- Price List Report 64
- price lists
 - Combination Type field 61
 - copying 65
 - creating 52
 - Disc Sequence field 62
 - incremental 54
 - List Price 64
 - manual 76
 - Quantity Type field 61
 - requiring 88
 - unit of measure 60
- Price Lists by Customer Inquiry 65
- Price Lists by Item Inquiry 65
- pricing
 - analysis codes 44
 - assigning lower net 57
 - best pricing 40
 - break categories 41, 51
 - calculating best 57
 - effective date 43, 44
 - inquiries 68
 - list/discount table 78
 - promotional discount 42
 - tables 78
- Pricing Control File 43
- Pricing What-If Inquiry 68
- Print PCR/PCO 121
- printing
 - cycle count worksheets 228
 - ECO 97
 - Intrastat declarations 212
 - tax information 319
 - VAT registration numbers 273
- processes
 - PCR/PCO update of 119
- product change control (PCC)
 - auto numbering 98
 - security 98
 - setting up 96
 - user IDs 97
- product change order (PCO)
 - adding, modifying, and deleting text files 113
 - approval 95, 123
 - auto numbering of 110
 - changing numbers 112
 - closing 129
 - closing PCO to PCO 112
 - copying from PCR/PCO 112
 - copying to PCR/PCO 112
 - data affected by 90
 - database 110
 - distribution 125
 - effective dates 92, 127
 - evaluating impact on inventory 126
 - ID 110
 - implementation 96, 129
 - importing and exporting 130
 - incorporating into production files 128
 - incorporation 96
 - initializing 98
 - item file maintenance 113
 - item/site data not maintained by 91
 - life cycle 93, 94
 - master comment 113
 - multi-database installations and 110
 - overview 91
 - prefixes for numbers 99
 - printers and batch IDs 97
 - process file maintenance 119
 - product structures in 115
 - release 125
 - release and distribution 95
 - reopening 120
 - rerouting 124

- revision levels 114
- routing for approval 95, 122
- security issues 130
- text file maintenance 113
- trailer maintenance 120
- types of data in 109
- viewing data 121
- product change request (PCR)
 - approval 94
 - life cycle 93
 - routing for approval 94, 122
 - types of data in 109
- product definition 5, 11
- Product Line Maintenance 25
- product lines 22–26
 - accounts 24
 - alternate accounts 25
 - defining 22
- Product Structure Maintenance 90
- product structures
 - maintaining in PCR/PCO 115
 - restricting component issues to 162
- Projected Surplus Inventory 232
- promotions prefix
 - pricing 44
- province codes 250
 - GTM 250
- proximo terms 185
 - use of 185
 - ways to set up 186
- pt_um 16
- Pur/Mfg code 20
- Purchase Order Receipts
 - attributes 145
 - auto lot numbering 159
- purchase orders 140
 - compliance 138
 - single lot per receipt 138
- purchase price variance 304
- purchase receivers
 - and Intrastat 203
- Purchasing Control File 189
 - pricing fields 88

Q

- quality management
 - PCC control of item specifications 119
- quotes. *See* sales quotes

R

- rates
 - GTM tax 266

- Reason Codes Maintenance
 - severity lists 105
- receipts
 - inventory 222
 - status 141
- receipts status
 - defined 143
- Receipts–Backward Exploded 222
- Receipts–Return to Stock 222
- Receipts–Sales Order Return 222
- Receipts–Unplanned 222
- recoverable taxes 280, 297
 - account 265
- Reference Date Logic field 204
- region code
 - for Intrastat declarations 207
- Region Maintenance 202
- Regional Value Content 162
- registration
 - VAT 275
- Release and Distribution 95, 109, 111, 125
- Reorder Report 230
- repetitive
 - receipts
 - compliance 138
 - single lot per receipt 138
 - transactions
 - inventory attributes 140, 145
- Repetitive Labor Transaction
 - auto lot numbering 159
- reports
 - Intrastat 214
 - tax 319
- Reprice field 74
- repricing
 - sales orders and quotes 71
- reprinting
 - Intrastat declarations 214
- restricting component issues 162
- retained tax account 265
- retained taxes 283
- returned items
 - tax accrual 307
- reverse-calculated taxes 283
- revision levels
 - PCC 114
- Rounding Method Browse 257
- Rounding Method Maintenance 257
- Rounding Method Report 257
- rounding methods
 - global tax management (GTM) 256
 - thresholds 257

- unit 257
 - Route PCO for Approval 95, 122
 - Route PCR for Approval 94
 - Routing Slip Copy 107
 - Routing Slip Maintenance 105
 - details 106
- S**
- Sales Account Maintenance 26
 - Sales Order Control File
 - accounts 189
 - pricing fields 88
 - Sales Order Maintenance
 - Global Tax Management (GTM) 291
 - Intrastat data 208
 - pricing fields 76
 - repricing 74
 - Transaction Tax Detail frame 293
 - View/Edit Tax Details 293
 - Sales Order Manual Allocations
 - allocate single lot 19
 - Sales Order Price Inquiry 70, 74
 - Sales Order Pricing Report 75
 - Sales Order Repricing 71
 - sales orders
 - customer address 175
 - Display SO Discounts as 44
 - price lists. *See* best pricing
 - Price SO by Line 44
 - repricing 71
 - SO Default Price Date 44
 - SO Factor Rounding 44
 - tax adjustments 285
 - Sales Quote Price Inquiry 74
 - sales quotes
 - customer address 175
 - Display QO Discounts as 44
 - Price QO by Line 43
 - QO Default Price Date 43
 - QO Factor Rounding 43
 - repricing 71
 - sales tax
 - absorbed account 265
 - account 265
 - Salesperson Maintenance 174
 - Salesperson Payments Report 175
 - salespersons
 - commissions 174
 - territory codes and 174
 - security
 - PCR/PCO 98
 - Product Change Control module 130
 - Security Control File
 - PCO and PCR security 98
 - sequences
 - discount 58
 - GTM tax types 260
 - setting up
 - country codes 249
 - Intrastat
 - addresses for declarants and agents 202
 - PCC module 97
 - severity level 107
 - severity list 105
 - shelf life 19
 - ship-to addresses
 - temporary 176
 - Ship-To Maintenance
 - Intrastat country codes 207
 - simple interest (credit limit calculation) 179
 - single item locations 32
 - single lot
 - per PO receipt 138
 - per receipts 144, 151
 - Site Maintenance 29, 30, 31
 - site security
 - compliance 134
 - Site Security Maintenance
 - and compliance 134
 - sites 27–30
 - address records 274
 - multiple databases 28
 - overview 27
 - setting up 28
 - uses of 27
 - standard cost
 - GTM taxes 297
 - inventory items 298
 - non-recoverable tax 303
 - recoverable tax 297
 - tax for returned items 307
 - taxes for inventory items 303
 - taxes for memo items 302
 - taxes for returned items 302
 - variances 299
 - state codes 250
 - GTM 250
 - Statistical Procedure Maintenance 202
 - statistical value
 - calculating Intrastat 216
 - status
 - inventory 33, 140
 - PCR/PCO 121
 - Stock Availability Browse 233

- Stock Status Report 230
- substitute items
 - restricting issues to 162
- sums-into relationships 252
- sums-into zone 251
- Supplier Item Maintenance 22
- Supplier Maintenance 180
 - bank account window 183
 - banks 183
 - Intrastat country codes 207
- Supplier Remit-to Maintenance 180
- suppliers 180
 - banks 182
 - country codes 207
 - lot numbers 151, 160

T

- Tag Count Entry 239
- Tag Delete/Archive 236, 238
- Tag Inquiry 238
- Tag Print 238
- Tag Recount Entry 239
- Tag Report 238
- Tag Void Status Update 239
- tax accrual 304
- Tax Base Maintenance 263
- tax bases 263
- Tax Class Browse 255
- Tax Class Maintenance 255
- Tax Class Report 255
- tax classes 254
- Tax Detail by Transaction Inquiry 319
- Tax Detail by Transaction Report 319
- Tax Environment Maintenance 259, 260
- tax environments 258
 - examples 258
 - selection criteria 289
 - setting up 259
- tax exemptions
 - GTM 276
- Tax Rate Copy/Update 271
- Tax Rate Maintenance 267
- tax rates 266
 - copying 271
 - selecting 289
 - setting up 267
- tax reporting
 - aggregate tax 277
 - by exemption 277
- Tax Type Inquiry 254
- Tax Type Maintenance 254
- Tax Type Report 254

- tax types 254
- Tax Usage Maintenance 256
- tax usages 254
- Tax Zone Inquiry 252
- Tax Zone Maintenance 252
- Tax Zone Report 252
- tax zones 250
 - error codes 272
 - hierarchies 251
 - sums-into 251
- taxes
 - absorbed 283
 - accrued 270
 - capped 280
 - company address 174
 - correcting 295
 - discounted 282
 - luxury 280
 - processing 287
 - recoverable 280, 297
 - reporting 319
 - reports 319
 - retained 283
 - reverse-calculated 283
 - rounding methods 257
 - tax-on-tax 281
 - troubleshooting 320
 - viewing amounts 293
- tax-on-tax 263
- temporary locations 31
- terms
 - credit 184
 - delivery 201
 - freight 193
- Terms of Delivery Maintenance 201
- Trailer Code Maintenance 189, 262
- trailer codes
 - defaults 189
 - tax status 261
 - taxable 189
- Trailer Tax Detail Browse 262
- Trailer Tax Report 262
- Transaction by Item Inquiry 225
- Transaction Detail Inquiry 225
 - batch numbers 149
- Transaction History Menu 225
- transaction types
 - expired inventory 161
 - inventory 224
- Transactions Accounting Report 226
- Transactions by Item Report 226
- Transactions by Order Report 225

- Transactions Delete/Archive 226
- Transfer With Lot/Serial Change 221
- Transfer–Multi Item 221
- transfers
 - inventory 221
- Transfer–Single Item 221
- triangulation
 - Intrastat 207
- troubleshooting
 - common GTM problems 320
- type
 - inventory transactions 224
 - location 32
 - PCR/PCO 108
 - tax 254

U

- Unallocated Inventory Inquiry 233
- Uncounted Tag Report/Update 238, 239
- unit of measure 16
 - acceptable values 16
 - alternates 16
- usages
 - tax 254
- Use Intrastat field 203
- User Maintenance
 - PCC groups 97
- users
 - adding to PCC groups 101

V

- Value Added Tax (VAT)
 - registration formats 275
 - registration numbers

- printing 273
- variable overhead 21
- VAT Registration Number Report 319
- VAT. *See* Value Added Tax (VAT)
- Void/Zero Count Unused Tags 239
- volume discounts 43
- voucher date
 - Intrastat 204
- Voucher Maintenance
 - Intrastat effect 205

W

- Work Order Attribute Maintenance 139
- Work Order Batch Inquiry
 - batch number display 149
- Work Order Bill Maintenance
 - allocate single lot 19
 - restricting component issue 162
- Work Order Maintenance
 - inventory attributes 139
- Work Order Receipt
 - attributes 145
 - auto lot numbering 159
- work orders
 - and component issues 162
 - compliance 138
 - inventory attributes 139
 - single lot per receipt 138

Z

- Zero Balance Delete/Archive 31
- zones
 - freight 191
 - GTM 250

