



QAD Enterprise Applications
Enterprise Edition

User Guide
QAD Scheduled Order
Management

Customer Schedules
Supplier Schedules
Trade Sales

70-3179-2016EE
QAD Enterprise Applications 2016
Enterprise Edition
March 2016

This document contains proprietary information that is protected by copyright and other intellectual property laws. No part of this document may be reproduced, translated, or modified without the prior written consent of QAD Inc. The information contained in this document is subject to change without notice.

QAD Inc. provides this material as is and makes no warranty of any kind, expressed or implied, including, but not limited to, the implied warranties of merchantability and fitness for a particular purpose. QAD Inc. shall not be liable for errors contained herein or for incidental or consequential damages (including lost profits) in connection with the furnishing, performance, or use of this material whether based on warranty, contract, or other legal theory.

QAD and MFG/PRO are registered trademarks of QAD Inc. The QAD logo is a trademark of QAD Inc.

Designations used by other companies to distinguish their products are often claimed as trademarks. In this document, the product names appear in initial capital or all capital letters. Contact the appropriate companies for more information regarding trademarks and registration.

Copyright ©2016 by QAD Inc.

SchedOrderMgmt_UG_v2016EE.pdf/crl/mat

QAD Inc.

100 Innovation Place
Santa Barbara, California 93108
Phone (805) 566-6000
<http://www.qad.com>

Contents

Scheduled Order Management	
Change Summary	ix
Chapter 1 Scheduled Order Management	1
Overview of Scheduled Order Management	2
Customer and Supplier Information Exchange	2
Origins of Scheduled Order Management	2
Scheduled Order Management Flow	3
Characteristics of Schedules	3
Customer Schedules	5
Customer Sequence Schedules	7
Supplier Schedules	7
Supplier Shipping Schedules	8
Trade Sales	9
Trade Sales Process	9
Section 1 Customer Schedules	15
Chapter 2 Customer Schedules	17
Managing Customer Schedules	18
Using Netting Logic	18
Determining Open Days for Netting Logic	19
Calendar Options, RSS, and Netting Logic	20
Using PCR Quantities with Netting Logic	21
Setting Up Customer Schedules	22
Setting Up Schedule Data	22
Setting Up Control Program Values	27
Setting Up Categories for Requirement Detail	27
Setting Up Configured Messages	28
Creating Customer Scheduled Orders	31
Scheduled Order Header Frame	31
Salesperson Frame	36
Non-Cumulative Quantity Accounting Data Frame	37

Order Line Item Identification Frame	38
Order Line Item Data Frame	39
Viewing Schedule Order Information	43
Processing Customer Schedules	43
Importing Schedules with EDI eCommerce	43
Entering or Verifying the Release	44
Creating a Required Ship Schedule	48
Viewing Schedule Information	51
Running MRP	51
Processing Shipments	51
Printing Bills of Lading	54
Pegging Requirement Detail	54
Consuming Requirements	56
Cumulative Shipped Maintenance	57
Resetting Cumulative Quantities	57
Adjusting Prices with Retrobills	59
Setting Up Retrobilling	60
Creating Retrobills Manually	62
Creating Retrobills Automatically	65

Chapter 3 Customer Sequence Schedules.....69

Customer Sequence Schedules Overview	70
Reviewing Customer Sequence Schedules	70
Sequence Schedule Programs	71
Setting Up Customer Sequence Schedules	73
Setting Control Program Values	73
Creating Customer-Specific Defaults	75
Using Customer Sequence Schedules	76
Importing Shipping Data from External Systems	76
Modifying a Sequence Schedule Release	77
Managing Duplicate Sequence Requirements	80
Referencing Sequence Lines on Scheduled Orders	81
Updating the Required Ship Schedule	83
Including Sequences on Picklists and Pre-Shippers	86
Creating Sequenced Pre-Shippers	86
Maintaining Sequences on a Pre-Shipper/Shipper	87
Maintaining Sequences in Containers	89
Maintaining Sequences on Sales Order Shippers	89
Confirming and Unconfirming Shippers	89
Sending ASN Documents with Sequence Information	90
Posting, Exporting, and Printing Invoices	90
Removing Historical Sequence Data	91

Section 2 Supplier Schedules 93

Chapter 4 Supplier Schedules95

Introduction to Supplier Schedules	96
Schedule Order Characteristics	96
Effective Dates	97
Zero Schedules	98
Setting Up Supplier Schedules	98
Setting Control Program Values	98
Creating Supplier Calendars	99
Creating Scheduled Orders	100
Allocating Percentages for MRP	108
Processing Supplier Schedules	108
Creating a Schedule Release	109
Modifying Supplier Schedules	111
Transmitting Supplier Schedules	111
Receiving Scheduled Orders	112
PO Shipper Maintenance	114
PO Shipper Receipt	114
Purchase Order Receipts	114
PO Container Maintenance	114
Cumulative Received Maintenance	115
Resetting Cumulative Quantities	115
Deleting Supplier Scheduled Orders	116

Chapter 5 Supplier Shipping Schedules.....117

Introduction to Supplier Shipping Schedules	118
Trade Sales Supplier Shipping and Planning Schedules	118
Types of Purchase Orders	119
Supplier Schedules Example	119
Menu Listing	120
Setting Up Supplier Schedules	121
Setting Control Program Values	121
Setting Up Supplier Calendars	123
Defining Ship Delivery Time (SDT) Codes	123
Defining Scheduled Order Defaults for Specific Suppliers	124
Scheduled Orders	125
Allocating Percentages for MRP	127
Creating a Schedule Release from MRP	128
Firm and Planned Requirements	128
Requirement Bucketing	129
Quantity and Date Calculations	130

Release IDs	131
Report Options	131
Manually Updating a Schedule Release	132
Transmitting Supplier Schedules	134
Exporting Supplier Schedules	135
Printing Supplier Schedules	136
Transmitting the Release by FAX	137
Reviewing and Comparing Releases	137
Comparing Shipping to Planning Schedules	138
Comparing Schedule Releases	139
Comparing the Current Release with the Prior Release	139
Deleting and Archiving Schedules	140
Chapter 6 Supplier Milk Run	141
Introduction to Supplier Milk Runs	142
Milk Run Pickup Sheet Work Flow	143
Setting Up Supplier Milk Runs	144
Specify Control Settings	144
Define Transport Modes	144
Define Supplier Transportation Networks	146
Creating and Managing Pickup Sheets	148
Pickup Sheet Creation Process	148
Creating Pickup Sheets Automatically	149
Manually Creating or Modifying Pickup Sheets	150
Viewing Pickup Sheets	155
Printing Pickup Sheets	155
Deleting and Archiving Pickup Sheets	156
Section 3 Trade Sales	159
Chapter 7 Creating and Processing Trade Sales Orders	161
Overview of Trade Sales	162
Trade Sales Features	162
Setting Up Trade Sales	162
Setting Trade Sales Control Value	163
Setting Up Item Cross-References	164
Defining Trade Sales Suppliers for Items	164
Setting Up a Trade Sales Order	165
Setting Up EDI eCommerce	168
Processing the Trade Sales Shipment	169
Importing the ASN	170

Verifying Trade Sales Documents	171
Exporting ASNs to the Customer	172
Correcting/Returning Trade Sales Orders	173
Deleting Trade Sales Orders	173
Chapter 8 Generating and Processing Schedules.....	175
Overview of Trade Sales Schedule Processing	176
Setting Up for Schedule Processing	176
Processing the Schedules	178
Generating Customer Schedules	178
System-Created Supplier Schedules	180
Viewing Trade Sales Schedules	181
Exporting Supplier Schedules	182
Deleting Trade Sales Schedule Releases	183
Product Information Resources	185
Index.....	187

Scheduled Order Management Change Summary

The following table summarizes significant differences between this document and previous versions.

Date/Version	Description	Reference
March 2016/2016 EE	Added Supplier Milk Run chapter	page 141
March 2015/2015 EE	Rebranded for QAD 2015 EE	--
March 2014/2014 EE	Rebranded for QAD 2014 EE	--
September 2013/2013.1 EE	Rebranded for QAD 2013.1 EE	--
March 2013/2013 EE	Modified Retrobill topic to describe new auto-create method	page 59
September 2012/2012.1 EE	Rebranded for QAD 2012.1 EE	--
March 2012/2012 EE	Rebranded for QAD 2012 EE	--
September 2011/2011.1 EE	Rebranded for QAD 2011.1 EE	--

Scheduled Order Management

Scheduled Order Management includes customer and supplier schedules and optional customer sequence schedules and supplier shipping schedules. Trade sales orders are a type of customer schedule you can create with another optional module. This chapter provides a brief overview of the underlying principles of Scheduled Order Management, describes the various schedules, and describes trade sales order creation and processing.

Overview of Scheduled Order Management 2

Scheduled Order Management is a combination of processes for managing the regular exchange of information among customers and suppliers.

Customer Schedules 5

Customer schedules let you process sales orders using a set of scheduled shipment dates and quantities rather than individual sales orders.

Customer Sequence Schedules 7

The optional Customer Sequence Schedules module lets you receive and process shorter term, more detailed customer sequence schedules.

Supplier Schedules 7

Supplier schedules are cumulative, schedule-driven purchase orders with multiple line items from which releases of requirements and due dates are issued.

Supplier Shipping Schedules 8

The optional Supplier Shipping Schedules module lets you generate separate supplier planning and shipping schedules.

Trade Sales 9

Trade sales agreement are special agreements between customer, tier-one supplier, and trade sales suppliers.

Overview of Scheduled Order Management

Scheduled Order Management is a combination of processes for managing the regular exchange of information among customers and suppliers. This information is used to coordinate a customer's manufacturing activities and demand for material with a supplier's manufacturing activities and shipments of material.

Customer and Supplier Information Exchange

Information is typically transmitted in the form of schedules using electronic data interchange (EDI) to streamline the process. The way information is processed depends on whether you take the point of view of the customer or the supplier:

- As a customer, you transmit schedules to suppliers, balancing demand against what has already been received.
- As a supplier, you process schedules received from customers, balancing demand against what has already been shipped.

For customer schedules, EDI-enabling software is used to pull the releases from a customer's computer network or an e-mail address the customer has designated. The document is then imported into the system using EDI eCommerce and mapped into a customer schedule maintenance program. Purpose codes within the EDI document determine how it is processed; for example, as an add, append, delete, or test.

For supplier schedules, EDI eCommerce translates the schedule into an EDI format that can be read by the supplier's system, which is then transmitted as a flat file and imported by the supplier.

Many customers require that an advance ship notice (ASN) be communicated when a shipment is made. The system fulfills this requirement by storing the ASN information from the shipment confirm transaction in the database. EDI eCommerce then converts the ASN information to a format acceptable to the customer's electronic commerce (EC) subsystem for transmission to the customer. Some customers also require that invoices be sent via EDI; other customers do not require an invoice and pay from the ASN.

Similarly, if you require your suppliers to send an ASN, you import that information using EDI eCommerce. When an ASN is received, it creates a purchase order shipper. When the shipment itself arrives, all you need to do is confirm it and adjust quantities if needed.

See [QAD EDI eCommerce User Guide](#).

Origins of Scheduled Order Management

Scheduled Order Management has its roots in practices developed by the automotive industry to support just-in-time (JIT) manufacturing. Just-in-time methods ensure that the required quantity of material is delivered from suppliers exactly when it is needed. By having a reliable, precisely coordinated flow of goods from suppliers, a customer can maintain an uninterrupted flow of work, while maintaining minimum levels of inventory.

Companies that use Scheduled Order Management share a common profile:

- High production volume
- Long-term commitments with customers and/or suppliers

- Frequent shipments to customers and/or frequent deliveries from suppliers
- Use of electronic data interchange (EDI)

Scheduled Order Management Today

Although it originated in the automotive industry, principles of Scheduled Order Management are being applied by companies in other industries such as electronics and consumer goods. Historically, schedules in the automotive industry have been based on cumulative accounting. A total schedule quantity was determined for a period—often a year. The effect of each shipment to a customer was calculated based on a cumulative total.

However, today, many business environments use Scheduled Order Management to ship against specific requirements. For example, many original equipment manufacturers (OEMs) in the automotive industry use a schedule releasing method that does not rely on cumulative quantities.

The system fully supports noncumulative accounting requirements for customer schedules. Each scheduled order can be marked as cumulative or noncumulative. While shipments can be referenced by cumulative position, discrete pegging of shipping requirements is also supported.

Scheduled Order Management Flow

Figure 1.1 illustrates the basic flow of supply and demand between customers and suppliers.

Fig. 1.1
Scheduled Order Management Flow

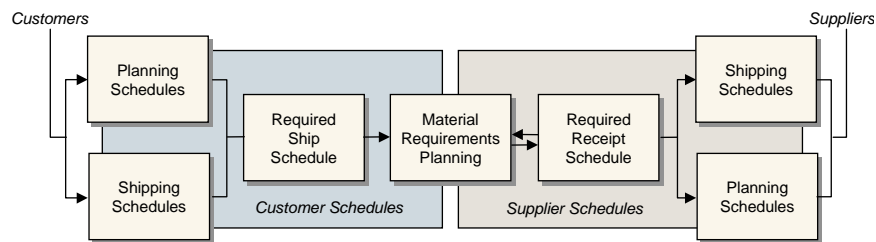

Customers send information about the items they need and when they need them as planning or shipping schedules. Based on this information, a required ship schedule is created.

When material requirements planning (MRP) is run, planned work orders and purchase orders are created to fulfill the required ship schedule. The planned purchase orders can be used to create a schedule for your suppliers, communicating your requirements to them.

Characteristics of Schedules

Customer schedules and supplier schedules represent two points of view relative to schedules. The schedules, however, have similar elements.

Shipping Schedules

Shipping schedules are used to coordinate the delivery of materials in the short term, typically one to two weeks. Demand is reported in detail, with quantities specified by date or by date and time. Shipping schedules can be updated frequently to reflect changes in production line schedules.

Planning Schedules

Planning schedules are used for moderate and long-term planning of production, materials, and resources. Demand is summarized and reported in quantities aggregated by day, week, or month. Planning schedules reflect requirements from repetitive schedules, released orders, master schedule orders, and planned orders produced by material requirements planning (MRP).

Schedule Horizons

The horizon of a planning schedule should be long enough to allow the supplier to plan materials and resources to support it. It should be longer than the cumulative lead time for the item being supplied.

Fig. 1.2
Schedule Horizons



Within a planning schedule, a customer can also define two other horizons:

- A *fabrication horizon* authorizes the supplier to proceed with the production of quantities, scheduled for delivery up to a specified date. The level of fabrication is usually below that of a finished product.
- A *raw material horizon* authorizes the purchase of raw materials to support the production of quantities that are scheduled for delivery up to a specified date.

The end of the planning schedule normally extends beyond both of these horizons.

Schedule Overlap

Shipping and planning schedules overlap for the period covered by the shipping schedule. Within this period, the two schedules may not be exactly the same, since they obtain demand from two different sources:

- The shipping schedule from production line schedules
- The planning schedule from repetitive schedules, released orders, master schedule orders, and MRP-planned orders

Fig. 1.3
Schedule Overlaps

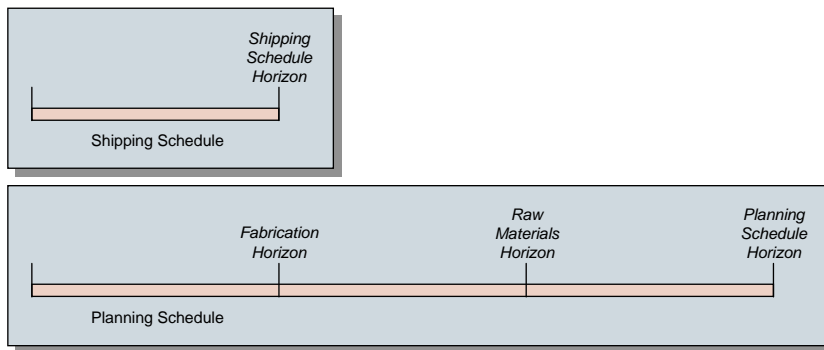

The system lets you determine which schedule should take precedence when discrepancies occur.

Updating Schedules

Shipping and planning schedules are only effective when they are accurate and up-to-date. In the automotive industry, new shipping and planning schedules are typically created for each update. Creating separate releases of each schedule ensures that it is easy to distinguish the new from the old. This reduces the potential for confusion and miscommunication.

Schedule Quantities

There are three types of schedule quantities:

- Discrete quantities are like the order quantities on standard purchase or sales orders.
- Cumulative quantities also reflect order quantities, but are a total of one or more discrete quantities. For example, a sales order has an item with an order quantity of 25 for 5 consecutive Mondays. The cumulative quantities for those lines would be 25, 50, 75, 100, and 125.
- Net quantities are similar to the quantity open for purchase and sales order lines. However, they are calculated from discrete quantities and adjusted using the cumulative quantity required less the cumulative quantity received or shipped.

Customer Schedules

Customer schedules let you process sales orders using a set of scheduled shipment dates and quantities rather than individual sales orders. Figure 1.4 illustrates the steps required to process customer schedules.

See Chapter 2, “Customer Schedules,” on page 17.

Fig. 1.4
Customer Schedule Task Flow

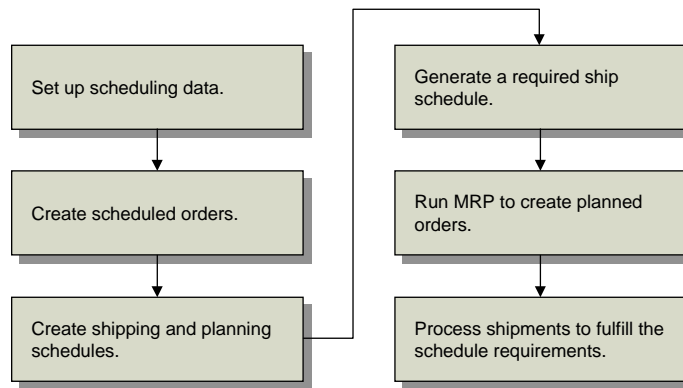

Depending on your business requirements, set up the data required to manage schedules. Typically, this includes such things as customer calendars and order periods, dock addresses, and shipping labels.

A master order determines scheduling parameters. In the short term, the customer provides day-to-day shipping requirements. These are firm commitments and override any existing plan for that period. Customers may also provide advance schedules, which are not firm orders. These are used for planning production and scheduling material.

After releases are entered as customer schedules, a required ship schedule can be calculated and the net demand passed to the Material Requirements Planning (MRP) module (23 menu).

For details, see “Running MRP” on page 51.

The system calculates due dates based on shipping lead times, calendars, and planned shipping schedules. If noncumulative schedules are being processed, requirement detail can be maintained throughout the process. During shipment, shipper lines that are tied to specific requirements are consumed. This process is known as *pegging*.

The shipper workbench streamlines the shipping process by automatically creating a shipper from a shipping picklist and allowing containerization.

Other optional modules support customer schedule functions; for example:

- You can use Customer Consignment Inventory to plan, order, ship, track, and report customer-consigned material while at the same time deferring invoicing and accounts receivable (AR) transactions. You can also have the system automatically replenish consumed amounts on the active schedule.
- You can use Logistics Accounting to track third-party transportation costs incurred when a product is shipped to your customer.

See [QAD Master Data User Guide](#).

Customer Sequence Schedules

The optional Customer Sequence Schedules module (7.5.4) lets you receive and process shorter term, more detailed customer sequence schedules. With the optional Customer Sequence Schedules module, you can set up default customer schedule details, then tailor defaults for individual customers as needed. You can also receive incoming customer sequence schedules using EDI eCommerce and maintain detailed picking records for all sequenced requirements.

Figure 1.5 shows a typical customer sequence schedule workflow in a supplier's environment.

Fig. 1.5
Customer Sequence Schedules Workflow

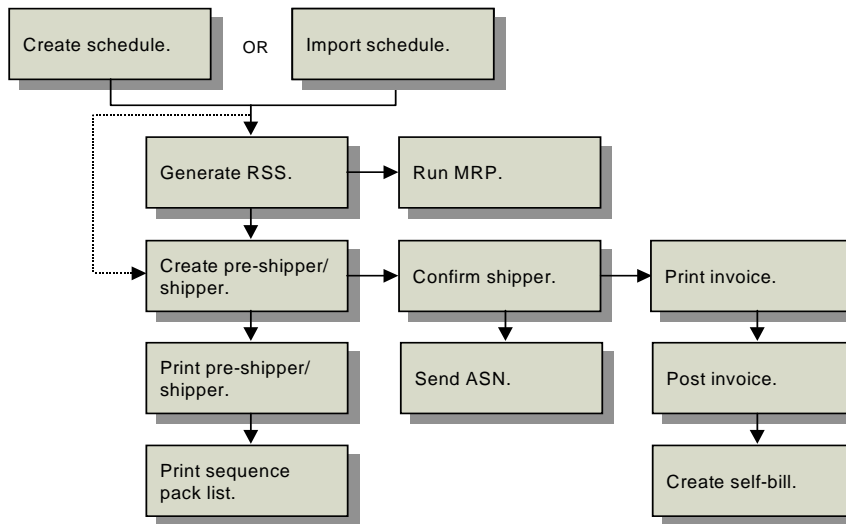

The supplier normally receives customer sequence schedules into the system using EDI eCommerce. Then, the supplier uses the sequence schedule to plan and pick material to be shipped to the customer. Using the information contained on the customer sequence schedule, the supplier packs and ships the material when the OEM needs it and in the order the OEM plans to consume it.

See *QAD EDI eCommerce User Guide*.

Supplier Schedules

Supplier schedules are cumulative, schedule-driven purchase orders with multiple line items from which releases of requirements and due dates are issued. Figure 1.6 illustrates the steps required to process supplier schedules.

See Chapter 4, “Supplier Schedules,” on page 95.

Fig. 1.6
Supplier Schedule Task Flow

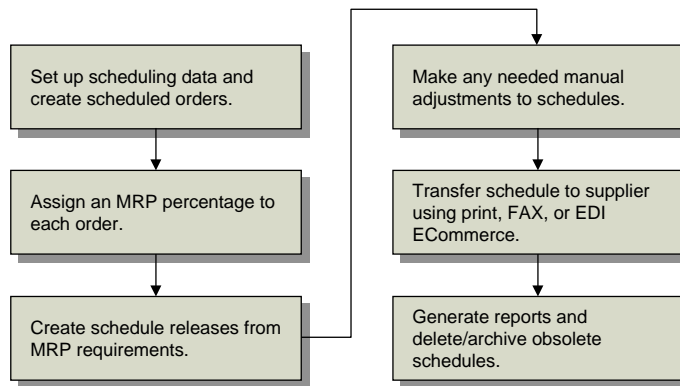

Each release has its own ID number. Send each supplier the most recent release, which replaces previous releases and becomes the active one. Net requirements are recalculated with each scheduled release and each shipment receipt.

MRP-planned purchase orders are managed with supplier schedules, where they can be edited and communicated to the supplier as schedules. You can send these schedules using EDI eCommerce. The schedules can also be printed or sent to a file that interfaces with fax software.

When you receive items, schedule quantities are updated. These quantities are reset periodically, typically at year end.

Other optional modules support supplier schedule functions; for example:

- You can use Supplier Consignment Inventory to plan, order, receive, stock, track, and report supplier-consigned material while at the same time deferring invoicing and accounts payable (AP) transactions. See [QAD Purchasing User Guide](#).
- You can use Logistics Accounting to track third-party transportation costs incurred when a product is shipped by your supplier. See [QAD Master Data User Guide](#).

Supplier Shipping Schedules

The optional Supplier Shipping Schedules module (5.5.7) lets you generate separate supplier planning and shipping schedules. You can use supplier shipping schedules and supplier planning schedules alone or in coordination with each other. They communicate requirements for multiple deliveries from a supplier who may need to adjust production to accommodate your orders.

Planning schedules are used to record weekly and monthly item requirements, while shipping schedules record daily item requirements divided into hour and minute buckets.

Companies with long-term supplier contracts that require regular weekly, daily, or even hourly deliveries typically use both planning and shipping schedules.

By themselves, planning schedules can be used in the same way standard supplier schedules are used in the system. For example, some manufacturing environments do not require the detailed bucketing features of the shipping schedule for all of their suppliers. When this is true, the planning schedule is used instead. When you generate a planning schedule without generating a corresponding shipping schedule, the planning schedule includes the daily item requirements, but without the automatic time bucketing of the shipping schedule.

Supplier shipping and planning schedules can be created manually. However, typically they are generated automatically based on item requirements from Material Requirements Planning (MRP).

Note When supplier shipping and planning schedules are updated manually, MRP is not directly affected. However, any manual changes to a shipping or planning schedule are used to automatically update the system-maintained supplier schedule (type 4). The next time MRP is run, the modified schedule data are considered by MRP.

Trade Sales

In some industries, such as the automotive industry, customers can have two levels of suppliers: tier-one suppliers and trade sales suppliers. The customer, the tier-one supplier, and trade sales suppliers can enter a unique agreement called a *trade sales* agreement.

Under a trade sales agreement, trade sales customers no longer communicate directly with trade sales suppliers. Tier-one suppliers coordinate, manage, and document the material delivery from trade sales suppliers to the customer. So, even though trade sales suppliers deliver material directly to the customer, the delivery is managed by the tier-one supplier.

Customers request that the tier-one suppliers assume responsibility for some of their suppliers in an attempt to reduce their supply base. This means that customers want to limit their contact to just the tier-one supplier and thereby reduce overhead and focus on core business processes.

From a system standpoint, trade sales suppliers are your suppliers and you transact all orders and shipping between the customer and the trade sales supplier as the tier-one supplier. So, if you purchased the optional Trade Sales module, you create a trade sales customer scheduled order. When you do, the system automatically creates supplier scheduled orders. When you receive or create active customer planning and shipping schedules, the system automatically creates supplier planning and shipping schedules. Optionally, you can also automatically export system-created supplier planning and shipping schedules to trade sales suppliers. Finally, when you import the trade sales supplier ASN, the system automatically generates the following:

- Purchase order (PO) shipper and receipt
- Sales order (SO) shipper and confirmation
- An ASN that you can optionally create and send to the customer

Trade Sales Process

To help customers manage their supply base, tier-one suppliers can provide a full range of trade sales functions from participating in the initial trade sales supplier selection to coordinating trade sales supplier production and delivery of the finished product.

Regardless of the level of your company involvement as a tier-one supplier, the general process among the trade sales supplier, tier-one supplier, and the customer consists of basic steps illustrated in Figure 1.7.

Fig. 1.7
Trade Sales Basic Process

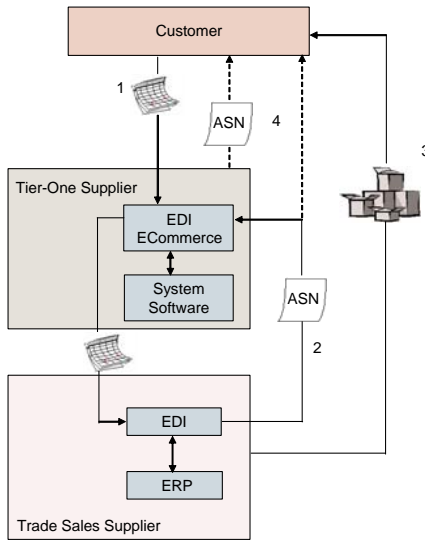

- 1 Customers electronically send customer schedule releases as EDI documents to your company. You import the customer schedules, and the system creates supplier schedules from them, then forwards supplier schedules to the trade sales supplier.
- 2 The trade sales supplier sends either a copy of or the original ASN to you. You import the ASN, and shipping and receiving documentation are created.
- 3 The trade sales supplier ships materials directly to the customer.
- 4 You optionally send an ASN to the customer.

Note Billing is described as a separate step on page 12.

The following paragraphs provide more information on each aspect of the basic process.

Schedule Releases

The customer sends schedule releases through their EDI system to you. The schedule releases can be either of the following:

- Customer planning schedules (EDI 830)
- Customer shipping schedules (EDI 862)

When you import the customer schedules into the system, the system automatically creates matching supplier schedules.

Note Supplier planning and shipping schedules are usually available only when you enable the optional Supplier Shipping Schedules module; however, trade sales functionality creates planning and shipping schedules without having to enable optional modules. See “Supplier Shipping Schedules” on page 8.

The system automatically sets the newly created supplier schedule as the active customer schedule. You can change the active customer schedule or reactivate an existing schedule of a customer trade sales order line. When you do this, the system automatically creates a new active trade sales supplier schedule.

ASN

In the second part of the process, the trade sales supplier sends an ASN to you. Trade sales suppliers typically send the original ASN directly to the customer, then send a copy of the ASN to you. Occasionally, they send the original ASN to you, then you send a copy to the customer.

When the ASN is imported into the system, the following occurs:

- 1 The system automatically creates a PO shipper for the items on the ASN.
- 2 The system automatically receives trade sales supplier items against the PO shipper.
- 3 A PO shipper receipt temporarily adds inventory to your system.
Note The system requires the temporary addition of inventory for shipping processes; however, the tier-one supplier never receives physical material.
- 4 An SO shipper is created for all the items on the original ASN.
- 5 An SO shipper confirmation issues inventory from your system.
- 6 An ASN is optionally created and sent to the customer.

Shipment

Trade sales suppliers send materials related to the ASN directly to the customer. In a trade sales process, you never receive materials intended for the customer.

Billing

As a tier-one supplier, you are responsible for billing the customer and paying the trade sales supplier. The customer sends you payment for the materials received from the trade sales supplier, then you pay the trade sales supplier. Figure 1.8 depicts the payment process in a trade sales environment.

Fig. 1.8
Trade Sales Billing

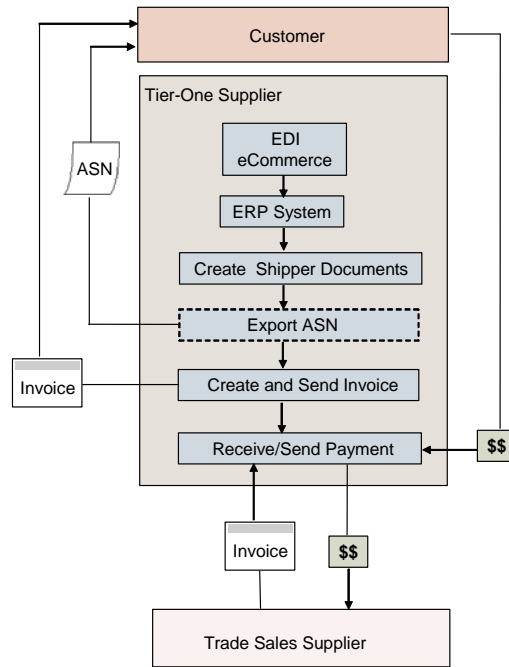

EDI eCommerce

EDI eCommerce plays an important role in trade sales by importing and exporting documents to and from trade sales customers and suppliers. The import of documents triggers the automatic generation of additional trade sales documents. Table 1.1 lists the documents that EDI eCommerce exchanges and any automatically generated documents that result from an import.

See *QAD EDI eCommerce User Guide*.

Table 1.1
Trade Sales Documents Exchanged through EDI eCommerce

Document	Sent By/Received From	Automatically Generated Document	Automatically Queue for Export?
ASN	From trade sales suppliers to you	PO shipper, PO shipper receipt, SO shipper, SO shipper confirmation, ASN	
ASN	To trades sales customer from you		Yes
Customer shipping schedule	From trade sales customer to you	Supplier shipping schedule	
Customer planning schedule	From trade sales customer to you	Supplier planning schedule	
Supplier planning schedule	To trade sales supplier from you		Yes
Supplier shipping schedule	To trade sale supplier from you		Yes

You set options in Trading Partner Parameter Maintenance (35.13.10) and eCommerce Manager (35.5 and 35.22.13) for trade sales processing.

Section 1

Customer Schedules

This section discusses the features of customer schedules and the optional customer sequence schedules.

Customer Schedules 17

Outlines the schedule task workflow and explains the system.

Customer Sequence Schedules 69

Outlines the sequence schedules workflow and gives additional information.

Customer Schedules

Customer schedules refer to the shipping and planning schedules that your customers send to you as a supplier. These schedules are used to create cumulative, schedule-driven sales orders with multiple line items. Based on scheduled orders, you release shipments using standard sales order shipping functions. Each release has its own ID number and each shipment you send to a customer has its own shipment number.

Note The QAD Document Library includes related training material. See [QAD Customer Schedules Training Guide](#).

Managing Customer Schedules 18

Describes the functions associated with customer schedule management.

Setting Up Customer Schedules 22

Outlines the schedule setup workflow and describes which data is necessary for schedule functions.

Creating Customer Scheduled Orders 31

Defines scheduled orders and describes the frames used to create them.

Processing Customer Schedules 43

Explains how schedules are loaded, imported, and processed.

Running MRP 51

Details how to run MRP to explode orders.

Processing Shipments 51

Describes how to process shipments with Sales Order Shipper Maintenance and Pre-Shipper/Shipper Confirm and covers detailed shipping requirements.

Resetting Cumulative Quantities 57

Explains how to use Cum Shipped Reset to reset cumulative quantities.

Adjusting Prices with Retrobills 59

Defines retrobilling and explains how to process, maintain, and report price adjustments.

Managing Customer Schedules

Several functions influence the outcome of customer schedules. The following paragraphs describe the functions, including the way they interact with each other when determining schedule outcome.

Using Netting Logic

A required ship schedule (RSS) identifies, for a particular customer and scheduled order, the item quantities you need to ship and the days on which you need to ship them. When you create an RSS, the system considers the customer’s shipping schedule and planning schedule along with other factors to calculate ship days and required quantities.

Because shipping schedules typically dictate shorter ship days than the planning schedule, the system contains logic that lets you specify how the system holds or *nets* the planning quantities against the shipping quantities. The Netting Logic field in the Order Line the system resolves shipping and planning schedule requirements when it creates the RSS.

See “Netting Logic” on page 42.

Netting logic determines how the system builds RSSs and the demand input to the Materials Requirements Plan (MRP).

Requirements-based users typically use netting logic option 3. Option 3 replaces the beginning of the planning schedule with the shipping schedule in each week that both planning and shipping schedules exist. Cumulative-based users typically use netting logic option 4. With option 4, the shipping schedule consumes the planning schedule in each week that both planning and shipping schedules exist.

Shipping schedule problems can arise during the last week when the shipping schedule and the planning schedule overlap; however, netting logic option 5 resolves the overlap issue. Netting logic 5 does not consider excess planning quantities in any other week other than the last overlap week. Netting logic 5 calculates the excess planning quantity in the last overlap week, compares the shop calendar to the customer calendar to determine which calendar has the shortest work week, then spreads the excess planning quantity over the remaining open work days according to the calendar with the shortest work week. This results in a more level schedule.

Example Table 2.1 provides an example of netting logic. The table depicts a four-week period. The customer sent a shipping schedule release that covers week 1 and 2. The planning schedule release covers all four weeks. The last five rows show the quantities required based on the five netting logic choices.

Table 2.1
Netting Logic Example

	Week 1				Week 2				Week 3	Week 4
Shipping Schedule	10	10	10		5	5	5			
Planning Schedule	50				40				50	40
Netting Logic 1	10	10	10		5	5	5			

Netting Logic 2	50				40				50	40	
Netting Logic 3	10	10	10		5	5	5		50	40	
Netting Logic 4	10	10	30		5	5	30		50	40	
Netting Logic 5	10	10	10		5	5	5	12	13	50	40

As shown in the table, if you specify netting logic 3, the shipping schedule takes precedence in week 1 and 2 because it overlaps the planning schedule for this period. In week 3 and 4, there is no shipping schedule requirement, so the planning schedule dictates the quantities.

If you specify netting logic 4, the shipping schedule is in place up until the last day that it is in effect. The amount on the last day is adjusted, though, to meet the consumed planning schedule.

If you specify netting logic 5, the system determines the available operating days on which to spread the excess planning quantities by selecting either the shop or customer calendar. In the example, the system used a shop calendar that is open Monday to Friday because it has the shortest work week. Week 2 is the last overlap.

See “Determining Open Days for Netting Logic” on page 19.

Determining Open Days for Netting Logic

When you specify option 5 for the Netting Logic field, the system must determine the first available open work day. An open work day is a valid business day on the selected calendar on which there are no identified shipping requirements.

The system selects the days on which to place excess planning requirements based on open work days in either the customer calendar or the shop calendar.

The system determines which calendar to add excess planning quantities by calculating the gap in days between the last shipping requirement and the first open day in both calendars. The system selects the calendar with the smallest gap since this provides the most efficient RSS. If the gap in days is equal in both calendars, the system selects the calendar that has the shortest working week.

Example The shipping schedule shows 30 quantities for the week: 10 quantities for Monday, 10 quantities for Tuesday, and 10 quantities for Wednesday. The planning schedule shows 60 quantities for the same week. This results in an excess planning quantity of 30 in the overlap week.

The shop calendar shows open days as Monday through Friday. The customer calendar shows open days as Monday through Saturday.

When you specify netting logic 5, the system compares the shop calendar to the customer calendar. Because the shop calendar has the shortest gap, the system uses it to determine open days. It then spreads the excess planning quantity of 30 over the two remaining open work days of the shop calendar. So, the last overlap week on the RSS is as follows:

Monday = 10
Tuesday = 10
Wednesday = 10
Thursday = 15
Friday = 15

If the customer calendar work days were from Monday through Thursday, the system would use the customer calendar to spread the excess planning quantity. In this case, the RSS would show the following results for the last overlap week:

Monday = 10
Tuesday = 10
Wednesday = 10
Thursday = 30

Calendar Options, RSS, and Netting Logic

When you set RSS Calendar Option to 3 (no calendars) in Container/Shipper Control (7.9.24), Customer Data Maintenance (2.1.1), and Customer Scheduled Order Maintenance (7.3.13), you indicate that the system should not adjust the initial and final RSS dates by shop or customer calendars; however, if you set netting logic to 5, the system uses a calendar or calendars to determine the days over which to spread the excess planning quantity, regardless of how you set RSS Calendar Option.

When you create the RSS, the system processes requirement due dates by considering RSS Calendar Option settings and available calendars. Netting logic routines do not manipulate the requirements and dates at this point, unless planning ship/delivery pattern (SDP) codes or requirement authorization numbers (RANs) are involved.

When netting logic routines run, the system may move planning or shipping schedule requirements and dates. To prevent the requirements from ending up on inappropriate dates, the system moves requirements to appropriate dates, using the following calendar processing to re-sort the requirements and dates:

- 1 If RSS Calendar Option is 1, RSS uses the available shop and customer calendars to move requirements so that they end up on days when both the shop and customer are open.
- 2 If RSS Calendar Option is 2, RSS uses the available customer calendar to move requirements so that they end up on days when only the customer is open.
- 3 If RSS Calendar Option is 3, the system does not place dates with any calendar. The requirements are left on the dates upon which they were entered or received.

See “Customer Calendars” on page 23.

Using PCR Quantities with Netting Logic

Open MRP requirements are based on whether you set the customer order as cumulative or required. When set to cumulative, the system uses prior cumulative required (PCR) quantities and system cumulative planned and shipped quantities to determine the open MRP requirement.

Note Cumulative-based users set Ship To Cum/Req to Cum in Customer Scheduled Order Maintenance (7.3.13), while requirements-based users set Ship to Cum/Req to Req.

The PCR quantity is the total quantity required prior to the prior cumulative date of the current release. By default, this is the last day of the previous release. Customers can send PCR quantities to you when they send schedule release information that you import into the system. You can specify the Prior Cum Date and manually enter shipping PCR, planning PCR, and RSS PCR quantities needed before the current schedule begins when you edit or create a schedule in:

- Customer Plan Schedule Maint (7.5.1)
- Customer Ship Schedule Maint (7.5.2)
- Required Ship Schedule Maint (7.5.3)

You can instruct the system to include the shipping and Planning PCR quantities as additional requirements to the current release when you create the RSS with Required Ship Schedule (7.5.5) Update or Selective Req Ship Sched Update (7.5.6). To do this, set the Use Ship/Plan PCR field in Customer Schedules Control (7.3.24) or Container/Shipper Control (7.9.24).

If cumulative-based users set netting logic to 3, they typically set Use Ship/Plan PCR to Yes. The following example depicts the RSS outcome with these settings.

Example The shipping schedule release depicts week 1 and week 2 ship dates. The planning schedule covers week 1 through week 4. The overlap week, where planning and shipping calendars must be reconciled, is week 2. A planned PCR quantity of 100 and a shipped PCR quantity of 200 exist. The quantities are shown in Table 2.2.

Table 2.2
PRC Example

	Week 1			Week 2			Week 3			Week 4		
Shop Calendar	M	Tu	W	M	Tu	W						
Shipping Schedule	10	10	10	5	5	5						
Planning Schedule	50			50			50			50		
PCR												
Planned				200								
Shipped	100											
RSS	10	10	10	5	5	5	155					

The 155 quantity adjustment on Monday of week 3 is based on:

planned quantities – ship quantities.

In the example, $155 = 300$ planned quantities – 145 shipped quantities, where:

$300 = \text{plan PCR } 200 + \text{week 1 plan } 50 + \text{week 2 plan } 50$

$145 = \text{ship PCR } 100 + \text{week 1 ship } 30 + \text{week 2 ship } 15$

The plan and ship quantities are totals from the prior cum date to the last day of the last overlap week. In the example, the prior cum date is the day before Week 1 begins.

Setting Up Customer Schedules

To use customer schedules, you must set up the same baseline data required for sales orders, including items and customers. If you plan to use shipping containers, you must also set up the container items in Item Master Maintenance (1.4.1).

Within customer schedules, a number of additional kinds of data can be set up to streamline order processing. Most setup functions are found on the Customer Schedules Setup Menu (7.3). Figure 2.1 illustrates the flow of setup tasks.

Fig. 2.1
Customer Schedules Setup Flow

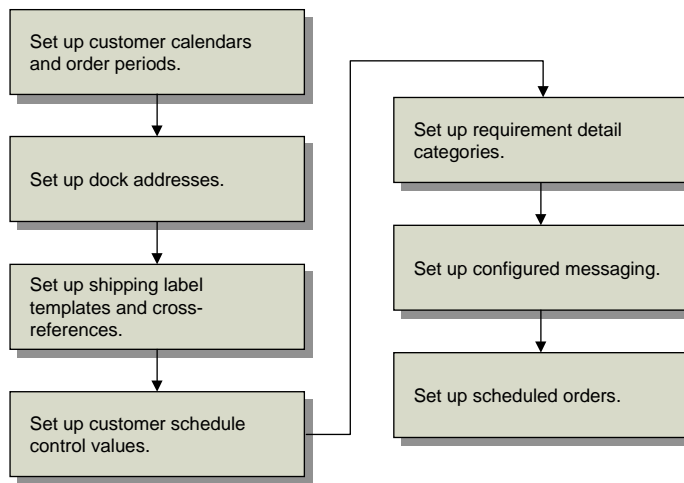

Two steps are optional:

- If you use a noncumulative accounting procedure, you also need to set up categories to use for requirement detail pegging. See page 27 for details.
- If you want to add special checks to verify shipper structure or modify how the system verifies authorization numbers, use Configured Message Maintenance (36.4.6.13) to customize the validation process. See page 30 for details.

Setting Up Schedule Data

This section covers setting up data used in other customer schedule functions:

- Customer calendars
- Customer order periods
- Customer dock addresses
- Shipping labels

Customer Calendars

When customers do not work the same days that you do, you should set up customer calendars in Customer Calendar Maintenance (7.3.1). You can create:

- A customer calendar for a standard work week and for nonworking days, such as holidays
- A default customer calendar that applies to all customers/ship-to addresses
- A customer-specific calendar

Fig. 2.2
Customer Calendar Maintenance (7.3.1)

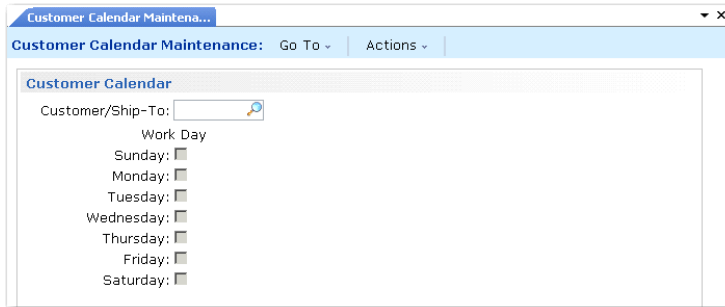

Default Calendar

To create a default customer calendar, leave the Customer/Ship-To field blank in Customer Calendar Maintenance, then specify calendar days for a default customer work week. Specify default customer exceptions in the Customer Non-Work Days frame.

Note You can still deliver to the customer when your shop floor is closed but the customer is open. To do this, set RSS Calendar Option to 2 in Supplier Scheduled Order Maintenance (5.5.1.13). See “RSS Calendar Option” on page 35.

Customer-Specific Calendar

You can also create a customer-specific or ship-to-specific calendar. You can use a calendar defined for a customer or ship-to to adjust shipment dates backward during RSS update, when the arrival date falls on a nonoperating day for that customer or ship-to. To do this, enter the code that identifies the customer or ship-to address in the Customer/Ship-To field in Customer Calendar Maintenance. Then specify Yes or No for each day of the week that is a work day for the customer. Finally, enter exceptions and holidays that override the normal work days in the Customers Non-Work Days frame.

Specifying a Customer Calendar for Required Ship Schedules

The system can use a customer calendar when it creates the required ship schedule (RSS) so that releases do not occur on nonworking days. To do this, set up customer calendars before running Required Ship Schedule Update (7.5.5) or Selective Req Ship Sched Update (7.5.6). Use the RSS Calendar Option field to specify the calendar option you want the system to use in the following programs:

- Customer Schedules Control (7.3.24) and Container/Shipper Control (7.9.24)
- Customer Data Maintenance (2.1.1)

- Customer Scheduled Order Maintenance (7.3.13)

You can modify the field at any time. RSS Calendar Option in Customer Schedules Control and Container/Shipper Control sets the field in Customer Data Maintenance. RSS Calendar Option in Customer Data Maintenance sets the field in Customer Scheduled Order Maintenance.

When you modify RSS Calendar Option in Customer Scheduled Order Maintenance (7.3.13), the system stores a value indicating the schedule has changed. When you run Required Ship Schedule Update (7.5.5) or Selective Required Ship Schedule Update (7.5.6), the system recalculates the customer's receipt quantities and dates for all schedules that have changed and uses the calendar option you specify in Customer Scheduled Order Maintenance to calculate dates.

See "RSS Calendar Option" on page 35.

If you specify 1 in the RSS Calendar Option field, the system searches for calendars in this order:

- 1 Ship-to-specific calendar
- 2 Customer-specific calendar (if the ship-to is different from the customer ID)
- 3 Default customer calendar
- 4 Site-specific shop calendar
- 5 Default shop calendar

If you specify Option 2, the system uses numbers 1 through 3 to search for customer calendars. The system makes no calendar adjustments if it cannot find a customer calendar of any type.

When you specify Option 3, you indicate that the system should not adjust the initial and final RSS dates by shop or customer calendars.

Note If you set netting logic to 5, the system uses a calendar to determine the days over which to spread the excess planning quantity, regardless of how you set RSS Calendar Option. See "Netting Logic" on page 42.

Customer Order Periods

Use Customer Order Period Maintenance (7.3.3) to set up customer order periods. You can then match your shipment planning calendar to customer order periods. For example, some trading partners develop and require you to use period numbers that correspond to specific dates.

Customer order periods are used in detail screens such as Customer Plan Schedule Maintenance (7.5.1).

Dock Addresses

Your customers may have multiple docks at a ship-to location and may specify which dock to use for a particular shipment. Assign a dock address to a ship-to customer with Dock Maintenance (7.3.6).

You must first use Business Relation Modify (36.1.4.3.2) to specify addresses with the dock address type. Only the dock addresses defined for the business relation associated with the address specified for Customer/Ship-To can be selected.

You can assign the dock address in Customer Scheduled Order Maintenance (7.3.13) as the default ship-to for the order. The dock should also be entered in Sales Order Shipper Maintenance (7.9.8) during shipment processing. Tax calculations use the ship-to site address.

See “Processing Shipments” on page 51 for details.

Shipping Labels

Shipping labels are barcode labels that you can define and print for single-item-number containers, mixed-content containers, and master containers (such as pallets) of single-item-number subcontainers. The labels enable shipments to be received with barcode readers. Labels can replace printed shipper documents used as packing lists in some supplier-customer relationships.

To implement shipping labels, you must create a shipping label template file for each type of label required for each customer. The three label types are master, mixed, and single. These templates control the data format, the bar size, printed boundary lines, and other printed information. Templates are specific to your operation, to barcode reading equipment used by your customers, and to your industry.

You can select from a wide array of barcode label design software in creating templates. Each third-party package may have different requirements for creating a template.

In addition to creating template files, you must have a barcode-capable printer. You may need to add printer-control codes in the Bar Code Control frame in Printer Setup Maintenance (36.13.2), depending on the third-party software selected. The printer codes are usually described in the printer hardware manufacturer’s documentation. Escape codes for many of the standard printer types should be provided in the documentation of the third-party barcode template design software that you choose.

Enter template values in Shipping Label Definition Maintenance (7.3.11). Each of these template values corresponds to an order field value. At print time, they are converted to barcode symbols. Table 2.3 lists template values and the field data that replaces them.

Table 2.3
Template Values

Template Value	Data Field	Entry Program
000001	Container ID	Container Workbench
000002	Shipper ID	Sales Order Shipper Maintenance
000003	Customer Item	Customer Item Maintenance
000004	Item Number	Item Master Maintenance
000005	Description	Item Master Maintenance
000006	Quantity	Container Workbench, SO Shipper Maintenance
000007	Purchase Order	Customer Scheduled Order Maintenance
000008	Supplier	Supplier Scheduled Order Maintenance
000009	Ship-From Name	Company Address Maintenance
000010	Net Weight	Item Master Maintenance
000011	Gross Weight	Item Master Maintenance
000012	Number of Sub-containers	Container Workbench
000013	UM	Item Master Maintenance
000014	Special 1 barcoded data value	Container Workbench
000015	Special 2 barcoded data value	Container Workbench
000016	Special 3 barcoded data value	Container Workbench
000017	Special 4 barcoded data value	Container Workbench
000018	Special 1 text data value	Container Workbench
000019	Special 2 text data value	Container Workbench
000020	Special 3 text data value	Container Workbench
000021	Special 4 text data value	Container Workbench

When the system sends labels to the printer, it checks the entire shipment structure. Label-related information from container and shipper maintenance must be complete and accurate. A label referencing the shipper ID is printed for each container in the shipment. The system prints:

- Master-load labels when multiple single-item-number containers are shipped in another container
- Mixed-load labels when multiple item numbers are shipped in a container
- Single-load labels when a single item number is packed in a container

When you define templates, you specify where template files are located in your file system. You also indicate the label type: mixed, master, or single.

Some customers may use their own identification number for you. If so, you must create a cross-reference between the customer's ID number for you and the system internal site so that the customer's ID number prints on the shipping label. Use Site Ship-from ID Maintenance (7.3.10) to create these cross-references. The shipping label supplier ID is printed on the shipping label by the Shipping Label Print function (7.7.7).

Setting Up Control Program Values

Customer Schedules Control (7.3.24) contains the same fields as Container/Shipper Control (7.9.24). Changing one automatically updates the other.

An additional set of control program field settings have an effect on financial transactions. These fields are also shared between customer schedules and container/shipper functions. They are described in the discussion of Cust Sched/Shipper Acct Control (36.9.7).

To ship scheduled orders, you must complete the same setup required for shipping standard sales orders. This includes defining sequence numbers using Number Range Management (NRM) features for pre-shippers, shippers, and bills of lading.

If you are using other shipping features, such as shipping groups and inventory movement codes, they must also be defined and the defaults established in the control program.

Fig. 2.3
Container/Shipper Control (7.9.24)

The screenshot shows the 'Customer Schedules Control' window with the 'Container/Shipper Control' subframe active. The fields are organized as follows:

- Next Container: 100
- Pre-Shipper Sequence ID: PRE (with a magnifying glass icon)
- Shipper Sequence ID: SHIP (with a magnifying glass icon)
- Master Bill Sequence ID: MBOL (with a magnifying glass icon)
- Shipper Document Format: GEN (with a magnifying glass icon)
- Master Bill Document Format: MB
- Max Lines on a Pre-Shipper: 15
- Shipping Label Templates:
 - Mixed Load Label: q
 - Master Load Label: q
 - Single Load Label: q
- Shipment Info For Receipts:
- Use Ship/Plan PCR:
- RSS Calendar Option: 1 (with a magnifying glass icon)
- Pre-Shipper Sequence: Pre-Shipper Sequence
- Shipper Sequence: Shipper Sequence
- Master Bill Sequence: Master Bill Sequence
- Generic Shipping Document: Generic Shipping Document
- Master Bill of Lading Format: Master Bill of Lading Format
- Automatic Cum Pegging:
- Customer Ref Is Customer Item:
- Customer/Shop: (empty field)

The fields in this control program are described in the discussion of shipping.

See *QAD Sales User Guide* for details.

Setting Up Categories for Requirement Detail

You can maintain special requirements information associated with schedules, such as:

- Special marking required by the customer for the items shipped
- Specific information needed on barcode labels for packaging
- Requirements tied to authorization numbers, such as release authorization numbers (RAN)

Multiple sets of requirement detail can be associated with each schedule detail record. This information can be updated in a subframe of Customer Plan Schedule Maint (7.5.1) and Customer Ship Schedule Maint (7.5.2).

When Required Ship Schedule Update (7.5.5) is run, requirement detail is copied to the RSS and can be viewed and maintained in Required Ship Schedule Maintenance (7.5.3). It can be reviewed on various schedule reports including:

- Schedule Inquiry (7.5.8)

- Schedule Report (7.5.10)

Requirement categories are created in Generalized Codes Maintenance (36.2.13) for field `rqm_cat`. The categories you create should be based on the type of requirement detail you receive.

See “Requirement Detail Maintenance Frame” on page 47.

The category AUTHNBR represents an authorization number. This category is created during document import, if it does not exist. AUTHNBR is the only category that has special meaning to the system. Other categories are for your reference only.

Authorization numbers are tracked from time of receipt through the entire shipment process to final invoicing. During import, if authorization numbers are received, the database is checked to verify that the numbers are unique, based on business rules.

Setting Up Configured Messages

The requirements of companies involved in long-term, scheduled relationships vary greatly. One trading partner’s requirements for how shipments are represented on an ASN may differ from another’s. Meeting the trading partner’s requirements is an important measure of supplier performance.

Configured messages let you determine the severity of various error conditions. Any shipper can be verified, whether created automatically or manually.

The verification process uses an external execution file defined in Configured Message Maintenance (36.4.6.13) to confirm that the structure and content of the shipper are valid. It also uses records defined in Configured Message Maintenance to determine the message to display if the shipper fails the verification.

See “Shipper Verification” on page 28.

Configured messaging enables you to tailor conditional error processing to meet specific business rules. You determine which conditions do not justify a message and which require an informational message, a warning message, or an error message. You can also specify the sequence in which the system checks for errors.

Different message conditions can be applied to different sites and addresses, letting you tailor processing based on the trading partner’s requirements.

Shipper Verification

Shipper verification executes automatically at the end of Shipper Gateway (7.9.22) and Picklist/Pre-Shipper–Automatic (7.9.1). Any shipper can also be verified manually using Manual SO Shipper Verification (7.9.10). This program alerts you to potential shipping problems that should be corrected before proceeding through the shipment process. To run a shipper verification, you must define an external execution file in Configured Message Maintenance (36.4.6.13) to confirm that the structure and content of the shipper are valid. Configured messaging is implemented for shippers only.

Fig. 2.4
Manual SO Shipper Verification (7.9.10)

Entries are based on the verification calling program, message number, message sequence, execution file, and severity level. You can set up messages based on language code, site, and address. Set up generic entries by leaving Site and Address blank. Define trading-partner-specific entries by entering a site code, customer ID, or ship-to code.

Sample Configured Message Files

Table 2.4 lists the five sample shipper verification programs supplied with the system, or you can specify your own. There are many other conditions you may need to verify, such as:

- All items in a container are for the same purchase order.
- All items in a container are for the same authorization number.
- All items in a container are for the same lot.
- A returnable container is correctly cross-referenced in Customer Item Maintenance (1.16).

To create your own verifications, determine which are required, write the program, attach it to a configured message entry, and verify the shipper. Multiple verifications can be run on one shipper, provided multiple configured message entries exist.

Table 2.4
Sample Configured Message Execution Files

Msg No.	Message	Calling Program	Execution File	Description
1533	Container quantity is greater than 1	rcvrfsh1.p	rcvrfc01.p	Sample container quantity verification program
1535	A ship item is not containerized	rcvrfsh1.p	rcvrfi01.p	Sample item containerization verification program
1540	A container is empty	rcvrfsh1.p	rcvrfc02.p	Sample container empty verification program
1541	Containerization is greater than 2 levels	rcvrfsh1.p	rcvrfc03.p	Sample containerization level verification program
1542	A container has two different order/line items	rcvrfsh1.p	rcvrfi02.p	Sample container has same order/line verification program

While shipper verification is optional, its use is recommended, since the process identifies initial problems with shippers. During verification, each program is executed in the order specified by the message sequence value. If any portion of the shipper is found to be invalid according to the execution file, the appropriate message displays. You can analyze and correct the situation and continue with the shipment process.

You can generate a Config Msg Verif Report (36.4.6.14), which lists the execution programs run and the sequence in which they are run. The shipper is typically used to create an ASN. Since transmission of the ASN is often time-critical, being aware of invalid shipper content or structure before shipment is vital.

Setting Up Configured Messaging

To set up configured messaging, follow these steps:

- 1 Create a user-defined verification execution program, or choose one of the five sample programs provided.
- 2 Define entries in Configured Message Maintenance. Multiple entries for the same verification program can exist, with different message sequence numbers.
- 3 Create the shipper manually using Pre-Shipper/Shipper Workbench (7.9.2) or automatically using Picklist/Pre-Shipper–Automatic (7.9.1) or Shipper Gateway (7.9.22).
- 4 If the shipper is created in Shipper Gateway or Picklist/Pre-Shipper– Automatic, verification is run automatically. Warning or error messages are displayed to the terminal or routed to a destination file name or print device.
- 5 If changes are made to the shipper or it is created in Pre-Shipper/Shipper Workbench, manually verify it using Manual SO Shipper Verification (7.9.10).
- 6 Optionally, print the Config Msg Verif Report (36.4.6.14) for a list of execution programs and the sequence in which they were run.

Configured Message Maintenance

Use Configured Message Maintenance (36.4.6.13) to create configured message entries. Make the entries specific by adding a site and address or generic by leaving site and address blank.

If Site and Address fields are blank, the verification program applies to every site, customer, and ship-to. Provide more information to make shipper verification trading-partner specific. More specific entries are used first.

Fig. 2.5
Configured Message Maintenance (36.4.6.13)

The screenshot shows a web-based form titled "Configured Message Maintenance". At the top, there is a header bar with "Configured Message Maintenance: Go To" and "Actions" menus. Below this, the form contains several input fields:

- Language ID: A dropdown menu with "US" selected and a search icon.
- Site: A text input field.
- Address: A text input field.
- Calling Program: A text input field.
- Message Number: A text input field.
- Message Sequence: A text input field.
- Execution File: A text input field.
- Severity: A text input field.
- List Type: A text input field located on the right side of the form.

Language ID. Enter a valid, active language code for selecting the appropriate message language.

Site. Optionally enter a site to be associated with the messages.

Address. Optionally enter a customer defined in Customer Create (27.20.1.1) or ship-to code defined for a customer in Customer Ship-to Create (27.20.2.1).

Calling Program. Currently, the only valid entry is `rcvrfsh1.p`, the shipper verification program.

Message Number. Enter the appropriate system message number identifying specific message text.

If you are writing your own custom Progress programs, you may want to use standard messages for consistency. These are accessed using the include file `mfmsg.i`. Pass the message number and a severity indicator, and the message displays.

Message numbers 9000 through 9900 are reserved for customer use and are not used by QAD.

Message Sequence. Enter a number indicating the order in which the execution file should be run.

Execution File. Enter the appropriate verification program. This may be one of the five sample programs supplied with the system or a custom, user-defined program. See Table 2.4 on page 29 for a list of sample programs.

Severity Level. Enter a number from 0 to 4 indicating the message severity.

0. No message displays.
1. An informational message displays.
2. A warning message displays.
3. An error message displays along with `Please re-enter`, and processing stops.
4. An error message displays, and processing stops.

Warning When verifying shippers, do not use severity level 3. Verification is a noninteractive process run after the shipper is created, without opportunity to re-enter data. Use severity level 4, which does not include `Please re-enter`.

Creating Customer Scheduled Orders

Create scheduled orders in Customer Scheduled Order Maintenance (7.3.13). A scheduled order is a combination of sales order header and trailer fields and line-item planning fields. This combination of fields provides the structure against which item quantities and dates are received.

Note Only active suppliers are available for this program.

Scheduled Order Header Frame

Some of the header fields are similar in function to the equivalent fields in Sales Order Maintenance. Important fields are discussed in this section.

See *QAD Sales User Guide* for details.

Fig. 2.6
Customer Scheduled Order Maintenance (7.3.13)

Customer Scheduled Order Maintenance (7.3.13) window showing Order Data fields. The 'Week Offset' field is set to 0 and 'Inv by Auth' is unchecked. Two lines point from these fields to a text box below the screenshot.

Use these two fields to control noncumulative schedules.

Week Offset. This field sets the weekly starting day of the scheduled order to match the customer's work week. The default is 0 (zero), which represents Monday. If this customer's business week begins on Tuesday, set this to 1, and so on through 6, which sets Sunday as the starting day. All reports and inquiries with bucketed quantities display the period requirements on this weekday.

Inv by Auth. Indicate how invoice totals should be calculated and displayed for this scheduled order.

No: Invoice totals are calculated by line. This is the typical method for calculating totals unless the customer is using AR Self-Billing.

Yes: Invoice totals are calculated by authorization number. The printed invoice includes the price and amount for each authorization line as well as the total for all authorization lines. The extended price for each invoice line item is not displayed.

This field is important for customers using the optional Self-Billing Menu (27.6.12) and ensures that rounding errors do not occur between the accounts receivable (AR) amount calculated by Self-Bill Payment Application (27.6.12.7) and the invoice amount. Rounding errors can prevent invoices from being closed or create unapplied payments.

Enter Yes if the customer on this scheduled order pays invoices using authorization numbers. When the self-payment is applied by authorization number, the amounts match exactly.

See [QAD Financials User Guide](#) for information on Self Billing.

Cumulative. Determines how requirements are entered on scheduled releases and displayed in reports and inquiries.

No: Net quantities are entered.

Yes: All quantities are entered as cumulative, meaning that the discrete quantity is added to the cumulative quantity of the previous requirement.

Consignment. Enter Yes if items on this scheduled order are consigned. This value defaults from Ship-To/Item Controls Maintenance (7.18.1), if used. If not used, the value defaults from Customer Consignment Control (7.18.24).

Enter No if the most items on this order are not consigned. You can designate individual items as consigned in the Consignment Order Line Item Data frame that displays later during order entry.

See *QAD Sales User Guide* for information on Customer Consignment Inventory.

Auto Inv Post. This field sets the default value for the Post Invoice field in Pre-Shipper/Shipper Confirm (7.9.5).

- When Post Invoice is No, invoices are not posted during shipper confirmation. You must post them manually using Invoice Post and Print (7.13.4).
- When Post Invoice is Yes, invoices are automatically posted during shipper confirmation to the general ledger Accounts Receivable (AR) account specified for the customer. You can print accumulated invoices using Invoice Print or Reprint (7.13.12).

This value defaults from the Auto Invoice Post field in Customer Schedules/Shipper Acct Control (36.9.7).

Sequenced. This field is available only when using the optional Customer Sequence Schedules (7.5.4) module. It indicates whether the scheduled order is a sequenced scheduled order. If Yes, enter sequence information in the Sequence Delivery Data frame.

This value is used by EDI eCommerce, Required Ship Schedule Update (7.5.5), and Picklist/Pre-Shipper–Automatic (7.9.1) to verify whether scheduled orders are sequenced orders. It defaults from the Scheduled Order Default field in Sequence Schedule Control (7.5.4.24).

For details, see “Sequence Detail Data Frame (7.5.4.5)” on page 79.

Note Sequenced schedules are not supported when using a trade sales arrangement; therefore, if Trade Sales is Yes, this field is display only. See Section 3, “Trade Sales,” beginning on page 159.

Dynamic UnPeg. Set to Yes to initiate dynamic de-allocation. This affects the open quantity by letting pegged requirement quantities on unconfirmed shippers for the same order line number be included in the calculation. The pegged quantities are unpegged from unconfirmed shippers and pegged to ship lines on newly created shippers.

This activity is optional. It should only be used if unconfirmed shippers are left in the system for extended periods of time.

Transport Days. Enter the number of calendar days it takes for a shipment to arrive at the customer site. Specify a value only if your customer gives you a receipt schedule, specifying the date they want the product in-house. If your customer gives you a shipping schedule, they have already factored in the transportation time.

The schedule update functions uses this to set shipment dates.

$Shipment Date = Requirement Date - Transport Days$

Trade Sales. This field enables or disables trade sales functionality.

No (the default): This is a standard scheduled order.

Yes: The system:

- Automatically creates a supplier scheduled order—a type of purchase order—for each supplier of the line items
- Sets the ship type to blank on the trade sales order

- Displays an additional Trade Sales PO Data frame at the line item level
- Prohibits you from setting the Sequenced field

If line items already exist on the order, the system prompts you to confirm that you want trade sales purchase orders created for them. Once you confirm, the system creates the trade sales supplier scheduled orders for the suppliers associated with the items in Item Master Maintenance (1.4.1). If a valid supplier is not associated with the item on the order, an error displays and you cannot continue. If any existing lines have existing schedules or if you received items for a line, an error displays and you cannot continue.

If line items do not exist, the system creates a new supplier scheduled order line as you enter new line items.

If the trade sales order has more than one item supplied by the same supplier, the system creates one supplier scheduled order with multiple lines for the items; however, if the trade sales order has multiple order lines with the same item number and the same supplier, the system creates multiple supplier scheduled orders for one supplier.

See “Supplier Schedules” on page 93.

Customer Ref is Customer Item. Indicate whether the value entered in Customer Ref should be a valid customer item, defined in Customer Item Maintenance (1.16).

The effect of setting this field to Yes varies depending on what you enter in the Item field in Customer Scheduled Order Maintenance:

- When you specify a customer item number defined in Customer Item Maintenance in the Item field, that customer item number defaults to the Customer Ref and Customer Item field (in the Order Line Item Data frame). The system replaces the value you enter in the Item field with the corresponding internal item number and displays a message to inform you of the change.
- When you enter an item defined in Item Master Maintenance in the Item field and that internal item corresponds to just one customer item, the corresponding customer item number defaults to Customer Ref and Customer Item.
- When you enter a valid internal item number in the Item field that does not have a corresponding customer item number an error displays. You must change the item or set up a customer item cross-reference in Customer Item Maintenance.
- When you enter a valid internal item number in the Item field that has more than one customer item number, no default displays in the Customer Ref field. You must specify a valid customer item in Customer Ref to continue.
- When you leave the Item field blank and enter a valid customer item in the Customer Ref field, the system enters the corresponding internal item number in the Item field and defaults the value in Customer Ref to the Customer Item field.

Setting this field to No has the following effects:

- When you enter a valid customer item in the Item field, that customer item number defaults to the Customer Item field. The system replaces the value you enter in the Item field with the corresponding internal item number and displays a message to inform you of the change. The customer item number displays next to the Customer Ref field, but the Customer Ref field is not updated.
- When you enter a valid internal item number that corresponds to just one customer item in the Item field, the corresponding customer item displays next to the Customer Ref field and defaults to the Customer Item field; Customer Ref is not updated.

- When you enter an item number that either does not have a corresponding customer item number or has more than one customer item number, then both Customer Item and Customer Ref are left blank. Values entered in Customer Ref are not validated.

This value defaults from Customer Schedules Control (7.3.24).

Print Invoice History. Specify whether an invoice history can be printed for this scheduled order using Invoice Print or Reprint (7.13.12). This lets you print a paper copy of an invoice after an EDI invoice is transmitted electronically or when the advance ship notice (ASN) is used by the customer as the invoice.

EDI Invoice History. Specify whether an invoice for this scheduled order can be selected for export to the customer in EDI format using Invoice Export (35.4.3). On new orders, this field defaults from the Send EDI Invoices parameter specified for the customer in Trading Partner Parameter Maintenance (35.13.10). If that parameter is not specified, the default is No.

Print Pack List. Indicate whether a packing list for this order should be printed.

No (the default): Do not print a packing list for this order.

Yes: Allow Sales Order Packing List to print the packing list.

Other factors such as confirmation, partial shipment, and allocation quantity can also prevent a packing list from printing. In addition, only sales orders with a blank action status are considered. Any other action status indicates that the order is on hold. To support multi-site shipment, the system does not automatically change this field after a packing list prints or after a shipment is processed. However, you cannot print a second packing list if one already exists at a specific site and the order has not shipped.

AR Site. Enter the site where the scheduled order was recorded. This can be the same as the ship-from site, but does not have to be. You can change this site for each line item.

In multisite transactions where the AR site is different from the ship-from site, you can make shipments and let a separate AR site collect the revenues. Also, the AR site can exist in a different entity or different database, or both.

Channel. Enter an optional code identifying the distribution channel through which this scheduled order originated.

Channel is used when the system searches for default accounts on this order. Alternate Sales and Sales Discount accounts can be set up in Sales Account Maintenance (1.2.17) based on product line, site, channel, and customer type.

Ship to Cum/Req. Specify Req (required) to indicate a noncumulative schedule. If Req, an additional frame displays. Specify Cum to indicate a cumulative schedule.

Enter Req to peg ship details out of sequence. Pegging occurs automatically during the creation of the shipper in:

- Picklist/Pre-Shipper–Automatic (7.9.1)
- Pre-Shipper/Shipper Workbench (7.9.2)
- Shipper Gateway (7.9.22)

For a cumulative order, you can disable automatic pegging by setting Automatic Cum Pegging to No in Container/Shipper Control (7.9.24) or Customer Schedules Control (7.3.24).

See “Pegging Requirement Detail” on page 54.

RSS Calendar Option. Enter one of the following to specify which calendar to use:

1 (the default): Use both the customer and shop (manufacturing) calendars to create the RSS.

2: Use only the customer calendar to create the RSS.

3: Use neither the customer calendar nor shop calendar. The system creates schedule dates without any calendar adjustments.

See “Customer Calendars” on page 23.

Changing this field causes the system to recalculate the customer’s receipt quantities and dates for all affected schedules when you run Required Ship Schedule Update (7.5.5) or Selective Required Ship Schedule Update (7.5.6).

See page 23.

Salesperson Frame

You can manage salespersons from the header and line in a customer scheduled order. The Salesperson frame displays in both the header and line; see Figure 2.7. Values entered in the header frame default to the line item frame.

Fig. 2.7
Customer Scheduled Order Maintenance, Salesperson Data Frame

Salesperson 1. Enter the salesperson to receive commission and quota credit for this order. To enter more than one salesperson, set Multiple to Yes. Salespersons default from the customer address. Commission percentage defaults from the salesperson record.

The header values default to each order line. In scheduled orders, you can change the salesperson as long as an uninvoiced shipment does not exist.

The first salesperson is considered the primary salesperson for report selection. Reports list other salespersons, but in most cases, you cannot select or sort using these codes.

Salesperson commission reports are based on the commission rate and sales amount (positive or negative) for order line items. Normally, commission reports are based on the gross sales amount before tax and other add-on charges. Commissions can be listed based on gross margin, but only if all line items use the same salesperson and commission rates.

You can review commissions at the time of booking, shipment, or payment. Sales summaries and quota amounts reviewed using sales analysis functions are updated by Invoice Post and Print.

Multiple. Indicate whether you can enter more than one salesperson:

No (the default): Only one salesperson is associated with this order.

Yes: You can enter up to four salesperson codes in a pop-up frame that displays after you click Next.

Commission 1. Enter the commission percentage this salesperson receives. Values default first from Salesperson Commission Detail (2.5.6) if rates have been defined for the order customer or item product line. Otherwise, they default from Salesperson Maintenance (2.5.1). The system searches in this sequence for a commission rate:

- a Salesperson, order customer, and item product line
- b Salesperson and order customer
- c Salesperson and item product line
- d Salesperson's normal commission rate as defined in Salesperson Maintenance

Non-Cumulative Quantity Accounting Data Frame

This frame displays when Ship to Cum/Req is set to Req.

Fig. 2.8

Customer Scheduled Order Maintenance, Non-Cumulative Quantity Accounting Data Frame

The screenshot shows a software interface for 'Customer Scheduled Order Maintenance'. At the top, there are fields for 'Ship-From: 10000', 'Ship-To: 4000', 'Order: SO189', and 'ABC Company'. Below this is a section titled 'Non-Cumulative Quantity Accounting Data' which contains four input fields: 'Ship Complete' (set to 0), 'Merge RSS' (checkbox), 'AUTHNBR Unique Days' (set to 0), and 'Exclude Planning Data' (checkbox).

Ship Complete. Ship Complete is used to specify what percentage of a requirement quantity must be shipped to be considered complete. If you consider a requirement satisfied when 100 percent of the requirement quantity has been shipped, set Ship Complete to 100.

To verify that a requirement with only one authorization number is shipped properly, set Ship Complete to 1. This prevents any other occurrence of an authorization number from being shipped. When the first occurrence is pegged, it satisfies the ship complete percentage, and sets open quantity to zero. If you attempt to peg the requirement quantity for a second occurrence, an error displays.

During the generation of a required ship schedule, this field determines which RSS requirements are open and should be carried to the new active schedule. If a percentage shipped is less than the Ship Complete percentage, the requirement is included in the new active RSS.

During shipment, this field determines which requirements are available for pegging in various shipper programs.

Example Set Dynamic Unpeg to No and Ship Complete to 100. Create a shipper with an item, in a box, on a pallet, with a ship quantity of 500. With an RSS requirement of 500, when you peg 500 in the Consume Required Ship Schedule Requirements frame, the open quantity is reduced to zero. This shipment is now considered complete.

AUTHNBR Unique Days. If not zero, the system verifies that duplicate authorization numbers are not reused within the time period specified.

Merge RSS. This field determines whether open requirements from existing required ship schedules (RSS) are copied to newly generated schedules. A requirement is considered open if it has not been fully shipped.

Note During the merge, the value of Ship Complete determines which requirements are open.

No: Required Ship Schedule Update (7.5.5) and Selective Required Ship Schedule Update (7.5.6) do not copy requirements from existing active schedules to new schedules.

Yes: Required Ship Schedule Update and Selective Required Ship Schedule Update copy open requirements from existing active schedules to new schedules. If Yes, enter yes or No in the Exclude Planning Data field to indicate whether to merge planning data.

Set to Yes if your trading partner does not retransmit requirements that have not yet been shipped.

Note Open requirements that are already allocated are always copied regardless of this setting.

EDI Update RSS. When both this field and Merge RSS are Yes, the system updates the required ship schedule after importing a ship schedule in Document Import (35.1).

The default is No. You can update it only when Merge RSS is Yes.

You can update the RSS using Required Ship Schedule Update (7.5.5) or Selective Req Ship Sched Update (7.5.6). However, depending on how frequently you run the import process, it is possible to miss some requirements when you do the update manually. Updating the RSS at the same time the schedule is imported and merged avoids this problem.

Exclude Planning Data. You can update this field only when Merge RSS is Yes. When open requirements are being merged, this field determines how the system manages planning data.

No: Planning data from the active required ship schedule is merged into the newly generated schedule.

Yes: Planning data from the active required ship schedule is not merged into the newly generated schedule.

Order Line Item Identification Frame

Use the following frame to identify items in the scheduled order.

Fig. 2.9

Customer Scheduled Order Maintenance, Order Line Item Identification Frame

The screenshot shows a software window titled "Customer Scheduled Order..." with a subtitle "Customer Scheduled Order Maint:". The window contains several fields and labels:

- Ship-From: 10000
- Order: SO189
- Ship-To: 4010
- Ship To: Medical Company
- Item Number: [input field]
- UM: [input field]
- PO Number: [input field]
- Customer Ref: [input field]
- Model Year: [input field]
- Line: [input field]

The following four fields uniquely identify a scheduled order detail record:

Item Number. Enter the item code for this order line. Inventory item codes must be defined previously in Item Master Maintenance (1.4.1). If you specify a customer item, the system accesses the corresponding internal item number and displays it in the Item Number field.

PO Number. Enter the customer purchase order for this line item record. You can leave this field blank.

Note You cannot specify the same item and PO number on a scheduled order for the same ship-from site and ship-to customer.

Customer Ref. The value you enter in this field depends on the value of Customer Ref is Customer Item in the scheduled order header.

If Customer Ref is Customer Item is Yes, you must provide a valid customer item number. When a customer item defaults, it corresponds to the internal item number entered in Item. Alternatively, if you enter a customer item in Item, then that customer item defaults here. Any value you enter here is validated against existing customer item numbers.

If Customer Ref is Customer Item is No, optionally enter any customer reference. This value is not validated.

See “Customer Ref is Customer Item” on page 34

Model Year. Optionally enter a model year for the scheduled order line item.

UM. Enter the unit of measure for the item. For inventory items, this defaults from the item master record.

Line. Enter the line number that uniquely identifies a scheduled sales order line item. The system assigns line item numbers automatically when you add new line items. Use this number to access and modify an existing line item.

Order Line Item Data Frame

There are two Order Line Item Data frames that display. Figure 2.10 shows the first frame; Figure 2.11 shows the second frame. Values in the first header frame specify pricing, forecast, taxing, and item location. Other critical fields are described after the Figure 2.10.

Fig. 2.10
Customer Scheduled Order Maintenance, Order Line Item Data, First Frame

The screenshot displays the 'Customer Scheduled Order Maintenance' window. At the top, it shows 'Ship-From: 10000' and 'Ship-To: 4010'. The 'Order' is identified as 'SO189' for 'Medical Company'. The selected item is 'Red Bean Bag' (Item Number: 1-bb) with a unit of measure 'EA'. The 'Order Line Item Data' section is expanded, showing pricing details: 'List Price: 2.00' and 'Net Price: 2.00'. It also includes 'Sales Account: 3000' and 'Discount Acct: 3900'. On the right side of this section, 'Consume Forecast' is checked, 'Type' is set to '100', 'Location' is '100', 'Taxable' is unchecked, and 'Category' is blank. The 'Consignment' field is also present.

Type. Indicate whether shipments of this item are to affect inventory balances. Type defaults from Memo Order Type in Item-Site Inventory Data Maintenance (1.4.16), if defined for the order line site; otherwise, it defaults from Item Master Maintenance (1.4.1). If the item is not defined, type defaults to M (memo). If Trade Sales is Yes, the system sets this field to blank.

Blank: This line item ships from inventory. When the shipment is processed, inventory balances are decreased, a general ledger (GL) transaction credits the Inventory account, and forecast is consumed.

Non-blank: This shipment does not affect inventory, does not create a GL Inventory transaction, and does not consume forecast.

While a non-blank ship type prevents the update of the Inventory account, Accounts Receivable (AR) balances are updated regardless of the ship type.

This field is validated against codes defined in Generalized Codes Maintenance (36.2.13) for field `sod_type`.

You cannot modify this field after a quantity has been shipped or invoiced.

See “Trade Sales” on page 33.

Category. Optionally specify a category associated with the order line.

Category is a generalized code that can be specified when order lines are created. Categories can group order lines based on shipping characteristics; for example rush order, special order, or replacement. Category is one of the order attributes reported by the optional Shipment Performance module.

This field is validated against values defined in Generalized Codes Maintenance (36.2.13) for field name `line_category`.

Consignment. Enter Yes if the item on this sales order line is consigned; otherwise, enter No. If Yes, you can update consignment data in a separate frame.

This value defaults from Ship-To/Item Controls Maintenance (7.18.1), if a specific control record has been defined for the combination of order ship-to and line item. Otherwise, it defaults from the order header.

Figure 2.11 shows the second Order Line Item Data frame. Critical fields are described after the figure.

Fig. 2.11
Customer Scheduled Order Maintenance, Order Line Item Data, Second Frame

Req Sched Days, Req Sched Weeks, Req Sched Months. These fields rebucket customer requirements into a sequential horizon of days, then weeks, then months.

Entering values in these fields has an impact on MRP. The weekly and monthly quantities are seen by MRP as requirements on the first day of the period, and MRP plans accordingly. This can result in excessive and unnecessary action messages.

Set these fields to zero to maintain the customer's date and quantity requirements. Also leave these fields set to zero if you are using noncumulative accounting procedures and pegging requirements through authorization numbers.

Fab Auth Days, Raw Auth Days. Raw and fabrication authorization commitments are made to give suppliers some protection against sudden and unforeseen reductions in demand.

- Raw quantity is the quantity of product the customer commits to covering component costs.
- Fab quantity is the quantity of product the customer commits to covering manufacturing costs.

These fields are used by Customer Plan Schedule Maint (7.5.1) to calculate the authorization quantities, in the event customer authorizations are for a number of days into the future.

The Schedule Report (7.5.10) shows all authorizations by release, then prints the highest of each type authorization, referencing the release ID of each. The highest of each type is determined by the highest quantity or the latest end date.

Customer Item. Enter the item number used by the customer. This number appears on ASNs and invoices in place of your internal item number. The value that displays in this field defaults from the Item field or Customer Ref field. See "Customer Ref" on page 39.

Container Item. Specify an optional container item number, used for shipping the scheduled order item. Required Ship Schedule Detail Report (7.5.14) displays this number, if defined.

You can specify Yes or No in the Alternates field to add, edit, or delete alternate containers for the container item you specify. If Yes, the Alternate Containers frame displays for input and you can add up to seven additional container items.

Charge Type. Enter the charge type to use when applying charges to this container. Define charge types in Charge Type Maintenance (7.22.1). This field defaults first from Ship-To/Container Charge Maintenance (7.22.5) if a record has been defined for the ship-to address and container item combination. Otherwise, it defaults from Container Item Maintenance (7.22.10).

Dock. Optionally, enter a valid dock address for this customer ship-to address. Items are delivered to this dock.

Start and End Effective. Optional dates controlling the introduction and duration of this line item on the order. Warning messages display for orders released before or after the effective dates.

Max Order Qty. Enter the maximum, cumulative quantity for the life of this order. When this quantity has been exceeded, the system displays warning messages at order updates, maintenance functions, inquiries, and reports.

Std Pack Qty. Enter the value used for shipping orders for this item. This field is similar to Order Multiple in the item master, but appears here because the standard shipment multiple may be different for different customers. The schedule update rounds order quantities up to this multiple. In order to preserve the scheduled order packing multiple, you must remove any order multiple specified in Item Master Maintenance (1.4.1).

Plan SDP, Ship SDP. Enter a code specifying the default ship/delivery pattern. These codes indicate the days of the week or month that shipments or deliveries are required.

SDP codes can differ for shipping and planning schedules. For instance, if planning schedules are not used, leave these fields blank to avoid any rescheduling of the planning dates while the ship schedule is rescheduled based on your shipping days.

The system uses SDP codes to calculate actual required ship dates when it updates the RSS. It preserves the planning SDP code when it adds excess planning quantities to the RSS. For example, the system places the excess quantity on Friday when you select netting logic 5 and:

- The planning SDP code stipulates Monday, Wednesday, and Friday.
- Shipping requirements exist for Monday, Tuesday, and Wednesday.
- The calendar depicts Thursday and Friday as open days.

Friday is selected for the excess even though Thursday is open because Thursday does not conform to the SDP code.

SDP codes support both the ODETTE and Automotive Industry Action Group (AIAG) ship/delivery patterns. They are translated to the appropriate industry-standard code during EDI conversion and transmission.

See “Netting Logic” on page 42.

Plan SDT, Ship SDT. Enter a code specifying the default ship/delivery time

Netting Logic. Enter one of the following codes that specify how the system uses planning and shipping schedules when it creates the RSS in Required Ship Schedule Update (7.5.5) or Selective Required Ship Schedule Update (7.5.6):

- 1: Use the shipping schedule only.
- 2: Use the planning schedule only.
- 3: Replace beginning of the planning schedule with the shipping schedule (replace logic).
- 4: Replace beginning of the planning schedule with the shipping schedule, then adjust the last quantity in each week of the shipping schedule data upward so the cumulative of the shipping schedule requirements is not less than the cumulative of the planning schedule requirements (consume logic).

For an example, see page 18.

- 5: Replace the beginning of the planning schedule with the shipping schedule. Determine the excess planning quantity in the last overlap week (the last week with both planning and shipping schedules) and spread the excess planning quantity over the open work days in the last overlap week.

See “Determining Open Days for Netting Logic” on page 19.

Cum Start. This date indicates when shipped quantities on this schedule began to accumulate. In Cumulative Shipped Maintenance, this field also displays with the label Prior Day Cum Shipped Date.

Viewing Schedule Order Information

The system supplies two ways to view schedule order information:

- Schedule Order Inquiry (7.3.14)
- Schedule Order Report (7.3.15)

To display scheduled order information, you can specify the site from which all items for the scheduled order will be shipped, customer address, item, customer reference for the item, model year, PO number, or order. Additionally, Scheduled Order Report provides a sort option for scheduled order information that displays.

Processing Customer Schedules

Once scheduled orders are set up in your system, you can receive printed or electronic schedule releases from your customers. The most recently received release normally supersedes all previous releases. An exception is raw and fabrication authorizations. The longest authorizations, calculated by end date, are the valid ones.

How a schedule is loaded also depends on the EDI purpose code specified in the header of the imported file. Based on the purpose code, schedules can be added, deleted, or simply loaded as a test without making any updates.

Two types of schedules are received: planning and shipping. The two schedule types may or may not match in quantity or due dates for any date or period. The ship schedule is usually more accurate, but this depends on your customer.

The selection of which schedule takes precedence in the short term is managed through the Netting Logic setting on the order header. Because shipping schedules typically dictate shorter ship days than the planning schedule, set the Netting Logic field to specify how the system holds or *nets* the planning quantities against the shipping quantities.

See “Netting Logic” on page 42.

There are four basic steps to processing a schedule:

- 1 Receive the schedule, usually using EDI eCommerce.
- 2 Enter the release into the system or verify the schedule received through EDI eCommerce.
- 3 Run the schedule update to create the required ship schedule.
- 4 Run MRP to explode demand and schedule component orders.

Importing Schedules with EDI eCommerce

All EDI documents are imported using the same EDI eCommerce Document Import (35.1) function. Based on control data in the EDI file, the system determines the type of document being imported, maps the data to match the appropriate system database tables and fields, and calls the appropriate gateway program to load the document into the system.

See *QAD EDI eCommerce User Guide*.

When adding a schedule, the system:

- Verifies that the trading partner exists in the system.
- Verifies that your site code matches that on the release.
- Cross-references item numbers to your internal item numbers.
- Checks and opens the order record and line number.
- Determines if quantities are discrete or cumulative based on information in the imported EDI file.
- Checks that cumulative quantities appear in ascending order.
- Deletes this specific release if it already exists in the system.
- Sets the effective end date of the prior release.
- Adds any comments and the detail schedule data.
- Creates requirement detail records if they are received. If authorization numbers are received, verifies that they are unique based on the AUTHNBR Unique Days setting in the schedule.
- Updates the cumulative requirements.
- Updates last receipt information from attached ASNs.
- Updates the fabrication and raw material authorizations.
- Creates a new schedule release, incrementing the release ID.

If the schedule import would override a required ship schedule with unshipped requirements, the transaction is not completed and an error displays.

Entering or Verifying the Release

If you do not import schedules using EDI eCommerce, enter the release into the system using Customer Plan Schedule Maintenance (7.5.1) or Customer Ship Schedule Maintenance (7.5.2). In an EDI eCommerce environment, use these programs to verify that release receipt was successful and that past customer receipts match your shipment records. The following is a brief discussion of some significant fields. This discussion focuses on Customer Plan Schedule Maintenance. Customer Ship Schedule Maintenance is almost the same. Any differences are noted.

Fig. 2.12
Customer Plan Schedule Maintenance (7.5.1)

Customer Ref. The value you enter in this field depends on the value in Customer Ref is Customer Item in Customer Schedules Control (7.3.24).

If Customer Ref is Customer Item is Yes, you must provide a valid customer item number. When a customer item defaults, it corresponds to the internal item number entered in Item. Alternatively, if you enter a customer item in Item, then that customer item defaults here. Any value you enter here is validated against existing customer item numbers.

If Customer Ref is Customer Item is No, optionally enter any customer reference. This value is not validated.

See “Customer Ref is Customer Item” on page 34.

Model Year. Enter the model year of the scheduled order line item.

Release ID. Enter a sequential number identifying this release. Planning, ship, and required schedules for the same customer schedule line item can share release IDs. Pressing Go in this field selects the active release. You can enter and make active any other release.

Ship/Deliv Pattern. Enter the ship/delivery pattern that the customer used in creating this release. Your order header takes precedence over the customer’s SDP code.

Ship/Deliv Time. Specify the code indicating the time of day when shipments or deliveries are accepted.

Int and Ext Purpose Code. These fields are not currently used. Their values have no effect on processing.

Prior Cum Req. The total customer receipts on this scheduled order up to the Prior Cum Date. This is automatically incremented by new releases from the customer based on the customer’s record of received quantities. A record of the last three or more customer receipts is often sent with each scheduled release to help identify any quantity discrepancies.

Prior Cum Date. The day before this scheduled release became active. This date is used to determine cumulative quantities. All customer receipts up to and including the prior cum date are added to the order’s cumulative total and display in the Prior Cum Req field.

Cumulative. Defaults from the scheduled order header.

Schedule Date Type. This field determines how requirement dates are calculated by Required Ship Schedule Update. Valid entries are:

Ship: Schedule dates are shipment based and requirement dates are not adjusted.

Delivery: Schedule dates are delivery based. Requirement dates are adjusted by the number of days specified for Transport Days in Customer Scheduled Order Maintenance.

The value of this field is read from the schedule when it is loaded using EDI eCommerce.

Customer Receipts

The next frame displays up to the last 10 ASNs that you sent to the customer and shows that they have been appended to the release to help maintain accurate cumulative totals.

Fig. 2.13
Customer Plan Schedule Maintenance,
Customer Receipts Frame

ASN/Shipper Nbr. The last three ASNs, or receipt documents, are typically sent by the customer with each schedule release. Each is identified with a shipper or ASN number. The ASNs were originally sent by your company to notify the customer of a shipment, and are used by the customer to verify quantities and delivery times.

If there are discrepancies between the ASN you sent and the received items, the customer changes the quantities and times accordingly, and attaches the ASN to the next schedule release for your verification.

Receipt Qty. The discrete quantity the customer received in the specified shipment.

Cum Receipt Qty. The cumulative quantity for this item, including this ASN/shipper receipt.

Schedule Detail Data Frame

In the Schedule Detail Data frame, you can view and edit the requirements sent by the customer on this release.

Fig. 2.14
Customer Plan Schedule Maintenance, Schedule Detail Data Frame

Int(erval). Indicate the interval this quantity requirement covers. Values are D (daily), W (weekly), M (monthly), Q (quarterly), H (half-yearly), Y (yearly).

Weekly intervals bucket requirements into the first day of the week, Monthly intervals bucket all requirements for the next month into the first Monday of the month.

Reference. The reference number is used by the customer to identify a specific shipment or delivery quantity. If this trading partner uses RAN numbers, they display in this field.

Q. A one-character forecast qualifier, communicated by the customer in plan and ship schedules.

This value normally defines whether the requirement quantity is firm or still in the planning stages. It can also be used for any special purpose specified by the customer communicating the schedule.

Since all quantities in a required ship schedule are firm, Required Ship Schedule Update sets this field to indicate the source of the requirement:

- 1: The requirement originated from a planning schedule.
- 2: The requirement originated from a shipping schedule.

However, if the scheduled order defines bucketing quantities and the schedule does not have any detailed requirements, the Q column still displays F after bucketing processing.

Rqm Det. Enter Yes to display an additional frame for adding or modifying requirement detail. Requirement detail is typically updated only if you are using noncumulative accounting procedures.

Requirement Detail Maintenance Frame

Figure 2.15 illustrates the Requirement Detail Maintenance frame. This frame displays when Rqm Det is Yes in the Schedule Detail Data frame.

Fig. 2.15
Customer Plan Schedule Maintenance, Requirement Detail Maintenance Frame

Category	Value
AUTHNBR	299988-0

Specify a valid category previously defined in Generalized Codes Maintenance (36.2.13) and enter the requirement detail in Value.

See “Setting Up Categories for Requirement Detail” on page 27.

If an authorization number is specified, the system verifies that it is unique, based on the setting of AUTHNBR Unique Days in the schedule.

If a requirement exists on a confirmed or unconfirmed shipper, avoid modifying the record. Doing so could result in one of the following messages:

- LINKED TO UNCONFIRMED SHIPPER
- LINKED TO CONFIRMED SHIPPER

The messages display if an entry is defined in Configured Message Maintenance with a severity level of 1 or higher.

In Required Ship Schedule Maintenance (7.5.3), the value of Reference is linked to the value for AUTHNBR. If you modify the Reference value, a new schedule detail record is created. Only one authorization number can exist for each entry in Required Ship Schedule Maint. If you attempt to add a second, an error displays.

Resource Authorization Data Frame

The Resource Authorization Data frame only displays in Customer Plan Schedule Maintenance. These fields are not updated for ship schedules.

Fig. 2.16
Customer Plan Schedule Maintenance, Resource Authorization Data Frame

The screenshot shows a software interface window titled "Customer Plan Schedule Maint". Below the title bar, there are "Go To" and "Actions" dropdown menus. The main content area is titled "Resource Authorization Data" and contains six input fields arranged in two rows and three columns:

- Row 1: Fab Qty: 0.0, Fab Start: 03/01/2007 (dropdown), Fab End: (dropdown)
- Row 2: Raw Qty: 0.0, Raw Start: 03/01/2007 (dropdown), Raw End: (dropdown)

Fab Qty, Raw Qty. The quantity of this item, in end-item terms, that the customer authorizes you to fabricate (Fab Qty) or purchase materials for (Raw Qty), as of this scheduled release. The quantity and dates are used by the Schedule Authorization Report (7.5.12), which calculates the largest fab and raw authorizations by item and order.

Fab Start/End, Raw Start/End. Start and end date for these authorizations. Some customers send dates, others quantities.

Creating a Required Ship Schedule

At any point during schedule processing, you can use Required Ship Schedule Maintenance (7.5.3) to edit the active or any other required ship schedule release. To call up the active schedule release, select the correct order and click Next. In the Release ID field, click Next again to open the active release.

You can create the RSS based on both the manufacturing and customer calendars, or to better accommodate your customer-shipping requirements, you can create the RSS based on:

- A customer/ship-to calendar only
- No calendar

See “Customer Calendars” on page 23.

To run the schedule update, use either Required Ship Schedule Update (7.5.5) or Selective Req Ship Sched Update (7.5.6). The system records the source of the requirement—either a shipping or planning schedule. This information displays in the output of the update functions.

Netting Logic Impact on RSS

The update creates a required ship schedule from either or both the planning and ship schedules. Which schedule is used depends on the Netting Logic setting in the order header.

If the order is using netting logic 3, the value of Use Ship/Plan PCR in Customer Schedules Control affects the schedule calculation.

See page 21.

If you selected netting logic 5, the system looks at the last week on the schedule where the planning and shipping schedule overlap. If your planning schedule quantity for the last overlap week exceeds the shipping schedule quantity, the system determines the days over which to spread

the excess quantity by examining both the shop and customer calendars. The system uses the calendar with the shortest days to determine open days. When you run the update, the system indicates from which schedule the requirement originates as follows:

1 = planning schedule

2 = shipping schedule

See “Netting Logic” on page 42.

Differentiating Shipping and Planning Requirements

When the system reconciles shipping and planning requirements as it creates the RSS, it also differentiates the excess planning requirements from shipping requirements on the RSS.

The system keeps track of the shipping and planning requirements by assigning and storing different internal values for the two requirement types. The following programs can set this internal value when the system creates schedule records:

- Customer Plan Schedule Maintenance (7.5.1)
- Customer Ship Schedule Maintenance (7.5.2)
- Required Ship Schedule Maintenance (7.5.3)
- Required Ship Schedule Update (7.5.5)
- Selective Req Ship Sched Update (7.5.6)
- Document Import (35.1), when importing:
 - Document 830 Planning Schedule
 - Document 862 Shipping Schedule

Optionally, you can display either or both shipping or planning requirements on RSS-related reports and inquiries.

RSS Calculations

The update first selects the most recent release for each schedule type. It then uses the order data you specify (Week Offset, Cumulative, Transport Days, Req Sched Days, Weeks and Months, Standard Pack, Netting Logic, and SDP Codes), your calendar, and your customer’s calendar to adjust, if necessary, any dates or quantities. Adjustments are required when a customer does not schedule their requirements with reference to your open days, ship schedule, or shipment multiples. All date adjustments are back-scheduled.

The program performs the following calculations:

- 1 Back-schedules for ship/delivery pattern.
- 2 Combines schedules using netting logic.
- 3 Back-schedules for customer calendar from ship/delivery schedule.
- 4 Back-schedules for transport lead time from calendar-adjusted schedule.
- 5 Revises quantities to standard pack quantity multiple.

- 6 Rebuckets quantities from month and week quantities into dates and quantities.
- 7 Creates a new active required ship schedule, assigning a Release ID and displaying quantities and dates.

Managing Requirement Detail

If you are using noncumulative accounting procedures, the system manages requirement detail based on the settings you define in the Non-Cumulative Quantity Accounting Data frame of Customer Scheduled Order Maintenance.

If requirement detail exists, the system verifies that authorization numbers are unique, based on the AUTHNBR Unique Days setting for the scheduled order. Then requirement detail is copied to the RSS and a schedule detail record is created for each requirement detail record. In addition, open requirements from the previous active RSS can be carried to the new RSS if Merge RSS is Yes.

Planning data is excluded from the merge based on the setting of Exclude Planning Data. In some environment, authorization numbers are only supplied with scheduled requirements, not planned ones.

See “Non-Cumulative Quantity Accounting Data Frame” on page 37 for details.

Merging Imported Schedules

When you import a schedule using EDI eCommerce, the system uses information from the customer’s EDI file to determine whether the incoming schedule should be merged with an existing one or replace it.

While updating the RSS also performs this function when Merge RSS is Yes in Customer Scheduled Order Maintenance (7.3.13), it is sometimes impractical to merge the schedules manually if changes are being imported several times a day.

The value of the `schedule_merge` variable in the implementation definition associated with the imported document controls whether the schedule is merged with the previous one.

- When the variable is No, the system replaces the current schedule with the corresponding new schedule from the EDI file.
- When it is Yes, requirements from the new schedule are added to those in the existing schedule.

See “Merge RSS” on page 38.

Example A schedule arrives at 10:00 a.m. with October 2 forecast for a quantity of 10. At 11:00 a.m., another schedule arrives with a new release ID for an October 3 forecast for a quantity of 2. The `schedule_merge` variable file is Yes. The system makes the second schedule the active schedule, then copies the requirements from the first schedule into it. The resulting schedule includes the requirements for both October 2 and October 3. If the second schedule had the `schedule_merge` variable set to No, the second schedule would replace the first—leaving only one requirement for a quantity of 2 on October 3.

Another variable, `detail_purpose`, can be used to provide more control over how imported forecasts are used when `schedule_merge` is Yes. Table 2.5 shows the effects of each value of the `detail_purpose` variable.

Table 2.5
Effects of Detail_Purpose Variable

Value of detail_purpose	Effect
A	For forecasts matching type, order number, line, release, date, time, firm/plan setting, and reference, the incoming amount is added to the current value.
R	The matching forecast replaces the current value.
D	The current value is set to 0 (zero).
Other value or blank	The matching forecast replaces the current value.

Report Output

When Report Detail/Summary is set to Detail in Required Ship Schedule Update, the entire calculation prints an audit trail. The update function can be run in preview mode first by setting Update to No.

When Update is Yes, a required ship schedule is created and the release ID incremented. You can rerun a schedule update by specifying the release ID of the order.

Viewing Schedule Information

The system supplies a number of reports for viewing schedule information. Each displays the source of the requirement—ship or plan schedule—received through loading EDI schedules.

- Schedule Inquiry (7.5.8)
- Schedule History Inquiry (7.5.9)
- Schedule Report (7.5.10)

Running MRP

You are now ready to run MRP to explode demand and schedule component orders.

See *QAD Manufacturing User Guide*.

Processing Shipments

Use Sales Order Shipper Maintenance (7.9.8) to specify what is going to be shipped. However, since some time may elapse between the actual shipment and the creation of the shipper, use Pre-Shipper/Shipper Confirm (7.9.5) to execute shipment.

A shipment consists of multiple items, which can be end items or containers holding other containers and/or end items. Each shipper has a unique ID, which can also be the ASN number.

Shipment maintenance relies on a structural relationship between items and containers. Containers are similar to parents and can include any number of items or other containers. A shipper is defined for the entire shipment, which contains all containers as well as any items that are not in containers.

Fig. 2.17
Scheduled Order Shipping Flow

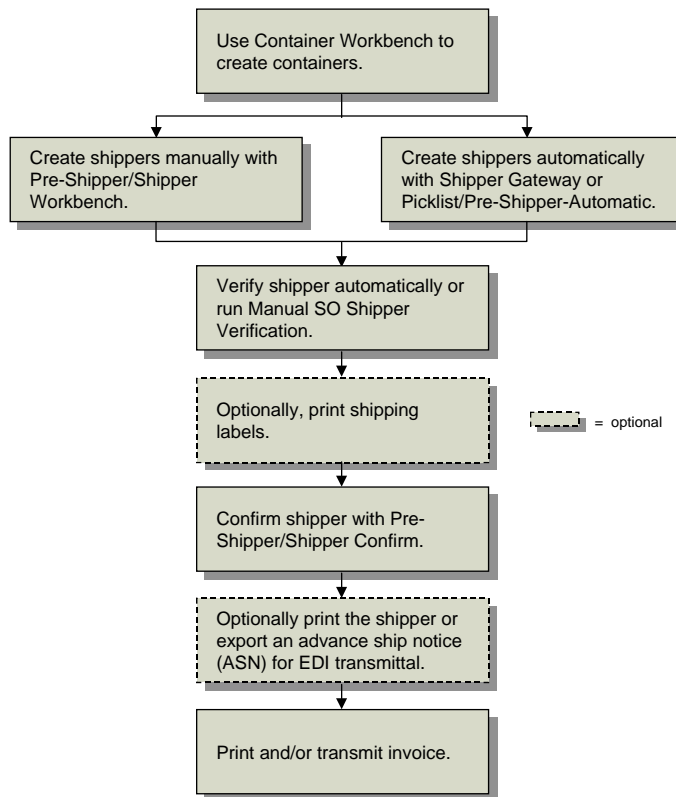

Each shipment is processed in a similar manner using the following steps. Not all steps are required.

- 1 Containerize the shipment using Container Workbench (7.7.1), or use Pre-Shipper/Shipper Workbench (7.9.2) to add items and containers to shippers directly.

You can also define the shipper using Sales Order Shipper Maintenance (7.9.8).

This step can be done without defined containers by simply assigning end items to the shipper itself. However, if you use shipping labels, items must normally be in a container.

Note Once a container is attached to a shipper or to a parent container, it cannot be deleted.

Assign containers and items, the quantities for each, then add any lot or serial detail information. You are also prompted for carrier details such as Ship Via and FOB Point. Volume and weight are not referenced.

All container and shipper data can be edited before shipper confirmation with the exception of the container ID. You can also modify shippers that have already been confirmed. However, modified shippers cannot be reconfirmed.

If you change the Ship Via or FOB Point fields on the shipper, the system does not automatically update the fields on the original scheduled order. To have the fields updated on the original scheduled order, the Post Invoice field in Pre-Shipper/Shipper Confirm (7.9.5) must be Yes.

For noncumulative schedules, requirement detail pegging takes place during this step.

See “Pegging Requirement Detail” on page 54.

If you are in multi-entry mode, you can also reedit line detail allocations for previously unconfirmed detail allocations when using multiple databases and allocating the line from a remote database.

- 2 Shipment verification is executed automatically at the completion of step 1. However, if you make additional modifications, you may want to execute Manual SO Shipper Verification (7.9.10) to reverify the structure of the shipper.

See “Setting Up Configured Messages” on page 28 for details.

- 3 Print shipping labels using Shipping Label Print (7.7.7) or SO Shipping Label Print (7.9.14). Print the labels by container. If you have referenced multiple containers under one container ID, multiple labels print. If no other containers are referenced, one label prints. Select the printer for which you have added barcode escape codes and developed template files.

- 4 Confirm the shipper using Pre-Shipper/Shipper Confirm (7.9.5).

This program confirms individual shipments by shipper ID. For noncumulative schedules, requirement detail consumption takes place during this step.

See “Consuming Requirements” on page 56.

Confirmation decrements finished goods inventory, updates GL accounts, and increases the cumulative shipped quantity. Depending on how the Post Invoice field is set, it may also post an invoice.

The value of Post Invoice initially defaults from the Auto Inv Post field in the scheduled order header.

- When Post Invoice is No, the standard procedure for processing an invoice using Invoice Post and Print (7.13.4) applies.
- When Post Invoice is Yes, Pre-Shipper/Shipper Confirm automatically posts the invoice to the customer’s AR account. You can print the invoice during shipper confirmation or later using Invoice Print or Reprint (7.13.3).

You can print formal registered fiscal shipping documents, such as a Nota Fiscal, by specifying the appropriate form code.

The effective date in Pre-Shipper/Shipper Confirm can be used to record the shipment in a specific open GL accounting period. For example, this could be used after period end when shipments for that period have not all been fully processed.

- 5 Optionally, print the shipper using Pre-Shipper/Shipper Print (7.9.4) or Sales Order Shipper Print (7.9.9).

The shipper print program creates a shipper record or packing list. This function also updates the item quantity picked. At this point, the shipment is ready to leave your shipping dock.

Note You can use Pre-Shipper/Shipper Print to include authorization numbers on the printed shipper.

- 6 Optionally, transmit the ASN using Shipment ASN Export (35.4.1).

In many scheduled order relationships, a customer does not process a shipment receipt until an ASN has been received. The ASN provides the customer with all the detail relevant to the shipment including:

- Purchase order and order line number
- Supplier and customer item numbers

- Authorization numbers, if available
- Item shipped
- Quantities
- Cumulative quantities
- Arrival time

In a trusted supplier relationship, the customer plans the shipment quantities directly into their production line, based on the electronically transmitted ASN with no receipt processing and no inspection. Often, the dock address where deliveries are made is the point on the production line where the items are going to be used, and their arrival time is coincident with the time the first item is needed for production.

Whether ASNs are sent for this particular customer is controlled by the Send EDI ASNs field in Trading Partner Parameter Maintenance (35.13.10).

- 7 Print/transmit the invoice using either Invoice Post and Print (7.13.4), Invoice Print and Reprint (7.13.12), or Invoice Export (35.4.3).

Note Authorization numbers are included on the printed invoice.

The Print Invoice History field determines whether the invoice can be selected for printing. The EDI Invoice History field, which defaults from the customer's record in Trading Partner Parameter Maintenance (35.13.10), determines whether invoices are transmitted using EDI. When invoices are neither printed nor transmitted, the customer makes payments against ASNs.

When printed invoices are permitted and the scheduled order is marked for auto-invoicing, confirming the shipper generates an invoice and then closes it. This is equivalent to the standard posting and printing steps. This enables you to make several daily or weekly shipments without requiring any specific invoicing tasks. You can print the closed invoices at the end of the day, week, or month using Invoice Print and Reprint (7.13.12).

Printing Bills of Lading

You can use Bill of Lading Print (7.9.12.1) to print a separate bill of lading for a shipment. The bill of lading is identified by the ship-from site and a code identifying the shipper record (for example, Shipper ID). Remarks entered in the Comments field of Sales Order Shipper Maintenance (7.9.8) also appear on the bill of lading.

A bill of lading shows a detailed breakdown of a shipper's content. This breakdown shows the products shipped, the total weight, and the containers used.

Pegging Requirement Detail

When noncumulative and cumulative schedules are being processed, requirement detail can be maintained throughout the process. During shipment, shipper lines that are tied to specific requirements are consumed. This process is known as *pegging*.

Pegging occurs automatically in:

- Picklist/Pre-Shipper–Automatic (7.9.1)
- Pre-Shipper/Shipper Workbench (7.9.2)
- Shipper Gateway (7.9.22)

For a cumulative schedule, you can disable automatic pegging in these three shipper programs by setting Automatic Cum Pegging to No in Container/Shipper Control (7.9.24) or Customer Schedules Control (7.3.24).

When you set Automatic Cum Pegging to No, the Consume Req field defaults to No in Pre-Shipper/Shipper Workbench (7.9.2).

Shipper Gateway

Pegging occurs during execution of Shipper Gateway, which uses an external ASCII file in the designated format to create shippers.

Fig. 2.18
Shipper Gateway (7.9.22)

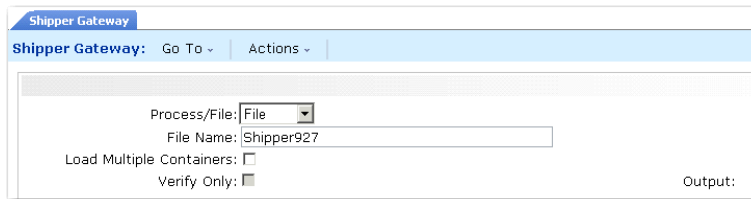

The relationship between required ship schedule lines and individual shipper lines is maintained by Shipper Gateway. As shipper lines are created and pegged, the requirement is consumed.

You can disable automatic pegging for a cumulative schedule if pegging detail is not needed.

Shipper Gateway generates a report that displays information related to pegged requirements, including requirement detail authorization numbers (Kanban).

See “Pegging Requirement Detail” on page 54.

Picklist/Pre-Shipper–Automatic

Use Picklist/Pre-Shipper–Automatic (7.9.1) to create and peg shipper lines based on the active RSS for the appropriate requirement. This program creates the shipper, adds items to it, and pegs shipper lines.

The relationship between required ship schedule (RSS) lines and individual ship lines is maintained during the shipment staging list process. As shipper lines are created and pegged, the requirement is consumed.

You can disable automatic pegging for a cumulative schedule.

The report generated at completion displays information regarding the pegged requirement, including requirement detail authorization numbers. The pegged shipper lines can be viewed and maintained in Pre-Shipper/Shipper Workbench.

When a shipper with authorization numbers is created and pegged using Picklist/Pre-Shipper–Automatic, the authorization numbers are assigned to shipper lines based on a FIFO method. You cannot designate which authorization numbers are assigned to individual shipper lines.

See “Pegging Requirement Detail” on page 54.

Pre-Shipper/Shipper Workbench

You can manually maintain the relationship between required ship schedule (RSS) requirements and individual shipper lines in Pre-Shipper/Shipper Workbench (7.9.2).

To maintain pegged shipper lines in Pre-Shipper/Shipper Workbench, set Consume Req to Yes to display the Consume Required Ship Schedule Requirements frame.

Fig. 2.19
Pre-Shipper/ Shipper Workbench (7.9.2), Consume Req Field

The screenshot shows the 'Pre-Shipper/Shipper Workbench' window. At the top, there's a header with 'Pre-Shipper/Shipper Workbench: Go To' and 'Actions'. Below that, the 'Shipper Workbench' section displays a table with columns: Order Ln, Item Number, Quantity, UM, Container, Canc B/O. A single row is visible with values: 0, Pre-Shipper: 10000/070301PS01, Ship-To: 4010. Below the table, there are several fields for order details: Sales Order, Line, Order, Quantity, UM, Site, Loc, Qty Picked, Lot/Serial, Reference, Type, Tare Weight, Consume Req (checked), ID, Gross Weight, Description, Comments, and Volume. A 'Cancel B/O' checkbox is also present.

Yes displays Consume Required Ship Schedule Requirements frame.

The Consume Required Ship Schedule Requirements frame displays, showing the RSS requirements for the scheduled order line number.

Note For a cumulative schedule, you can disable automatic pegging by setting Automatic Cum Pegging to No in Container/Shipper Control (7.9.24) or Customer Schedules Control (7.3.24). When you set Automatic Cum Pegging to No, Consume Req defaults to No.

You can modify the Ship Line Peg Qty as needed. The system adjusts the Open Qty based on the pegged quantity you enter.

Open quantity for the requirement is calculated based on:

- 1 The Ship Complete percentage in the Customer Scheduled Order Maintenance. See “Ship Complete” on page 37.
- 2 The RSS requirement quantity tied to this shipper line.
- 3 The amount pegged (the quantity placed in Ship Line Peg Qty).
- 4 Dynamic Unpeg in Customer Scheduled Order Maintenance. See “Dynamic UnPeg” on page 33.

Consuming Requirements

Requirement quantities are considered open until the shipper is confirmed in Pre-Shipper/Shipper Confirm (7.9.5). At this point, pegged quantities are transferred to shipped quantities.

During confirmation, the requirement quantity is used to increase the cumulative shipped quantity and decrease the net requirement for the order line item. Inventory is also decreased by this quantity. When Post Invoice is Yes, the invoice is automatically posted.

The confirm process also transfers pegged quantities to shipped quantities. The shipped quantities are incremented by the ship line quantity and pegged quantities are decremented by the ship line quantity.

Cumulative Shipped Maintenance

Use Cumulative Shipped Maintenance (7.5.16) to correct cumulative shipped quantities or reset the quantities on the order line item to zero, as might be done for an accounting close. This program is typically not used often, and should be restricted with menu security.

Enter the customer, PO, line item, and line number. Choose Adjust to correct a quantity problem. Choose Reset to set both cum quantities to zero.

Adjustments are typically made when an ASN is returned showing a quantity different than you shipped. If the ASN reflects the most recent shipment, adjust the Cum Shipped quantity. If another shipment has since gone out, adjust the Prior Day Cum Shipped quantity.

Adjusting quantities creates a CUM-SADJ transaction in transaction history.

Resetting Cumulative Quantities

Use Cum Shipped Reset (7.5.18) to reset the cumulative totals for scheduled orders and to generate a summary or detail report showing the updated order. You can reset one or a range of scheduled orders based on the selection criteria. This action cannot be undone.

You can run the cumulative reset function without actually resetting a scheduled order's cumulative totals. This gives you an opportunity to review the scheduled orders being reset before actually changing the database. Do this by setting Update to No. When Update is Yes, the cumulative totals are reset.

Include manual adjustments made in Cumulative Shipped Maintenance (7.5.16) by setting the Include Manual Cum Adjustments field to Yes. Setting this field to No ignores all manual adjustments when resetting the cumulative shipped quantity.

At the time you reset a scheduled order's cumulative totals, you can also enter a new cum shipped start date and time. This new date and time replaces the scheduled order's current cumulative start date and time. The time must be in 24-hour format.

When the cumulative totals are reset to zero for a date in the past, all shipments made between the specified time in the past and the current system date are totaled. This total is set as the new cumulative shipped quantity for the scheduled sales order lines.

Note Only shipments for scheduled sales order lines are included.

Fig. 2.20
Cum Shipped Reset (7.5.18)

The first half of the Cum Shipped Reset screen consists of selection criteria ranges such as ship-from, sold-to, ship-to, dock address, item number, PO number, customer ref, model year, and order. Use these values to identify the cumulative shipped quantities to reset.

Update. Enter Yes to reset the cumulative totals. Enter No to print the report without resetting cumulative totals.

Shipment/Effective Date. Enter the type of date specified in Cum Shipped Start Date.

Shipment: The value in Cum Shipped Start Date is the date when the shipment was initially entered into the system.

Effective: The value in Cum Shipped Start Date is the date when the shipment was effective for accounting purposes.

Cum Shipped Start Date. Enter the new date to start accumulating cumulative quantities for the scheduled orders.

Start Time. Enter the time when cumulative shipped reset is to occur on the specified date. The time must be entered in 24-hour format.

Include Manual Cum Adjustment. Enter Yes to include all manual adjustments in the Cum Shipped total. Enter No to ignore all manual adjustments made in Cumulative Shipped Maintenance (7.5.16).

Report Summary/Detail. Enter the format to use for this report.

Remarks. Enter any general comments.

Sort Option. Enter the sort option that determines the order the information prints on the report.

Adjusting Prices with Retrobills

Retrobilling (or retroactive billing) is the term used for a price-changing practice used in many industries, but particularly common among automotive suppliers. This practice involves reaching new pricing agreements that affect customer scheduled orders after shipment and invoice processing.

For example, retrobills are useful when:

- Commodity prices fluctuate because of price volatility for raw materials.
- Engineering changes require the customer and supplier to renegotiate part prices.
- Customers expect manufacturer productivity gains to result in downward price adjustments as quantities produced increase.
- Customers must have the parts before price negotiations are completed.

The price change and effective date are agreed upon between you and your customer. When the effective date is in the past, an invoice detailing all shipments since the effective date through the end date must be created for the incremental price difference.

Enterprise Edition provides two ways to create and process retrobills:

- Manually, using Retrobill Maintenance (7.13.13.1). This method requires you to enter a new price or adjustment amount for each line of each scheduled order that requires retrobilling. You then use Retrobill Report (7.13.13.3) to process the retrobills and create pending invoices. See “Creating Retrobills Manually” on page 62.
- Automatically, using Retrobill Auto Create (7.13.13.5). This method lets you enter ranges of criteria to select multiple orders and lines. Based on a specified scheduled order price list, the system automatically creates retrobill records and pending invoices for the adjusted amounts. Retrobill Report is required only if you choose to create the invoices later. See “Creating Retrobills Automatically” on page 65.

In either case, you then run Invoice Post and Print (7.13.4), and communicate the retrobill invoices to your customer.

Figure 2.21 summarizes the work flows for both methods.

Fig. 2.21
Retrobilling Process Map

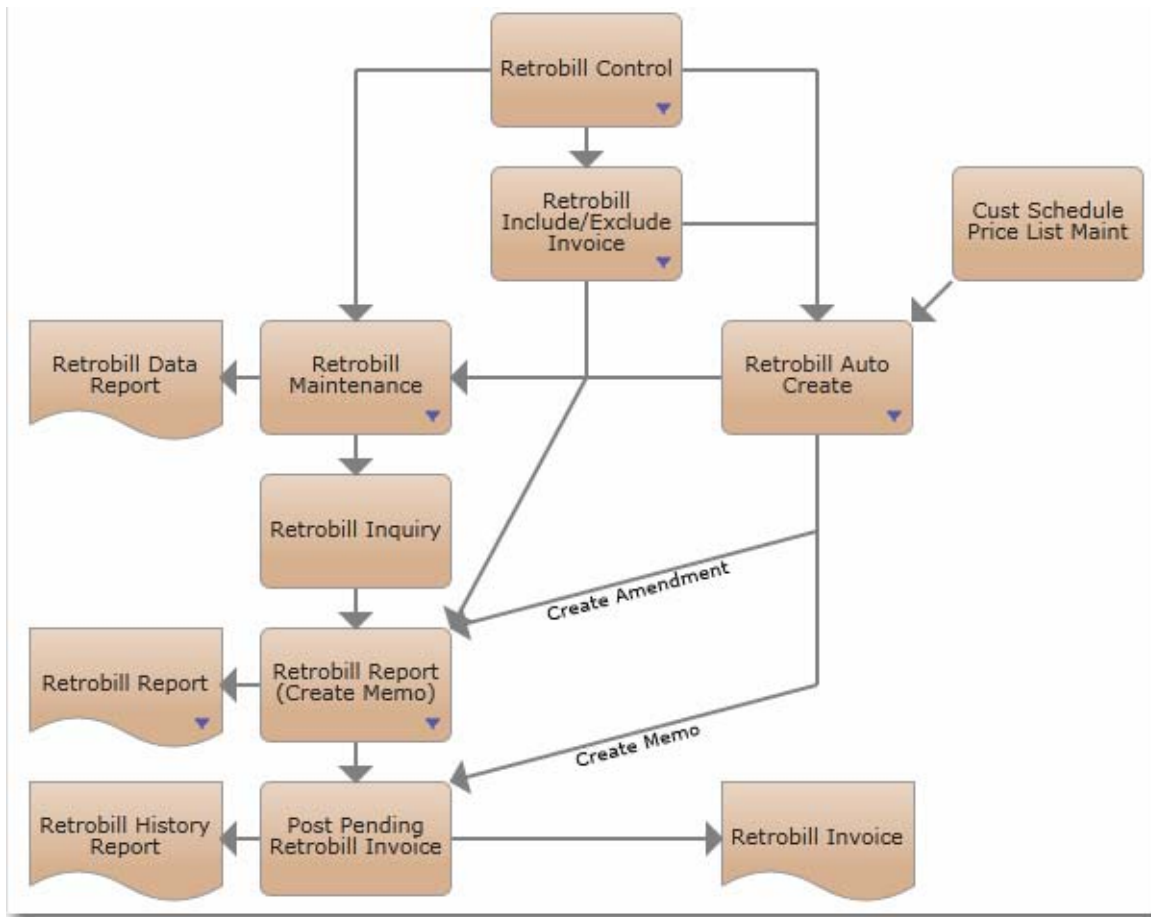

Setting Up Retrobilling

To create retrobills, perform these retrobill-specific setup tasks (in addition to creating, shipping, and invoicing customer schedules):

- Define control settings.
- If required, exclude specific invoices from retrobill processing.

Defining Control Settings

Use **Retrobill Control** (7.13.13.24) to set processing defaults and related values.

Fig. 2.22
Retrobill Control (7.13.13.24)

Amendment Sequence ID. Specify the NRM sequence, defined in Number Range Maintenance, that is used to automatically generate retrobill amendment numbers when:

- You manually create a retrobill in Retrobill Maintenance and leave the Amendment field blank.
- Retrobill Auto Create automatically generates retrobills.

The system validates that:

- The specified sequence is associated with dataset `rbm_auth`.
- The sequence definition does not exceed 16 characters.
- The Expiration Date has not been reached, if one is defined for the specified sequence ID.

See *QAD System Administration User Guide* for information on defining number range sequences.

Retrobill Price List Required. Specify the level of control that the system applies when selecting a price list in Retrobill Auto Create:

Yes: The price list specified in Retrobill Auto Create must match the specific item and UM of the invoice history record. Otherwise, the system displays an error message.

No: The system can use the price list even if the item and UM are blank.

Note Regardless of this setting, the currency must match for the price list to be selected.

Print Retrobill Invoice Detail. Indicate whether the system includes detailed retrobill information in the output of the following programs:

- Preview Invoice Print
- Invoice Post and Print
- Invoice Print or Reprint

When this field is No, printed invoices for retrobills include a limited amount of information.

When it is Yes, invoices also provide such details as the ID and amount of the previous amendment, the customer reference number, the original invoice number, and so on.

Memo Per. Specify how the system typically creates invoice lines for retrobill amendments when Create Memos is Yes in Retrobill Auto Create or Retrobill Report.

Note If Maintain Operation Type in Tax Usage is Yes in Legal Document Control (7.10.24), Create Memos does not display in those programs. Instead, the system displays Create Complementary SO and Create Credit SO.

PO: A single consolidated line is created. A separate invoice line is not created for each item retrobilled. The line item is RETROBILL; the quantity is 1.0 and the item price is the total amount retrobilled for all lines selected.

Item: A separate line item is created on the retrobill invoice for each line item entered. The line item quantity is the original quantity invoiced and the item price is the Retrobill Amount.

Inv: A separate line item is created for each invoice selected.

This field sets the default for the Memo Per field in Retrobill Auto Create and Retrobill Maintenance. You can change the value in those programs.

Note All invoice lines created are of the type Memo. These lines represent price adjustments rather than additional shipments of inventory.

Excluding Invoices from Retrobilling

Use Retrobill Include/Exclude Invoice (7.13.13.23) to prevent Retrobill Auto Create and Retrobill Report from processing specific invoices.

By default, invoices can be selected for retrobilling unless you specifically exclude them with this program.

To include a previously excluded invoice, specify selection criteria to select it, then run the program with Exclude set to No.

Fig. 2.23
Retrobill Include/Exclude Invoice (7.13.13.23)

Creating Retrobills Manually

Use the following steps to manually create a retrobill for a scheduled order line item:

- 1 Set preferences and specify a numbering sequence ID for retrobills in Retrobill Control.
- 2 As needed, use Retrobill Include/Exclude Invoices to exclude specific invoices from retrobill processing.
- 3 Create retrobills in Retrobill Maintenance. Set up the retrobill identifier and specify the scheduled order affected and the terms of the retrobill.

- 4 View retrobill information in Retrobill Inquiry (7.13.13.2).
- 5 Create a debit/credit memo with Retrobill Report.
- 6 Use Invoice Post and Print to post and optionally print the invoice.
- 7 Use Customer Invoice View (27.1.1.3) to view the invoice.
- 8 Communicate the invoice to your customer.

Retrobill Maintenance

Use Retrobill Maintenance (7.13.13.1) to create or modify retrobill records that are processed later in Retrobill Report.

Note For retrobills generated in Retrobill Auto Create, you can only perform limited functions in Retrobill Maintenance:

- Modify the values in Reason Code, Memo Per, and Comments.
- Delete the retrobill order or an amendment to a scheduled order line.

In the first frame, enter a sold-to code and amendment number; leave Amendment Number blank for a system-generated number. Those fields form the unique retrobill ID used by the system. The amendment number authorizes the retrobill and is sometimes provided by the customer.

Memo Per, which defaults from Retrobill Control (see page 61), determines how many debit/credit invoices are created.

The Reason Code and Comments fields are optional.

Click Next to move to the second frame.

The second frame consists of two sections. In the first section, identify the scheduled order and line item being changed. In the second, define the terms of the retrobill.

The ship-from, ship-to, item, PO number, scheduled order number, line item number, customer reference, and model year are used to select the scheduled order and line item being changed by the retrobill.

Click Next to advance to the lower section of the frame.

Fig. 2.24
Retrobill Maintenance (7.13.13.1)

Sold-To: 20C1000 Autoliv France SNC
Amendment Number: RB000000001

As-of Date: 1/28/2013
Reason Code:
Memo Per: PO
Comments:

Ship-From: Order: Line:
Ship-To:
Item Number: UM:
PO Number: Master Line:
Customer Ref:
Model Year:

From Ship Date: Price/Change:
To Ship Date: Amount:
Memo Invoice:

In this section, you define the terms of the retrobill by specifying:

From Ship Date/To Ship Date. These set the date range used for selecting invoices during retrobill processing in Retrobill Report. Invoices falling outside this date range are not included.

Price/Change. Indicates whether the Amount field contains a new price (Price) or a price change (Change).

Price: The value entered in the Amount field replaces the current price.

Change: The amount is applied to the current price. To reduce an existing price, enter a negative amount.

Amount. Specify the currency amount to be applied based on the Price/Change field.

Memo Invoice. Displays the debit/credit invoice number set by the Retrobill Report (7.13.13.3) when Create Memo is Yes. You can also use this field to manually enter a debit/credit invoice number.

Retrobill Report

Use Retrobill Report (7.13.13.3) to run the retrobill process. The retrobill is identified by the sold-to and amendment number (called Authorization Number here).

Use this program to process:

- Retrobills created manually in Retrobill Maintenance.
- Retrobills created automatically in Retrobill Auto Create with Create Memos set to No. In this case, the system creates pending invoices for selected existing retrobill records.

If you want to create a debit/credit invoice, set Create Memos to Yes.

Note If Maintain Operation Type in Tax Usage is Yes in Legal Document Control, Create Memos does not display. Instead, the system displays Create Complementary SO and Create Credit SO.

Note During processing, Retrobill Report uses the value of the Memo Per field specified in Retrobill Maintenance or Retrobill Auto Create to determine how debit/credit memos are created for the specific retrobill. The Create Memos field in Retrobill Report determines if a debit/credit invoice is created at all. If this field is set to No, a debit/credit invoice is *not* created regardless of how Memo Per is set. The program runs in simulation mode, producing a report for you to review before actually creating the memos.

When you use the QAD .NET UI, the Enhanced .NET Report field determines the report output format—either the same format as the character UI or the enhanced format provided by Reporting Framework.

Note If you are using the character UI, the Enhanced .NET Report field does not display.

Fig. 2.25
Retrobill Report

Creating Retrobills Automatically

Make pricing changes with automatically created retrobills using the following steps:

- 1 Set preferences and specify a numbering sequence ID for retrobills in Retrobill Control.
- 2 As needed, use Retrobill Include/Exclude Invoices to exclude specific invoices from retrobill processing.
- 3 Use Cust Schedule Price List Maint (1.10.3.1) to create or modify a list that reflects adjusted prices. See *QAD Master Data User Guide* for information on price lists.
- 4 In Retrobill Auto Create, use selection criteria to determine the invoices to have retrobills created, and specify the price list that the system uses to determine price adjustments.
- 5 Optionally, set Create Amendment to No to run the program in simulation mode. Review the effects of the selection criteria and adjust as needed before running the program in update mode.
- 6 Use the Create Memos field to determine the next step in the process:
 - If Yes, process the pending retrobill invoices using Invoice Post and Print.

- If No, create the pending invoices first in Retrobill Report before posting and printing them.

Note If Maintain Operation Type in Tax Usage is Yes in Legal Document Control, Create Memos does not display. Instead, the system displays Create Complementary SO and Create Credit SO.

- 7 Use Invoice Post and Print to post and optionally print the invoices.
- 8 Communicate retrobill invoices to customers.

Retrobill Auto Create

Use Retrobill Auto Create (7.13.13.5) to create retrobills that amend invoice lines based on the current values in a specified price list.

Based on the selection criteria, the system adjusts invoice history records to match the current prices on the specified price list.

Validations

The following fields are mandatory. They must include valid values.

- Retrobill Price List
- Currency
- Unit of Measure
- Ship Date range
- Memo Per

Note Retrobill Auto Create cannot run if any outstanding auto retrobill amendment orders require processing.

Additionally, if there are any unprocessed manual retrobill amendment orders with an effective date that is earlier than the system date, the system displays a warning message.

Skipped Records

If any of the following are true, an invoice detail record that matches the selection criteria is skipped:

- The invoice detail line is marked to be excluded from amendment in Retrobill Include/Exclude Invoice.
- The order is not a customer scheduled order.
- The sales order database is not the same as the current database.
- A matching Retrobill Price List is not found, based on the setting of Retrobill Price List Required in Retrobill Control. When that field is Yes, a price list can be used only if it matches the scheduled order line item, unit of measure, and currency.
- The user does not have access to the ship-from site.
- The ship-to does not belong to the sold-to of the order.
- The scheduled order is not effective.

Fig. 2.26
Retrobill Auto Create (7.13.13.5)

In addition to selection criteria, use the following fields to control how the system automatically creates and processes retrobills.

Reason Code. Indicates the purpose of the retrobill. Available for setup using Generalized Codes Maintenance for field `rbm_rsn`.

This field is for reference only. It appears on selected reports and inquiries.

Memo Per. Specify how the system creates pending invoice lines for retrobill amendments. This value defaults from Retrobill Control.

PO: A single consolidated line is created. A separate invoice line is not created for each item retrobilled. The line item will be RETROBILL; the quantity will be 1.0 and the item price will be the total amount retrobilled for all lines selected.

Item: A separate line item is created on the invoice for each line item entered. The line item quantity will be the original quantity invoiced and the item price will be the Retrobill Amount.

Inv: A separate line item is created for each invoice selected.

All invoice lines created are of the type Memo. These lines represent price adjustments rather than additional shipments of inventory.

Retrobill Price List. Specify a scheduled order price list to be used in determining prices for this amendment.

The Retrobill Price List must be a valid, effective customer schedule price list with the specified currency. If Retrobill Price List Required in Retrobill Control is set to Yes, the price list must have the item and UM specified.

Unit of Measure. Specify the unit of measure that applies to invoice history records to be selected for the retrobill amendment.

If Retrobill Price List Required in Retrobill Control is set to Yes, the specified Retrobill Price List must include the item and this unit of measure.

Create Amendment. Specify whether the system creates retrobills based on the selected invoice lines.

When the field is No, the program runs in simulation mode. Review the resulting report and adjust the selection criteria as needed, then run the program again with Create Amendment set to Yes.

Note When Create Amendment is Yes, the system verifies that Retrobill Control has been set up and includes a valid Amendment Sequence ID.

Show Details. Specify the amount of detail to be displayed on the output report.

Yes: The report includes complete details of each invoice history record included in the amendment.

No: The report is limited to summary information.

Create Memos. Determines whether debit/credit memos are created for the invoices selected by this retrobill.

Note If Maintain Operation Type in Tax Usage is Yes in Legal Document Control, Create Memos does not display. Instead, the system displays Create Complementary SO and Create Credit SO to support legal document requirements in some countries.

If Yes, a debit/credit memo is created. If No, a debit/credit memo is not created. In both cases, a report is generated.

When Create Memos is No, use Retrobill Report to create the pending invoice lines at a later time.

When this field is Yes, the system creates memos based on the setting of Memo Per.

Use Default Accounts. Indicate whether the system records transactions using the default account, sub-account, and cost center.

Set this field to No to display fields that let you enter account information manually.

Customer Sequence Schedules

This chapter explains how to set up and use the optional Customer Sequence Schedules module.

Note The QAD Document Library includes related training material. See [QAD Customer Sequence Schedules Training Guide](#).

Customer Sequence Schedules Overview 70

Explains the functions and purpose of the optional Customer Sequence Schedules module.

Setting Up Customer Sequence Schedules 73

Describes how to set up customer sequence schedules with program values and customer-specific defaults.

Using Customer Sequence Schedules 76

Explains how to import shipping data, modify sequence schedule releases, manage duplicate requirements, reference sequence lines in data, update ship schedules, create and maintain sequences, and export and maintain invoices.

Customer Sequence Schedules Overview

Customer shipping and planning schedules convey short-term and long-term customer requirements. The optional Customer Sequence Schedules module lets you receive and process shorter term, more detailed sequence schedules—EDI document type 866.

A sequence schedule provides a detailed, short-term view of a customer’s planned requirements. These requirements typically span no longer than a week, and are sent to you, the supplier, in the order that your customer’s manufacturing environment plans to consume them.

With the Customer Sequence Schedules module, you can:

- Set up default customer schedule details, and then tailor defaults for individual customers as needed.
- Receive incoming sequenced schedules using EDI eCommerce.
- Selectively include sequenced requirement information on:
 - Picklists
 - Pre-shippers
 - Shippers
 - Invoices
 - Advance ship notices (ASN)
 - Required ship schedules
- View variances between shipping or planning schedules and sequence schedules or between different releases of a sequence schedule.
- Generate sequence packing lists automatically when creating pre-shippers and shippers. Print sequence packing lists in forward or reverse order.
- Maintain detailed picking records for all sequenced requirements.
- Maintain multiple sequence schedule releases.

Additionally, you can use the Self-Billing module to receive payments based on the customer reference number associated with each sequence. See [QAD Financials User Guide](#).

Note Both Customer Sequence Schedules and Self-Billing are elements of the QAD PRO/PLUS functionality. Other PRO/PLUS elements include:

- Container and Line Charges; see [QAD Sales User Guide](#)
- Shipment Performance Reporting; see [QAD Sales User Guide](#)
- Supplier Performance; see [QAD Purchasing User Guide](#)
- Supplier Shipping Schedules; see Chapter 5, “Supplier Shipping Schedules,” on page 117 in this user guide

Reviewing Customer Sequence Schedules

Sequence schedules have specific characteristics.

- The schedule is typically made up of one or more days. Each day contains a sequenced list of items to be delivered.

- The schedule contains one or more items. The sample schedule in Table 3.1 contains different types of seats, by color and style. For other suppliers, such as an air-conditioner supplier with a single product, the schedule contains one item.
- Each item in the schedule is a separately orderable item and is already defined by a customer scheduled order line. Scheduled order number and line are not part of the sequence schedule transmission. The customer purchase order number is part of the transmission.
- Each sequence within the schedule contains one or more items. In Table 3.1, since a vehicle needs both front and rear seats, the schedule identifies both items as a combination by giving them the same sequence number. Notice that the vehicle identification numbers (VIN) are the same for matching sequences.
- Each item within the sequence can be delivered to different line feed locations. The schedule in Table 3.1 has two line feeds, one for the front seats (LF210) and one for the back seats (LF211). The seats are required at the same time, but must be sent to separate locations on the assembly line.
- The schedule can contain one or more exception items. The schedule in Table 3.1 has a sequence 9990, which contains a special order item. Exceptions are usually indicated in the schedule by customer-specified status codes. The exceptions are handled outside the normal sequence processing and are delivered separately.

Table 3.1
Sample Sequence Schedule

Sequence	Quantity	Item	VIN	Line Feed
1	2	red bucket seat	ABC123	LF210
1	1	red rear seat	ABC123	LF211
2	2	green bucket seat	DEF435	LF210
2	1	green rear seat	DEF435	LF211
3	1	blue bench seat	XYZ789	LF210
3	1	blue rear seat	XYZ789	LF211
4	1	green bench seat	AEG434	LF210
4	1	green rear seat	AEG434	LF211
5	2	blue bucket seat	JWZ551	LF210
5	1	blue rear seat	JWZ551	LF211
...				
499	2	green bucket seat	ZTV331	LF210
499	1	green rear seat	ZTV331	LF211
500	2	blue bucket seat	UIV331	LF210
500	1	blue rear seat	UIV331	LF211
9990	1	plaid prototype	IWV515	LAB

Sequence Schedule Programs

The optional Customer Sequence Schedules module includes the menu-level programs listed in Table 3.2.

Table 3.2
Customer Sequence Schedules Programs

Menu	Label	Program
7.5.4.1	Customer Controls Maintenance	adccmt.p
7.5.4.2	Customer Controls Inquiry	adcciq.p
7.5.4.5	Sequence Schedule Maintenance	rcsqscmt.p
7.5.4.6	Sequence Schedule Inquiry	rcsqsciq.p
7.5.4.7	Sequence Schedule Report	rcrp05.p
7.5.4.10	Sequence Pre-Shipper–Automatic	sosqsl.p
7.5.4.11	Sequence Shipper Report	rcsqrp03.p
7.5.4.13	Sequence Cross-Ref Maintenance	rcsqsxmt.p
7.5.4.14	Sequence Cross-Ref Report	rcsqsxrp.p
7.5.4.16	Sequence Schedule Variance Rpt	rcsqrp01.p
7.5.4.17	Plan/Ship Sequence Variance Rpt	rcsqrp02.p
7.5.4.22	Sequence Schedule Detail Delete	rcsqscdl.p
7.5.4.24	Sequence Schedule Control	rcsqpm.p

Customer Sequence Schedules modifies the programs listed in Table 3.3.

Table 3.3
Programs Modified by Customer Sequence Schedules

Menu	Label	Program
7.3.13	Customer Scheduled Order Maintenance	rcsomt.p
7.3.14	Scheduled Order Inquiry	rscoiq.p
7.3.15	Scheduled Order Report	rcsorp.p
7.5.5	Required Ship Schedule Update	rcrsup.p
7.5.6	Selective Required Ship Schedule Update	rcrssup.p
7.5.20	Shipment History Report	rcrp08.p
7.5.23	Schedule Delete/Archive	rcdel.p
7.7.5	SO Container Maintenance	rcctmt.p
7.9.1	Picklist/Pre-Shipper–Automatic	sososl.p
7.9.2	Pre-Shipper/Shipper Workbench	rcshwb.p
7.9.3	Pre-Shipper/Shipper Inquiry	rciq03.p
7.9.4	Pre-Shipper/Shipper Print	rcrp13.p
7.9.5	Pre-Shipper/Shipper Confirm	rcsois.p
7.9.6	Pre-Shipper/Shipper Report	rcshrp01.p
7.9.8	Sales Order Shipper Maintenance	rcshmt.p
7.9.9	Sales Order Shipper Print	rcrp11.p
7.9.15	Sales Order Shipments	sosois.p
7.9.20	Undo Shipper Number Assignment	rcslrb.p
7.9.21	Shipper Unconfirm	rcunis.p
7.9.22	Shipper Gateway	rcshgw.p
7.13.2	Pending Invoice Register	soivrp.p
7.13.3	Preview Invoice Print	sosorp10.p
7.13.4	Invoice Post and Print	soivpst.p

Menu	Label	Program
7.13.12	Invoice Print or Reprint	soivrp10.p
27.6.12.1	Self-Bill Maintenance	arsbmt.p
27.6.12.4	Self-Bill Auto Create	arsbac.p
27.6.12.10	Self-Bill Discrepancy Report	arsbrp02.p
27.6.12.13	Self-Bill Report	arsbrp.p
27.6.12.15	Shipment-Invoice Crossref Report	arsbsirp.p
35.1	Document Import	edixsnf.p
35.4.1	Shipment ASN Export	edomasn.p
35.4.3	Invoice Export	edominv.p

Setting Up Customer Sequence Schedules

With this module, you set up system-wide defaults in Sequence Schedule Control (7.5.4.24). You then use Customer Controls Maintenance (7.5.4.1) to set up customer control records for customers that should have different values than the system-wide control program values.

When you initially activate the Customer Sequence Schedules module, various programs are automatically updated to be used with this module (Table 3.3). If you deactivate Customer Sequence Schedules after you initially activate it, the modified programs function as they did before they were updated.

Setting Control Program Values

Use Sequence Schedule Control (7.5.4.24) to activate the Customer Sequence Schedules module and define general default values for all customers that use sequence schedules.

Fig. 3.1
Sequence Schedule Control (7.5.4.24)

The screenshot shows the 'Sequence Schedule Control' window with the following settings:

- Enable Sequence Schedules:
- Schedule Order Default:
- Include Seq in Req Ship Sched:
- Firm Days: 0
- Packing Order: Forward
- Sequences Per Container: 0
- Merge Schedules:
- Check Sequence Tolerance:
- Maximum Tolerance: 0
- Print Sequence Range on Shipper:
- Print Sequence Range on Invoice:
- Send Sequence with ASN:
- Send Sequence with Invoice:

Schedule Order Default sets a default value for the Sequenced field in Customer Scheduled Order Maintenance (7.3.13). All other field values in Sequence Schedule Control default to corresponding fields in Customer Controls Maintenance (7.5.4.1). You can modify the defaults you define here as needed for individual customers in Customer Controls Maintenance.

Use the following field descriptions to guide you through the control program setup.

Enable Sequence Schedules. Enter Yes to enable the Sequence Schedules module.

Schedule Order Default. Enter Yes if you typically create customer schedules with sequence information in your manufacturing environment.

The value you specify here defaults to the Sequenced field in Customer Scheduled Order Maintenance, where it determines whether the scheduled order contains sequence information. You can change it as needed for individual orders.

Include Seq in Req Ship Sched. Enter Yes to include sequence schedule data in required ship schedules (RSS).

This sets the default value for the same field in the Sequenced Delivery Data frame in Customer Scheduled Order Maintenance, unless a customer control record has already been created for the ship-to on the scheduled order. In this case, the value defaults from the customer control record.

Firm Days. Enter the number of work days from the sequence schedule that should be used to create the required ship schedule for planning purposes. This field applies only when Include Seq in RSS is Yes. This value defaults to Customer Scheduled Order Maintenance.

Enter 0 (zero), the default, to use the entire sequence schedule to generate the required ship schedule. When you specify more days than are available on the sequence schedule, the entire schedule is used.

Example One of your customers works 6-day weeks. That customer sends 8 weeks of sequenced shipping data, but you want to consider only the first 2 weeks as firm shipping requirements. In this case, you would enter 12 in the Firm Days field.

Packing Order. Indicate the order in which to print packing lists for sequenced requirements, Forward or Reverse.

Sequences Per Container. Specify the maximum number of sequences that can fit in a container. This value is used by Pre-Shipper/Shipper–Automatic and Sequence Pre-Shipper–Automatic to display breaks between multiple containers.

This value must be the default 0 (zero) or any positive number.

Example A customer uses uniform containers that can hold 10 sequences each and a pre-shipper is built containing 50 sequences. The sequence packing list will display 5 groups of 10 sequences. This is a guide to help the loading-dock worker know how many containers to pack.

Merge Schedules. Specify whether the open requirements of the currently active schedule should be combined with the new incoming schedule during EDI eCommerce document import.

This option is used when customers send future requirements to add to the current schedule but do not send existing requirements previously sent on another schedule.

Yes: The incoming schedule is combined with the currently active schedule to create a new release containing the open requirements from both schedules.

No: The incoming schedule becomes the active schedule. The open requirements from the previous release are not considered.

Check Sequence Tolerance. Enter Yes to have the system check schedule sequence numbers for gaps. Specify the size of acceptable gaps in Maximum Tolerance. The system issues a warning if it detects numbering gaps greater than the value specified.

When set to Yes, the system checks for gaps when you:

- Import a sequence schedule
- Manually add sequences to a schedule in Sequence Schedule Maintenance

Example This field is Yes and Maximum Tolerance is 2. You process a schedule with sequences 1, 2, 5, 6, 7. No warning message displays because only two numbers are missing. However, with Maximum Tolerance set to 1, the same sequence generates a warning.

Some environments use alphanumeric sequence numbers. In these cases set Check Sequence Tolerance to No because the system cannot check alphanumeric sequence range integrity. The system issues a warning whenever the value is set to Yes and an alphanumeric sequence number is processed.

Maximum Tolerance. Enter the maximum allowable size of the gap in consecutive sequence numbers on a schedule. When Check Sequence Tolerance is Yes, the system issues a warning when it detects numbering gaps greater than the value specified. When Check Sequence Tolerance is No, the system disregards this field.

Enter 0 (zero) to issue a warning whenever any gaps in sequence number are found.

Print Sequence Range on Shipper. Specify whether to print the range of sequence numbers when printing shippers. The range of sequence numbers included on the shipper prints immediately following the list of items being shipped.

Example You confirm and print a shipper that has 111 sequences. The sequences included on the shipper are sequences 1 to 10, 20, and 25 to 125. Set this value to Yes to print the following three sequence ranges on the shipper.

01 to 10

20 to 20

25 to 125

Print Sequence Range on Invoice. Specify whether to print the range of sequence numbers included on the invoice. This is the same range printed on the shipper.

Send Sequence with ASN. Specify whether sequences should be included when advanced ship notices (ASN) are transmitted using EDI eCommerce.

Send Sequence with Invoice. Specify whether sequences should be included when invoices are transmitted using EDI eCommerce.

Creating Customer-Specific Defaults

Use Customer Controls Maintenance (7.5.4.1) to create customer control records. These are customer-specific default values that are different from those specified in the control program. You normally set up customer control records when the values in the control program do not match the needed values for a specific customer.

Example The value in the control program indicates that packing lists are always printed in reverse order. However, you have a customer who requires packing lists printed in forward order. In this case, create a record in this program for this customer, indicating Forward in Packing List. When a packing list is generated for this customer, it is printed in forward order.

Fig. 3.2
Customer Controls Maintenance (7.5.4.1)

Except for Ship-To, all fields in this program are identical to the corresponding fields in the control program. All field values default from the control program. The control program values represent the system-wide settings. The settings here represent the values for the indicated ship-to only. These values default to any sequence schedules created for the ship-to address.

See “Setting Control Program Values” on page 73.

Using Customer Sequence Schedules

The Customer Sequence Schedules module can be efficiently used for just-in-time manufacturing environments, such as high-production repetitive environments. As a supplier, you can use the added sequence details to optimize planning and the sequenced shipping and delivery of your customer’s requirements.

For example, in a just-in-time manufacturing environment such as automotive manufacturing, the supplier provides seating and interior systems directly to the original equipment manufacturer (OEM). The OEM schedules the production of vehicles, including colors and options. These requirements as well as the order in which they are required, are sent to the supplier in a production sequence schedule, or 866 document.

Including sequence information on the ASN or invoice gives both the supplier and customer better visibility of the goods being shipped and received. Sequence information on the ASN or invoice can be used for self-billing purposes.

Importing Shipping Data from External Systems

Some environments use external systems to manage and maintain detailed sequence information that includes sequence numbers. When you import that information, the system looks for the corresponding sequence to pick from the internal scheduled order. If the corresponding sequence is not found, it picks the next available sequence.

You can use two methods to import sequence information into the system:

- Use Shipper Gateway (7.9.22) to import an ASCII-formatted file containing records that represent containers, pre-shippers, shippers, and sequence schedule lines. To support importing of sequence information, the format for the shipper gateway file includes fields for sequence information. See [QAD Sales User Guide](#).

- In an electronic document interchange (EDI) environment, use Document Import (35.1) in the EDI eCommerce module to import sequence schedules. See [QAD EDI eCommerce User Guide](#).

Modifying a Sequence Schedule Release

Use Sequence Schedule Maintenance (7.5.4.5) to create a new sequence schedule release or to modify an existing schedule imported using Document Import (35.1) or Shipper Gateway (7.9.22).

Use the first frame to identify the sequence schedule, including the ship- from, ship-to, and release ID. A scheduled order must already exist for the ship-from and ship-to combination. Create a new release of an existing schedule by indicating a new release ID. Enter an existing release ID to modify a schedule release already in the system.

Use the next frame to edit or enter new schedule details such as create date, packing order, and the number of sequences per container. Use the active start and active end dates to activate or deactivate the schedule release.

Fig. 3.3
Sequence Schedule Maintenance (7.5.4.5)

Release ID. Enter the sequence schedule release ID (up to 30 characters). Release ID is normally transmitted to you by the customer.

If you leave this field blank, the current active release ID is used.

When you create a new schedule release by entering a new release ID for an existing ship-from and ship-to combination, special processing occurs.

- The system prompts you to copy data from the active schedule to the new schedule.
- If you respond Yes, the system checks whether any sequences from the active release have already been picked.
- If sequences have been picked, the system prompts you to create cross-references between the sequences on the new release and the corresponding references on the active release.

If you modify an inactive schedule, the system prompts you to make that schedule active.

Active. This value indicates whether this schedule is the active schedule. There can be only one active schedule at any time for a ship-from/ship-to combination.

Cumulative. Indicate whether schedule quantities are cumulative or discrete.

No: Schedule quantities are discrete quantities. Quantity can be updated in the schedule detail.

Yes: Schedule quantities are cumulative quantities. Cum Quantity can be updated in the schedule detail.

Packing Order. Specify whether sequence packing lists for this customer ship-to should be printed in forward or reverse order on schedule reports.

Sequences Per Container. Specify the maximum number of sequences that fit in a container. This value is used by Picklist/Pre-Shipper–Automatic (7.9.1) and Sequence Pre-Shipper–Automatic (7.5.4.10) to display breaks between multiple containers.

Example A customer uses uniform containers that can hold 10 sequences each and a pre-shipper is built containing 50 sequences. The sequence packing list will display 5 groups of 10 sequences. This is a guide to help the loading-dock worker know how many containers to pack.

Check Sequence Tolerance. Enter Yes to have the system check schedule sequence numbers on this schedule for gaps. Specify the size of acceptable gaps in Maximum Tolerance. The system issues a warning if it detects numbering gaps greater than the value specified.

Example For example, this field is Yes and Maximum Tolerance is 2. You process a schedule with sequences 1, 2, 5, 6, 7. No warning message displays because only two numbers are missing. However, with Maximum Tolerance set to 1, the same sequence generates a warning.

Maximum Tolerance. Enter the maximum size of the gap in consecutive sequence numbers that is allowable for schedules associated with this customer ship-to. When Check Sequence Tolerance is Yes, the system issues a warning if it detects numbering gaps greater than the value specified. See the example above. When Check Sequence Tolerance is No, the system disregards this field.

Note Some environments use alphanumeric sequence numbers. In these cases, set Check Sequence Tolerance to No because the system cannot check alphanumeric sequence range integrity. The system issues a warning whenever the value is set to Yes and an alphanumeric sequence number is processed.

Enter 0 (zero) to issue a warning whenever any gaps in sequence number are found.

Schedule Date Type. Specify whether the dates referenced on the sequence schedule are delivery or shipment dates.

- Shipment date indicates the date when the customer's truck or delivery service will pick up the shipment from your shipping dock.
- Delivery date indicates the dates when the shipment must arrive at the customer's site or dock.

Note When setting up ship/delivery dates you should always check for manufacturing and delivery lead times. These lead times can delay delivery to the customer site. Programs that create or update the required ship schedules consider lead times when calculating ship/delivery dates.

Active Start. Enter the starting date for the schedule horizon. Active start defaults to the date the release is created. Leave this date and the active end date blank to specify that the current schedule is open. In some programs, reports, and inquiries, the active start date is for reference only and cannot be changed.

Active End. Enter the ending date for the schedule horizon. This date must be on or after the active start date. Leave this date and the active start date blank to specify that the schedule is open.

Modifying and Adding Sequences and Details

Use the Sequence Detail Data frame to edit or create new sequence records. You can also mark existing sequences as deleted. The system allows you to delete any sequence record that is not picked or cross-referenced to a picked sequence on another schedule release.

When you mark a sequence as deleted, the system makes that record inactive for the schedule. To permanently delete a sequence record from a schedule, use Sequence Schedule Detail Delete (7.5.4.22).

When you create a new schedule release by entering a new release ID in the first frame, the system prompts whether to copy data from the active schedule to the new schedule. If you accept, it checks whether any sequences from the active release have already been picked. It prompts whether to create cross-references between the sequences on the new release and the corresponding references on the active release.

You cannot pick references from the new release that are cross-referenced to sequences on the active release. These cross-referenced sequences have already consumed their requirements. Any sequences that have Deleted set to Yes are not copied to the new schedule.

Fig. 3.4
Sequence Detail Data Frame (7.5.4.5)

If you indicate that cross-references should not be created, the system copies all sequences from the active schedule to the new schedule. Any sequence records previously marked as picked or cross-referenced are reset. By resetting these sequences, the system considers them as open requirements. When you finish creating the new schedule release, the system prompts you to make the new schedule active.

Normally, sequences are not created at the supplier site. Most customer delivery sequence information is imported into the system using EDI eCommerce. Many of the fields in the Sequence Detail Data frame are used as reference by the customer and have little impact on your processing of the order.

You can optionally use the customer-defined Customer Dock and Line Feed field values as sort criteria when generating pre-shippers and shippers.

The combination of Item Number, Customer Dock, Line Feed, and Customer Reference must be unique. Customer Reference is a required field. This is the customer-assigned reference number for this sequence schedule line. For example, in the automotive industry, the customer reference is typically the Vehicle Identification Number (VIN).

The Line Item Customer Ref field is a similar field; however, you use it to enter the customer-assigned reference number for the line item. This is typically the number the customer uses to refer to the item identified by the system item number. If Customer Ref is Customer Item is Yes for the scheduled order, the line-item reference must be a valid customer number defined in Customer Item Maintenance (1.16).

See “Customer Ref” on page 39.

Reporting Sequence Schedule Information

Use the following reports to review and compare sequence schedule information:

- Use Sequence Schedule Inquiry (7.5.4.6) to display all sequences on a sequence schedule release.
- Use Sequence Schedule Report (7.5.4.7) to review a complete sequence schedule release.
- Use Sequence Schedule Variance Report (7.5.4.16) to compare two sequence schedule releases.
- Use Plan/Ship Sequence Variance Report (7.5.4.17) to compare specific item requirements on the active sequence schedule to those on the active shipping or planning schedule release.

Managing Duplicate Sequence Requirements

In some situations, the same sequence may be reported on separate schedule releases. For example, you send the last requirements of the day, but your customer creates and sends the new sequence schedule while those requirements are in transit. The new schedule will contain some of the same requirements again, since they have not arrived at the customer site.

Normally, the system automatically creates a cross-reference from the new duplicate sequence to the picked sequence when the sequence schedule is initially imported into the system. However, if the item number, customer reference, customer dock, or line feed on the new duplicate sequence does not match the picked/shipped sequence values, the cross-reference is not created.

Creating Cross-References

Use Sequence Cross-Ref Maintenance (7.5.4.13) to manually create cross-references from duplicate sequences on one schedule release to the picked/shipped sequence on another schedule release. You can also create cross-references to sequences marked as deleted, or sequences that have already been cross-referenced to previously picked/shipped sequences.

After indicating the ship-from and ship-to sites, use the selection criteria on the Picked/Shipped Sequence frame to select the sequence that was previously picked. Use Next/Previous to scroll through all the sequence schedule releases and lines that exist for the ship-to and ship-from site combination.

Fig. 3.5
Sequence Cross-Ref Maintenance (7.5.4.13)

The screenshot shows a web application window titled "Sequence Cross-Ref Maintenance". At the top, there is a navigation bar with "Go To" and "Actions" dropdown menus. Below this, there are two input fields: "Ship-From:" and "Ship-To:", each with a search icon. The main content area is titled "Picked/Shipped Sequence" and contains several fields for data entry: "Shipped Release ID:", "Shipped Job:", "Shipped Sequence:", "Shipped Item Number:", "Shipped Reference:", "Shipped Dock:", "Shipped Line Feed:", "Scheduled Date:", "Scheduled Time:", "Shipped:", and "Shipper ID:". There are also checkboxes for "Picked:" and "Shipped:".

The Linked Sequence frame displays next. The field values on this frame refer to the information for the duplicate sequence on the new sequence schedule release. Enter the appropriate values as needed. The system creates a cross-reference link from the picked sequence to the duplicate sequence. The new cross-referenced sequence cannot be picked. The system considers this sequence to be a closed requirement.

Use Sequence Cross-Reference Report (7.5.4.14) to report the cross-reference records you create manually as well as any cross-reference records created automatically when sequences are imported through EDI eCommerce or the shipper gateway.

Referencing Sequence Lines on Scheduled Orders

Use Customer Scheduled Order Maintenance (7.3.13) to create scheduled orders that reference sequence schedule lines. Use the Sequenced field in the Order Data frame to indicate that the scheduled order references sequence schedule lines.

You cannot update the Sequenced field if:

- Customer Sequence Schedules is not activated.
- Trade Sales is set to Yes in Customer Scheduled Order Maintenance. See “Trade Sales” on page 33.

Fig. 3.6
Sequenced Field in Customer Scheduled Order Maintenance (7.3.13)

The screenshot shows the 'Customer Scheduled Order Maintenance' window. At the top, it displays 'Ship-From: 10000', 'Ship-To: matcust', and 'Order: SO218'. Below this, the 'Order Data' section contains various fields and checkboxes. The 'Sequenced' checkbox is checked. A callout box points to the 'Sequenced' field with the text: 'Use this field to indicate whether the scheduled order contains sequences.' Another callout box points to the 'Sequenced' field with the text: 'If this field is Yes, the Sequenced field is display only.'

When you update a scheduled order that has Sequenced set to Yes, the Sequenced Delivery Data frame displays. Use this frame to specify whether sequence schedule data should be included when generating the required ship schedule (RSS), and if so, how many firm days of that data should be used.

Fig. 3.7
Sequenced Delivery Data Frame

The screenshot shows the 'Sequenced Delivery Data' frame. It displays 'Ship-From: 10000', 'Ship-To: 4020', and 'Order: SO193'. Below this, the 'Sequenced Delivery Data' section contains two fields: 'Include Seq in Req Ship Sched' (checkbox checked) and 'Firm Days: 0'.

Include Seq in Req Ship Sched. Indicate whether sequence delivery data should be included when the RSS is generated. This value defaults from the customer control record, if one exists, or Sequence Schedule Control.

Firm Days. When Include Seq in Req Ship Schedule is Yes, this field indicates the number of firm day requirements from the sequence schedule that Required Ship Schedule Update or Selective Req Ship Sched Update should include when generating the RSS.

Firm Days defaults from the customer control record, if one exists, or Sequence Schedule Control.

When you enter more days than are available on the sequence schedule, the maximum available days are used. Enter 0 (zero) to indicate that all available sequence schedule days should be included.

This value affects the way requirements are bucketed on the RSS. When the Req Sched Days value indicated on the scheduled order line exceeds the days indicated here, the system does the following:

- Calculates the difference between this value and the value indicated on the scheduled order line

- Buckets the daily sequenced requirements on the RSS, for the number of days indicated on the scheduled order line

Updating the Required Ship Schedule

Use Required Ship Schedule Update (7.5.5) to generate a new release of the RSS. If Include Seq in Req Ship Schedule is Yes on the scheduled order, the number of firm days indicated are included in the new RSS release. This program updates the RSS release with sequence schedule data only if Sequenced is Yes in the scheduled order being processed.

When you process a scheduled order line, the system checks whether it is associated with a sequence schedule line. This is determined by the Sequenced field setting in Customer Scheduled Order Maintenance (7.3.13).

See “Sequenced” on page 33.

Note Sequenced schedules are not supported when using a trade sales arrangement; therefore, if Trade Sales is Yes, the Sequenced field is displayed only in Customer Scheduled Order Maintenance.

If the scheduled order line is part of a sequence schedule and Sequenced is Yes, sequence schedule-specific netting logic is used to create the RSS release. Netting logic methods work differently when sequences are associated with the scheduled order line.

See “Netting Logic” on page 42.

Option 1: Use Shipping Schedule

The RSS is made up of the sequence schedule days specified in Firm Days in the Sequence Delivery Data frame in Customer Scheduled Order Maintenance. The shipping schedule is appended to the end of these sequence schedule days. The beginning of the ship schedule is replaced by the number of days specified in Firm Days on the scheduled order.

Option 2: Use Planning Schedule

The RSS is made up of the sequence schedule days specified. The planning schedule is appended to the end of the sequence schedule dates. The beginning of the planning schedule is replaced by the number of days specified in Firm Days on the scheduled order.

Option 3: Replace Logic

The RSS is made up of the sequence schedule days specified, followed by the shipping schedule, then the planning schedule.

If you are using this option and Use Ship/Plan PCR is Yes in Customer Schedules Control (7.3.24), the system maintains cumulative quantities for the sequence, shipping, planning, and required ship schedules.

The cumulative quantity for the previous week's planning schedule (prior cumulative quantity) is compared with the current RSS cumulative quantity. If there is a difference because the planning schedule cumulative quantity is greater, the system adds this difference to the current week's planning schedule cumulative quantity. This assures that the current week's planning schedule cumulative quantity is always up to date.

Option 4: Consume Logic

The RSS is made up of the sequence schedule days specified, followed by the shipping schedule, then the planning schedule. The system maintains cumulative quantities for the sequence, shipping, planning, and required ship schedules. The cumulative quantities of the sequence and shipping schedules are used to ensure that the weekly requirements from the planning schedule are accounted for or consumed.

The system follows these steps when generating the RSS:

- The sequence schedule is processed first. Cumulative quantities are calculated for the sequence schedule.
- The shipping schedule is processed next. The dates and quantities from the shipping schedule are appended to the end of the sequence schedule.
- The planning schedule is processed next. The cumulative quantities for each week of the planning schedule are compared to the weekly quantity of the sequence and shipping schedule.
- If the weekly cumulative quantity of the sequence or shipping schedule is less than the weekly planning quantity, that schedule is updated to match weekly planning quantity. To do this, the system adjusts the last entry in the week by the difference of the two schedules. The remaining dates and quantities from the planning schedule are appended to the end of the shipping schedule.
- If the weekly cumulative quantity of the sequence/shipping schedule is greater than or equal to the planning schedule for the week, no adjustments are made.
- The dates and quantities from the planning schedule are appended to the end of the sequence/shipping schedule.

Calculations with Netting Logic 1, 2, or 3

If you are using netting logic 1, 2, or 3 and a sequence or shipping schedule ends in the middle of the weekly planning interval, any open requirements on the planning schedule are moved to the next available open date using the following steps:

- The system first calculates the amount of weekly requirements from the sequence/shipping schedule.
- It then compares this to the weekly planning requirements. If the weekly requirements exceed the sequence and/or shipping scheduled requirements, the difference is added to the next open date.
- The system calculates the next open date using the customer calendar and adding one day to the last sequence or shipping requirement in the week.
- A new requirement is created on this day and contains the open requirements from the weekly planning schedule. If the next open date falls into the following week, no adjustments are made because the week has ended.

Note This applies only if SDP codes are not being used for the schedule. See “Netting Logic 3 with SDP Codes” on page 85.

Example The planning schedule begins on Monday, the first day of the week. The sequence/shipping schedule ends on Wednesday. The schedules overlap three days: Monday, Tuesday, and Wednesday. The system finds the difference between the three-day requirements from the sequence/shipping schedule and the three-day requirements for the planning schedule. If the planning schedule requirements exceed the sequence/shipping schedule requirements, it moves that amount of planning requirements to Thursday, the next available open date.

When you generate an RSS release that contains sequences, the following sections appear on the RSS report:

- Sequence Schedule Required Quantities
- Netting Options
- Seq Schedule Adjustment For Plan Schedule Overlap
- Combined Schedule
- Schedule Dates Backward Adjusted for Customer or Ship-To Calendar

Netting Logic 3 with SDP Codes

The system creates the RSS differently when you use netting logic 3 with the Use Ship/Plan PCR field in Container/Shipper Control. This field lets you specify whether the system considers prior cumulative requirements (PCR) when it reconciles shipping and planning schedules to create the RSS. The PCR quantity depicts all quantities needed before the current schedule goes into effect. Adding the PCR quantity can greatly increase the demand, particularly when the system adds the PCR quantity along with consumed planning quantities.

See “Plan SDP, Ship SDP” on page 42.

Updating Specific Required Ship Schedules

Use Selective Required Ship Schedule Update (7.5.6) to create a specific RSS release that includes any associated sequence schedule. Specify the sequence schedule release ID to use in Sequence Schedule Release ID. Only sequence lines associated with the specific scheduled order lines are used. Required ship schedules that include sequence schedule data are generated as described in the previous section.

Fig. 3.8
Sequence Schedule Release ID Field

The screenshot shows a software window titled "Selective Req Ship Sched Up...". The window contains the following information:

- Ship-From: 10000
- Ship-To: 1002AB
- Item Number: TT-500L
- PO Number:
- Customer Ref:
- Model Year:
- Order: SO234
- Quality Products Div 1000
- L-model wire clip
- Line: 1
- UM: EA
- Ship Schedule Release ID: [Text Field]
- Plan Schedule Release ID: [Text Field]
- Sequence Schedule Release ID: [Text Field]
- Report:
- Update:
- Output:

Fields added by Customer Sequence Schedules.

Including Sequences on Picklists and Pre-Shippers

Use Picklist/Pre-Shipper–Automatic (7.9.1) to build shippers with or without sequence data.

To generate a shipper containing sequences, the system follows these steps:

- Determines the open quantity from the unpicked sequences in the sequence schedule using the number specified in Firm Days to limit the number of sequences from the active release to include. The open quantity does not include any sequences that have been picked, cross-referenced, or have Deleted set to Yes.
- Performs allocations and picks inventory for the open quantity, marking each sequence as picked.
- Moves picked sequences into multiple pre-shippers if either or both line feed and customer dock are specified.
- Prints each pre-shipper with the first section displaying gross quantities by part. The following section displays the sequences in sequential order and any related information. If the sequences are being delivered to a customer dock or line feed, that information prints on the first section of the pre-shipper.
- Prints the sequenced packing list in forward or reverse order, as indicated in the customer control record, or if one does not exist, as specified in Sequence Schedule Control.
- Shows breaks between sequences as specified in Sequences Per Container in the customer control record or if one does not exist, as specified in Sequence Schedule Control.

When creating a sequenced picklist, the Picklist/Pre-Shipper Sequence Pack List section on the printed document displays sequence information.

Creating Sequenced Pre-Shippers

Use Sequence Pre-Shipper–Automatic (7.5.4.10) to create pre-shippers for one or a range of sequence schedules. The selection criteria for this program applies only to sequence schedules. To create pre-shippers for ranges of both sequenced and non-sequenced schedules, use Picklist/Pre-Shipper–Automatic (7.9.1).

Fig. 3.9
Sequence Pre-Shipper– Automatic (7.5.4.10)

Sequence Pre-Shipper–Automatic selects sequences from active schedules. The sequences must match the selection criteria, and cannot be marked as deleted, picked, or cross-referenced. It arranges the sequences by ship/delivery date and destination and creates the pre-shippers as needed. All processing occurs as in *Picklist/Pre-Shipper–Automatic* (7.9.1).

Sequenced pre-shippers are printed as two documents:

- The first document displays the total gross requirements. This is the same as the one produced by *Picklist/Pre-Shipper–Automatic*.
- The second document shows all the sequence information in order by sequence.

Status and the selection criteria ranges refer to sequence schedule information. Most of the fields on the bottom half of the screen are the same fields found in *Picklist/Pre-Shipper–Automatic*.

See *QAD Sales User Guide*.

Break on Maximum Sequence. This is an optional control field used to specify the maximum number of sequences allowed on a shipper.

The default is 0 (zero). Leave this value to indicate that the shipper can contain an unlimited number of sequences.

When adding a sequence to a shipper, the system first checks to make sure that this number of sequences has not been reached on the shipper. When a shipper reaches this number of sequences, a new shipper is created. Any additional sequences are added to the new shipper.

Maintaining Sequences on a Pre-Shipper/Shipper

Use Pre-Shipper/Shipper Workbench (7.9.2) to view and add or delete sequences from a pre-shipper/shipper.

The Display Sequences frame shows all the sequences on the pre-shipper/shipper; see Figure 3.10 on page 88. This frame displays only if the pre-shipper/shipper contains sequences. If it does not, but the scheduled order does contain sequences, the Add Sequences frame displays; see Figure 3.11.

Fig. 3.10
Display Sequences Frame

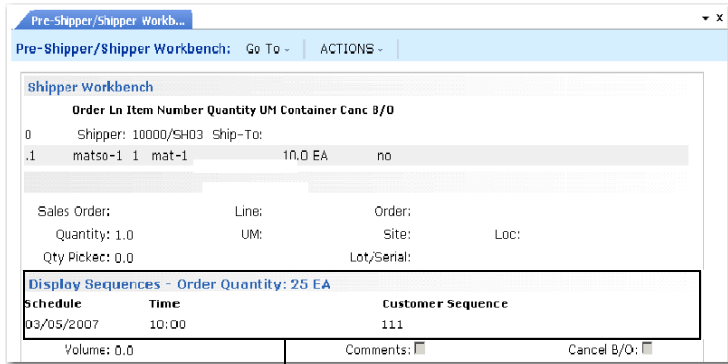

Sequence data displays for shipper.

To remove any of these sequences from the pre-shipper/shipper, scroll to the sequence to delete and press Delete. Once you confirm the delete, the system removes the sequence from the list and updates the sequence record, setting it as an open requirement.

Note Use the up/down arrows to scroll the sequence list.

Fig. 3.11
Add Sequences Frame

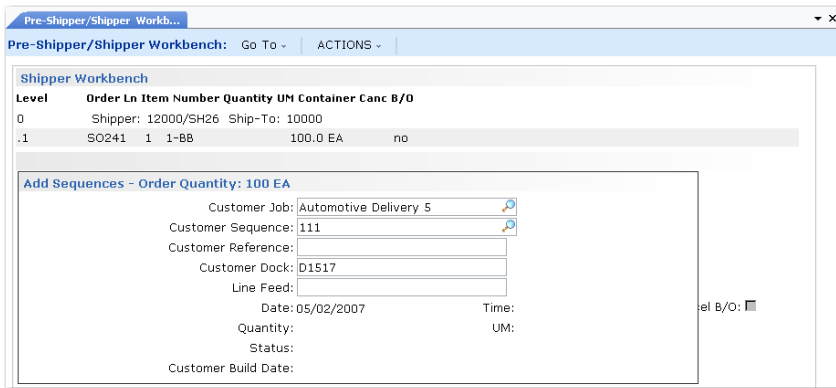

When you initially add a shipper line to a pre-shipper/shipper using this program, the system always displays the Add Sequences frame. This frame is used to add sequences to the pre-shipper/shipper. In the Add Sequences frame, press Add to add additional sequences to the pre-shipper/shipper. The Add Sequences frame appears. Use the Customer Job, Sequence, Reference, Dock, and Line Feed fields to indicate the sequence that should be added to the pre-shipper/shipper.

Only sequences from the active schedule release that are not marked as deleted, picked, or cross-referenced can be added to the pre-shipper/shipper. When you add a new sequence to the pre-shipper/shipper, that sequence is marked as having been picked.

With Pre-Shipper/Shipper Workbench, you can optionally print the completed pre-shipper/shipper. A range of sequence numbers associated with the pre-shipper/shipper prints on the document as indicated in Print Sequence Range on Shipper in the customer control record for the ship-to, or Sequence Schedule Control. After the pre-shipper/shipper is printed, a sequence packing list is also printed automatically on a separate page.

You can also use Pre-Shipper/Shipper Print (7.9.4) to print the pre-shipper/shipper. It also prints a separate packing list and can include the associated range of sequence numbers. When you print the pre-shipper, you can optionally convert it to a shipper by setting Assign Shipper Numbers to Yes. Any sequences on the shipper are updated with the shipper number. This program processes the printing of the pre-shipper/shipper in the same way as Pre-Shipper/Shipper Workbench.

Use Undo Shipper Number Assignment (7.9.20) to reverse shipper number assignments for unconfirmed shippers. This restores the original pre-shipper number and changes the document type from shipper back to pre-shipper. It also updates the pre-shipper/shipper number on sequences associated with the shipper.

Maintaining Sequences in Containers

Use SO Container Maintenance (7.7.5) to view and add or delete sequences from a sales order container. The frames used in Pre-Shipper/Shipper Workbench (7.9.2) also display here. You view, add, and delete sequences for a container the same way you would for pre-shipper/shippers.

See “Maintaining Sequences on a Pre-Shipper/Shipper” on page 87.

Maintaining Sequences on Sales Order Shippers

Use Sales Order Shipper Maintenance (7.9.8) to view and add or delete sequences from a sales order shipper.

The frames used in Pre-Shipper/Shipper Workbench (7.9.2) also display here. You view, add, and delete sequences from a SO shipper the same way you would for pre-shipper/shippers. This program processes the printing of the sales order shipper the same way as Pre-Shipper/Shipper Workbench.

You can also use Pre-Shipper/Shipper Print (7.9.4) to print the completed sales order shipper, which includes the associated sequences. Printing of the sales order shipper is processed in the same way Pre-Shipper/Shipper Workbench processes the printing of a pre-shipper/shipper.

See “Maintaining Sequences on a Pre-Shipper/Shipper” on page 87.

Confirming and Unconfirming Shippers

Use Pre-Shipper/Shipper Confirm (7.9.5) to record shipments of orders and to:

- Convert pre-shippers into shippers.
- Create, post, and print invoices based on shipments.

See *QAD Sales User Guide*.

You can export a confirmed shipper as an advance ship notice (ASN) to inform your customer that an order has been shipped. Export ASNs using EDI eCommerce.

See *QAD EDI eCommerce User Guide*.

When you confirm a sequenced order, the associated sequences are marked as confirmed. If you create an invoice for a sequenced order, a range of the sequence numbers included on the order may print on the invoice. Additionally, this sequence number range may also be included when you export a shipper as an ASN. The inclusion of sequence number ranges is dependent on the customer control record or Sequence Schedule Control settings.

Use Shipper Unconfirm (7.9.21) to reverse all the sequence-related actions performed by the system at confirmation, returning the shipment to its pre-confirmed state and allowing it to be subsequently modified, canceled, reprinted, or reconfirmed.

Sending ASN Documents with Sequence Information

Use Shipment ASN Export (35.4.1) to export the ASN from your system. An exported ASN can optionally include any sequence information associated with it. The inclusion of sequence information is dependent on the setting in Send Sequence with ASN in a ship-to's customer control record, or in Sequence Schedule Control.

See *QAD EDI eCommerce User Guide*.

Posting, Exporting, and Printing Invoices

When you post an invoice using Invoice Post and Print (7.13.4), the system checks whether any sequences are associated with that invoice. If the invoice references shipments of sequenced items, the sequence shipper records are updated with a reference to the invoice number being posted.

This reference is used to print a range of sequence numbers on the invoice whenever it is printed with Invoice Post and Print, or any other function that prints invoices. The inclusion of the range of associated sequence numbers on the printed invoice is dependent on the customer control record or Sequence Schedule Control settings. The range prints at the end of the invoice, once all invoice lines have been printed.

When you export an invoice that is associated with sequence schedule lines, that invoice can optionally include the sequence information associated with it. The inclusion of sequence information is dependent on the customer control record or Sequence Schedule Control settings. Use Invoice Export (35.4.3) to export invoices with EDI eCommerce.

Fig. 3.12
Sequence Number Range Printed on an Invoice

Item Number	UM	Shipped	Backorder	Tax	Price	Ext Price
item x	EA	10.0	0.0	no	100.00	1,000.00
Item x						
Purchase Order: po101						
Customer Job: job1						
		Sequence Ranges				
		Sequence	To			
		seq2	seq2			

The following programs also print a range of sequence numbers on the invoice based on the customer control record or Sequence Schedule Control settings.

- Invoice Print or Reprint (7.13.12)
- Pre-Shipper/Shipper Confirm (7.9.5)
- Shipper Unconfirm (7.9.21)

Removing Historical Sequence Data

Use Schedule Delete/Archive (7.5.23) to selectively delete/archive inactive sequence schedules and any associated inactive detail and cross-reference records. Use the Sequence field to indicate whether sequence schedules that fit the selection criteria should be deleted/archived.

Section 2

Supplier Schedules

This section discusses how to set up and process supplier schedules and the optional supplier shipping schedules.

***Supplier Schedules* 95**

Describes the functions of the supplier schedules module.

***Supplier Shipping Schedules* 117**

Describes how to set up and use the optional Supplier Shipping Schedules module.

Supplier Schedules

Supplier schedules supports generation of supplier releases, incorporating a set of scheduled receipt dates and quantities.

Note The QAD Document Library includes related training material. See [QAD Supplier Schedules Training Guide](#).

Introduction to Supplier Schedules 96

Defines supplier schedules and explains their characteristics.

Setting Up Supplier Schedules 98

Explains what data and which parameters are necessary to use supplier schedules.

Processing Supplier Schedules 108

Describes the three steps necessary to process a supplier schedule.

Receiving Scheduled Orders 112

Illustrates how receipts and documents are used to deal with scheduled order processing.

Deleting Supplier Scheduled Orders 116

Describes how to delete and archive scheduled orders using Closed PO Delete/Archive.

Introduction to Supplier Schedules

Supplier schedules are cumulative, schedule-driven purchase orders with multiple line items from which releases of requirements and due dates are issued. They are typically used by companies with long-term supplier contracts that require regular weekly or daily deliveries. The schedules specify, for the near term, dates and even hours of deliveries. But they also inform MRP and the supplier about long-term plans.

The header and trailer of a supplier schedule resemble those of a normal purchase order for a single line item with multiple delivery dates. However, the line-item section of a supplier schedule combines information for:

- Short-term shipping schedule with exact quantities and delivery instructions
- Long-term planning schedule that shows upcoming orders and authorizes the supplier to buy raw materials or make subassemblies

Note If you have the optional Supplier Shipping Schedules module you can generate separate supplier planning and shipping schedules, rather than one schedule that combines both. For details, see “Supplier Shipping Schedules” on page 117.

As with a regular purchase order, the items listed in a supplier schedule are seen by the system as supply. You can also receive items against a supplier schedule.

Supplier schedules are used for multiple deliveries from a supplier who needs to adjust production to accommodate your orders.

Example A manufacturer of circuit boards needs blank boards supplied each week. The manufacturer knows exact needs for the next few weeks and approximate needs for the next 12 months. The supplier of these circuit board blanks needs this information to place orders for raw materials and plan production. Supplier schedules are needed to set up delivery.

The Supplier Schedules Menu (5.5) includes the following:

- Supplier Schedule Setup Menu (5.5.1)
- Supplier Schedule Processing Menu (5.5.3)
- Supplier Receipts Processing Menu (5.5.5)
- Supplier Shipping Schedules (5.5.7)

Schedule Order Characteristics

Table 4.1 contrasts the characteristics of scheduled orders with other kinds of purchase orders.

Table 4.1
Summary of Purchase Order Characteristics

	Supplier Schedules	Purchase Orders	Blanket Orders
Delivery Dates	Multiple	Single for order/item	Multiple
Seen by MRP	Yes	Yes	No
Receipts	Yes	Yes	No

	Supplier Schedules	Purchase Orders	Blanket Orders
Duration	Medium/long-term	One time	Short/medium
Elements	Header Planning schedule Shipping schedule Trailer	Header Line Items Trailer	Header Line Items Trailer POs

Effective Dates

The system considers effective dates when it processes schedules. It determines whether a scheduled order line is active before assigning demands to the schedule release that it creates for the order or supplier.

Scheduled orders have both header start and end effective dates and line start and end effective dates. The header start effective date determines when the order is active, while the header end effective date determines when the order is inactive. The system uses the line start date and the earlier of the header or line end date as the active line date range when processing line items. This is illustrated in Figure 4.1 on page 97.

See “Start Effective” on page 100.

Fig. 4.1
Active Line Dates

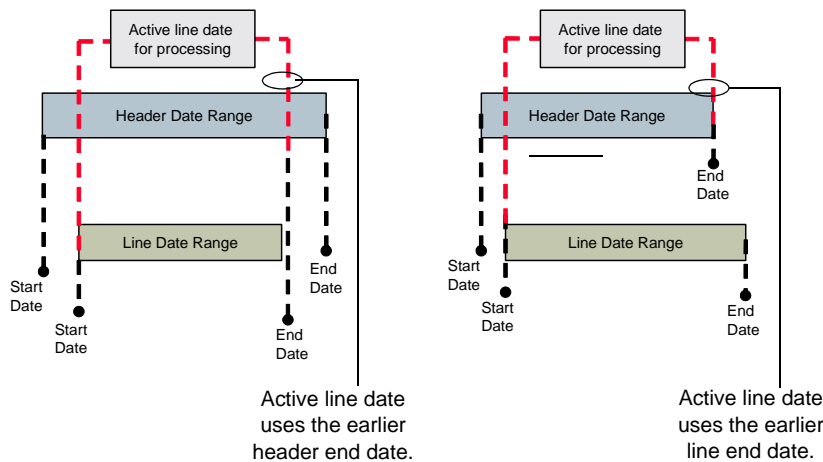

The system prohibits the following if the line item is inactive:

- MRP % allocation
- Schedule processing
- Shipper creation
- Receipt processing, including ASNs

The system also prohibits you from deleting or archiving scheduled orders if they are active.

You can return items for inactive lines. To make a line active again to continue processing, change the scheduled order header end date to a later date in Supplier Scheduled Order Maintenance (5.5.1.13).

Two reports let you display scheduled order data based on effective date ranges:

- Scheduled Order Report (5.5.1.15)
- 5.5.1.12
- Order End Effective Report (5.5.1.16)

Use Scheduled Order Report to display scheduled order lines that are active during a specified time period. The system displays scheduled order lines that have an active date range that falls within the date range you specify or overlaps the date range you specify.

Use Order End Effective Report to display scheduled orders and lines that close during a specified time.

Zero Schedules

When there is no demand for an item, you can create a zero-quantity schedule as a way of informing suppliers that an item is not needed. Zero schedules have a single-line order with a quantity of zero to indicate the item is no longer required from the supplier. You can create a zero-quantity schedule when:

- The prior schedule has zero net requirements.
- A record exists in Scheduled Order MRP % Maintenance (5.5.1.17) or Subcontract Order MRP % Maintenance (5.5.1.21).
- The number of zero schedules sent by the system does not equal the number specified in Supplier Scheduled Order Maintenance (5.5.1.13).

Note The system count of zero schedules does not include zero schedules you manually create in schedule maintenance programs.

You set the number of zero schedules the system generates for a supplier when an order is active but no demand exists in Supplier Schedule Control (5.5.1.24). This value defaults to the same-named field in Supplier Scheduled Order Maintenance (5.5.1.13).

See “Zero Schedules” on page 99.

Setting Up Supplier Schedules

To use supplier schedules, you must set up the same baseline data required for purchase orders, including purchased items and supplier addresses. MRP uses item parameters specified in Item Master Maintenance (1.4.1) to create planned purchase orders for scheduled items. These orders contain due dates, release dates, and order quantities.

Setting Control Program Values

Use Supplier Schedule Control (5.5.1.24) to define default values for release IDs and zero schedules.

Fig. 4.2
Supplier Schedule Control (5.5.1.24)

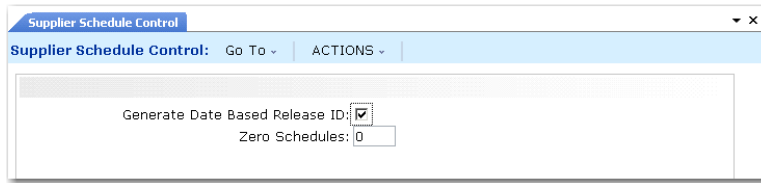

Generate Date Based Release ID. Specify whether Schedule Update from MRP generates a date-based release ID instead of a numeric release ID. The system generates date-based release IDs using the current date plus an incrementing integer value. For example, Schedule Update from MRP generates a schedule on November 24, 2005, and the system creates release ID 20051124-001. The system does not generate date-based release IDs when you manually create a supplier schedule.

No (the default): Schedule Update from MRP generates numeric release IDs.

Yes: Schedule Update from MRP generates eleven digit date-based release IDs using the following components:

- The four-digit year
- The two-digit month
- The two-digit day
- A three-digit release number

Zero Schedules. Enter the number of zero schedules the system generates for a supplier when an order is active but no demand exists. You can enter a zero so that the system never creates a zero schedule. This value defaults to Zero Schedules field in Supplier Scheduled Order Maintenance (5.5.1.13).

See “Zero Schedules” on page 101.

Creating Supplier Calendars

If your supplier works different days than you do, set up a supplier-specific calendar for them in Supplier Calendar Maintenance (5.5.1.1). Schedule Update from MRP considers these calendars when generating schedule releases.

You must set Calendar/Working Firm Days to Calendar in Schedule Update from MRP (5.5.3.1) for the system to consider the supplier calendar when generating schedule releases. Also, the system uses the value of the Calendar/Working Firm Days field when printing schedule firm days in Schedule Print (5.5.3.8). If you specify working schedules, the system treats holidays as nonworking days when the supplier schedule is calculated with working firm days.

For suppliers that do not have supplier-specific calendars, the system uses the applicable shop calendar. For information on setting up supplier and shop calendars, see [QAD System Administration User Guide](#).

Creating Scheduled Orders

Create a supplier scheduled order in Supplier Scheduled Order Maintenance (5.5.1.13). You must define several parameters that the system uses to calculate receipt, planning, and shipping schedules for individual items that have been entered on separate purchase order lines. This order provides the framework for a contract, but has no delivery dates.

After you enter an order ID and supplier code, additional detail frames display. The first contains shipping and credit information for the whole order. The next contains line-item information such as item numbers, ship-to data, line-item details, schedule details, and optional comments.

Note You cannot edit a scheduled order in Purchase Order Maintenance (5.7), if you try, the system displays an error message.

Header

Several values in the header frame indicate how schedules based on this order are delivered to suppliers. Schedules can be printed, transmitted using EDI eCommerce, or sent by FAX, depending on the values you specify.

See “Transmitting Supplier Schedules” on page 111.

Important fields in the header that impact schedule processing are described following Figure 4.3.

Fig. 4.3
Supplier Scheduled Order Maintenance (5.5.1.13), Header Frame

Supplier Scheduled Order Maint

Go To Actions Copy Print Preview

Purchase Order: P01048 Supplier: 5000

Acme Supply Co

Order Data

Start Effective: 7/18/2008 Ship Via:
 End Effective:
 Taxable: FOB:
 Tax Class: 004 Buyer:
 Credit Terms: 2/40PROX Contract:
 Bill-To Address: 10000000 Currency: USD
 Ship-To Address: 10000 Fixed Price:
 Print Schedules: Order Revision: 0
 EDI Schedules: Order Rev Date:
 Fax Schedules: Print PO:
 A/P Site:
 Consignment: Daybook Set: AP2DB
 Zero Schedules: 1 Comments:
 Import/Export:

Start Effective. Specify a start date for this scheduled order. For new orders, the default is blank. However, you cannot leave this field blank; otherwise, an error displays. Enter any date that is before or after the system date and earlier than or the same as the header end date.

The start date defaults to the Line Start Effective field if it is after the system date. If it is earlier than or on the system date, the system date defaults to the Line Start Effective field.

If you change the header start date and line items already exist on the scheduled order, you must specify a start date that is earlier than the line start dates.

See “Effective Dates” on page 97.

End Effective. Specify an end date for this scheduled order or leave blank. If you specify a date, the date must be later than or the same as the header start effective date. If blank, the order is open. The date you enter here defaults to the line End Effective field.

You can close a scheduled order by assigning a date that is earlier than the system date. When you do:

- You cannot add new lines to the order.
- The system automatically closes lines with an end date earlier than the date you specify.
- The system makes all lines with an end date later than the date you specify inactive.

Although the system warns you that the order lines are inactive, you can still change information on the order. You cannot add new lines though.

Zero Schedules. Enter the number of zero schedules the system generates for a supplier when an order is active but no demand exists. A zero schedule is a one-line schedule for zero quantities that suppliers still receive and process until some agreed-upon point in time when the customer stops sending the zero-quantity schedules. You can enter a zero so that the system never creates a zero schedule.

The system uses the Zero Schedules field to determine if the maximum number of zero schedules has been generated for a scheduled order line before creating a new zero schedule in Schedule Update From MRP (5.5.3.1). The system stops generating zero schedules for the combined supplier, order, and line when it reaches the number you specify.

Note The system count of zero schedules does not include zero schedules you manually create in schedule maintenance programs.

This field defaults from the same-named field in Supplier Schedule Control (5.5.1.24).

Fixed Price. This field sets the default for the line. See “Fixed Price” on page 104.

Order Revision. Enter a value identifying the revision level of this order. Use revision numbers to identify the most current copy of a document. When an order is initially created, revision defaults to zero.

Each time the order changes, you can manually increase the revision number by 1; however, there are no restrictions on incrementing numbers. A new copy of the document can be printed listing the current information along with the revision number.

When you access an existing order, the system prompts you to specify whether you are making an order revision change when you attempt to leave the header frame. You can specify No and continue accessing the order. If you specify Yes, you must enter a new revision level in the Order Revision field.

The system automatically sets the Print PO field to Yes when you modify the revision level.

Order Rev Date. Specify the date the revision level is effective. The default is blank.

Daybook Set. Specify the daybook set that will be used to number supplier invoices that originate from this scheduled order. The default daybook set is copied from the supplier record in Supplier Data Maintenance (2.3.1), but you can overwrite it with a new value.

See *QAD Financials User Guide* for more information on daybook sets.

When you are finished entering values in the header frame, click Next to display the line-item frame.

Line Items

Use fields in the first line-item frame to specify an item to be ordered from the supplier and the site to receive that item. Unique line numbers enable you to enter more than one schedule line for the same item, if needed, as long as each line has a different ship-to site.

Fig. 4.4
Supplier Scheduled Order Maintenance, Item and Ship-To Site

The screenshot shows a window titled "Supplier Scheduled Order Ma...". The main area contains the following information:

- Purchase Order: P1131
- Supplier: 5010
- Wholesale Supply Co.
- Item Number: [text input field]
- Ship-To Site: [text input field]
- Line: [text input field]

First Order Line item Data Frame

Use fields in the first Order Line Item Data frame to specify pricing and inventory data for the item referenced in the previous frame. Figure 4.5 depicts the frame. Fields that impact schedule processing are described after the figure.

Fig. 4.5
Order Line Item Data, First Frame

The screenshot shows a window titled "Supplier Scheduled Order Ma...". The main area contains the following information:

- Purchase Order: P1121
- Supplier: 5000
- Acme Supply Co.
- Item Number: 2005
- Ship-To Site: 10000
- Line: 1

Order Line Item Data

- Discount Tbl: [text input field]
- Unit Cost: 0.00
- Pur Acct: 5100
- Taxable:
- Type: M
- Consignment:
- PO Revision: [text input field]
- Item Rev Date: [dropdown menu]
- Update Current Cost:
- Location: [text input field]
- Fixed Price:
- Unit of Measure: [text input field]
- UM Conversion: 1.0000
- Work Order ID: [text input field]
- Operation: 0
- Subcontract Type: [text input field]

Discount Tbl. Enter the discount table for this order. You cannot leave this field blank if you set Schedule Discount Table Req to Yes in Purchasing Control.

The system uses the current date for price list Start and Expire Date comparisons.

For scheduled orders, Price List—in PO Shipper Receipt and Purchase Order Receipts—automatically phases in prices as they become effective when Fixed Prices is set to No on the scheduled order being received.

If a price list exists at the time of receipt and Fixed Price is set to No on the order line, the system uses price list logic to determine the price to post. If no price list exists, the system posts the amount in Purchase Cost.

Create a price list with the item number of the line item, a blank product line, unit-of-measure the same as the stocking unit-of-measure for the item, currency equal to the supplier's, and an amount type of P (price), D (discount), or M (mark-up). Discount tables entered in this field must be created through Supplier Price List Maintenance. Price tables (type L) are not considered for scheduled orders.

Type. This field determines the effect on inventory, planning, and cost accounting when the item is received in a purchase order. Type defaults from Memo Order Type in Item-Site Inventory Data Maintenance (1.4.16), if defined for the order line site; otherwise, it defaults from Item Master Maintenance (1.4.1).

Blank: This line item is received into inventory. When the receipt is processed, inventory balances are increased and a general ledger (GL) transaction debits the Inventory account. Inventory items are considered supply by MRP.

Non-blank: This item does not affect inventory and does not create an Inventory GL transaction. For a non-inventory item, type defaults to M (memo). Memo items are expensed or capitalized upon receipt, depending on the Purchases account for the item. Memo items have no effect on MRP.

S: Subcontract. This line item is for a subcontract operation. A work order number, lot ID, and operation are specified on the order and on the receipt. When the receipt is processed, work order operation status is updated and a GL transaction debits the WIP account from the work order.

B: Blanket. This line item is for a blanket order. The system sets the line type to B in Blanket Order Maintenance, and you cannot change it. You cannot specify B on any other type of order.

Supplier schedules are designed to track the ongoing agreement between supplier and customer for inventory or subcontract items. Therefore, Type codes in Supplier Scheduled Order Maintenance (5.5.1.13) are typically blank (inventory) or subcontract.

Item Revision. Enter the code representing the revision level of the item. This field is validated against predefined values entered in Generalized Codes Maintenance (36.2.13) for field `pod_rev`. This field defaults from the Revision field in Item-Site Planning Maintenance (1.4.17). If no revision exists there, it defaults from the Revision field in Item Master Maintenance (1.4.1).

Do not confuse the header order revision with the line item revision. Order revision indicates whether changes have been made to the scheduled order; it has no default. Item revision indicates changes have been made to the engineering version of the item; the level defaults from either Item-Site Planning Maintenance (1.4.17) or Item Master Maintenance (1.4.1).

When you copy a schedule line from another schedule line, the new schedule line inherits the source item revision level and date.

When you export schedule information using the following programs, the item revision level and item revision date from the schedule are included in the information:

- Supplier Schedule Gateways (35.4.8)
- 850 Purchase Order Export (35.4.9)

Item Rev Date. Specify the date the item revision level is effective. The default is blank.

Fixed Price. Indicate whether a price lookup should occur at scheduled order receipt or, if you use Evaluated Receipts Settlement (ERS), whether the ERS Processor determines a new invoice cost for the line item when creating an invoice. The difference between the extended cost entered on the PO and the extended cost determined by the ERS Processor for the supplier invoice is posted to the AP Variance account.

Yes: The system does not look up prices during scheduled order receipt and the ERS processor does not determine a new invoice for the line item when creating a supplier invoice.

No: The system looks up prices during scheduled order receipt and copies the value of this field to the receiver. If you use ERS, the ERS processor determines a new invoice cost for the line item when creating a supplier invoice.

The quantity for scheduled order lines typically comes from planning, shipping, or required schedules. For this reason, scheduled order lines typically have a 0 (zero) quantity. Since scheduled orders typically do not have an order quantity to determine a price, PO costs on scheduled orders are not affected; therefore, this field has no effect for scheduled orders when you run Purchase Order Cost Update (5.19). During receipt, the system does, however, look up new prices for scheduled order lines with a discount table and updates the PO cost based on the quantity that you receive.

Work Order ID. Enter the work order ID or cumulative order ID associated with a subcontract item. If you use the Advanced Repetitive module, you can leave this field blank. The system validates this field when the order type is S and automatically updates the ID when it creates a cumulative ID in Advanced Repetitive transactions.

Operation. Specify the operation code for the operation that the subcontractor performs. If you use the Advanced Repetitive module, you can leave this field blank. The system validates this field when the order type is S and automatically updates the operation field when it creates a cumulative ID in Advanced Repetitive (18.22) transactions.

Second Order Line Item Data Frame

Use fields in the second Order Line Item Data frame to record data that impact the requirements and schedules generated for the associated line item.

Fig. 4.6
Order Line Item Data, Second Frame

The screenshot shows a software window titled "Supplier Scheduled Order Ma..." with a menu bar containing "Supplier Scheduled Order Maint:", "Go To ~", and "ACTIONS ~". The main content area displays the following information:

- Purchase Order: P1121
- Supplier: 5000
- Acme Supply Co
- Order Line Item Data**
- Firm Days:
- Schedule Days:
- Schedule Weeks:
- Schedule Months:
- Fab Auth Days:
- Raw Auth Days:
- Transport Days:
- Safety Days:
- Supplier Item:
- Container Item:
- Ship Delivery Pattern Code:
- Max Order Qty:
- Std Pack Qty:
- Cum Start:
- Comments:
- Start Effective:
- End Effective:

Firm Days. Specify the number of days inside the schedule update time fence for scheduled release calculations. These days should not exceed the number specified in Schedule Days.

Quantities and dates within this period are not changed by Schedule Update from MRP (5.5.3.1). Set Firm Days to zero to eliminate the update time fence. Do this when all requirements are released as planned so that the schedule update replans all dates and quantities.

See “Effect of Firm Days” on page 109 for more details.

Note This value does not affect how MRP uses the Time Fence value defined for the item. Firm Days controls order releases by date and quantity. The item master Time Fence field controls planned orders by date and quantity.

Schedule Days. Specify the number of days of discrete dates and quantities to appear on printed or transmitted releases and on reports and inquiries, including intraday quantities and times. See “Schedule Bucketing” on page 112 for details.

Schedule Weeks. Specify the number of weekly bucketed quantities to appear on printed or transmitted releases and on reports and inquiries following any Schedule Days dates and quantities. Each quantity represents the total requirement for the Monday through Sunday week. Bucketing is for print and reporting purposes only. Internally, the system stores all requirements by discrete dates and quantities.

Schedule Months. Specify the number of monthly bucketed quantities to appear on printed or transmitted releases and on reports and inquiries following weekly buckets and discrete dates and quantities. Each quantity represents the entire month’s requirements from the first Monday up to the first Monday of the following month.

Fab Auth Days, Raw Auth Days. Raw and fabrication authorization commitments are made to give suppliers some protection against sudden and unforeseen reductions in demand.

- Raw quantity is the quantity of product you commit to covering the component costs.
- Fab quantity is the quantity of product you commit to covering manufacturing costs.

Note Schedule Update from MRP uses these values only if scheduled requirements extend beyond the number of days in the authorization horizon. Otherwise, the authorization horizon equals the schedule days.

Transport Days. This field is normally blank. Specify a value for suppliers who do not ship or take responsibility for shipping, but from whom you pick up or schedule the pickup of orders. Entering a value in Transport Days converts all order dates from receipt dates to shipment dates.

Schedule Update from MRP uses this value to set shipment dates based on delivery dates (delivery date – transport days). It then checks the supplier’s calendar, if one exists, to verify that the shipment date is a workday for the supplier. If not, the update back-schedules to the next supplier workday.

All reports and inquiries check this field to verify whether to print or display delivery dates or shipment dates. When this value is positive, the system uses shipment dates.

Safety Days. Enter the number of calendar days early that the MRP required date will be adjusted. Schedule Update from MRP creates schedule dates from MRP requirement dates this many days early. Specifying these early days provides a safeguard when deliveries may be late.

Supplier Item. Specify the item number by which the supplier identifies this item. The default is blank. Both your item number and the supplier item number display on reports and inquiries, print on order documents, and display during order receipt functions. This helps receiving clerks who receive packing lists that show only supplier item numbers.

Container Item. Optionally enter the item number of the container in which the item will be delivered. The value must be a valid item number defined in Item Master Maintenance (1.4.1).

Ship Delivery Pattern Code. Enter a code for the routine ship or delivery pattern, the days of the week or month when deliveries are required.

Schedule Update from MRP uses ship/delivery patterns to calculate actual supplier schedule required dates. MRP generates quantities, but the quantities are not divided into buckets as they are in customer schedules. MRP may shift quantities to earlier dates, if necessary, as defined by the ship/delivery pattern code.

Example The pattern specified is 1/3 Monday, Wednesday, Friday (code 26). Supplier Schedule Update from MRP receives a quantity for Thursday. The entire MRP-generated quantity shifts to Wednesday, since Wednesday is the closest date prior to Thursday for this ship/delivery pattern.

You can use ship/delivery pattern codes for both planning and shipping schedules. You would ordinarily use pattern codes only for planning schedules that use bucketed quantities frequently.

SDP codes support both the Organization for Data Exchange by Teletransmission in Europe (ODETTE) and the Automotive Industry Action Group (AIAG) ship/delivery patterns. They are translated to the appropriate industry-standard codes during EDI conversion and transmission.

The system recognizes and supports only the following codes:

blank: Any day, Monday through Sunday	12 or D: Monday	25: 1/2 Tuesday, Friday
01 or 1: First week of month	13 or E: Tuesday	26: 1/3 Monday, Wednesday, Friday
02 or 2: Second week of month	14 or F: Wednesday	27: 1/4 Monday, Tuesday, Wednesday, Thursday
03 or 3: Third week of month	15 or G: Thursday	28: 1/3 Monday, Tuesday, Thursday
04 or 4: Fourth week of month	16 or H: Friday	29: 1/3 Monday, Wednesday, Thursday
05 or 6: 1/2 first and third weeks of month	20 or 1/5: Monday through Friday	30: 1/4 Monday, Tuesday, Wednesday, Friday
06 or 7: 1/2 second and fourth weeks of month	21 or Q: 1/2 Tuesday, Thursday	31: 1/4 Tuesday, Wednesday, Thursday, Friday
07: First day of month	22 or R: 1/2 Wednesday, Friday	32: 1/3 Tuesday, Wednesday, Thursday
10 or A: Any day, Monday through Friday	23 or U: 1/2 Monday, Wednesday	33: 1/6 Monday through Saturday
11 or B: Any day, Monday through Saturday	24: 1/2 Monday, Thursday	34: 1/7 Monday through Sunday

Max Order Qty. Enter the maximum quantity to be received before warning messages display when you access the order line. If greater than 0 (zero), all maintenance, inquiry, and update programs display warning messages when the cumulative quantity received is equal to or exceeds this quantity.

Std Pack Qty. Enter the multiple in which orders for this item are shipped. This is similar to Order Multiple in the item master. It displays here because the standard shipment multiple for an item can vary among suppliers. Schedule Update from MRP rounds order quantities up to this multiple.

Order Multiple should generally be blank in the item master for items that are referenced on scheduled orders, since both values are applied to orders during different planning functions (MRP and Schedule Update from MRP).

Cum Start. Enter the date on which this order began to accumulate quantities. This may or may not be the date on which the order was created in your database.

When a line item is first scheduled, the cumulative receipt quantity is zero and the cumulative start date is set to the active start date of the schedule. As receipts are processed, the system updates the cumulative receipt quantity.

Sometimes cumulative receipt quantities must be adjusted manually, usually as dictated by policy. For example, you may reset them to zero at the start of your new fiscal year using Cum Received Reset to Zero (5.5.5.14). The affected cumulative start dates are then changed to that date.

See “Resetting Cumulative Quantities” on page 115 for details.

You can also adjust cumulative receipts manually to reflect returned or defective items or losses due to theft using Cumulative Received Maintenance (5.5.5.13). For example, when defective items are returned to the supplier, you may want to process a return and credit without decreasing cumulative quantity.

See “Cumulative Received Maintenance” on page 115 for details.

Start Effective. Enter the start effective date of this order line item or accept the default. The default is the:

- System date, if the header start effective date is earlier than or the same as the system date
- Header start effective date, if the header start effective date is later than the system date

The date cannot be blank and must within the range specified by the header.

End Effective. Enter the end effective date of this order line item, leave blank, or accept the default header End Effective date. If blank, there is no expiration for this line item. If you enter a date, it must be:

- The same as or later than the line start date
- Before the header end date if it is a new line

The system displays a warning if you change the end effective date and firm scheduled quantities exist outside of the date.

Note The system automatically sets the firm quantities to zero the next time you run Schedule Update from MRP (5.5.3.1) if you enter a line end effective date that is earlier than the previous date. If this is your intention, you should notify suppliers who are committed to the schedule of schedule cancellation of the firm quantities.

The end effective date displays on reports and inquiries.

Allocating Percentages for MRP

After you set up all suppliers and schedules for each item, you must allocate order percentages among suppliers. This step is required. Use Scheduled Order MRP % Maint (5.5.1.17) to allocate order percentages for non-subcontract orders; see Figure 4.7. Use Subcontract Order MRP % Maint (5.5.1.21) to allocate order percentages for subcontract orders. Percentages must equal 100% for each item or be 0 %.

For details on subcontract orders, see *QAD Manufacturing User Guide*.

Schedule Update from MRP uses these percentages to allocate MRP planned orders for the item among suppliers. To phase in new percentages, enter the same ship-to site and item number with different effective dates.

You must set the scheduled order MRP % allocation record or the subcontract order MRP % allocation record effective date within the scheduled order effective date range. Enter the MRP % effective date in the Effective field in the header, then select orders with a:

- Start effective date that is after the MRP % effective date
- End effective date that is before the MRP % effective date

See “Effective Dates” on page 97.

Note Orders with a 0% allocation do not have to fall within this date range.

The system displays the line end effective date in the End Effective field in the Purchase Order Percents frame. This date indicates when the scheduled order line is no longer active.

You can modify the percentage or remove a record if the end effective date is earlier than the system date and the order is closed as long as remaining records equal 100% for each item or are 0%.

Fig. 4.7
Scheduled Order
MRP % Maint (5.5.1.17)

The screenshot shows a software window titled "Scheduled Order MRP % Maint". At the top, it displays "Scheduled Order MRP % Maint: Go To - ACTIONS -". Below this, there are fields for "Ship-To Site: 10000", "Item Number: 20005", and "Effective: 05/02/2007". A section titled "Purchase Order Percents" contains a table with the following data:

Order	Percent	Line	End Effective
PO1121	0		

Processing Supplier Schedules

Processing schedules involves three major steps:

- 1 Creating a release of the schedule.
- 2 Optionally, modifying it.
- 3 Transmitting it to the supplier by print, EDI eCommerce, or fax.

Creating a Schedule Release

Use Schedule Update from MRP (5.5.3.1) to create releases of supplier schedules. A release is a set of item quantities and requirement dates identified by a release ID number, which is then sent to your supplier.

Schedule Update from MRP generates releases based on the following:

- Planned purchase orders generated by MRP based on item requirements and due dates
- Item planning data, such as safety days
- Scheduled order percentages defined for items and ship-to sites in Scheduled Order MRP % Maint (5.5.1.17) or Subcontract Order MRP Maint (5.5.1.21)
- Scheduled order data from Supplier Scheduled Order Maintenance (5.5.1.13)
- Supplier calendars, defined in Supplier Calendar Maintenance (5.5.1.1)

Note MRP planned orders for a co-product/by-product or a base process item cannot be used to update supplier schedules.

You can run Schedule Update from MRP for combinations of items, suppliers, scheduled orders, receiving sites, or buyers.

Because you are sending order quantities and planning data to your supplier, you define requirements as either firm or planned quantities. You can send all firm, all planned, or some of both. The Firm Days field on the scheduled order line item determines the order status.

You can also export the firm or planned portions of schedules (or both parts) to an external application using Schedule Update from MRP. Or you can use Export MRP Demand (5.5.3.2) to export planned and firm schedules directly from Schedule Update from MRP.

Note This export is not the same as the export done using functions on the EDI eCommerce menu. Export MRP Demand creates business object documents (BODs).

Fig. 4.8
Schedule Update from MRP (5.5.3.1)

Effect of Firm Days

The schedule update process automatically applies firm status to any requirements within the time fence set by the Firm Days field. All planned orders outside this period are approved, but maintained as planned requirements. This means that they are not seen by MRP as sources of supply and can be replanned.

Any unreceived firm requirements from one release are automatically carried forward to the next release during schedule update. These quantities are maintained as a prior cumulative requirement.

When you run MRP again, it plans or replans orders for scheduled requirements that are now within its planning horizon. Executing Schedule Update from MRP adds the planned orders, firming any that now fall within the Firm Days period.

If requirements change, you may need to manually adjust the firm quantities in Schedule Maintenance (5.5.3.3).

- If increased demands create additional requirements within the Firm Days period, MRP creates planned orders in that period. When you regenerate the schedule, the system does not select any planned orders falling within the firm period covered by a schedule. The warning message `Order not selected` displays.
- If requirements decrease due to decreased demands, MRP sees the supply as excessive and produces action messages.

You can avoid rescheduling problems due to fluctuations in short-term MRP data by setting Firm Days to zero on scheduled order lines. When Firm Days is zero:

- Firm requirements are not generated or carried forward from one release to the next.
- The system sets Prior Cum Req equal to Prior Cum Received.
- Each schedule release is based on the most recent MRP planned-order data available.

Use a positive number in the field if you have an agreement with this supplier that requirements will not change within a specified time period.

Important To avoid schedule discrepancies between printed bucketed schedules and the actual required schedule, firm days should never exceed the number of days specified in the Schedule Days field.

Schedule Adjustment for Work Days

On receipt of your scheduled release, the supplier is responsible for recalculating its own plans. If, as a customer, you do not set up a supplier calendar, or if you use a ship/delivery pattern that permits shipments on any day of the week, your schedule update process may create requirements on days when you or the supplier are closed.

The supplier would then reschedule the quantity requirement to the next earlier date when the supplier is open and you are open to receive it.

Quantity and Date Calculations

Schedule Update from MRP performs the following calculations:

- 1 Back-schedule for safety days from planned order due dates.
- 2 Back-schedule for Ship/Delivery Pattern from safety day schedule.
- 3 Back-schedule for Supplier Calendar from ship/delivery schedule.
- 4 Allocate planned order quantities by percentage to this supplier (from Scheduled Order MRP% Maintenance) to create new quantities by planned order.

- 5 Revise quantities to Standard Pack Quantity multiple.
- 6 Display any unfulfilled prior cumulative requirements.
- 7 Create release, assigning a Release ID, and determine whether quantities are firm (within the Firm Days time fence) or planned. See “Generate Date Based Release ID” on page 99.
- 8 Display fabrication and raw authorization quantities and start and end dates.

With the Report Detail/Summary field set to Detail, an audit report of the entire calculation is printed. Execute the function with Update set to No to preview the results.

When Update is Yes, selected planned orders are automatically approved and a release is created. This can then be edited in Schedule Maintenance or sent to your supplier.

Modifying Supplier Schedules

Modify a scheduled release using Schedule Maintenance (5.5.3.3).

You can change schedule detail data such as requirement dates, quantities, and firm or planned status, and fab and raw authorization quantities and dates.

You cannot update a schedule release if the scheduled receipt date is outside of the scheduled order line effective date range. Scheduled orders have both header and line start and end effective dates. When processing the order, the system uses the line start date and the later of the header or line end date as the active order line date range.

See “Effective Dates” on page 97.

Transmitting Supplier Schedules

Transmit the scheduled release using:

- Schedule Print (5.5.3.8), which lets you print a hard copy of the schedule to send to your supplier. For a schedule to be selected for printing, Print Schedules must be Yes in Supplier Scheduled Order Maintenance (5.5.1.13). This field defaults to Yes on new orders.

Schedule Print creates the printed supplier schedule. In the header of this document, the supplier and ship-to information, the release ID, purchase order number, item number, receipt quantity, and cumulative receipts appear. The ship/delivery pattern displays, then the order detail. The detail shows any prior open quantities, including quantities in transit, and then each scheduled requirement.

You specify whether the system uses calendar or working schedules to interpret firm days in the Calendar/Working Firm Days field in Schedule Update from MRP. The system uses the value of this field when printing schedule firm days. If you specify working schedules, the system treats holidays as nonworking days when the supplier schedule is calculated with working firm days.

- Schedule Print in Fax Format (5.5.3.9), which formats the schedule for facsimile transmission. For a schedule to be selected by this program, Fax Schedules must be Yes in Supplier Scheduled Order Maintenance. This field defaults to No on new orders.

When you transmit the scheduled release by fax, the orders are sorted by supplier rather than by site/supplier. At the top of the first schedule for each supplier, a pound sign (#) prints, followed by the supplier's fax number. The remainder of the information is the same as Schedule Print.

- Supplier Shipping Schedule (35.4.8), which exports the schedule in an EDI format that can be imported into the supplier's system. You can export a schedule only when EDI Schedules is Yes in Supplier Scheduled Order Maintenance. Define defaults for each supplier in Trading Partner Parameter Maintenance (35.13.10). See *QAD EDI eCommerce User Guide* for information on trading partner setup.

Schedule Bucketing

Scheduled requirements are maintained as discrete dates and quantities in the database. When you print or transmit a scheduled release, the system uses the Schedule Days, Schedule Weeks, and Schedule Months field values to bucket requirements for the supplier.

Fig. 4.9
Schedule Bucketing

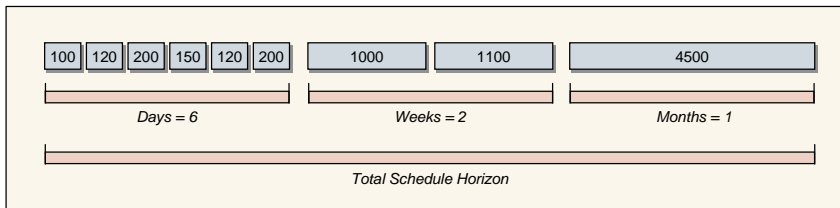

In Figure 4.9, all requirements within the next six days display in discrete quantities on discrete dates including any intraday requirements and times.

Requirements in the two weeks following daily requirements are bucketed into one quantity per week with a delivery date of the Monday of that week. Ship dates, if you use Transport Days, are back-scheduled from that Monday. Monthly requirements beyond the weekly period are bucketed in the first Monday of the month.

On the printed schedule:

- Req Qty is the discrete or bucketed quantity for that schedule line.
- Cum Req Qty is the total cumulative requirement, including that line quantity, for the entire life of the order.
- Net Req Qty is the total open quantity including that line quantity.

Receiving Scheduled Orders

Receipts against a scheduled order have several possible stages. How a relationship is arranged is a matter of policy between trading partners. You can use these tools and capabilities to support any receiving relationship between you and your supplier. The primary tools are the various shipment documents.

There are four documents. Each one can be treated as a separate document, or in some cases, one document can serve the function of all four.

Advance Ship Notice (ASN). The ASN is transmitted when a shipment leaves the supplier's shipping dock to provide advance notice of items to be received. This document can represent multiple items over multiple orders.

Receiving Document. This printed packing list accompanies the shipment, recording quantities and items, identified by a shipper ID.

Shipment Labels. Barcode labels can be affixed to each shipment container and container group. All items, including container items, explode into inventory during barcode reader receiving. See "PO Container Maintenance" on page 114.

Invoices. The invoice lists quantity and item detail by order, with extended pricing.

In some relationships, the ASN is the only document transmitted. It is treated as the receiving document and the invoice. The ASN number becomes the shipper number and the invoice number, referenced on payments.

Once you have determined how shipments from your suppliers are to be documented, you can process receipts. Recording a receipt updates three history records:

- Purchase receipts
- Inventory transactions
- Inventory GL costs

These records are used for accounts payable, variance reporting, and supplier performance reports. If you receive deliveries from more than one supplier on the same day for the same order, you should enter separate receipts to simplify management in accounts payable.

Note The receipt of a memo item on a scheduled order produces GL transactions with the same accounts as those produced for a memo item on a discrete purchase order.

Depending on the documents involved, you use different programs.

- If you need to manually enter receipts or confirm them, use PO Shipper Maintenance (5.5.5.5) first. You can also receive scheduled orders with Purchase Order Receipts (5.13.1).
- If you typically accept the ASN or receiving document without verification, simply confirm the receipt with PO Shipper Receipt (5.5.5.11).
- If you need to modify container quantities, use PO Container Maintenance (5.5.5.4).
- If you need to modify item quantities on a confirmed shipper, use Cumulative Received Maintenance (5.5.5.13).

You cannot create receipts when the transaction date is outside the order line effective date range for the scheduled order line being received. You can return items, but a warning displays when the transaction date is outside of the order line effective date range, and you are prompted to continue. The system displays a warning in the following receipt programs:

- PO Shipper Maintenance (5.5.5.5)
- PO Shipper Receipt (5.5.5.11)
- Purchase Order Receipt (5.13.1)
- PO Container Maintenance (5.5.5.13)

See "Effective Dates" on page 97.

PO Shipper Maintenance

Enter the shipment ID using PO Shipper Maintenance. The shipment ID can be an ASN number already in the system, a number obtained through a barcode reading of a shipping label, or a number entered manually from the receiving document.

You can enter each container in the shipment, or click End to skip the Container entry screen. Enter shipped quantities by item number, purchase order, purchase order line number, and quantity in the next frame. Use PO Container Maintenance to modify container item quantities if necessary.

Click Next to accept the first item and quantity, and continue entering items for the shipment.

Note You can modify shippers that have already been confirmed. However, you cannot reconfirm modified shippers.

PO Shipper Receipt

Confirm the shipment using PO Shipper Receipt. If the tolerance for a discrete order receipt is exceeded, the system displays a warning. Confirmation increases inventory, increases the cumulative received quantities, decreases net cumulative requirements, and updates AP and GL accounts.

When you confirm the shipper, the cumulative totals and net requirements are properly updated and automatically transmitted to the supplier on the next scheduled release.

PO Shipper Receipt and Purchase Order Receipt (5.13.1) consider the setting of the Fixed Price field when determining whether a new PO price should be looked up during receipt of a scheduled order with a discount table.

See “Fixed Price” on page 104.

Purchase Order Receipts

If you are not receiving ASNs or reading barcode labels and exploding containerized shipments, you can also enter receipts against supplier schedules in Purchase Order Receipts.

More than one line item can be processed in a single transaction. You can correct errors made in receiving by entering negative quantities. However, you may have to reopen a purchase order line to do this. Several settings in Purchasing Control (5.24) determine how receiving documents are entered and printed.

If the cumulative quantity received for a scheduled order line exceeds the maximum order quantity for that line, the system displays a warning message.

PO Container Maintenance

A container is a subset of a shipper, holding any number of different items or other containers. You can receive container information electronically as a part of an ASN or the information may arrive with the shipment and be entered manually. Container information may also explode into the system from barcode readings of shipping labels.

Containers conveniently group items, but are not a required part of a shipper. You can also receive items individually or the shipper as a whole.

Containers are not often a concern with supplier schedules. However, you can track them for lot/serial control. If the actual shipment does not match the shipper, fix the quantities in PO Shipper Maintenance or PO Container Maintenance (5.13.13) before confirming the shipper.

Note To return containers that have been explicitly received on a shipper, use Issues–Unplanned (3.7).

Cumulative Received Maintenance

You may need to increase or decrease item quantities on a confirmed shipper. Do this with Cumulative Received Maintenance (5.5.5.13) using the Adjust option. The new cumulative quantity is then transmitted on the next scheduled release. You can also reset the entire scheduled order back to a zero quantity with a new Cum Start Date.

This program is typically not used often and should be restricted with menu security. If a discrepancy between cumulative customer receipts and your cumulative shipped quantities occurs, this is accommodated in the process of making a scheduled release active. However, the Adjust option can be useful for a discrepancy adjustment that occurs solely on your end of the trading relationship, such as the addition or removal of items after shipper confirmation and before ASN export.

Resetting Cumulative Quantities

Use Cum Received Reset to Zero (5.5.5.14) to reset the cumulative totals for scheduled orders and generate a report showing which orders were reset. You can reset one or a range of scheduled orders. Select scheduled orders for reset using order number, item number, supplier, ship-to, or buyer.

Fig. 4.10
Cum Received Reset to Zero (5.5.5.14)

You can run the cumulative reset function without actually resetting a scheduled order's cumulative totals. This gives you an opportunity to review the scheduled orders being reset before actually changing the database. Do this by setting Update to No. When Update is Yes, the cumulative totals are reset. This action cannot be undone.

When you reset the totals, you can also enter a new cum shipped start date. This new date replaces the order's current cum start date specified in Supplier Scheduled Order Maintenance (5.5.1.13).

Typically, you reset cumulative orders to zero when the contract related to the order is renegotiated. Scheduled order pricing is usually based on an agreed-upon total cumulative order quantity. When you renegotiate the price, you normally renegotiate a new total for the cumulative order quantity.

Deleting Supplier Scheduled Orders

You can use Closed PO Delete/Archive (5.23) to delete and archive scheduled orders that do not have an associated active or inactive schedule. This program works like other delete/archive programs in the system.

However, to ensure that all records associated with the scheduled order are also deleted, you must follow these steps:

- 1 Delete all releases for the supplier schedule in Schedule Maintenance (5.5.3.3).
- 2 Delete the MRP percentage in Scheduled Order MRP % Maint (5.5.1.17).
- 3 Delete the supplier scheduled order with Closed PO Delete/Archive (5.23).

If you delete or archive closed scheduled orders, an error displays if the order header end effective date:

- Is later than or the same as the system date
- Does not fall within the close date range you specify

This prevents the system from deleting or archiving scheduled orders that are still open.

See “Effective Dates” on page 97.

You cannot delete a system-created trade sales supplier scheduled order using system programs that delete or archive orders.

See Section 3, “Trade Sales,” beginning on page 159.

Supplier Shipping Schedules

This chapter describes how to set up and use features of the optional Supplier Shipping Schedules module.

Introduction to Supplier Shipping Schedules 118

Introduces new features added by the Supplier Shipping Schedules module.

Setting Up Supplier Schedules 121

Outlines how to set up supplier shipping schedules by setting up the correct base data, values, and supplier and shipping information.

Creating a Schedule Release from MRP 128

Describes how to use Schedule Update from MRP to create releases and the types of requirements and calculations that are involved.

Manually Updating a Schedule Release 132

Explains how to modify schedules using Supplier Planning Schedule Maint or Supplier Shipping Schedule Maint.

Transmitting Supplier Schedules 134

Describes how to transmit schedule releases using Supplier Shipping Schedule, Schedule Print, and Schedule Print in Fax Format.

Reviewing and Comparing Releases 137

Explains how optional modules can update review and comparison reports for viewing and analyzing releases.

Deleting and Archiving Schedules 140

Describes how Schedule Delete/Archive can be used to delete and archive schedule releases.

Introduction to Supplier Shipping Schedules

The system supports one type of supplier schedule (type 4) that combines short-term and long-term requirements. The optional Supplier Shipping Schedules module lets you generate separate supplier planning and shipping schedules. To facilitate this, this module adds two additional supplier schedule types:

Type 5: Supplier Planning Schedules

Type 6: Supplier Shipping Schedules

Note This module does not affect customer schedule functions.

When the Supplier Shipping Schedules module is active, only supplier schedules of type 5 and 6 can be edited using maintenance programs. Standard supplier schedules (schedule type 4) continue to exist, but are maintained by the system.

Note Supplier Shipping Schedules is an element of the QAD PRO/PLUS functionality. Other PRO/PLUS elements include:

- AR Self-Billing; see *QAD Financials User Guide*
- Container and Line Charges; see *QAD Sales User Guide*
- Customer Sequence Schedules; see Chapter 3, “Customer Sequence Schedules,” on page 69 in this user guide
- Shipment Performance Reporting; see *QAD Sales User Guide*
- Supplier Performance; see *QAD Purchasing User Guide*

Trade Sales Supplier Shipping and Planning Schedules

See Section 3, “Trade Sales,” beginning on page 159.

You create customer trade sales orders in Customer Scheduled Order Maintenance (7.3.13) using optional trade sales functionality. The system automatically creates supplier scheduled orders that it links to the trade sales order. The system also automatically creates a trade sales supplier shipping schedule when you:

- Import a trade sales customer shipping schedule.
- Modify an existing active customer shipping schedule in Customer Ship Schedule Maintenance (7.5.2).
- Reactivate a currently inactive trade sales customer shipping schedule in Customer Ship Schedule Maintenance.

The system also automatically creates a trade sales supplier planning schedule when you:

- Import a trade sales customer planning schedule.
- Modify an existing active customer planning schedule in Customer Plan Schedule Maintenance (7.5.1).
- Reactivate a currently inactive trade sales schedule in Customer Plan Schedule Maintenance.

See Section 3, “Trade Sales,” beginning on page 159.

You view or edit the details of these system-created supplier scheduled orders in Supplier Scheduled Order Maint only when Edit Trade Sales Orders is Yes in Supplier Shipping Sched Control. You can enter the trade sales PO number in the reports and inquiries in the Schedule Processing Menu to view or print supplier shipping or planning schedules.

EDI eCommerce can automatically export supplier shipping or planning schedules to trade sales suppliers depending on Trading Partner Parameter Maintenance (35.13.10) and eCommerce Manager (35.5) settings.

See *QAD EDI eCommerce User Guide*.

Types of Purchase Orders

Table 5.1 contrasts the characteristics of optional supplier schedules with other kinds of purchase orders.

Table 5.1
Summary of Purchase Order Characteristics

	Supplier Shipping Schedules	Supplier Planning Schedules	Supplier Schedules	Purchase Orders	Blanket Orders
Delivery Dates	Multiple	Multiple	Multiple	Single for order/item	Multiple
Delivery Times	Multiple—System-Generated	Multiple—Entered Manually	Multiple—Entered Manually	No	No
Seen by MRP	Indirectly, through type 4 schedule	Indirectly, through type 4 schedule	Yes	Yes	No
Receipts	Yes	Yes	Yes	Yes	No
Duration	Short- and Medium-Term	Medium- and Long-Term	Short-, Medium-, and Long-Term	One-Time	Short- and Medium-term
Elements	Header Shipping Schedule Trailer	Header Planning Schedule Trailer	Header Planning Schedule Shipping Schedule Trailer	Header Line Items Trailer	Header Line Items Trailer POs

Supplier Schedules Example

A manufacturer of circuit boards needs blank boards supplied on each day of the week. The manufacturer knows the exact quantities they require for the next few days, can estimate their requirements for the next few weeks, and knows the approximate requirements for the next 12 months.

The supplier of these circuit board blanks uses the planning information provided by the manufacturer to place its orders for raw materials and to plan production. It can use planning schedules to help define its delivery and planning schedules and shipping schedules to schedule the day-to-day deliveries required by the circuit board manufacturer.

The same manufacturer also needs to order the solder used to weld circuits to the board. Since the solder is sold in bulk quantities and a large supply is always on hand, the manufacturer does not generate shipping schedules for it. Instead, a planning schedule for solder requirements is generated for the next twelve months. The planning schedule indicates that solder should be delivered only once per week.

Menu Listing

The optional Supplier Shipping Schedules module (5.5.7) is on the Supplier Schedules menu (5.5).

Table 5.2 lists programs that are a part of the optional Supplier Shipping Schedules module.

Table 5.2
Optional Supplier Shipping Schedules

Menu Number	Description	Program Name
5.5.7.1	Ship Delivery Time Maintenance	rssdtmt.p
5.5.7.2	Ship Delivery Time Inquiry	rssdtiq.p
5.5.7.4	Supplier Controls Maintenance	adssmt.p
5.5.7.6	Supplier Planning Schedule Maint	rpsmt.p
5.5.7.7	Supplier Shipping Schedule Maint	rssmt.p
5.5.7.13	Ship Schedule Variance Compare	rsrp10.p
5.5.7.14	Ship to Plan Schedule Compare	rsrp11.p
5.5.7.24	Supplier Shipping Schedule Control	rspm.p

When you activate this module, new features are added to some existing programs, and Schedule Maintenance (5.5.3.3) cannot be used to maintain schedules. The added features help to create, process, export, and report data for supplier shipping and planning schedules.

When you deactivate the Supplier Shipping Schedules module, the modified programs operate as they did before, and Schedule Maintenance can be used to modify type 4 schedules. When Supplier Shipping Schedules is inactive, you cannot update supplier schedules of type 5 or 6.

For information on how to activate Supplier Shipping Schedules, see page 121.

Programs modified by Supplier Shipping Schedules are listed in Table 5.3.

Table 5.3
Optional Supplier Shipping Schedules, Modified Programs

Menu Number	Description	Program Name
5.5.1.13	Supplier Scheduled Order Maintenance	rspomt.p
5.5.3.1	Schedule Update from MRP	rssup.p
5.5.3.3	Schedule Maintenance	rssmt.p
5.5.3.4	Schedule Inquiry	rsiq01.p
5.5.3.5	Schedule History Inquiry	rsiq02.p
5.5.3.8	Schedule Print	rsrp05.p
5.5.3.9	Schedule Print in Fax Format	rsrp09.p
5.5.3.13	Schedule Report	rsrp01.p
5.5.3.15	Schedule Comparative	rsrp02.p
5.5.3.17	Schedule Authorization Report	rsrp03.p

Menu Number	Description	Program Name
5.5.3.23	Schedule Delete/Archive	rsdel.p
35.4.8	Supplier Shipping Schedule	edomsch.p

Setting Up Supplier Schedules

To use supplier shipping and planning schedules, you must set up the same base data required for purchase orders, including purchased items and supplier addresses. In addition, to automatically generate schedules based on item requirements from MRP, you must set up the base data and parameter values required by MRP, including item planning data.

For information on setting up and running MRP, see *QAD Manufacturing User Guide*.

Figure 5.1 illustrates a typical workflow for setting up the additional schedule-related data required to use supplier planning and shipping schedules. Each of these steps is discussed in detail in the following sections.

Fig. 5.1
Supplier Schedules Setup Flow

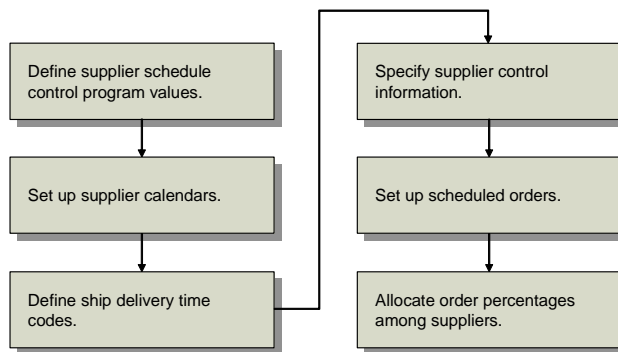

Setting Control Program Values

Use settings in Supplier Shipping Schedule Control (5.5.7.24) to activate the optional Supplier Shipping Schedules module and define generic default values for scheduled orders and generated schedules.

Many of the field values in Supplier Shipping Schedule Control default to corresponding fields in Supplier Controls Maintenance (5.5.7.4). The control program values also default to scheduled orders for suppliers that do not have supplier-specific defaults. You can modify the defaults you define here as needed for individual suppliers and scheduled orders.

See “Defining Scheduled Order Defaults for Specific Suppliers” on page 124.

Fig. 5.2
Supplier Shipping Schedule Control (5.5.7.24)

Enable Shipping Schedule. Enter Yes to activate the Supplier Shipping Schedules module.

Note When this value is Yes, you cannot manually update standard supplier schedules (type 4).

Generate Ship Schedule From MRP, Firm Days, Schedule Days, Schedule Weeks, Schedule Months, Fab Auth Days, Raw Auth Days. These fields set the default values for their corresponding fields in Supplier Controls Maintenance. In addition, they default to corresponding fields in scheduled orders created for suppliers that do not have supplier-specific defaults set up in Supplier Controls Maintenance (5.5.7.4).

See “Scheduled Orders” on page 125.

Auto Update Plan From Ship. This field indicates whether planning schedules are automatically updated by the system when you make manual changes to their associated shipping schedules.

No: Planning schedules are not updated when their associated shipping schedules are changed.

Yes: When a requirement on a shipping schedule is manually changed, the requirement on the associated planning schedule for the active release ID is automatically updated.

Automatic update occurs only when the shipping and planning schedules have the same release ID and have not been sent to the supplier.

Entering Yes ensures that the requirements in the two schedules always correspond.

Example On a typical Monday, you generate both a planning schedule for weeks and months and a shipping schedule for the next one or two weeks. One of your customers sends a rush order, and you must adjust the shipping schedule. As a result, the current shipping schedule no longer corresponds to the planning schedule. When Auto Update Plan From Ship is Yes, the system automatically updates your planning schedule with the changes you made to the shipping schedule.

Send Zero Requirements. This field sets the default value for the corresponding field in Supplier Controls Maintenance.

Edit Trade Sales Orders. Enter Yes to allow Supplier Scheduled Order Maintenance to be used to update orders that were created in Trade Sales. The system displays a message that it is a Trade Sales order and prompts you to continue before entering edit mode.

When this field is No, you cannot directly update Trade Sales supplier scheduled orders.

Regardless of this setting, you cannot delete a Trade Sales order using Supplier Scheduled Order Maintenance.

Setting Up Supplier Calendars

If your supplier works different days than you do, set up a supplier-specific calendar for them in Supplier Calendar Maintenance (5.5.1.1). Schedule Update from MRP considers these calendars when generating schedule releases. For suppliers that do not have supplier-specific calendars, the system uses the applicable shop calendar. For information on setting up supplier and shop calendars, see *QAD System Administration User Guide*.

See “Quantity and Date Calculations” on page 130.

Defining Ship Delivery Time (SDT) Codes

Use Ship Delivery Time Maintenance (5.5.7.1) to define ship delivery time (SDT) codes and associate one or more delivery times with them

SDT codes specify exact delivery times on supplier shipping schedules. Daily item requirements are divided into hour and minute buckets based on these delivery times.

Note SDT codes are not used on supplier planning schedules. You can specify an interval code, as needed.

Associate SDT codes with individual scheduled orders to avoid having to manually enter delivery times on supplier shipping schedules. You can also use Supplier Controls Maintenance (5.5.7.4) to associate default SDT codes with individual suppliers. Schedule Update from MRP (5.5.3.1) uses the delivery times associated with SDT codes on scheduled orders to bucket daily item requirements on supplier shipping schedules.

See “Requirement Bucketing” on page 129.

Residual quantities from multiple deliveries are always added to the first delivery of the day. Also, pack quantities are not split. For example, if an item is delivered in lots of 50 and your delivery time buckets indicate that 25 items should be delivered in the morning and 25 in the afternoon, the standard lot of 50 is planned for the morning delivery.

See “Quantity and Date Calculations” on page 130.

Use Ship Delivery Time Inquiry (5.5.7.2) to review SDT codes and their associated delivery times.

Fig. 5.3
Ship Delivery Time Maintenance (5.5.7.1)

Ship Delivery Time Code. Specify a one- to three-character identifier for this SDT code.

SDT Description. Optionally enter a description for this SDT code.

Click Next to proceed to the next frame. When you are modifying an existing SDT code, this frame displays the delivery times already associated with the SDT code. To associate delivery times with an SDT code, press Insert in this frame and specify a new delivery time in the Time field that displays.

Fig. 5.4
Ship Delivery Time Maintenance, Second Frame

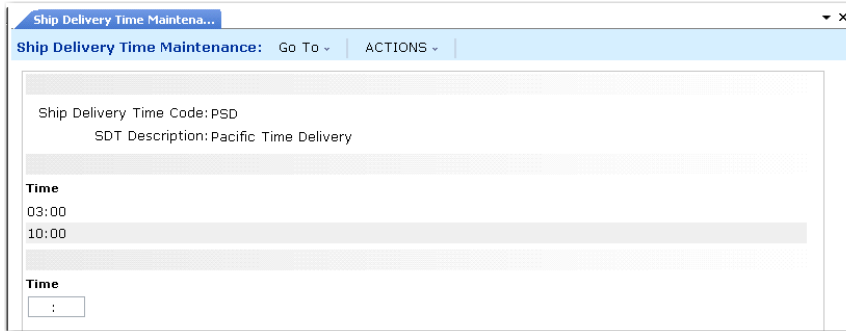

Time. Specify a delivery time to associate with this SDT code using the 24-hour time format. For example, 9:00 AM is 09:00, 3:00 PM is 15:00, and 9:00 PM is 21:00.

In the example shown in Figure 5.4, for supplier shipping schedules with SDT code 02, you expect deliveries to be made twice per day, once at 8:00 AM and once at 2:00 PM.

Defining Scheduled Order Defaults for Specific Suppliers

Use Supplier Controls Maintenance (5.5.7.4) to define scheduled order defaults for individual suppliers. Most of the values you enter here default to fields in the order line data frame of Supplier Scheduled Order Maintenance (5.5.1.13).

You should define scheduled order defaults to avoid repetitive entry of the same supplier shipping and authorization information when creating scheduled orders. However, you only need to define supplier-specific control records for suppliers with special processing requirements. When you create a scheduled order for a supplier that does not have an associated set of defaults in Supplier Controls Maintenance, the system uses the default values defined in Supplier Schedule Control (5.5.7.24).

The Send Zero Requirements does not default to scheduled orders. This value indicates whether schedule detail lines with quantities of zero are included in schedules sent to the associated supplier.

Most of the field values in this program initially default from Supplier Shipping Schedule Control.

See “Setting Control Program Values” on page 121.

Fig. 5.5.
Supplier Controls Maintenance (5.5.7.4)

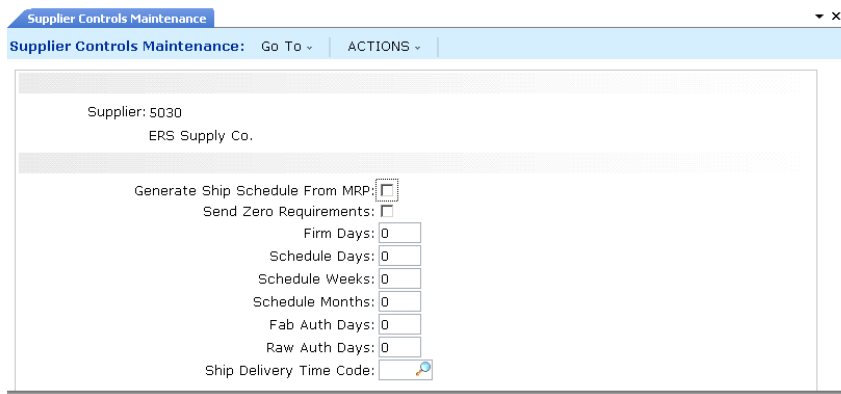

Generate Ship Schedule From MRP. This value indicates whether you typically generate shipping schedules for this supplier based on item requirement data from MRP. It sets the default for the corresponding field on scheduled orders created for this supplier.

Firm Days, Schedule Days, Schedule Weeks, Schedule Months, Fab Auth Days, Raw Auth Days, Ship Delivery Time Code. These fields set the default values for their corresponding fields in Supplier Scheduled Order Maintenance (5.5.1.13) when a scheduled order is created for this supplier.

Scheduled Orders

Use Supplier Scheduled Order Maintenance (5.5.1.13) to set up scheduled orders. Scheduled orders define the parameters used to generate planning and shipping schedules for individual items that have been entered on separate scheduled order lines. They provide the framework for a shipping contract between customer and supplier, but have no delivery dates. When you run Schedule Update from MRP, the system uses item demand data from MRP to create planning and shipping schedules for scheduled order line items.

See “Creating Scheduled Orders” on page 100.

Table 5.4 lists Supplier Scheduled Order Maintenance fields that play a role in supplier shipping or planning schedules. Most of these fields default from Supplier Controls Maintenance if a supplier record exists; otherwise, they default from Supplier Schedule Control.

Table 5.4
Supplier Shipping Fields in Supplier Scheduled Order Maintenance

Field	Importance to Supplier Shipping Schedules
Print Schedules, EDI Schedules, Fax Schedules	Use these fields to specify how generated shipping or planning schedules for the order will be delivered to suppliers.
Firm Days	For supplier shipping schedules, quantities and dates within the period you specify in this field are not changed by Schedule Update from MRP.

Field	Importance to Supplier Shipping Schedules
Schedule Days, Schedule Weeks, Schedule Months	<p>Schedule Update from MRP uses these values to determine the number of days, weeks, and months that display on schedules based on this order line. Shipping schedules are generated for the number of days specified in the Schedule Days field for this line. Planning schedules are generated to cover the sum of schedule weeks and schedule months.</p> <p>When Schedule Days is zero on an order line, supplier shipping schedules are not generated for that line. When both Schedule Weeks and Schedule Months are zero for an order line, supplier planning schedules are not generated for that line.</p>
Fab Auth Days, Raw Auth Days	<p>These fields indicate the number of days the system uses to calculate fabrication authorization quantities (fab quantities) and raw authorization quantities (raw quantities) on supplier planning schedules. The values you specify here are called <i>authorization horizons</i>.</p> <p>Fab and raw quantities represent cumulative item requirements within the specified number of days since the active start date of their associated planning schedules. These data are sent to the supplier as part of the planning schedule.</p> <p>Schedule Update from MRP uses these values only if scheduled requirements extend beyond the number of days in the authorization horizon. Otherwise, authorization horizons are equal to the number of schedule days specified on the applicable scheduled order line.</p>
Ship Delivery Pattern Code	Use this field to enter an industry-defined code that indicates the days of the week or month that a supplier is open to make shipments
Std Pack Qty	This is the multiple in which orders for this item are shipped. It displays because the standard shipment multiple for an item can vary among suppliers. Schedule Update from MRP rounds order quantities up to this multiple.

Shipping Schedule Info Pop-Up

After the second order line item data frame in Supplier Scheduled Order Maintenance, the Shipping Schedule Info pop-up displays when the Supplier Shipping Schedules module is active. Values in this pop-up default from the corresponding fields in Supplier Controls Maintenance (5.5.7.4) when values have been defined for the supplier on the order. Otherwise, they default from Supplier Shipping Schedule Control (5.5.7.24).

Fig. 5.6
Shipping Schedule Info Pop-Up

The screenshot shows a software window titled 'Supplier Scheduled Order Maint'. At the top, it displays 'Purchase Order: P1121' and 'Supplier: 5000'. Below this, there's a section for 'Order Line Item Data' with various input fields: Firm Days (5), Schedule Days (0), Schedule Weeks (7), Schedule Months (dropdown), Fab Auth Days, Raw Auth Days, Transport Days (0), Safety Days (0.00), Supplier Item, and Container Item. A 'Shipping Schedule Info' pop-up window is open over the 'Schedule Weeks' field. This pop-up contains a checked checkbox for 'Generate Ship Schedule From MRP', a 'Ship Delivery Time Code' field, and 'Start Effective' (05/02/2007) and 'End Effective' (dropdown) date fields.

This pop-up displays when Supplier Shipping Schedules is active.

Generate Ship Schedule From MRP. This field indicates whether you generate supplier shipping schedules based on this order line. See “Creating a Schedule Release from MRP” on page 128.

Important To generate a shipping schedule for a scheduled order line, Schedule Days must have a nonzero value for that line.

No: Only planning schedules are generated for this line.

Yes: When you run Schedule Update from MRP (5.5.3.1) with Generate Shipping Schedules set to Yes, a supplier shipping schedule is generated for this line. This shipping schedule covers item requirements for the specified number of schedule days.

Note When you run Schedule Update from MRP with Generate Shipping Schedules set to No, shipping schedules are not generated for any scheduled order lines, regardless of how this field is set.

Ship Delivery Time Code. Enter the SDT code for Schedule Update from MRP to use to calculate exact delivery times on supplier shipping schedules. See page 123.

Allocating Percentages for MRP

After you have set up the required supplier data and scheduled orders for each item, you must allocate order percentages among suppliers using Scheduled Order MRP % Maint (5.5.1.17). Total percentages for each item must equal 100%.

Schedule Update from MRP (5.5.3.1) uses the percentages you define for an item to allocate MRP planned orders for that item among suppliers.

See “Quantity and Date Calculations” on page 130.

Creating a Schedule Release from MRP

Use Schedule Update from MRP (5.5.3.1) to create releases of supplier schedules. A release is a set of item quantities (requirements) and requirement dates identified by a release ID number, which is then sent to your supplier. A single schedule release can include both planning and shipping schedules.

See “Creating a Schedule Release” on page 109.

Note MRP planned orders for a co-product/by-product or a base process item cannot be used to update supplier schedules.

Firm and Planned Requirements

On supplier schedules, item requirements can be either *firm* or *planned*. Requirements designated as firm are:

- Not replanned when Schedule Update from MRP is run
- Visible to MRP as scheduled supply, like discrete purchase orders

Requirements designated as planned are not considered sources of supply by MRP and may change when MRP is rerun. The schedules you send to suppliers can contain firm requirements only, planned requirements only, or a combination of both.

The schedule update process automatically applies a status of firm to item requirements that are:

- Within the number of firm days (firm interval) specified on the associated scheduled order line
- Within the schedule days specified on the scheduled order line

See page 125.

Schedule Update from MRP only designates shipping schedule requirements as firm. It does not designate item requirements on planning schedules as firm, even when planning schedule active dates are within the schedule firm interval. However, you can manually designate detail line quantities as firm on individual planning schedules, if required.

See “Manually Updating a Schedule Release” on page 132.

Any unreceived firm requirements from one release are automatically carried forward to the next release during schedule update. These quantities are maintained as a prior cumulative requirement.

Planned orders outside the firm days period are approved, but maintained as planned requirements. This means that they are not seen by MRP as sources of supply and can be replanned. When you rerun MRP, it plans or replans orders for scheduled requirements that are now within its planning horizon. Executing Schedule Update from MRP adds the new and updated planned orders, designating as firm any requirements that now fall within the Firm Days period.

If requirements change, you may need to manually adjust firm quantities in Supplier Shipping Schedule Maint (5.5.7.7) or Supplier Planning Schedule Maint (5.5.7.6).

- When increased demands create additional requirements within the Firm Days period, MRP creates planned orders in that period. When you regenerate the schedule, the system does not select any planned orders falling within the firm period covered by a schedule. The warning message `Order not selected` displays in the report.

- When requirements decrease due to decreased demands, MRP sees the supply as excessive and produces action messages.

See “Manually Updating a Schedule Release” on page 132.

You can avoid rescheduling problems due to fluctuations in short-term MRP data by setting Firm Days to zero on scheduled order lines. When Firm Days is zero:

- Firm requirements are not generated or carried forward from one release to the next.
- The system sets Prior Cum Req equal to Prior Cum Received.
- Each schedule release is based on the most recent MRP planned-order data available.

Use a positive number in the field if you have an agreement with this supplier that requirements will not change within a specified time period.

See “Firm Days” on page 104.

Important To avoid schedule discrepancies between printed bucketed schedules and the actual required schedule, firm days should never exceed the number of days specified in the Schedule Days field.

Requirement Bucketing

Item requirements on standard supplier schedules (type 4) are maintained as discrete dates and quantities in the database. The system does not bucket item requirements on these schedules until they are printed or transmitted to the supplier. Item requirements on supplier planning (type 5) and shipping schedules (type 6), however, are stored differently than those for type 4 schedules.

When Schedule Update from MRP generates a schedule release, it uses the Schedule Days, Schedule Weeks, and Schedule Months values defined for applicable scheduled order lines to:

- Determine the length of time covered by the item requirements in planning and shipping schedules.

Shipping schedules cover item requirements for the specified number of schedule days, while planning schedules cover requirements for the sum of schedule weeks and schedule months.

See “Schedule Days” on page 105.

- Bucket item quantities on planning and shipping schedules.

Requirement buckets display on planning and shipping schedules as schedule detail lines. On shipping schedules, daily requirements are further divided into hour and minute buckets based on the SDT code associated with the applicable order line.

See “Defining Ship Delivery Time (SDT) Codes” on page 123.

Planning schedule requirements for the number of schedule weeks and months specified on the applicable order line reside in discrete bucketed quantities, as shown in Figure 5.7.

Note When you generate only planning schedules, applicable schedule days requirements are also included on each planning schedule.

Fig. 5.7
Supplier Planning Schedule Bucketing

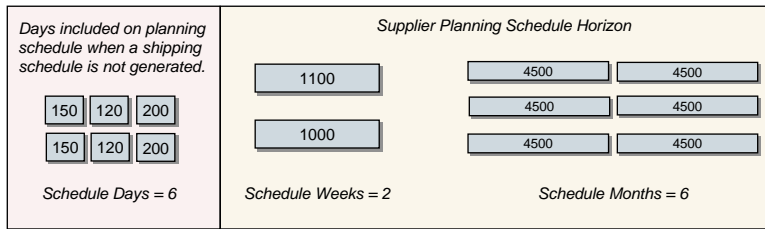

Schedule Update from MRP always assigns the entire quantity in each weekly requirement bucket to the first day of the week on which the supplier is available, based on the supplier calendar set up in Supplier Calendar Maintenance (5.5.1.1). For suppliers that do not have supplier-specific calendars, the standard shop calendar is used. For information on setting up supplier and shop calendars, see *QAD System Administration User Guide*.

When both Schedule Days and Schedule Weeks are positive on a scheduled order line, the number of daily buckets may extend beyond the number of schedule days defined on that line. This occurs so that the first schedule week will always begin on the first day the supplier is available.

Example A scheduled order, SCD 128, is created for supplier SUP886. For line 1 on this order, Schedule Days is 14 and Schedule Weeks is 4. Schedule Update from MRP is run with As-of Date set to 03/09/99, a Tuesday. The supplier calendar for SUP886 indicates that the first day of the week on which the supplier is available is Monday. So that weekly bucketing will start on a Monday, the system generates a shipping schedule covering 20 days rather than just 14.

For each monthly requirement bucket on a planning schedule, the system assigns the entire item quantity to the first Monday of the applicable month. When schedule weeks do not end on the last Sunday of the month, the number of weekly buckets on the planning schedule may extend beyond the number of schedule weeks specified for the applicable scheduled order line.

Shipping schedule requirements are stored in time buckets based on the SDT code for the number of schedule days indicated on the associated order line. An example is shown in Figure 5.8.

Fig. 5.8
Supplier Shipping Schedule Bucketing

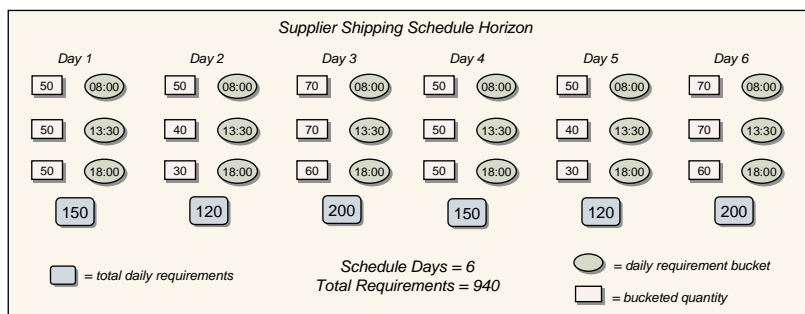

Quantity and Date Calculations

Schedule Update from MRP performs the following calculations:

- 1 Back-schedule for safety days from planned order due dates.
- 2 Back-schedule for ship/delivery pattern from safety day schedule. See page 125.

- 3 Back-schedule for supplier calendar from ship/delivery schedule. See page 123.
- 4 Allocate planned order quantities by percentage to each supplier based on Scheduled Order MRP % Maint (5.5.1.17) to create new quantities by planned order. See page 127.
- 5 Revise quantities to Std Pack Qty multiple. See page 125.
- 6 Display any unfulfilled prior cumulative requirements.
- 7 Create a release, assign a Release ID and determine whether quantities are firm (within the Firm Days time fence) or planned. See page 131.
- 8 Calculate fabrication and raw authorization quantities and start and end dates.
The start date is the active start date. The end date is calculated by adding the number of days specified in Raw Auth Days and Fab Auth Days to this date. The quantity requirements between the active start date and the calculated end date are the schedule quantities displayed on the shipping schedule.
See page 125.
- 9 Generate a shipping schedule containing daily requirements. When an SDT code is specified, bucket quantities into the ship delivery times for each day.
Shipping schedules are generated only when:
 - Scheduled days are specified in the scheduled order.
 - Generate Ship Schedules from MRP is Yes on the scheduled order line.
 - Generate Shipping Schedules is Yes in Schedule Update from MRP.
- 10 Allocate quantities using ship/delivery pattern.
- 11 Zero requirement schedules are sent to the supplier only when Send Zero Requirements is Yes in Supplier Controls Maintenance. See page 122.
- 12 Generate a planning schedule.
When you create a planning schedule but not the corresponding shipping schedule, the daily requirements display on the planning schedule as planned requirements. This only occurs when Schedule Days is greater than 1 on the applicable scheduled order line.

Release IDs

When Generate Date Based Release ID is Yes in Supplier Schedule Control (5.5.1.24), Schedule Update from MRP generates supplier schedule release IDs based on the date their associated schedules were created or updated.

See “Generate Date Based Release ID” on page 99.

Report Options

When Report Detail/Summary is set to Detail, an audit report of the entire calculation is printed. Execute the function with Update set to No to preview the results before generating any schedules.

When Update is Yes, selected planned orders are automatically approved and a release is created. The new release can then be modified in Supplier Planning Schedule Maint (5.5.7.6) or Supplier Shipping Schedule Maint (5.5.7.7), or sent to your supplier.

Note Schedules cannot be updated in Schedule Maintenance (5.5.3.3) when the Supplier Shipping Schedules module is active.

Manually Updating a Schedule Release

Use Supplier Planning Schedule Maint (5.5.7.6) or Supplier Shipping Schedule Maint (5.5.7.7) to modify planning or shipping schedules. You can change schedule detail data such as requirement dates, quantities, firm or planned status, and fab and raw authorization quantities and dates.

You cannot update a supplier shipping or planning schedule release if the scheduled receipt date is outside of the scheduled order line effective date range. Scheduled orders have both header and line start and end effective dates. When processing the order, the system uses the line start date and the later of the header or line end date as the active order line date range.

See “Effective Dates” on page 97.

Typically, Schedule Update from MRP (5.5.3.1) is used to generate planning and shipping schedules, but these two maintenance programs can also be used to manually create them.

When Auto Update Plan From Ship is Yes in Supplier Schedule Control (5.5.7.24), supplier planning schedules are automatically updated by the system when you make changes to their associated shipping schedules.

See “Auto Update Plan From Ship” on page 122.

When manual changes are made to the shipping schedule or the planning schedule, these changes are used to automatically update the corresponding type 4 supplier schedule so they can be taken into account by MRP the next time it is run. This update takes place regardless of any control program setting.

The following discussion focuses on Supplier Planning Schedule Maintenance. Navigation and data entry in Supplier Shipping Schedule Maintenance is almost the same. Any differences are noted.

- 1 In the first frame, use the Purchase Order, Item Number, Supplier, Ship-To, and Line fields to identify a scheduled order. Enter the release to modify or leave Release ID blank and the current release ID defaults. If you are manually creating a new release for this schedule, enter a new release ID.

Fig. 5.9
Supplier Planning Schedule Maintenance, (5.5.7.6), Cumulative Information

Supplier Planning Schedule Maint: Go To | ACTIONS

Purchase Order: P1121
 Item Number: 1-BB
 Supplier: 5000 Acme Supply Co
 Ship-To: 10000
 Release ID: 1000-01

Line: 2
 UM: EA

Comments:
 Prior Cum Req: 0.0
 Prior Cum Date:

Create Date: 05/02/2007 11:55:27
 Active Start: 05/02/2007
 Active End:

The next frame shows the prior cumulative required and cumulative date. This is the total quantity you have requested from the supplier as of a certain date. The active start and end dates show when this release was active. The current active release has no date in the Active End field.

- 2 The Schedule Detail Data frame displays next. In Supplier Shipping Schedule Maint this frame displays without the Int field.

Fig. 5.10
Planning Schedule Detail Data Frame

Supplier Planning Schedule Maint: Go To | ACTIONS

Purchase Order: P1121
 Item Number: 1-BB
 Supplier: 5000 Acme Supply Co
 Ship-To: 10000
 Release ID: 1000-01

Line: 2
 UM: EA

Planning Schedule Detail Data

Date	Time	Int	Reference	Quantity	Q
05/02/2007	08:00	W	10091	100.0	<input type="checkbox"/>

Interval displays only for planning schedules.

Use this frame to create or modify schedule delivery dates, times, references, and firm or planned quantities. For planning schedules, you can also change the delivery interval type. This is the last frame of Supplier Shipping Schedule Maint.

- 3 For planning schedules, the Resource Authorization Data frame displays next. The dates and quantities in this frame default from information in the scheduled order header (see Figure 5.11).

The fab and raw start and end dates indicate when the supplier is authorized to begin manufacturing or to begin purchasing raw materials to fill this order.

The Fab Qty indicates the quantity of finished items the supplier is authorized to produce for the time period. The Raw Qty indicates the quantity of manufactured items for which the supplier is authorized to purchase raw materials for the time period.

Fig. 5.11
Supplier Scheduled Order Maintenance (5.5.1.13) and Resource Authorization (5.5.7.7) Frames

The image displays two overlapping software frames. The top frame, titled 'Supplier Scheduled Order Maintenance', shows details for Purchase Order P1120 and Supplier 5030. It includes a section for 'Order Line Item Data' with fields for Firm Days, Schedule Days, Schedule Weeks, Schedule Months, Fab Auth Days, Raw Auth Days, Transport Days, Safety Days, and Supplier Item. The bottom frame, titled 'Supplier Planning Schedule Maintenance', shows details for the same purchase order and item number (1-BB). It includes a section for 'Resource Authorization Data' with fields for Fab Qty, Raw Qty, Fab Start, Raw Start, Fab End, and Raw End. A red box highlights the 'Resource Authorization Data' section in the bottom frame, and a red arrow points from this box to the text 'Resource authorization data' located below the frames.

Any changes you make in the Resource Authorization Data frame are applied only to this release of the planning schedule. To make changes that affect other releases, update the order in Supplier Scheduled Order Maintenance.

Transmitting Supplier Schedules

Transmitting a schedule release is the last step of the release process. You can transmit a release in various ways: using EDI eCommerce, sending it as hard copy, or via FAX.

Transmit the schedule release using:

- Supplier Shipping Schedule (35.4.8)
- Schedule Print (5.5.3.8)
- Schedule Print in Fax Format (5.5.3.9)

A schedule that has been transmitted electronically using Supplier Shipping Schedule is considered sent by the system. When you print a schedule release with Schedule Print or Schedule Print in Fax Format, you can optionally designate the printed schedule release as sent.

You cannot edit schedule releases designated as sent. This ensures that the release received by the supplier and the release in your system are identical.

Exporting Supplier Schedules

Use Supplier Shipping Schedule (35.4.8) to export the schedule release to an ASCII text file that can be used for an EDI system transaction.

Only supplier schedule type 5 and type 6 can be exported when the Supplier Shipping Schedules module is active. Only schedule type 4 can be exported when this module is not active.

Schedules are exported only when EDI Schedules is Yes in the header of Supplier Scheduled Order Maintenance (5.5.1.13). Set up supplier-specific EDI information in Trading Partner Parameter Maintenance (35.13.10) by specifying Yes for the appropriate logical parameter:

Send EDI Plan Schedules

Send EDI Ship Schedules

If either schedule export parameter is Yes in the supplier's record, EDI Schedules defaults to Yes in Supplier Scheduled Order Maintenance.

See *QAD EDI eCommerce User Guide*.

Fig. 5.12
Supplier Shipping Schedule (35.4.8)

Fields can be updated only when Supplier Shipping Schedules is active.

Export Supplier Schedule. This value determines whether standard supplier schedules are exported via EDI. When the Supplier Shipping Schedules module is activated, this field is always No and cannot be updated. When the Supplier Shipping Schedules module is disabled, the default is Yes.

Export Planning Schedule. Enter Yes to export supplier planning schedules that match the selection criteria. When the Supplier Shipping Schedules module is deactivated, the default value is No and cannot be updated. When the Supplier Shipping Schedules module is activated, the default is Yes.

Export Shipping Schedule. Enter Yes to export supplier shipping schedules that match the selection criteria. When the Supplier Shipping Schedules module is deactivated, the default value is No and cannot be updated. When the Supplier Shipping Schedules module is activated, the default is No.

Include EDI Only Schedules. Enter No to export both EDI and non-EDI schedules. Supplier Shipping Schedule disregards the setting for EDI Schedules in Supplier Scheduled Order Maintenance and includes both EDI and non-EDI supplier schedules for export.

Enter Yes to export only schedules that have EDI Schedules set to Yes in Supplier Scheduled Order Maintenance.

When this is No and the system cannot find valid associated settings in Trading Partner Parameter Maint (35.13.10), errors result. By setting the field to Yes, you can avoid having to review error messages associated with schedules that should not be exported.

Printing Supplier Schedules

Use Schedule Print (5.5.3.8) to print a schedule release as a material release to the supplier. Use the Schedule Type field to print type 5 or type 6 schedules. When the Supplier Shipping Schedules module is inactive, selection is limited to type 4 schedules only.

Note You specify whether the system uses calendar or working schedules to interpret firm days in the Calendar/Working Firm Days field in Schedule Update from MRP. The system uses the value of this field when printing schedule firm days. If you specify working schedules, the system treats holidays as nonworking days when the supplier schedule is calculated with working firm days.

Fig. 5.13
Schedule Print (5.5.3.8)

You can print and review a schedule release any number of times before you actually transmit it. Indicate when the schedule has been sent to the supplier by responding Yes when prompted to update the Schedule Sent field. To transmit the release, you can mail or deliver it.

Schedule Print creates the printed supplier schedule. The header of this document includes supplier and ship-to information, the release ID, purchase order number, item number, receipt quantity, and cumulative receipts. The ship/delivery pattern displays, then the order detail. The detail shows any prior open quantities, including quantities in transit, and each scheduled requirement.

For each line on the printed schedule:

- Req Qty is the discrete or bucketed quantity for that schedule line.
- Cum Req Qty is the total cumulative requirement, including that line quantity, for the entire life of the order.
- Net Req Qty is the total open quantity including that line quantity.

Fig. 5.14
Supplier Schedule Print Output

```

SUPPLIER SHIPPING SCHEDULE

Supplier: 10032                               Ship-To: 10000
                                              Quality Products Inc.
                                              Manufacturing Division
                                              One World Way
                                              Consolidated Business Plaza
                                              Mount Laurel, NJ
                                              United States of America
Attention:                                     Attention:
Telephone:                                    Telephone:
Fax/Telex:                                    Fax/Telex:

Release ID: suptls2                           Release Date: 02/18/02
Purchase Order: suptl                         Buyer:
Item Number: car-0                            UM: EA   In Transit Qty: 0.0
                                              Receipt Date:          13:15
                                              Receipt Qty: 0.0
                                              Cum Received: 0.0

Supplier Item:                                Packing Slip/Shipper:
Contact:

Interval   Deliver   Deliver
Date      Time      Reference  Q      Req Qty   Cum Req Qty   Net Req Qty
-----
Prior
02/21/02                f      500.0     500.0     500.0
02/22/02                f      60.0     560.0     60.0
02/23/02                f      30.0     590.0     30.0
02/24/02                f      55.0     645.0     55.0
02/25/02                f      30.0     675.0     30.0
    
```

Transmitting the Release by FAX

When you need to transmit a schedule release by FAX, use Schedule Print in Fax Format (5.5.3.9) to produce it. The orders printed by this program are sorted by supplier rather than by site/supplier. At the top of the first schedule for each supplier, a pound sign (#) prints, followed by the supplier's FAX number. The remainder of the information is the same as Schedule Print.

Fig. 5.15
Schedule Print in Fax Format (5.5.3.9)

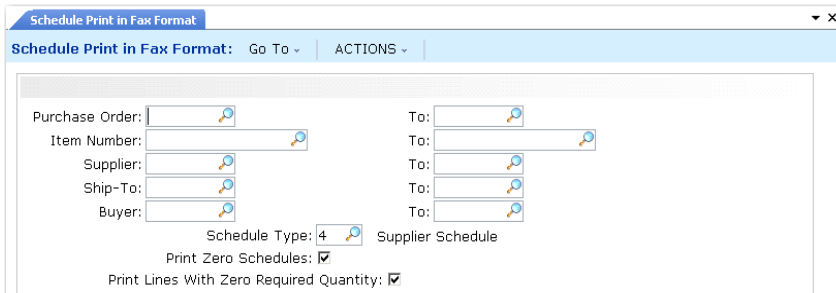

Reviewing and Comparing Releases

Optional modules within the system provide updated review and comparison reports for viewing and analyzing schedule releases. Activating the Supplier Shipping Schedules module lets you use the Schedule Type field in the following programs to select the type of schedule to review.

- Schedule Comparative (5.5.3.15)
- Schedule Inquiry (5.5.3.4)
- Schedule Report (5.5.3.13)

- Schedule History Inquiry (5.5.3.5)

Note When the Supplier Shipping Schedules module is inactive, these programs continue to display module-specific fields, but these fields are not editable.

In addition, the following reports and inquiries are added by this module:

- Ship Delivery Time Inquiry (5.5.7.2)
- Ship Schedule Variance Compare (5.5.7.13)
- Ship to Plan Schedule Compare (5.5.7.14)

Comparing Shipping to Planning Schedules

Use Ship to Plan Schedule Compare (5.5.7.14) to compare active shipping schedules with their corresponding active planning schedules.

Fig. 5.16
Ship to Plan Schedule Compare (5.5.7.14)

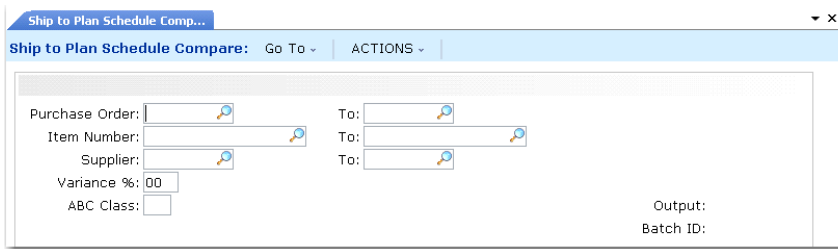

Variance %. Optionally specify a variance percentage (1 to 99 percent) to report only item quantities on schedule detail lines that differ by this percentage or more. When this value is 0 (zero), any quantity variance is reported, regardless of variance percentage.

Variance percentage indicates the extent to which one schedule detail line varies from another, expressed as a percentage value. For example, if you execute a comparison program with all fields left blank, but with Variance % set to 5, the resulting report only includes releases where the schedules differ by five percent or more.

ABC Class. Optionally specify an item ABC class to compare only schedule detail lines containing items that belong to that class. Assign ABC class codes to individual items using Item Master Maintenance (1.4.1). Valid values are A, B, or C.

You can combine this code with a variance percentage for reporting. For example, class A items might be reported at a two-percent variance while class C items are reported at a ten-percent variance.

Fig. 5.17
Ship to Plan Schedule Compare Output (5.5.7.14)

Order	Ln	Item Number	Ship Release Id	Plan Release Id				
PO1014	1	862b	19990118-001	19990118-001				
Date	Ship Discrete Qty	Plan Discrete Qty	Qty Diff	Variance%	Ship Cum Qty	Plan Cum Qty	Cum Qty Diff	Variance%
07/29/02	105.0	100.0	-5.0	05	105.0	100.0	-5.0	05
Order	Ln	Item Number	Ship Release Id	Plan Release Id				
PO1127	1	kwc-a	19990118-005	19990118-005				

Comparing Schedule Releases

Use Schedule Comparative (5.5.3.15) to compare any two releases of the same schedule that reside in the system.

Fig. 5.18
Schedule Comparative (5.5.3.15)

Fig. 5.19
Schedule Comparative Output

		Release ID		Release ID			
		19990111-001		19990113-005			
Date	Time Int Reference	Discrete Qty	Cumulative Qty Q	Discrete Qty	Cumulative Qty Q	Qty Diff	Cum Qty Diff
Prior							
06/11/02	W	0.0	0.0 P		0.0		
06/13/02	08:00 D	0.0	0.0 F				
06/14/02	08:00 D	0.0	0.0 F				
06/18/02				75.0	75.0 F	75.0	75.0
07/18/02	W	75.0	0.0 P			-75.0	75.0
07/25/02				100.0	175.0 F	100.0	175.0
07/25/02	W	100.0	0.0 P			-100.0	175.0
07/01/02				80.0	255.0 P	80.0	255.0
07/01/02	W	80.0	0.0 P			-80.0	255.0
07/08/02				70.0	325.0 P	70.0	325.0
07/08/02	W	70.0	0.0 P			-70.0	325.0
07/15/02				100.0	425.0 P	100.0	425.0
07/15/02	W	100.0	0.0 P			-100.0	425.0
07/22/02				80.0	505.0 P	80.0	505.0

Use Schedule Type to select which schedule type to compare. You must specify two specific release IDs for the schedule releases you are comparing.

Note When the Supplier Shipping Schedules module is inactive, you cannot compare type 5 or type 6 schedules.

Comparing the Current Release with the Prior Release

Use Ship Schedule Variance Compare (5.5.7.13) to compare the current type 6 shipping schedule release with the prior shipping schedule release.

Fig. 5.20
Ship Schedule Variance Compare (5.5.7.13)

Deleting and Archiving Schedules

Use Schedule Delete/Archive (5.5.3.23) to delete and archive unneeded or inactive schedule releases. When you delete or archive schedules while the Supplier Shipping Schedules module is active, your changes affect all three supplier schedule types. When this module is inactive, the delete/archive program affects only supplier schedules (type 4).

Fig. 5.21
Schedule Delete/Archive (5.5.3.23)

The screenshot shows a software window titled "Schedule Delete/Archive". The window has a menu bar with "Go To" and "ACTIONS". The main area contains search criteria on the left and right, and action options in the center. The search criteria include:

- Purchase Order: [Text Field]
- Item Number: [Text Field]
- Supplier: [Text Field]
- Ship-To: [Text Field]
- Buyer: [Text Field]
- Date Created: [Dropdown Menu]
- To: [Text Field]
- To: [Text Field]
- To: [Text Field]
- To: [Text Field]
- To: [Text Field]
- To: [Text Field]

The action options are:

- Inactive Schedule Only:
- Detail Only:
- Delete:
- Archive:
- Archive File: [Text Field]
- Output: [Text Field]

Supplier Milk Run

This chapter describes the supplier milk run features of Enterprise Edition.

***Introduction to Supplier Milk Runs* 142**

Defines the milk run concept and summarizes how the functionality works.

***Milk Run Pickup Sheet Work Flow* 143**

Summarizes the setup and daily use of the functionality.

***Setting Up Supplier Milk Runs* 144**

Describes how to set up control and base data used in pickup sheet processing.

***Creating and Managing Pickup Sheets* 148**

Discusses how to create, maintain, print, and archive pickup sheets.

Introduction to Supplier Milk Runs

QAD Enterprise Edition includes support for the concept of a *milk run* approach to supplier deliveries, including the ability to optimize the efficient use of vehicle capacity.

In a milk run, your own vehicles or vehicles belonging to a logistics provider follow a prescribed route to one or more suppliers. They pick up parts or materials and deliver them to your manufacturing sites. One challenge of milk runs is to avoid sending multiple partially loaded vehicles. With planning, it should be possible to consolidate loads into fewer vehicles—considerably reducing transportation costs. However, this becomes a complex task where supplier schedules are involved, and often involves manual management with spreadsheets.

Customers using supplier schedules can take advantage of Supplier Milk Run features to automatically generate milk run pickup sheets for their transportation providers. This functionality supports two schedule types:

- The traditional type 4 (combined planning/shipping) supplier schedules
- Type 6 supplier shipping schedules offered by the PRO/PLUS Supplier Shipping Schedules module

You can generate pickup sheets in two ways:

- Using an auto-create program that generates pickup sheets for user-specified selection ranges. You can create sheets for multiple supplier networks, sites, and pickup dates. Optionally, you can confirm the sheets while they are being created. When pickup sheets are confirmed, their associated supplier schedule releases are immediately updated and can be transmitted using EDI, print, or fax.
- With a maintenance program that lets you create, modify, and confirm pickup sheets for a single date and supplier transportation network.

Both programs offer the option to run your custom-designed full-truckload optimization program. This program can include your company's rules for calculating the best way to achieve full truckloads—eliminating even more of the manual process.

Regardless of the creation method you use, the same maintenance program lets you make manual changes to the system-generated pickup sheet. For example, if the vehicle is significantly under capacity, you can add quantities from the next day's schedules for one or more suppliers to fill the truck. The system adjusts the schedule for the next day to subtract the additional quantities from the requirements.

Once you have confirmed the sheets either automatically or manually, the system creates new schedule releases to let your suppliers know about any schedule changes made as a result of pickup sheet modifications. It also adds a reference to the pickup sheet ID on the latest release.

Milk Run Pickup Sheet Work Flow

Figure 6.1 shows how pickup sheets fit into the overall supplier schedules work flow.

Fig. 6.1
Using Supplier Schedules with Milk Run Pickup Sheets

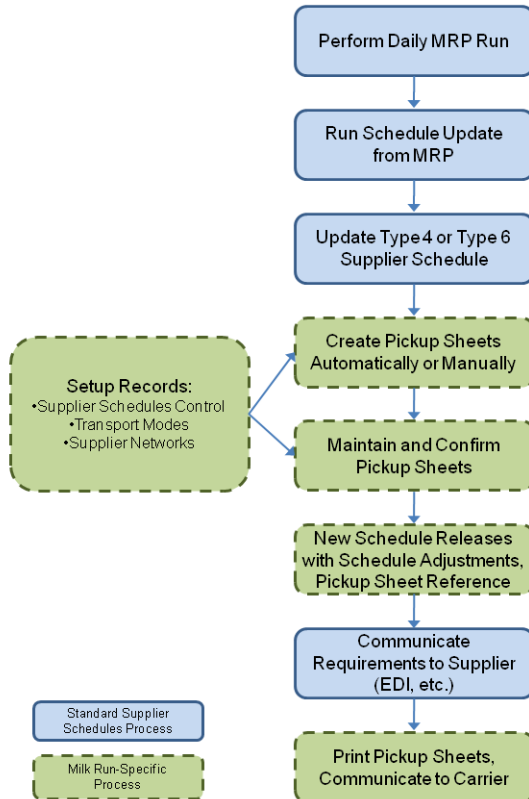

Key steps in using milk runs to support supplier schedule deliveries include:

- 1 Set up base data used by milk run processing:
 - a Specify milk run-specific values in Supplier Schedule Control.
 - b Define vehicles using Supplier Transport Mode Maintenance.
 - c Create cross-references between your suppliers and the transport modes using Supplier Network Maintenance.
- 2 Set up and process supplier schedules as normal, including running Schedule Update from MRP.
- 3 Run Pickup Sheet Auto Create or Pickup Sheet Maintenance to generate pickup sheets that let you communicate the list of suppliers, items, quantities, and pickup sequence to your delivery personnel.
- 4 Use Pickup Sheet Maintenance to optimize the sheets by making manual adjustments; confirm the sheets so they are ready for use.
- 5 The system creates a new schedule release to account for the adjustments and add a reference to the pickup sheet ID.

- 6 Communicate the new release to your suppliers using your standard methods, such as EDI eCommerce.
- 7 Communicate the pickup sheets to your delivery personnel.

Setting Up Supplier Milk Runs

Use the following steps to set up records required to use milk runs:

- 1 In Supplier Schedule Control, add two values used during processing.
- 2 Use Supplier Transport Mode Maintenance to specify information about the vehicles used in milk runs.
- 3 Use Supplier Network Maintenance to create a route that cross-references between your suppliers and the transport modes.

Specify Control Settings

Two fields in Supplier Schedule Control (5.5.1.24) are related to supplier milk runs.

Fig. 6.2
Supplier Schedule Control (5.5.1.24)

The screenshot shows a web browser window titled "Supplier Schedule Control". The browser's address bar and menu bar are visible. The main content area contains the following form fields:

- Generate Date Based Release ID:** A checkbox that is checked.
- Zero Schedules:** A text input field containing the number "1".
- Pickup Sheet Sequence ID:** A text input field containing the text "pickup".
- Pickup Sheet Release ID Prefix:** A text input field containing the text "BB".

Pickup Sheet Sequence ID. Enter the sequence ID (defined in Number Range Maintenance) that is used to generate numbers for pickup sheets that support supplier milk runs.

Pickup Sheet Auto Create and Pickup Sheet Maintenance use this value to assign pickup sheet ID numbers, which can be up to 12 characters long.

Network Release ID Prefix. Optionally, enter up to four characters that the system uses to identify supplier schedule releases based on schedules that were updated during pickup sheet processing.

If you enter a value, the system adds it to the beginning of the next release ID.

If this field is blank, the system increments the original release ID based on standard functionality.

Define Transport Modes

Use Supplier Transport Mode Maint (5.5.1.9) to define vehicles used to transport items from your suppliers to your company.

After defining transport modes, assign them to a transportation network route using Supplier Network Maintenance. The route cross-references suppliers against transport modes.

Fig. 6.3
Supplier Transport Mode Maint (5.5.1.9)

Supplier Transport Mode Maint

Transport ID: 10K-12K

Description: 10000 to 12000

Transport Type: Truck

Max Load Weight: 75,000.0 UM: lb

Max Load Volume: 0.0 UM:

Pallet Capacity: 0

Gross Vehicle Weight: 0.0 UM: lb

Comments:

Transport ID. Specify an ID code for this transportation mode.

Transport ID identifies a vehicle that can be used to carry items between suppliers and your company, such as a truck.

Description. Enter a short description of this mode of transportation.

Transport Type. Enter an optional code used to group different types of transportation modes.

Usually transportation types are associated with item transportation requirements, such as refrigerated units, tanks, vessels, or closed containers.

Max Load Weight. Enter the maximum weight this transport mode can hold, expressed in terms of the unit of measure specified.

The system uses this value when determining the quantity of material that can be included on a pickup sheet.

UM. Enter the unit of measure that the maximum weight is expressed in terms of.

Max Load Volume. Enter the maximum interior cubic volume available in this load space, expressed in terms of the unit of measure specified.

The system uses this value when determining the quantity of material that can be included on a pickup sheet.

UM. Enter the unit of measure that the maximum cube volume is expressed in terms of.

Pallet Capacity. Enter the maximum number of standard sized pallets that can be loaded into this vehicle.

This field is for reference only.

Gross Vehicle Weight. Optionally, enter the total gross weight of the vehicle. This value is for reference.

Note You should express the gross vehicle weight in the same unit of measure as Max Load Volume.

UM. The system displays the unit of measure that the gross vehicle weight is expressed in terms of.

This defaults from the Max Load Volume UM. You cannot update this field.

Comments. Specifies if comments are entered for this function.

If Yes, the next screen prompts you to enter or review comment information. If No, the comment screen does not display.

Describe special requirements, restrictions, or other specifications that apply to this vehicle.

Define Supplier Transportation Networks

Use Supplier Network Maintenance (5.5.1.11) to associate suppliers and vehicles with a defined network, sometimes known as a “milk run route.” You can both define the suppliers that are part of the network and specify the sequence in which the material is picked up. Additionally, you identify which transport modes are valid for the route.

When you run Pickup Sheet Auto Create or Pickup Sheet Maintenance, the system uses these network records to determine the appropriate vehicle to be assigned to the pickup sheet generated for the milk run. Network records are also used to determine which suppliers and supplier scheduled orders are part of the generated pickup sheets.

Use the View Supplier Network browse collection to see information about existing networks.

To define the supplier network:

- 1 In the first frame, specify a network identifier, description, site, and the date the network record takes effect.
- 2 Set the logical fields to control whether you add suppliers, transport modes, or both to the network node, or maintain existing records.
- 3 Based on those settings, use the subsequent frames to add or maintain suppliers.

Fig. 6.4
Supplier Network Maintenance (5.5.1.11)

The screenshot shows a web-based form titled "Supplier Network Maintenance". The form contains the following fields and values:

- Site: 002
- Yo Yo Company
- Network ID: NORTH
- Start: 1/28/2016
- Description: Northern LA County
- Logical:
- Logical:

Site. Enter the site that applies to this supplier network.

Network ID. Enter an alphanumeric code (up to 18 characters) that identifies this supplier network.

Description. Enter a description of this supplier network.

Start. Enter the date on which this supplier network record becomes effective.

Maintain Supplier. Select this option to associate a supplier with this network or to modify an existing supplier association. When this field is No, the Suppliers frame does not display.

Maintain Transport Mode. Select this option to associate a transport mode with this network or to modify an existing transport mode association. When this field is No, the Transport Modes frame does not display.

Fig. 6.5
Supplier Network Maintenance, Supplier Frame

Suppliers			
Supplier	Supplier Name	Order	Pickup Sequence
10S1001	Taylor & Fulton Fruit Co.	Po10	1
10S1001	Taylor & Fulton Fruit Co.		2

Supplier	Supplier Name	Order	Sequence
10S1001	Taylor & Fulton Fruit Co.	Po10	1

Supplier. Enter a supplier ID associated with this supplier network.

Order. Optionally, enter a supplier scheduled order number to associate with this supplier and supplier network. Leave blank to include all orders for this supplier.

Note If you add an order number when a record already exists for this supplier with PO left blank, the system displays a message. In that case, the record with a specific PO is not needed.

Pickup Sequence. Enter the relative sequence in which this supplier/order combination is listed on the generated pickup sheet. If there is more than one supplier on the pickup sheet, pickup sheet create functions use this value to determine the sequence for the vehicle's routing.

Fig. 6.6
Supplier Network Maintenance, Transport Mode Frame

Transportation Modes	
Transport ID	Primary
10K-12K	<input checked="" type="checkbox"/>
JUMBOMAX	<input type="checkbox"/>

Transport ID	Primary
JUMBOMAX	<input type="checkbox"/>

Trans ID. Enter a transportation ID to associate with this supplier network. Transportation IDs are defined in Supplier Transport Mode Maint.

Primary. If there are multiple transportation IDs associated with this supplier network, specify which one should be selected first when the system is creating pickup sheets. Only one transportation ID can have this field selected.

If during pickup sheet creation all the material does not fit in a single vehicle, the system creates multiple pickup sheets using the same vehicle. For example, if the Auto Create function needs to create three pickup sheets for a network, it will create all three pickup sheets using the primary transport mode defined here.

Creating and Managing Pickup Sheets

Depending on your business requirements, you can create pickup sheets in two ways:

- Automatically, using Pickup Sheet Auto Create (5.5.3.19). Typically, this is appropriate when your customer schedule releases are mostly consistent and stable. In many cases, you might be able to use the option to confirm the pickup sheets at the time they are created, so the sheets do not require any manual manipulation at all in Pickup Sheet Maintenance.
- Manually, using Pickup Sheet Maintenance (5.5.3.20). The advantage of this method is that you have complete control over the sheets; you can adjust them as required before completing them by setting the status to Confirmed.

Pickup Sheet Creation Process

Regardless of which method you use, the system uses the same process for creating new pickup sheets. After you enter selection criteria, the system:

- 1 Selects scheduled order lines based on suppliers referenced by selected network ID records and scheduled date, and uses the Transport Days field on the supplier scheduled order line to determine which requirements are “pickup” schedules. See “Transport Days” on page 154.
- 2 Based on supplier network records, matches suppliers with one or more transportation modes, including the sequence in which the suppliers will be listed on the pickup sheet.
- 3 Finds the current release of either the traditional supplier schedule (type 4) or the PRO/PLUS supplier shipping schedule (type 6) and selects open requirements not already included on a pickup sheet.
- 4 Uses vehicle definitions set up in Supplier Transport Mode Maintenance to determine load capacity.
- 5 Creates one or more pickup sheets for each selected day and route, depending on vehicle capacity requirements.
- 6 Optionally, based on your custom rule, optimizes the pickup sheets to achieve full or near-full truckloads.
- 7 When the status is Confirmed (either at the time the pickup sheet is auto-created or manually):
 - Creates a new schedule release to reflect the quantities included in the final requirements on the Confirmed pickup sheet. Based on a setting in Supplier Schedule Control, the new release ID may have a prefix identifier added to it. See “Network Release ID Prefix” on page 144.
 - Adds the Pickup Sheet ID to the Reference field on the schedule release.

Creating Pickup Sheets Automatically

Use Pickup Sheet Auto Create (5.5.3.19) to bulk-generate pickup sheets for supplier milk runs based on selection criteria ranges.

Fig. 6.7
Pickup Sheet Auto Create (5.5.3.19)

Network ID, To. Enter a range of supplier source networks that will have pickup sheets created. Source networks are defined in Supplier Network Maintenance.

Site, To. Enter a range of sites that will have pickup sheets created.

Pickup Date, To. Enter a range of dates on which items to be included on pickup sheets are scheduled to be picked up for delivery to your site.

Status. Specify the status code that the system assigns to auto-created pickup sheets. Valid values are:

Draft (default). The system creates all pickup sheets in Draft status.

Important You must confirm Draft sheets in Pickup Sheet Maintenance before they can be used.

Confirm. The system creates all pickup sheets in Confirmed status. Supplier schedules are updated and new schedule releases are created as part of the auto-create process. You do not have an opportunity to make manual adjustments in Pickup Sheet Maintenance.

See page 154 for more information on pickup sheet status.

Optimization Rule. Optionally, enter a code representing a business rule that your company created for optimizing pickup sheets to ensure full truck loads. Use the lookup/browse to view the list of available custom rules.

When this field is blank, pickup sheet creation functions use default logic, which may not result in completely optimized loads.

Include Subcontract Orders. Specify whether schedules for subcontract orders (Type S) should be included in the selection.

Update. Specify whether schedules selected by the program will have pickup sheets created.

When this is No, the system runs in simulation mode. It generates a report that you can review before running the program in update mode.

When you run the program in update mode, the system creates pickup sheets as described in “Pickup Sheet Creation Process” on page 148.

After the system creates the pickup sheets, confirm them in Pickup Sheet Maintenance (if they are in Draft status) and generate copies for the transport drivers in Pickup Sheet Print.

Manually Creating or Modifying Pickup Sheets

Use Pickup Sheet Maintenance (5.5.3.20) to create or update pickup sheets for supplier milk runs.

Additionally, the program lets you view the capacity and schedule requirements for one or more pickup sheets so that you can optimize milk run vehicle loads by updating quantities or moving requirements to a different pickup sheet.

Important This program is required when you have used the Pickup Sheet Auto Create function with Status set to Draft. Even if you do not need to make manual adjustments to the draft sheets, you must finalize them by changing the status to Confirm.

Fig. 6.8
Pickup Sheet Maintenance (5.5.3.20)

Use the first frame to enter selection criteria.

Site. Enter the site associated with the supplier network to be included on the pickup sheet. This is a required field.

Network ID. Enter the network ID associated with the supplier network to be included on the pickup sheet. This is a required field.

Network IDs are defined in Supplier Network Maintenance.

Pickup Date. Enter the date used for selecting supplier schedule requirements for the pickup sheet. The default is today's date. This is a required field.

Transport ID. When you are selecting pickup sheets to be created or maintained, enter the transport ID of the vehicle to be used on the milk run defined by the pickup sheet. This field can be blank.

- If this field is filled in, the system only creates or displays pickup sheets for the site/network/date/transport combination.
- If this field is left blank, the system creates pickup sheets for the primary transport mode on the network and displays all pickup sheets for the site/network/date combination.

When you are viewing the Pickup Sheet Summary frame, update Transport ID to reassign the pickup sheet to a different vehicle on the same supplier network.

Optimization Rule. Optionally, enter a code representing a business rule that your company created for optimizing pickup sheets. Use the lookup browse to view the list of available custom rules.

When this field is blank, pickup sheet creation functions use default logic, which may not result in completely optimized loads.

When you click Next, the system performs the tasks described in “Pickup Sheet Creation Process” on page 148. The created sheets are displayed in the Pickup Sheet Summary frame. Additionally, the system displays any existing pickup sheets in status Draft for the site/network/date/transport ID combination.

The Pickup Sheet Summary frame includes the pickup sheet number (assigned by Number Range Management) for each sheet, as well the transport ID of the milk run vehicle. Use the Open Weight and Open Volume fields to determine whether there is room in the vehicle for more items.

Fig. 6.9
Pickup Sheet Maintenance, Pickup Sheet Summary Frame

Pickup Sheet ID	Edit	Transport ID	Open Weight	UM	Open Volume	UM
011716000000	<input checked="" type="checkbox"/>	JUMBOMAX	9,500.0	lb	4750.0	cf
011716000000	<input checked="" type="checkbox"/>	JUMBOMAX	9,500.0	lb	4750.0	cf

In the Pickup Sheet Summary frame, click Next to edit the following fields. You can also delete a pickup sheet from this frame; click Delete before clicking Next.

Transport ID. Update this field to reassign the pickup sheet to a different vehicle on the same supplier network.

Edit. Select this option to display editable fields in the next frame that let you move or change quantities, or bring in future requirements to help in load optimization.

When you press Back from the Pickup Sheet Summary frame, the system displays read-only capacity summary information for each pickup sheet that has Edit selected. It also displays the Pickup Sheet Details frame. The system updates the capacity information when you make changes to the details.

Fig. 6.10
Pickup Sheet Maintenance, Pickup Sheet Details

The screenshot shows a software interface for 'Pickup Sheet Maintenance'. At the top, there is a 'Capacity Summary' section with two rows of data:

ID: 011716000000	Open Wt: 9,500.0	lb	Open Vol: 4750.0	cf
ID: 011716000000	Open Wt: 9,500.0	lb	Open Vol: 4750.0	cf

Below this is the 'Pickup Sheet Details' section, which contains a table with the following columns: ID, Date, Item, Quantity, Item, and Schedule.

ID	Date	Item	Quantity	Item	Schedule
011716000000	1/16/2016	san-1	50.0		<input type="checkbox"/>
011716000000	1/16/2016	san-1	50.0		<input type="checkbox"/>

The Pickup Sheet Details frame lets you update the following fields:

ID. Update this field to move this requirement to a different draft pickup sheet that you have chosen for editing.

Important You can only move requirements to sheets that have Edit selected in the Pickup Sheet Summary frame.

If you enter an ID that does not exist, the system creates a new pickup sheet and moves the requirement to it.

Quantity. Update this field to increase or decrease the quantity of the requirement on the pickup sheet. The default is the quantity from the current schedule release.

If the purchase order specifies a standard pack quantity, any quantity change you make should be a multiple of the pack quantity. Otherwise, the system displays a warning. However, you can override the warning to enter any quantity you want.

If you *reduce* the quantity, you can split the requirement by moving the remainder to another pickup sheet.

- If you respond with Yes at the “split” prompt, you can then either select another pickup sheet in the same session, or leave the ID field blank to create a new pickup sheet containing the remaining requirement.
- If you choose not to split, you can decrease the quantity without creating a new requirement for the difference.

If you *increase* the quantity:

- When future requirements are available, the system deducts the amount of the increase from a future requirement when the pickup sheet is confirmed.
- When there are no future requirements, the system displays a warning message. You can override it.

Item Info. Select this option to display a frame that includes the item number, description, weight/UM, volume/UM, transport days, and standard pack quantity.

Fig. 6.11
Pickup Sheet Maintenance, Item Information Frame

ID	Date	Item	Quantity	Item	Schedule
02251600005	2/26/2016	san-1	100.0	<input checked="" type="checkbox"/>	<input type="checkbox"/>
02251600005	2/26/2016	san-8	100.0	<input type="checkbox"/>	<input type="checkbox"/>
02251600005	2/27/2016	san-1	100.0	<input type="checkbox"/>	<input type="checkbox"/>

Item Information					
Item Number:	san-1		Steve's Item		
Ship Weight:	10.00	lb	Volume:	5.00	CF
Transport Days:	1.00		Std Pack Qty:	1	

Schedule. Select this option to view additional future requirements that can be added to this pickup sheet.

The Available Schedule Requirements frame lists additional future schedule requirements for the item. You can use it to move additional future requirements onto a pickup sheet by specifying a value in ID. The lookup browse on ID shows the available pickup sheets that are in Draft status and being edited for the site/network in the current Pickup Sheet Maintenance session.

Note Press Insert while in the Pickup Sheet Details frame to see a comprehensive view of future schedule data for all suppliers in the network. You can pull in any of these future requirements into any of the pickup sheets that are being edited in the Pickup Sheet Maintenance session. You do not have to be in Edit mode on any of the schedule requirements in the details frame to access this view.

Fig. 6.12
Pickup Sheet Maintenance, Available Schedule Requirements Frame

ID	Supplier	Item	Date	Time	Quantity
	3010	san-1	2/25/2016		100.0
	3010	san-8	2/25/2016		100.0
	3010	san-1	2/27/2016		100.0
	3010	san-8	2/27/2016		100.0
	3010	san-8	2/28/2016		100.0

ID. To move a future requirement onto a current pickup sheet, select the pickup sheet ID.

You can also remove requirements from the Pickup Sheet Details frame by pressing Delete. When you delete a requirement from a pickup sheet, the requirement is available to be added to future pickup sheets created in the auto create or maintenance programs.

When you click Next after making changes in the Pickup Sheet Details frame, the system prompts you to update status. If you choose Yes, it displays the Pickup Sheet Status frame. Use this frame to confirm or cancel pickup sheets.

Fig. 6.13
Pickup Sheet Maintenance, Pickup Sheet Status Frame

Pickup Sheet ID	Status	Open Weight	UM	Open Volume	UM
011716000000	Draft	9,500.0	lb	4,750.0	cf
011716000000	Draft	9,500.0	lb	4,750.0	cf

Status. Use this field to either confirm or cancel the pickup sheets in the current session. For information on the effects of pickup sheet status, see page 154.

Once you have completed status updates, use Print Pickup Sheet to output the detailed instructions for the vehicle driver.

Transport Days

The Transport Days value for the scheduled order line represents the number of days needed to move the material from the supplier to the receiving site (not counting the time it takes for the truck to reach the supplier).

This value plays two roles in the pickup sheet creation process:

- It determines whether schedule requirements are eligible for placement on a pickup sheet. A non-zero value indicates a “pickup” schedule—the receiving company sends a vehicle to pick up the material. However, when Transport Days is zero, the requirement is a “delivery” schedule, and the supplier ships the material to the receiving company. The system does not select delivery schedules for milk runs.
- It is used when creating pickup sheets. Most of the time the value in this field is 1 because most milk runs are completed in a day; it takes a day or less for the material to move from the supplier to the receiving site. Using a Transport Days example of 1 day, this means the delivery truck needs to be at the supplier one day ahead of the date of the schedule requirement being picked up, as shown below:

Schedule Requirement	Transport Days	Pickup Date
1/5/2016	1	1/4/2016
1/6/2016	1	1/5/2016

Pickup Sheet Status

Pickup sheets are assigned to one of three statuses:

- **Draft.** This is the default status for new pickup created in Pickup Sheet Maintenance. It also applies to new pickup sheets when you run Pickup Sheet Auto Create with Status set to Draft. You can maintain, confirm, or cancel sheets in when they are in this status. Pickup Sheet Maintenance only allows you to maintain sheets that are in Draft status. You can change them to either Confirmed or Canceled.
- **Confirm.** Pickup Sheet Auto Create applies this status to new pickup sheets only when Status is set to Confirm. You cannot update a Confirmed pickup sheet or change its status. When a pickup sheet is Confirmed, the system:

- Creates a new supplier schedule release for the appropriate scheduled orders. Based on a setting in Supplier Schedule Control, the new release ID may have a prefix identifier added to it. See “Network Release ID Prefix” on page 144.
- Any pickup sheet modifications are pushed to the new schedule release, including:
 - Quantity changes
 - Addition of Pickup Sheet ID to Reference field
- Uses your standard Supplier Schedules work flow to communicate the schedule release to the supplier; for example, with EDI eCommerce.
- **Cancel.** When you change the status to Cancel in Pickup Sheet Maintenance, the system removes all requirements and makes them available to other sheets, and deletes sheet details. However, the header record, including the Pickup Sheet ID, remain in the database. This allows you to track IDs; for example, to account for gaps in sequence numbers. You cannot update a Canceled pickup sheet or change its status.

Viewing Pickup Sheets

You can use the View Pickup Sheet browse collection to see information about existing pickup sheets.

Select a pickup sheet record from the top browse. You can then drill down to two subordinate browses to see pickup sheet details, as well as information about the associated supplier network. Click the Supplier Network Browse tab to access two additional lower-level browses—Supplier Network Sequence Browse and Supplier Network Transport Browse.

Fig. 6.14
View Pickup Sheet

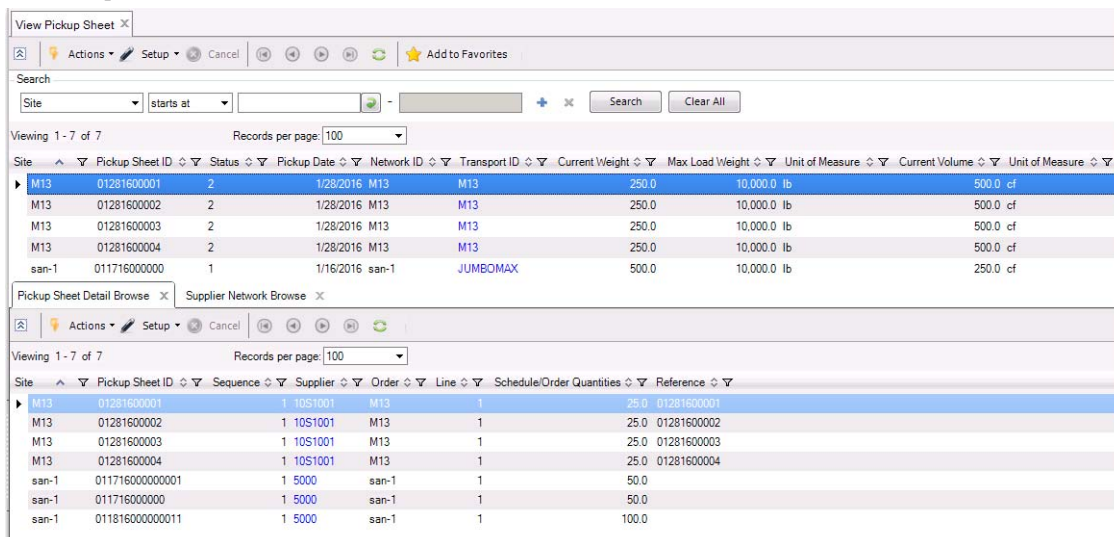

Printing Pickup Sheets

Use Pickup Sheet Print (5.5.3.21) to print or reprint pickup sheets that will go with the vehicle/carrier for the supplier network/milk run route.

Use the filter criteria to select one or more pickup sheets. If you enter a value in Pickup Sheet ID, you cannot enter values in any other fields.

If you enter a value in Network ID, you must also enter a site.

Fig. 6.15
Pickup Sheet Print

The screenshot shows the 'Pickup Sheet Print - Viewer' window. The search conditions are as follows:

Field	Operator	Value	Buttons
Pickup Sheet ID	equals		+ X
Site	equals		+ X
Network ID	equals		+ X
Pickup Date	equals	Current Month	+ X
Transport ID	equals		+ X

The report displays the following details:

Pickup Sheet ID 02251600005
Site san-1 **Steve's Site**
Network ID san-8
Transport ID JUMBOMAX **Jumbo Max Trailer**
Pickup Date 2/25/2016
Status Draft

Pickup Sheet Capacity

Max Load Weight 10,000.00 lb	Max Load Volume 5,000.00 cf
Pickup Sheet Current Weight 3,000.00 lb	Pickup Sheet Current Volume 1,500.00 cf
Open Transport Weight 7,000.00 lb	Open Transport Volume 3,500.00 cf

Schedule Requirements

Order	Line	Item Number	Description	Open Quantity	UM	Supplier	Name
posan1	1	san-1	Steve's Item	100.00	EA	3010	Page Inc.
posan1	2	san-8	Steves #8 Item	100.00	EA	3010	Page Inc.
posan1	2	san-8	Steves #8 Item	100.00	EA	3010	Page Inc.

Pickup Sequence

Seq	Supplier	Name	Address
1	3010	Page Inc.	10 Main Street IL 60616

Deleting and Archiving Pickup Sheets

Use Pickup Sheet Delete/Archive (5.5.3.22) to delete pickup sheet records from the system once online history is no longer needed.

The system does not automatically delete historical information at period or year-end. You can delete this information as frequently or infrequently as you prefer. How often you should run this function depends on how long you need to retain historical information in your database. Most companies keep historical data for at least one year or longer, depending on availability of disk space.

You should run this function twice. First, run it with Delete set to No and review the report. Then, run it with Delete set to Yes.

When you set Delete to Yes, records that satisfy the selection criteria are deleted from the database. If you set Archive to Yes, deleted data are copied to an ASCII file that can be reloaded using Archive File Reload. Otherwise, deleted data cannot be recovered.

When Archive is Yes, the system stores selected data in a file named vdbYYMMDD.hst where vdb is the record type and YYMMDD is the file creation date. If this file does not exist in the system, it is created. If it does exist because you already ran delete/archive the same day, the system adds the additional archived records to the end of the file.

Note Logical fields let you select records based on pickup sheet status of Draft and Confirmed. However, Closed status is not yet implemented. Choosing this option has no affect on record selection.

Fig. 6.16
Pickup Sheet Delete/Archive (5.5.3.22)

The screenshot shows a web-based dialog box titled "Pickup Sheet Delete/Archive". The interface includes a toolbar with "Go To", "Actions", "Copy", "Print", and "Preview" options. The main area contains several input fields and checkboxes:

- Network ID: [Text Field]
- Site: [Text Field]
- Pickup Date: [Dropdown Menu]
- To: [Text Field]
- To: [Text Field]
- To: [Dropdown Menu]
- Include Draft:
- Include Confirm:
- Include Closed:
- Report:
- Delete:
- Archive:
- Archive File: [Text Field]
- Output: [Text Field]

Section 3

Trade Sales

This section discusses how to set up and process trade sales orders using the optional trade sales functionality.

***Creating and Processing Trade Sales Orders* 161**

Describes how to set up, create, and process trade sales orders.

***Generating and Processing Schedules* 175**

Describes how to generate and process different kinds of planning and shipping schedules.

Creating and Processing Trade Sales Orders

This chapter tells you how to set up trade sales and create and process the trade sales order.

Overview of Trade Sales 162

Outlines features of the trade sales module and explains when it should be used.

Setting Up Trade Sales 162

Outlines tasks required to set up trade sales.

Processing the Trade Sales Shipment 169

Illustrates the trade sales order process and explains individual tasks related to it.

Correcting/Returning Trade Sales Orders 173

Describes how to correct and return trade sales orders.

Deleting Trade Sales Orders 173

Describes how to delete trade sales orders and explains how the system deals with deleted orders.

Overview of Trade Sales

To begin a trade sales agreement among a customer, trade sales suppliers, and you as the tier-one supplier, you must first activate the trade sales module; then, you can create the trade sales order. This chapter focuses on trade sales features, activating trade sales, creating and processing the trade sales order, and importing and exporting ASNs.

Creating and processing a trade sales order and importing/exporting ASNs constitute basic trade sales operations. That is, you can have a complete trade sales agreement based only on an existing trade sales order, the import of trade sales supplier ASNs through EDI, and the export of ASNs to the customer through EDI. Additional chapters in this guide describe other aspects of the trade sales process that further expand capabilities and add additional trade sales functionality.

For an overview of trade sales processing, see “Trade Sales” on page 9.

Trade Sales Features

After you activate the optional Trade Sales module in Trade Sales Control (7.3.23), use trade sales to:

- Easily identify a customer scheduled order as a trade sales contract.
- Automatically create a supplier scheduled order for items listed on a customer scheduled order that you identified as a trade sales contract.
- Automatically create a matching trade sales supplier planning schedule when you import or create a trade sales customer planning schedule.
- Automatically create a matching trade sales supplier shipping schedule when you import or create a trade sales customer shipping schedule.
- Automatically create a matching supplier shipping or planning schedule when you reactivate an existing schedule of a customer trade sales order line.
- Automatically set the newly created schedule as the active release.
- Optionally, automatically queue and export newly created supplier planning and shipping schedules to trade sales suppliers.
- View or print system-created trade sales supplier schedules regardless of whether optional modules were activated.
- Automatically generate a PO shipper, PO shipper receipt, SO shipper, and SO shipper confirmation when you import a trade sales supplier ASN.
- Optionally, let the system create the SO shipper from the PO shipper receipt or the supplier’s original ASN.
- Optionally, automatically queue and export an ASN to the customer.

See “Setting Trade Sales Control Value” on page 163.

Setting Up Trade Sales

You must activate Trade Sales, then set up the system with trade sales items and suppliers before you create the order. Additionally, you must set up EDI eCommerce for ASN processing. Figure 7.1 depicts the setup steps.

Fig. 7.1
Trade Sales Setup Workflow

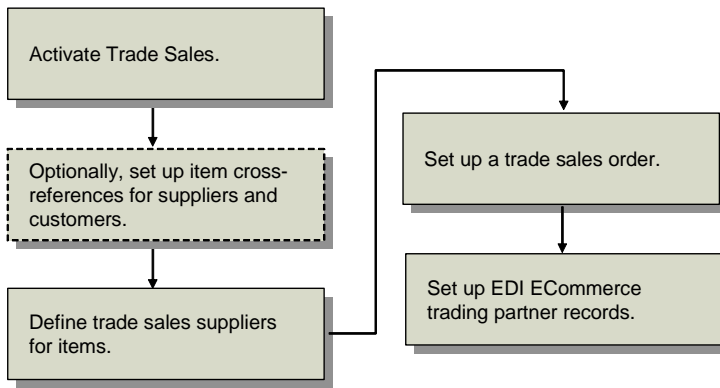

Table 7.1 lists the programs used to complete trade sales setup tasks.

Table 7.1
Trade Sales Setup

Function	Set Up
Item Master Maintenance (1.4.1)	Trade sales items and suppliers of items
Customer Item Maintenance (1.16)	Item cross-reference at customer, if necessary
Supplier Item Maintenance (1.19)	Item cross-reference at trade sales supplier, if necessary
Customer Scheduled Order Maintenance (7.3.13)	Customer trade sales order
Trade Sales Control (7.3.23)	Activate trade sales.
Trading Partner Parameter Maint (35.13.10)	Parameters associated with creating shippers from PO receipt or ASNs and parameters associated with forwarding new ASNs to the customer.

Setting Trade Sales Control Value

Use Trade Sales Control (7.3.23) to activate the trade sales module.

Fig. 7.2
Trade Sales Control (7.3.23)

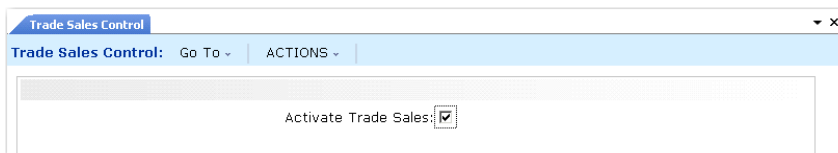

Activate Trade Sales. Indicate whether the optional Trade Sales module is activated.

No (the default): Trade Sales is not activated.

Yes: Trade Sales is activated. You can create a trade sales order in Supplier Scheduled Order Maintenance by setting the Trade Sales field to Yes. When you do, the system views all items on the order as supplied from trade sales suppliers and prohibits you from updating the Trade

Sales field if line items exist. The system automatically creates a supplier scheduled order for a trade sales line item, sets the ship type to blank on the created scheduled orders, and displays an additional Trade Sales PO Data frame.

Setting Up Item Cross-References

In trade sales, the item numbers that the customer and the trade sales supplier use may be different from the item numbers that the system uses to process the order between the customer and trade sales supplier.

To ensure that order and shipment processing among the customer, your company, and the trade sales supplier references the same item:

- Use Item Master Maintenance (1.4.1) first to define items that you reference on trade sales orders.
- If necessary, use Customer Item Maintenance (1.16) to cross-reference the customer item number to your item number.
- If necessary, use Supplier Item Maintenance (1.19) to cross-reference the trade sales supplier item number to your internal item number.

See *QAD Master Data User Guide*.

Defining Trade Sales Suppliers for Items

Trade sales suppliers must be defined for the items you are processing on your trade sales order. Specify trade sales suppliers for items in Item Master Maintenance (1.4.1). You associate one trade sales supplier with a particular trade sales item. Enter the trade sales supplier in the Supplier field in the Item Planning Data frame in Item Master Maintenance.

Fig. 7.3
Item Master Maintenance (1.4.1), Item Planning Data Frame

The screenshot shows the 'Item Master Maintenance' window for item '100A'. The 'Item Planning Data' section is expanded, showing various fields for planning and procurement. A red box highlights the 'Supplier' field, which is currently empty. A callout line points from this field to the text 'Specify trade sales supplier of item.' Other visible fields include 'Buyer/Planner', 'PO Site: MD200', 'Purchase/Manufacture: M', 'Configuration Type', 'Inspection', 'Lead Times (Ins, Mfg, Pur, Cum)', 'Order Multiple: 1', 'Yield Percent: 100.00%', 'Run Time: 0.000', 'Setup Time: 0.000', 'EMT Type: NON-EMT', 'Network Code', 'Routing Code: MDR100', and 'BOM/Formula'.

Specify trade sales supplier of item.

Setting Up a Trade Sales Order

Use Customer Scheduled Order Maintenance (7.3.13) to create a trade sales customer scheduled order. The Trade Sales field in Customer Scheduled Order Maintenance identifies a trade sales contract and initiates trade sales processing.

When you identify an order as a trade sales order, the system:

- Prohibits updating the Trade Sales field once line items exist
- Manages all of the items on the order as supplied from trade sales suppliers
- Sets Type to blank on the trade sales order
- Automatically creates the supplier scheduled orders for each supplier of the items on the trade sales order
- Displays an additional Trade Sales PO Data frame at the line item level.

Once you set an order as a trade sales order, the system prevents you from:

- Modifying the system-created supplier scheduled order that is linked to the trade sales order
- Allocating percentages for a supplier scheduled order that is linked to a trade sales order in Scheduled Order MRP % Maint (5.5.1.17)

Because you cannot assign percentages to trade sales schedule orders, the system does not create schedules for trade sales supplier scheduled orders and planned order demand is not satisfied through Schedule Update from MRP (5.5.3.1).

To create a trade sales order:

- 1 In the header Ship-To field, enter the customer.
- 2 In the header Ship-from field, enter the site responsible for managing the trade sales process for the items listed on the order.

Note If you are running system software in a multi-database mode, trade sales orders, schedules, receipts, and shipments must reside in the same database; therefore, the ship-from site on a trade sales order cannot be a remote site.
- 3 Set Trade Sales to Yes in the Order Data frame. See Figure 7.4.

The Trade Sales field cannot be updated if you have existing line items that have schedules for them or receipts against them, or the order is in a remote database.

Note Sequenced schedules are not supported when using a trade sales arrangement; therefore, if the Trade Sales field is Yes, the Sequenced field cannot be updated and vice versa.
- 4 Choose one of the following:
 - a If line items exist, confirm the automatic creation of supplier scheduled orders when the system prompts you.
 - b If this is a new order, enter line items. The system creates the supplier scheduled orders for the line items after you enter the line.
- 5 View trade sales data in the Trade Sales PO Data frame at the line-item level. See Figure 7.5 on page 167.

Fig. 7.4
Customer Scheduled Order Maintenance (7.3.13), Order Data Frame

Specify a trade sales order.

Trade Sales. This field enables or disables trade sales functionality.

No (the default): This is a standard scheduled order.

Yes: The system:

- Automatically creates a supplier scheduled order—a type of purchase order—for each supplier of the line items
- Sets the ship type to blank on the trade sales order. See Figure 7.5 on page 167.
- Displays an additional Trade Sales PO Data frame at the line item level
- Prohibits you from setting the Sequenced field

If line items already exist on the order, the system prompts you to confirm that you want trade sales purchase orders created for them. Once you confirm, the system creates the trade sales supplier scheduled orders for the suppliers associated with the items in Item Master Maintenance. If a valid supplier is not associated with the item on the order, an error displays and you cannot continue. If any existing lines have existing schedules or if you received items for a line, an error displays and you cannot continue.

If line items do not exist, the system creates a new supplier scheduled order line as you enter new line items.

If the trade sales order has more than one item supplied by the same supplier, the system creates one supplier scheduled order with multiple lines for the items; however, if the trade sales order has multiple order lines with the same item number and the same supplier, the system creates multiple supplier scheduled orders for one supplier.

Fig. 7.5 Customer Scheduled Order Maintenance (7.3.13), Order Line Item Data Frame

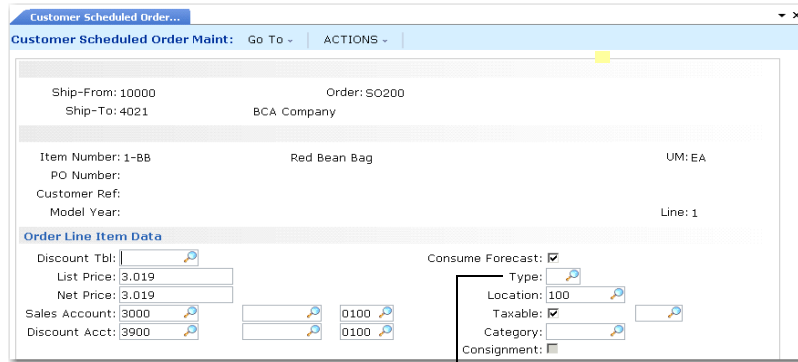

Trade sales sets the ship type.

Type. The system automatically sets the Type to blank when you set Trade Sales to Yes in the Order Line Data frame. You cannot modify Type once you set the order as a trade sales order. When the order is not a trade sales order, you can modify the ship type up to the time that you ship or invoice a quantity.

When Trade Sales is set to Yes in the header, the Trade Sales PO Data frame displays at the line item level. This frame is display only.

Supplier. This field displays the trade sales supplier ID for the item.

PO Number. This field displays the supplier scheduled order number that the system created for the trade sales line item.

Note Use Scheduled Order Inquiry (5.5.1.14) or Purchase Orders by Order Report (5.9.1) to view details of a supplier scheduled order. If you attempt to access trade scheduled orders in either Supplier Scheduled Order Maintenance (5.5.1.13) or Purchase Order Maintenance (5.7), the system displays an error message.

PO Line. This field displays the supplier scheduled order line number for the item.

Modifying the Trade Sales Order

If you modify any of the following fields in the trade sales order, the system automatically updates them on the supplier scheduled order it created:

- Fab Auth Days
- Raw Auth Days
- Cum Start
- Max Order Qty
- Location
- Comments

Consigned Supplier Scheduled Orders

If you use Supplier Consignment Inventory, you can set a trade sales order as a consigned order; however, the setting of the Consignment fields on the trade sales supplier scheduled order are not related to the Consignment setting of the trade sales order. The system sets the Consignment field for the trade sales order based on defaults.

Supplier scheduled orders have a Consign field at both the header and line levels. The header field defaults first from the Consignment Orders field in Supplier/Item Controls Maint (5.18.1) for a specific supplier. If no setting exists for a specific supplier, it defaults from Consignment Orders in Supplier Consignment Control (5.18.24).

The supplier scheduled order line-level Consignment field defaults:

- First from the Consignment Orders field in Supplier/Item Controls Maint (5.18.1) for that line's supplier-item combination
- If no default is defined in Supplier/Item Controls Maint, from the header Consignment field

When Consignment is set to Yes, the system bases the consignment related field, Maximum Aging Days, on the consignment control record it uses.

Setting Up EDI eCommerce

Before you can begin processing trade sales transactions with eCommerce, you must have the following data set up:

- EC subsystem definition
- Exchange file definition
- EC subsystem/exchange file cross-reference
- Application document definition
- Implementation definition
- Transformation definition

See [QAD EDI eCommerce User Guide](#).

The following sections describe additional EDI eCommerce settings for trade sales processing.

Determining Your ASN Process

There are two ASN processes that you can set up EDI eCommerce to manage:

- Trade sales suppliers send you an original ASN.
- Trade sales suppliers send you a copy of the ASN.

If the trade sales supplier sends you the original ASN, you send your own ASN to the customer. The system automatically creates your ASN from the SO shipper. If the trade sales supplier sends you a copy, you typically do not send your own ASN to the customer as this duplicates data the customer receives and can lead to confusion.

The system creates an SO Shipper automatically from the ASN data that the trade sales supplier sends to you, so there is no additional ASN setup required to create the SO shipper.

Setting Up Trading Partner Parameters

You set fields in Trading Partner Parameter Maint (35.13.10) that let EDI eCommerce process trade sales ASNs.

You must set fields for both the customer trading partner parameter record and the supplier trading partner parameter record. The following sections describe the fields.

Fig. 7.6
Trading Partner Parameter Maint (35.13.10)

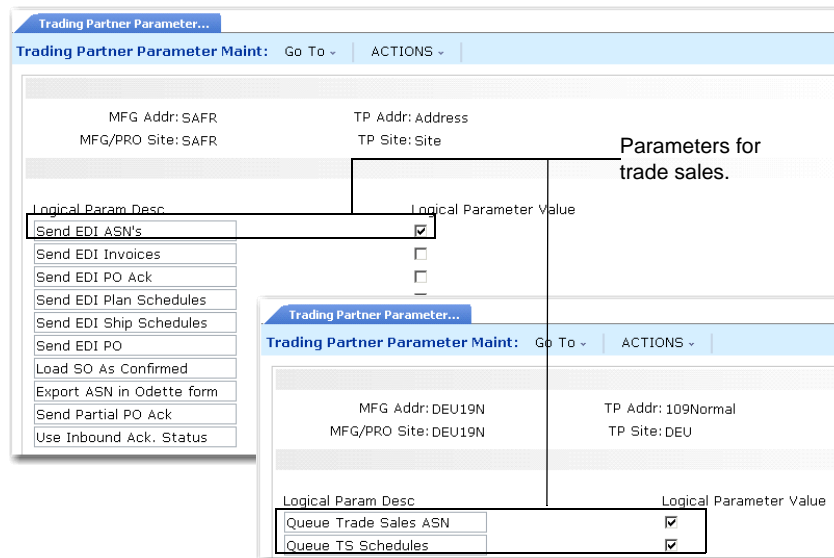

Send EDI ASNs. This parameter lets you send ASNs to the customer using EDI, regardless of the EDI eCommerce export method you use. Set this field for the customer trading partner parameter records.

No (the default): Do not send ASNs to the customer.

Yes: Send ASNs to the customer.

Queue Trade Sales ASN. This parameter determines if the system should queue an ASN for export to the customer based on the confirmed SO shipper data. Set this field for the supplier trading partner parameter records. You export queued ASNs using eCommerce Manager.

No: The system does not queue an ASN for export to the customer.

Yes: The system queues the shipper as an ASN for export to the customer after it confirms the SO shipper.

The system creates SO shippers when you import a supplier's ASN. To review all SO shippers for a supplier before exporting them, set this field to No. Once you review the data, you can export the shippers using Shipment ASN Export (35.4.1).

Processing the Trade Sales Shipment

If you plan to send and receive ASNs, you can start processing trade sales orders only after you have set up all EDI eCommerce functionality and created the trade sales orders. This section describes the process flow depicted in Figure 7.7.

Fig. 7.7
Trade Sales Order Process

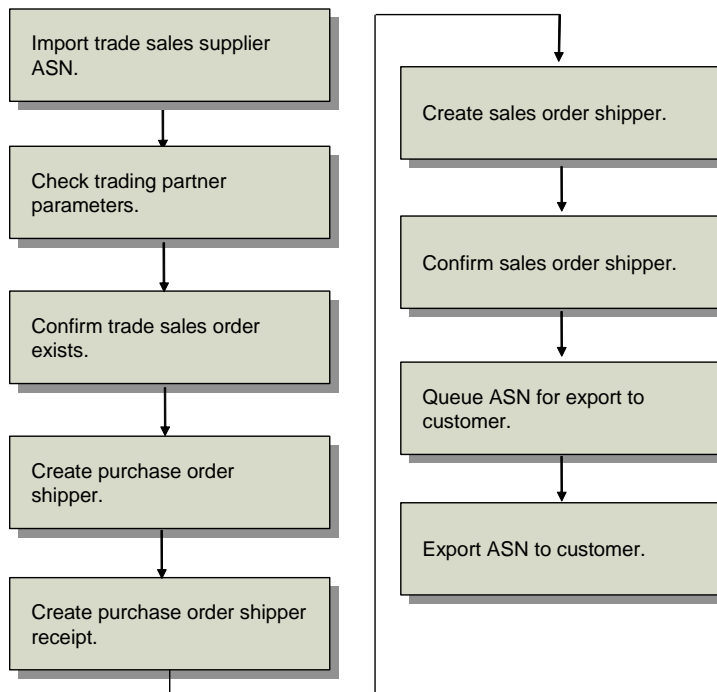

Since most of the trade sales process is automated, once you complete the setup tasks, you perform only the following tasks:

- Import the trade sales supplier ASN.
- Optionally, verify that the system-created trade sales shipment-related documents.

In Figure 7.7, the system performs all steps except the first and last step.

See “Setting Up Trade Sales” on page 162.

Importing the ASN

You import the ASN from the trade sales suppliers to initiate the automatic generation and processing of trade sales shipment documents. Use Document Import (35.1) or eCommerce Manager (35.5) to import all incoming EDI documents.

Once you import the ASN, the system:

- Creates a PO shipper, then receives items against it
- Creates an SO shipper, then confirms it
- Optionally, creates an ASN and sends it to the customer

See *QAD EDI eCommerce User Guide*.

Sending/Receiving RAN Data

If the Trade Sales supplier sends an ASN with release authorization number (RAN) data that they shipped to the customer, the system compares RAN data on the incoming ASN with the RAN data on the customer schedule. This lets the system know how much the supplier shipped for each RAN.

PO Shipper

The system creates the PO shipper for the trade sales supplier scheduled order based on the supplier name and item number on the trade sales supplier ASN. The PO shipper contains the item numbers, quantities, and lot/serial numbers listed in the imported ASN.

PO Shipper Receipt

The PO shipper receipt records the temporary addition of inventory in the system for the items recorded on the PO shipper.

SO Shipper

The system creates the SO shipper from the PO shipper receipt or directly from the data on the inbound ASN, depending on trading partner parameters. The system creates the SO shipper for the customer scheduled order that is linked to the supplier scheduled order. The supplier scheduled order is the one for which the system created a PO shipper.

The SO shipper ID is assigned based on the sequence specified in Container/Shipper Control (7.9.24).

See “Setting Up Trading Partner Parameters” on page 169.

SO Shipper Confirmation

The SO shipper confirmation records shipment of the material listed on the SO shipper and issues those materials out of inventory.

SO Shipper Queue for Export

The system queues the confirmed SO shipper for export to the customer based on trading partner setup for the supplier.

Verifying Trade Sales Documents

Use reports and inquiries in the Supplier Schedules Setup Menu (5.5.1), Supplier Schedules Processing Menu (5.5.3), and Customer Schedules Setup Menu (7.3) to verify scheduled order data.

You can only access or maintain a trade sales order in Customer Scheduled Order Maintenance (7.3.13). If you attempt to access or maintain a trade sales order in Sales Order Maintenance (7.1.1), the system displays an error message and prompts you to enter another sales order number.

Exporting ASNs to the Customer

You run eCommerce Manager (35.5 and 35.22.13) to automatically export ASNs to the customer. The ASNs must be queued for export first. If you want to review the ASNs first, do not run eCommerce Manager.

Figure 7.8 shows you the option to select for trade sales ASN processing. As soon as you select the option to export ASNs and respond to prompts, eCommerce Manager runs.

Fig. 7.8
eCommerce Manager (35.5)

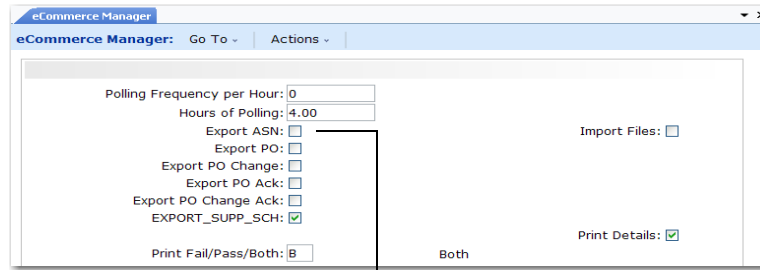

Set for trade sales.

Export ASN. Indicate Yes or No to export ASNs that the system queues for export to the customer. The system queues ASNs for export when it processes trade sales or Enterprise Material Transfer (EMT) orders.

No (the default): Do not export ASNs during this session.

Yes: Export ASNs during this session. The system sends ASNs in the queue to both trade sales customers and EMT business units.

See “Determining Your ASN Process” on page 168.

Automating the Trade Sales ASN Process

To completely automate the trade sales process, after you set up parameters in Trading Partner Parameter Maint, use the following procedure:

- 1 In eCommerce Manager (35.5), set these fields:
 - Export ASN to Yes
 - Import Files to Yes
 - All other fields to No
- 2 Specify the number of hours you want EDI eCommerce to run.
- 3 Specify the intervals at which EDI eCommerce checks the queues for documents that require exporting or importing.

Example Set fields as listed in step 1. Set Polling Frequency Per Hour to 1 and Hours of Polling to 24. For the next 24 hours, EDI eCommerce imports ASNs received from the trade sales suppliers. The system creates the shipping documents automatically once EDI eCommerce imports the ASN. EDI eCommerce checks the queue for ASNs to export and sends any in the queue to the customer. No intervention is required by you during the 24 hours.

You can also automatically export and import trade sales schedules using this method by setting Export Supplier Schedule to Yes in eCommerce Manager. If you do this, the entire trade sales process is automated once you create the order.

See *QAD EDI eCommerce User Guide*.

Correcting/Returning Trade Sales Orders

You correct and return trade sales orders manually. The system does not include automatic return processing to trade sales suppliers.

Deleting Trade Sales Orders

To delete a trade sales customer scheduled order line, delete the line in Customer Scheduled Order Maintenance (7.3.13) or delete the entire order using Customer Scheduled Order Maintenance. You cannot delete a system-created supplier scheduled order using programs that delete or archive orders.

When you delete the order line, the system:

- Informs you that schedule releases exist for the supplier scheduled order line that is linked to this customer scheduled order line, then prompts you to continue with the deletion
- Deletes all supplier schedules for the linked supplier scheduled order line
- Deletes the linked trade sales supplier scheduled order line created for the customer scheduled order line
- Deletes the customer scheduled order line as well as the customer scheduled order if it was the last or only line.

The system deletes these items, even if a quantity has been received against the supplier scheduled order line.

Generating and Processing Schedules

This chapter tells you how to generate and process trade sales customer planning and shipping schedules and supplier planning and shipping schedules.

Overview of Trade Sales Schedule Processing 176

Explains when and how trade sales schedules are created.

Setting Up for Schedule Processing 176

Explains how to set up parameters in Trading Partner Parameter Maint to export schedules automatically.

Processing the Schedules 178

Describes the process flow and how to manually or automatically process schedules.

Deleting Trade Sales Schedule Releases 183

Describes how to use Customer Plan Schedule Maint or Customer Ship Schedule Maint to delete schedules.

Overview of Trade Sales Schedule Processing

In a trade sales agreement, after the trade sales order exists in the system, you can expand the trade sales process to include trade sales schedule releases. The system automatically creates matching supplier planning and shipping schedules for the trade sales supplier when you:

- Import a trade sales customer planning or shipping schedule.
- Create a new trade sales customer planning or shipping schedule.
- Reactivate an existing inactive trade sales customer schedule.

The system creates the trade sales supplier schedules without running Schedule Update from MRP (5.5.3.1). You can optionally export the system-created supplier schedules automatically to the trade sales suppliers.

You use EDI eCommerce programs to import customer schedules and to export system-created supplier planning or shipping schedules. You can set up EDI eCommerce to export the system-created supplier schedules automatically or you can view them before you export them. You can view system-created trade sales supplier schedules regardless of whether you enable the optional supplier shipping schedule module.

See *QAD EDI eCommerce User Guide*.

Setting Up for Schedule Processing

Since trade sales agreements focus on the automation of supplier schedule creation and export after you import a customer schedule, little setup is required for trade sales schedule processing. Figure 8.1 depicts the setup steps.

Note The system automatically creates supplier schedules if you create or modify a customer schedule release, too. Directions to create or update manually in the system are described in this chapter. See “Generating Customer Schedules” on page 178.

You use Trading Partner Parameter Maint (35.13.10) to set trading partner parameters to export trade sales schedules to trade sales suppliers automatically.

Fig. 8.1
Trade Sales Setup Workflow

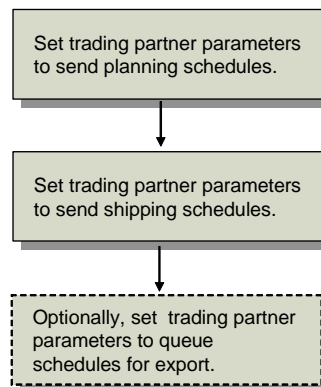

You must set the trading partner parameters for supplier records. Figure 8.2 depicts the trading partner parameter options you set.

Fig. 8.2
Trading Partner Parameter Maint (35.13.10)

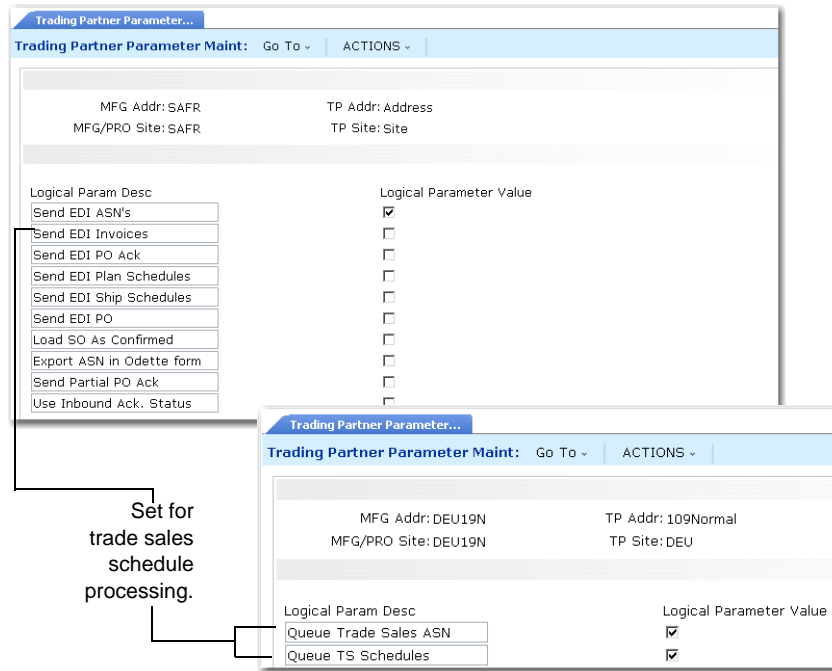

Send EDI Plan Schedules. Indicate if the system sends planning schedules using EDI eCommerce to the trading partner you specify in the header.

No (the default): You cannot send planning schedules using EDI eCommerce.

Yes: You can send planning schedules using EDI eCommerce.

Send EDI Ship Schedules. Indicate if the system sends shipping schedules using EDI eCommerce to the trading partner you specify in the header.

No (the default): You cannot send shipping schedules using EDI eCommerce.

Yes: You can send shipping schedules using EDI eCommerce.

Queue TS Schedules. This parameter determines whether system-created supplier schedules are queued for export.

No (the default): The system does not queue newly created trade sales supplier planning or shipping schedules for export.

Note If No and you have no schedules already queued for export, you can export any supplier planning or shipping schedules using Supplier Shipping Schedule (35.4.8).

Yes: The system automatically queues for export any supplier planning or shipping schedules it creates for this supplier's scheduled order. The system queues the supplier schedules for export as soon as it creates them.

When you queue a schedule for export, the entry in the queue includes the schedule type and the scheduled order and line. EDI eCommerce retrieves and exports only the supplier schedule that is active at the time of export. After successful export, the system deletes the queued entry.

If the system creates a new supplier planning or shipping schedule for this supplier, the new schedule is automatically the active supplier planning or active supplier shipping schedule for this order line. EDI eCommerce exports the new active supplier shipping schedule.

Processing the Schedules

You can start processing trade sales schedules only after you have set up all EDI eCommerce functionality and a trade sales order exists. This section describes the process flow for trade sales schedules.

Trade sales schedule functionality primarily involves the automatic creation of trade sales supplier shipping and planning schedules when you import, create, or update a customer planning or shipping schedule.

See *QAD EDI eCommerce User Guide*.

You can choose to automate the entire supplier schedule process. In this case, once you import a customer planning or shipping schedule, you perform only the following tasks:

- Verify that the system created matching supplier planning or shipping schedules for the customer schedules.
- Verify that the system exported the system-created schedules to your trade sales suppliers.

See “Automating the Trade Sales Process” on page 183.

Figure 8.3 depicts the process.

Fig. 8.3
Trade Sales Schedule Process

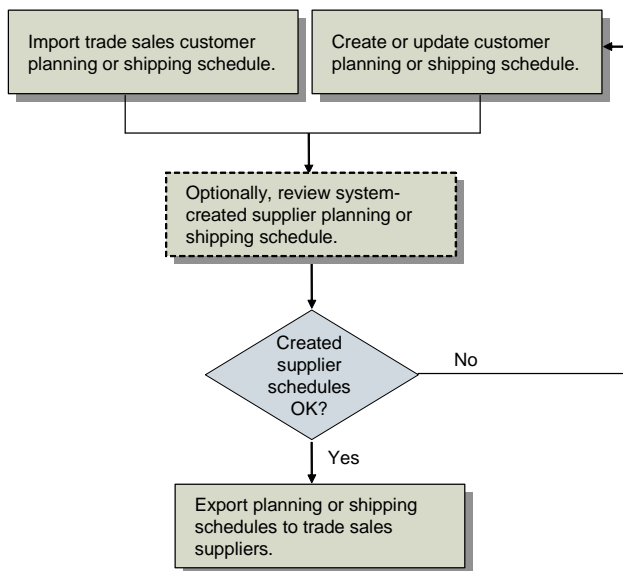

Generating Customer Schedules

The system automatically creates trade sales supplier schedules when you:

- Import trade sales customer schedules.

- Create a new trade sales customer schedule and make it active.
- Reactivate a nonactive trade sales customer schedule.

Importing Customer Schedules

Use Document Import (35.1) to import customer planning or shipping schedules.

See *QAD EDI eCommerce User Guide*.

Note You can also use eCommerce Manager (35.5 and 35.22.13) to import any documents that are ready to import.

When you import a customer planning schedule, the system automatically generates a new trade sales supplier planning schedule. When you import a customer shipping schedule, the system automatically creates a new trade sales supplier shipping schedule.

The system automatically sets a newly created trade sales supplier schedule as the active release.

Capturing Data that Did Not Import

In trade sales agreements, not all information that you receive in a customer schedule EDI document may be necessary for import. You can pass information from an EDI-received customer schedule directly to the trade sales supplier without importing it by using the EDI eCommerce turnaround data feature.

Use the frame that sets up capture of turnaround data in EDI eCommerce Implementation Definition Maintenance (35.15.13). Specify inbound and outbound schedule data as type T. The gateway for the inbound document places the data in the turnaround repository while the gateway for the outbound document retrieves the data from the turnaround repository.

Creating Customer Schedules

You create a customer planning schedule in Customer Plan Schedule Maint (7.5.1). You create a customer shipping schedule in Customer Ship Schedule Maint (7.5.2).

You can create a new customer planning or shipping schedule for a trade sales order and make that schedule the active trade sales release. When you do this, the system automatically creates matching supplier planning or shipping schedules.

Note You make a schedule active by specifying Yes to `Make Current Schedule Active?` in the last frame of the customer schedule maintenance programs.

Modifying a Nonactive Trade Sales Customer Schedule

You modify trade sales customer schedules in Customer Plan Schedule Maint (7.5.1) or Customer Ship Schedule Maint (7.5.2).

When you change any field on the currently active customer planning or shipping schedule that already has a matching trade sales supplier schedule, the system creates a newer supplier schedule with a higher release ID.

The system sets the new supplier schedule as the active release and ends the previous release.

If the system supersedes a queued schedule before EDI Ecommerce exports it, it is not exported. EDI eCommerce exports only the currently active schedule.

System-Created Supplier Schedules

When the system automatically creates trade sales supplier planning or shipping schedules, it copies newly created or updated customer schedule information to the new supplier schedule and assigns a new release ID to the schedule.

The system creates the supplier planning or shipping schedules regardless of the Enable Shipping Schedule setting in Supplier Schedule Control (5.5.7.24). Typically, when Enable Shipping Schedule is No, you cannot generate planning or shipping schedules, just standard supplier schedules.

The system copies the following data from the customer planning or shipping schedule to the matching supplier planning or shipping schedule:

- Item number and quantity
- Fabrication and raw authorization quantities and dates
- Prior cumulative date and Prior Cum Required field setting
- Shipping detail data

You cannot edit the system-created trade sales supplier planning or shipping schedules; however, you can view them.

See “Viewing Trade Sales Schedules” on page 181.

Trade Sales and MRP

The system automatically copies trade sales customer schedules into corresponding trade sales supplier schedules. Since suppliers ship the material directly to the customer, there is no requirement for you to:

- Create a required ship schedule (RSS).
- Run MRP to generate planned orders to meet the demand from the customer.
- Run Scheduled Update from MRP (5.5.3.1) to generate supplier schedules for planned orders.

It is possible to create an RSS and run MRP so that you can run reports for planning purposes; however, in trade sales processing, Schedule Update from MRP does not generate supplier schedules for a trade sales order. If you wish to run MRP, you must:

- Create an RSS for the trade sales customer scheduled order.
- Set up the items to be planned by MRP.

MRP matches the firm trade sales customer demand schedule details with the matching supplier schedule details. MRP also generates planned orders for the remaining planned trade sales customer demand. Since you cannot specify a percentage value for a trade sales supplier scheduled order using Scheduled Order MRP % Maint (5.5.1.17), you cannot use Schedule Update from MRP to generate supplier schedules for a trade sales supplier scheduled order. So, with each execution, MRP continues to replan the non-firm RSS schedule quantities.

You can prevent MRP from planning a trade sales item by either setting Plan Orders to No or leaving Order Policy blank in Item Master Maintenance (1.4.1).

If you order the same item from the same supplier for both trade sales and non-trade sales purposes and want to execute MRP for both, you should create two different item numbers. Set up both items with Plan Orders set to Yes and Order Policy set appropriately.

If you use the same item number for your trade sales and non-trade sales items, MRP combines the demand, offsets the demand by the firm schedule details, then generates planned orders. Schedule Update from MRP then generates supplier schedules for the remaining quantity using the non-trade-sales supplier scheduled order.

Raw and Fabrication Authorization Data

Customers and suppliers sometimes use raw and fabrication authorization data to determine the quantity the supplier is authorized to procure for a particular day/time on a schedule.

If the trade sales customer sends schedules that include raw and fabrication authorization data, the system captures and copies raw and fabrication authorization quantities and dates onto the matching supplier schedules.

Requirement Details

The system does not capture and copy requirements detail on customer schedules. Requirement details can include release authorization numbers (RANs) and other data that the customer includes in their schedules. To send the customer RANs or other details to trade sales suppliers, you must capture and forward the details separately.

See “Capturing Data that Did Not Import” on page 179.

Viewing Trade Sales Schedules

Table 8.1 lists reports and inquiries you can use to view or track trade sales supplier planning or shipping schedules. You can use the reporting programs to review a supplier’s planning or shipping schedule before exporting it.

Table 8.1
Trade Sales Supplier Schedule Reports/Inquiries

Report/Inquiry	Menu Number
Schedule Inquiry	5.5.3.4
Schedule History Inquiry	5.5.3.5
Schedule Report	5.5.3.13
Schedule Comparative	5.5.3.15
Schedule Authorization Report	5.5.3.17

Note To change a trade sales supplier planning or shipping schedule, modify the trade sales active customer planning or shipping schedule. See page 179.

Exporting Supplier Schedules

You run eCommerce Manager (35.5 and 35.22.13) to automatically export queued system-created supplier schedules to trade sales suppliers. Figure 8.4 shows you the option to specify for trade sales schedule processing.

Fig. 8.4

eCommerce Manager (35.5 and 35.22.13)

The screenshot shows the eCommerce Manager configuration window. The following options are visible:

- Polling Frequency per Hour: 0
- Hours of Polling: 4.00
- Export ASN:
- Export PO:
- Export PO Change:
- Export PO Ack:
- Export PO Change Ack:
- EXPORT_SUPP_SCH: (highlighted by a callout)
- Print Fail/Pass/Both: B
- Both
- Import Files:
- Print Details:

Set to automatically export supplier schedules.

Export Supplier Schedules. Indicate Yes or No to export supplier planning or shipping schedules automatically.

No (the default): Do not export supplier shipping or planning schedules.

Note You can manually export trade sales supplier schedules using Supplier Shipping Schedule (35.4.8).

Yes: Export queued supplier shipping or planning schedules.

Note You queue trade sales supplier planning or shipping schedules for export by setting Queue TS Schedules to Yes in Trading Partner Parameter Maint. See [QAD EDI eCommerce User Guide](#).

Export Message Type

When you queue a trade sales supplier schedule for export, the system generates a record in the trq_mstr database table to indicate that the supplier schedule is queued for export. When you run eCommerce Manager (35.5 and 35.22.13), the system scans the trq_mstr table for records.

When you set an export field to Yes in eCommerce Manager, the system looks for a specific message type among existing trq_mstr records. Several message types can be present in the trq_mstr table at the same time. Table 8.2 lists the kinds of message types stored in trq_mstr records. The system searches for sequences in a logical order designed to minimize potential conflicts in processing. The Seq column indicates the order in which data is exported. Trade sales supplier schedules are number 7 in the sequence.

Table 8.2

Use of Export Transmission Records

Seq	Type	Message
1	ORDRSP-I	PO Acknowledgment
2	ORDRSP-C	PO Change Acknowledgment (customer initiated)
3	ORDRSP-S	PO Change Acknowledgment (supplier initiated)

Seq	Type	Message
4	ORDERS	Initial PO
5	ORDCHG	PO Change
6	ASN	Advance Ship Notice
7	SCHREL	Supplier Schedule

Automating the Trade Sales Process

To completely automate the trade sales process, including importing and exporting ASNs, use the following procedure:

- 1 In eCommerce Manager (35.5), set these fields:
 - Export ASN to Yes
 - Import Files to Yes
 - Export Supplier Schedules to Yes
 - All other fields to No
- 2 Specify the number of hours you want EDI eCommerce to run.
- 3 Specify the intervals at which EDI eCommerce checks for documents that require exporting or importing.

Deleting Trade Sales Schedule Releases

Use Customer Plan Schedule Maint (7.5.1) or Customer Ship Schedule Maint (7.5.2) to delete a customer trade sales schedule. When you delete the customer schedule, the system deletes the matching supplier schedule, as long as the system has not exported or printed the supplier schedule.

If the system exported or printed the supplier schedule, it does not delete it, and you cannot delete the customer schedule. The system displays an error message in Customer Plan Schedule Maint and Customer Ship Schedule Maint if you try.

Product Information Resources

QAD offers a number of online resources to help you get more information about using QAD products.

[QAD Forums \(community.qad.com\)](http://community.qad.com)

Ask questions and share information with other members of the user community, including QAD experts.

[QAD Knowledgebase \(knowledgebase.qad.com\)*](http://knowledgebase.qad.com)

Search for answers, tips, or solutions related to any QAD product or topic.

[QAD Document Library \(documentlibrary.qad.com\)](http://documentlibrary.qad.com)

Get browser-based access to user guides, release notes, training guides, and so on; use powerful search features to find the document you want, then read online, or download and print PDF.

[QAD Learning Center \(learning.qad.com\)*](http://learning.qad.com)

Visit QAD's one-stop destination for all courses and training materials.

*Log-in required

Index

Numerics

1.4.1 163
1.16 163
1.19 163
2.1.1 23
5.5.1 171
5.5.1.1 99, 123
5.5.1.13 23, 100, 125
5.5.1.14 167
5.5.1.15 98
5.5.1.16 98
5.5.1.17 108, 127
5.5.1.21 98, 108
5.5.1.24 98
5.5.3 171
5.5.3.1 165, 176
5.5.3.4 181
5.5.3.5 181
5.5.3.8 105, 111, 134
5.5.3.9 111, 134
5.5.3.13 181
5.5.3.15 139, 181
5.5.3.17 181
5.5.3.23 140
5.5.5.11 114
5.5.5.13 115
5.5.5.14 115
5.5.7.1 123
5.5.7.4 124
5.5.7.6 132
5.5.7.7 132
5.5.7.13 139
5.5.7.14 138
5.5.7.24 121
5.19 104
7.3 171
7.3.1 23, 24
7.3.6 24
7.3.10 26
7.3.11 25
7.3.13 24, 31, 81, 163
7.3.23 163
7.3.24 21, 23, 27
7.5.1 44, 49, 21
7.5.2 44, 49
7.5.3 21, 48, 49
7.5.4.1 75, 73
7.5.4.5 77
7.5.4.6 80
7.5.4.7 80
7.5.4.10 86

7.5.4.13 80, 81
7.5.4.16 80
7.5.4.17 80
7.5.4.22 79
7.5.4.24 73
7.5.5 24, 36, 49, 83
7.5.6 24, 36, 49, 85
7.5.18 57
7.7.5 89
7.9.1 86
7.9.2 87
7.9.4 89
7.9.5 89, 91
7.9.8 89
7.9.16 57
7.9.20 89
7.9.21 90, 91
7.9.22 76, 77
7.9.24 23, 171
7.13.4 90
7.13.12 91
7.13.13.3 64
35.1 49, 77
35.4.3 90
35.4.8 111, 134
35.13.10 135, 163, 169
35.15.13 179
35.21.1 77
35.21.4.1 90
36.4.6 28
36.4.10 30

A

accounts payable (AP), variance reporting 113
addresses for docks 24
advance ship notice (ASN)
 Customer Plan Schedule Maintenance 45
 determining process 168
 documents created when imported 170
 exporting to customers 172
 importing 170
 overview in trade sales 9
 queueing for export to customer 169
 scheduled shipments 53
 supplier schedules 113
Application document definition 168
archive/delete
 schedule orders 116
 supplier scheduled orders 116
 supplier schedules 140
 trade sales orders 173

- ASN. *See* advanced ship notice (ASN)
- authorization numbers 28
 - category for 28
 - required ship schedule generation 50
 - schedule import 44
 - schedule maintenance 47
 - shipment pegging 55
 - unique days for 37
- automatically exporting schedules 182
- B**
- Bill of Lading Print
 - customer schedules 54
- billing in trade sales 11
- bucketing
 - customer schedules 46
 - supplier planning schedules 129
 - supplier schedules 112, 129
 - supplier shipping schedules 129
- C**
- calendar options
 - creating RSS from options 48
 - with netting logic and RSS 20
- calendars
 - customer 23
 - supplier 99, 123
- capturing data from import 179
- category, requirement detail 28
- Check Sequence Tolerance 78
- Check Sequence Tolerance field 74
- Closed Invoice Reprint
 - invoice history 35
- closing scheduled orders 116
- complete automation of trade sales 183
- Config Msg Verif Report 30
- Configured Message Maintenance 28
 - field descriptions 30
- configured messages
 - advance ship notice (ASN) 28
 - sample execution files 29
 - setting up 30
- consigned trade sales orders 168
- Consignment field in scheduled order 168
- Container Workbench
 - customer schedules 52
- Container/Shipper Control 23, 171
- containers, supplier schedules 114
- control programs
 - Customer Schedules 27
 - Purchasing 114
 - Sequence Schedules 73
 - Supplier Schedule 121
 - Supplier schedules 98
 - Trade Sales 163
- copy of ASN 168
- copying a scheduled line 103
- correcting trade sales orders 173
- cost update for scheduled orders 104
- creating customer schedules 179
- cross-references for items 164
- Cum Received Reset to Zero 115
- Cum Shipped Reset 57
- Cumulative Received Maintenance 115
 - cumulative reset
 - customer scheduled orders 57
 - supplier scheduled orders 115
- Cumulative Shipped Maintenance 57
- customer calendar
 - customer-specific calendar 23
 - excess quantities resolved 42
 - open days 19
 - specifying for RSS 36
 - with required ship schedule 23
- Customer Calendar Maintenance 23
- Customer Controls Maintenance 73, 75
- Customer Data Maintenance 23
- Customer Item Maintenance 163
- Customer Order Period Maintenance 24
- Customer Plan Schedule Maintenance 21, 44, 49
- customer planning schedule
 - automatic export 182
 - creating 179
 - deleting 183
 - exporting for trade sales 177
 - importing 179
 - overview in trade sales 176
 - processing 178
 - queuing 177
 - updating non-active 179
- customer receipt quantities 24
- customer records for trading partner parameters 176
- Customer Scheduled Order Maintenance 24, 81
 - creating 31
 - frames 31
 - referencing sequence lines 81
- customer scheduled order, trade sales 9
- customer schedules
 - bucketing 46
 - order setup 31
 - dynamic unpeg 33
 - netting logic 42
 - non-cumulative quantity accounting data frame 37
 - ship/delivery patterns (SDP) 42
 - standard pack quantity 41
 - transport days 33
 - week offset 32
 - processing 22, 43
 - calculations 49
 - entering releases 44
 - requirement detail 50
 - requirement detail categories 28
 - resetting cumulative totals 57
 - retobilling 59
 - setting up 22
 - shipment processing 51
- Customer Schedules Control 21, 23, 27
- Customer Schedules Setup Menu 171
- Customer Sequence Schedule Control 73
- customer sequence schedules
 - characteristics 70
 - defaults 75
 - overview 70
- Customer Ship Schedule Maintenance 44, 49
- customer shipping schedule
 - automatic export 182
 - creating 179
 - importing 179

- importing for trade sales 177
- overview in trade sales 176
- processing 178
- queuing 177
- updating non-active 179
- customer trade sales order 165
- customer trading partner parameters 169
- Customer/Ship-To field 23
- Customers Non-Work Days frame 23
- customizing messages for shippers 28

D

- deactivating sequences 79
- default customer calendar 23
- defaults for Consignment field 168
- delete/archive
 - customer planning/shipping schedule 183
 - supplier scheduled orders 116
 - supplier schedules 140
 - trade sales orders 173
 - trade sales scheduled order lines 173
- Dock Maintenance 24
- Document 830 Planning Schedule 49
- Document 862 Shipping Schedule 49
- Document Import 77
- Document Import, sequence schedules 77
- dynamic unpeg 33

E

- EC subsystem definition 168
- eCommerce Import 49
- eCommerce Manager
 - automatically exporting queued schedules 182
 - automating trade sales process 172
 - running for trade sales 172
 - setting polling frequency 172
- EDI eCommerce
 - queued entries 177
 - settings for trade sales 168
 - summary of changes 12
- EDI eCommerce Implementation Definition
 - Maintenance 179
- Enable Shipping Schedule field 180
- End Effective header field 101
- End Effective line field 107
- example of netting logic 18
- excess calendar quantities 42
- exchange file definition 168
- Export ASNs field 172
- export message type 182
- Export Supplier Schedules field 182
- exporting
 - ASNs to trade sales customers 172
 - schedules 177

F

- fabrication data 181
- fabrication data in supplier schedules 180
- faxing supplier schedules 137

H

- horizons, schedule 4

I

- implementation definition 168
- import data, capturing 179
- Include Sequence Schedule in RSS field 74
- Invoice Export, customer sequence schedules 90
- Invoice Post and Print 90
- Invoice Post, and customer sequence schedules 90
- Invoice Print or Reprint 91
- item cross-references 164
- Item Master Maintenance 163
- item number in supplier schedules 180
- Item Planning Data frame 164
- Item Rev Date field, scheduled orders 103

J

- just-in-time (JIT), in scheduled order management 2

M

- material requirements planning (MRP)
 - allocating scheduled order percentages for 127
 - customer schedules effect 41, 51
 - supplier schedules effect 109
 - supplier schedules update from 128
- memo type item
 - receiving 113
 - specifying in orders 103
- message type for supplier schedules 182
- messages
 - as verification 28
 - configured 28
 - setting up 28
- MRP % allocation, with effective dates 108
- MRP. *See* material requirements planning (MRP)
- multi-database mode 165

N

- netting logic
 - example 18
 - example with ship/plan PCR 21
 - PCR quantities 21
 - specifying options 18
- new supplier schedule release 179
- non-active customer schedules 179

O

- open days on calendars 19
- operating days 19
- operation, specifying code 104
- options for netting logic 42
- Order End Effective Report 98
- order periods, customer 24
- order processing 162
- Order Rev Date field, scheduled orders 101
- original ASN 168

P

- PCR quantities 21
- pegging
 - requirement detail for customer schedules 54
 - ship line requirements 56
- Picklist/Pre-Shipper–Automatic 86
 - pegging requirements 55
- Plan/Ship Sequence Variance Report 80
- planning and shipping schedule resolutions 42

- PO Line field in trade sales order 167
 - PO Number field in trade sales order 167
 - PO shipper
 - automating generation 9
 - contents in trade sales 171
 - creating from ASN import 12
 - PO Shipper Maintenance
 - supplier scheduled receipts 114
 - PO Shipper Receipt 114
 - PO shipper receipt
 - confirming 114
 - fixed prices 114
 - recording temporary inventory 171
 - Polling Frequency Per Hour field 172
 - Pre-Shipper/Shipper Confirm 89, 91
 - customer schedules 51
 - pegging requirements 56
 - Pre-Shipper/Shipper Print 89
 - Pre-Shipper/Shipper Workbench 87
 - pegging requirements 56
 - using with customer sequence schedule lines 87
 - Printer Setup Maintenance, shipping labels 25
 - prior cumulative date in supplier schedules 180
 - PRO/PLUS 70, 118
 - process overview 9
 - processing schedules 178
 - processing the trade sales order 162, 170
 - Purchase Order Cost Update 104
 - Purchase Order Receipts, supplier schedules 114
 - purchase order types contrasted 119
 - Purchasing Control
 - receiving documents 114
- Q**
- queue ASNs for export 169
 - Queue Trade Sales ASN field 169
 - Queue TS Schedules field 177
 - queued entries in EDI eCommerce 177
- R**
- raw authorization data
 - for trade sales 181
 - in supplier schedules 180
 - receipts
 - authorization numbers tracked 28
 - customer 45
 - for trade sales 9
 - quantities and dates 24
 - shipment processing 53
 - supplier schedules 112
 - with fixed prices 113
 - receiving memo type items 113
 - receiving scheduled orders with fixed prices 113
 - referencing sequence schedule lines 81
 - release authorization number (RAN) data 171
 - release ID, new supplier schedule 179
 - remote site for trade sales 165
 - required ship schedule
 - overview 18
 - required ship schedule (RSS)
 - including sequence schedule lines 83
 - netting logic and calendar options 20
 - netting logic for sequences 83
 - new calendar options 48
 - running 48
 - specifying a calendar for 23
 - using customer calendars 23
 - Required Ship Schedule Maintenance 21, 48, 49
 - Required Ship Schedule Update 24, 36, 49, 83
 - requirement details in supplier schedules 181
 - restrictions on Order Revision field 101
 - Retrobill Auto Create 66
 - Retrobill Control 61
 - Retrobill Include/Exclude Invoice 62
 - Retrobill Report 64
 - retrofills
 - debit/credit invoices by line or order 65
 - defining terms 63
 - manually entering a debit/credit number 64
 - setting up 62
 - role of tier-one supplier 9
 - RSS Calendar Option field 24
 - RSS. *See* required ship schedule
 - RSS. *See* required ship schedule (RSS)
 - running required ship schedule 48
- S**
- sales order shipper
 - dock addresses 25
 - maintaining sequences 89
 - using with customer sequence schedules 89
 - with customer schedules 51
 - Sales Order Shipper Maintenance 89
 - Schedule Authorization Report 181
 - quantities 48
 - Schedule Comparative 139
 - Schedule Comparative Report 181
 - Schedule Delete/Archive 140
 - Schedule History Inquiry 181
 - Schedule Inquiry 181
 - Schedule Order Default field 74
 - Schedule Print 105, 111, 134, 136
 - Schedule Print in Fax Format 111, 134, 137
 - schedule processing overview 176
 - schedule releases, overview in trade sales 10
 - Schedule Report 181
 - resource authorizations 41
 - Schedule Update from MRP 165, 176
 - bucketing requirements 129
 - calculations 110, 130
 - firm days 104
 - firm days effect 128
 - report options 131
 - scheduled order
 - active and inactive 97
 - allocation percentages 108
 - characteristics 96
 - effective date processing 97
 - firm requirements 110
 - Item Rev Date field 103
 - line items 102
 - Order Rev Date field 101
 - receiving 112
 - receiving with fixed prices 113
 - sequenced scheduled orders 81
 - zero quantity and cost update 104
 - Scheduled Order Inquiry 167
 - scheduled order management 1–13

- Scheduled Order MRP % Maintenance 108, 127
- Scheduled Order Report 98
- schedules
 - overlapping 4
 - overview 3
 - planning 4
 - shipping 3
 - updating 5
- SDP. *See* ship/delivery pattern (SDP)
- SDT. *See* ship/delivery time (SDT)
- Selective Req Ship Sched Update 49
- Selective Required Ship Schedule Update 85
- Send EDI ASNs field 169
- Send EDI Plan Schedules field 177
- Send EDI Ship Schedules field 177
- Sequence Cross-Ref Maintenance 80
- Sequence Cross-Reference Report 81
- Sequence Pre-Shipper–Automatic 86
- Sequence Schedule Detail Delete 79
- Sequence Schedule Inquiry 80
- Sequence Schedule Maintenance 77, 79
 - Sequence Detail Data frame 79
- Sequence Schedule Report 80
- Sequence Schedule Variance Report 80
- sequence schedules
 - duplicate requirements 80
 - modifying 77
 - reports 80
 - with trade sales 34
 - workflow 7
- Sequenced field 34, 166
- sequenced schedules and trade sales 166
- Sequences Per Container 78
- setting up
 - configured messages 29
 - customer calendars 23
 - customer order periods 24
 - customer schedules 6, 22
 - items for trade sales 164
 - retro bills 62
 - sequence schedules 7
 - supplier calendars 123
 - supplier schedules 98, 121
 - supplier-specific data for EDI 135
 - trade sales 162
 - trading partner parameters 169
- severity level, configured messages 31
- ship delivery time ((SDT) 123
- Ship Delivery Time Maintenance 123
- Ship Schedule Variance Compare 139
- Ship to Cum/Req field 21
- Ship to Plan Schedule Compare 138
- ship type 167
- ship/delivery patterns (SDP) 42
- Shipment ASN Export 90
 - including customer sequence schedule information 90
- shipment of materials 11
- shipper
 - and bill of lading 54
 - configured messages 28
 - confirming 53
 - container subsets 114
 - containing sequence information 86
 - containing sequences 86
 - defining 52
 - disabling pegging 55
 - editing before confirm 52
 - in trades sales process 11
 - maintaining pegged lines 56
 - pegging 6
 - printing 53
 - printing sequence numbers 75
 - replacing with labels 25
 - verifying 22, 28
- shipper confirmation, automatic 9
- Shipper Gateway 77
 - and customer sequence schedule information 76
 - pegging requirements 55
- Shipper Unconfirm 90, 91
- shipping calendar, open days 19
- shipping detail data in supplier schedules 180
- Shipping Label Definition Maintenance 25
 - template values 25
- shipping labels 25
 - supplier scheduled receipts 113
- Ship-To field in trade sales order 165
- Site Ship-from ID Maintenance 26
- SO Container Maintenance 89
 - using with customer sequence schedules 89
- SO shipper
 - automating generation 9
 - creating from ASN import 12
 - from inbound ASN 171
- SO shipper confirmation 171
- SO shipper ID 171
- specific calendar for customer 23
- standard pack quantity 107
- Start Effective header field 100
- subcontract items, reports 181
- Subcontract Order MRP % Maintenance 98, 108
- subcontract visibility 181
- supplier ASN 168
- supplier calendar 99, 123
- Supplier Calendar Maintenance 99, 123
- Supplier Controls Maintenance 124
- Supplier field in trade sales order 167
- Supplier Item Maintenance 163
- supplier planning schedule
 - automatic update 132
 - bucketing 129
 - data entry 132
 - exporting 135
 - modifying 132
 - type 118
- Supplier Planning Schedule Maintenance 132
- supplier planning schedules in trade sales 9
- supplier records for trading partner parameters 176
- Supplier Schedule Control 98, 121
- supplier scheduled order
 - creating 100
- Supplier Scheduled Order Maintenance
 - calendar options 23
 - header frame 100
 - Order Line Item Data frame 102
 - role in trade sales 100
 - setting up 125
 - Shipping Schedule Info pop-up 126
- supplier schedules 95–116

- bucketing 112, 129
 - defined 96
 - manually modifying 132
 - order receipt 112
 - ASN 113
 - confirming shipments 114
 - invoices 113
 - receiving document 113
 - shipment IDs 114
 - shipping labels 113
 - orders
 - Cum Start field 107
 - firm days 104
 - resetting cumulative received 115
 - schedule days 105
 - schedule months 105
 - schedule weeks 105
 - standard pack quantity 107
 - transport days 105
 - processing 109, 128
 - transmitting scheduled releases 111, 134
 - setting up 98
 - control values 121
 - MRP percentages 127
 - supplier calendars 99, 123
 - supplier control data 124
 - Supplier Schedules Menu 120
 - Supplier Schedules Processing Menu 171
 - Supplier Schedules Setup Menu 171
 - Supplier Shipping Schedule 111, 134
 - Supplier Shipping Schedule Control 180
 - Supplier Shipping Schedule Maintenance 132
 - supplier shipping schedules 118–140
 - bucketing 129
 - in trade sales 9
 - updating plan from ship 122
 - supplier trading partner parameters 169
 - suppliers, defining for trade sales 164
 - system 34, 166
- T**
- tier-one supplier, role 9
 - tolerance
 - checking sequence schedule gaps 74
 - trade sales 161–173
 - ASN processing 11
 - basic functionality 162
 - billing 11
 - complete automation 183
 - corrections 173
 - defining suppliers for 164
 - deleting order lines/order 173
 - graphic overview 9
 - overview of order process 170
 - setting up for order processing 162
 - setting up the order 165
 - viewing documents 171
 - viewing schedules 181
 - with sequenced schedules 34, 166
 - Trade Sales Control 163
 - Trade Sales field 165
 - Trade Sales PO Data frame 165
 - Trading Partner Parameter Maint 135, 169
 - trading partner records for customers and suppliers 176
 - transformation definition 168
 - trq_mstr table 182
 - turnaround data feature 179
 - Type field 167
- U**
- Undo Shipper Number Assignment 89
 - Use Ship/Plan PCR field 21
- V**
- viewing
 - customer requirements 46
 - scheduled order data 43
 - sequences from pre-shipper 87
 - subcontract operations 181
 - trade sales data 165
 - trade sales schedules 181
 - variances between schedules 70
- W**
- work order ID
 - automatic update 104
 - specifying 104
 - with advanced repetitive processes 104
 - workdays, specifying for customer calendar 23
- Z**
- zero requirements, generating 131
 - zero schedule
 - as supplier shipping schedule 98
 - automatic generation 101
 - definition 101
 - setting the default 98
 - specifying 101
 - Zero Schedules field 101