



QAD Enterprise Applications  
Enterprise Edition

# Administration Guide

# QAD System Administration

Introduction to System Administration  
Domain Constants  
System Interface  
Printers  
Batch Processing and Daemons  
System Control  
CIM Interface  
Database Management  
Reports and Utilities  
Customizing Business Logic  
Customizing Specific Business Components  
UI Customization  
Installing Electronic Bank File Formats

70-3184-2016EE  
QAD Enterprise Applications 2016  
Enterprise Edition  
March 2016

This document contains proprietary information that is protected by copyright and other intellectual property laws. No part of this document may be reproduced, translated, or modified without the prior written consent of QAD Inc. The information contained in this document is subject to change without notice.

QAD Inc. provides this material as is and makes no warranty of any kind, expressed or implied, including, but not limited to, the implied warranties of merchantability and fitness for a particular purpose. QAD Inc. shall not be liable for errors contained herein or for incidental or consequential damages (including lost profits) in connection with the furnishing, performance, or use of this material whether based on warranty, contract, or other legal theory.

QAD and MFG/PRO are registered trademarks of QAD Inc. The QAD logo is a trademark of QAD Inc.

Designations used by other companies to distinguish their products are often claimed as trademarks. In this document, the product names appear in initial capital or all capital letters. Contact the appropriate companies for more information regarding trademarks and registration.

Copyright ©2016 by QAD Inc.

SysAdmin\_AG\_v2016.pdf/yimg/yimg

**QAD Inc.**

100 Innovation Place  
Santa Barbara, California 93108  
Phone (805) 566-6000  
<http://www.qad.com>

# Contents

## System Administration

Change Summary .....	xi
----------------------	----

## Chapter 1 Introduction to System Administration.....1

System Administration Overview .....	2
Types of Functions .....	3
Domain Constants .....	3
System Interface .....	3
Printers .....	3
Batch Processing and Daemons .....	4
System Control .....	4
CIM Interface .....	4
Database Management .....	4
Reports and Utilities .....	4
Customizing Component-Based Functions .....	5

## Chapter 2 Domain Constants.....7

Overview of Domain Constants .....	8
Maintaining Shop and Holiday Calendars .....	8
Using Calendar Levels .....	8
Defining Calendars .....	9
Setting Up Calendar Exceptions .....	15
Setting Up Full-Day Exceptions .....	16
Defining Holidays .....	17
Using Generalized Codes .....	18
Field Validation .....	18
Generalized Codes Groups .....	20
Using Reason Codes .....	22
Managing Number Ranges .....	23
NRM Overview .....	23
Sequence Life Cycle .....	25
NRM Sequences .....	25
Setting Up Sequences .....	27
Setting Sequence Values .....	32
Defining Sequences for Sales Orders .....	33

Viewing Sequence Number History .....	33
Deleting and Archiving Sequences .....	33
Tracking Changes .....	34
Change Tracking Implementation Overview .....	34
Defining Change Tracking Reason Codes .....	35
Activating Change Tracking .....	35
Specifying Fields to Track .....	35

**Chapter 3 System Interface .....39**

Overview of User Interface .....	41
Using Multiple Languages .....	45
Multiple Languages and Unicode .....	46
Setting Up Multiple Languages .....	47
Language Detail Maintenance .....	47
Report Translation .....	48
Customizing Menu Information .....	49
Executing Menu Items .....	49
Menu Structure .....	50
Menus and Security .....	50
Menu System Maintenance .....	51
Setting Up Menu Substitutions .....	52
Defining Program Information .....	52
Viewing Business Components .....	54
Modifying Messages .....	55
Creating and Managing Browsers .....	56
Maintaining Drill Downs and Lookups .....	56
Creating Access to Other Programs .....	59
Managing Stored Searches .....	61
Defining Browse URL Links .....	61
Creating Browsers .....	66
Creating Views .....	70
Defining User Menu and Function Keys .....	73
User Menu .....	73
Executing Programs in Sequence .....	74
User Function Maintenance .....	74
Using Field and Program Help .....	74
Adding User Help .....	75
Printing Help .....	75
Setting User Telnet Options .....	75
Configuring Telnet Server Settings .....	76
Define the Login Sequence Script Lines .....	76
Configure Telnet Connection Settings .....	78
Verify the Login Sequence .....	79

Modifying Labels .....	79
Building an E-Mail System Interface .....	80
Setting Up E-Mail System Interfaces .....	80
Using Text E-Mail .....	80
E-Mailing Attachments .....	80
E-Mail Definition Maintenance .....	81
E-Mail Command Parameters .....	82
Customizing Appearance of HTML E-Mail .....	82
Configuring E-Mail Notification for Components .....	82
Using Advanced Reporting Tools .....	83
QAD-Provided Dashboards .....	84
Custom Reports and Dashboards .....	84
Monitoring User Sessions .....	84
<b>Chapter 4 Printers.....</b>	<b>87</b>
Introduction to Printer Management .....	88
Defining Printer Types .....	88
Setting Up Printers .....	90
Defining a Printer for Use with QAD .NET UI .....	92
Setting Default Printers .....	92
Defining Document Formats .....	92
<b>Chapter 5 Batch Processing and Daemons.....</b>	<b>95</b>
Introduction to Batch Processes and Daemons .....	96
Batch Processes .....	96
Define Batch IDs .....	96
Review Batch Jobs .....	97
Process Batch Request .....	97
Invoke Batch Processing from CIM .....	98
Daemons .....	99
Overview of Daemon Processing .....	100
Daemon User .....	101
Types of Daemon .....	101
Daemon Permissions .....	106
Daemon Functions .....	106
Event Daemon .....	117
Report Daemon .....	120
XML Daemon .....	123
Queue View .....	125
Queue Correct .....	126
Queue Delete .....	127
Running Daemons on the Command Line .....	128

Integrating XML Documents .....	128
Planning the Integration .....	128
Identifying Business Components .....	129
Business Component Structures .....	130
Tables and Mandatory Fields .....	131
Component Schema and Sample Files .....	132
Creating the XML File .....	134
Integrating Multiple Records in an XML Document .....	138
Processing the XML File .....	138
Bulk Data Load .....	139
<b>Chapter 6 System Control .....</b>	<b>143</b>
System Control Overview .....	144
Database Control .....	144
System Maintenance .....	145
Maintain .....	145
Synchronize .....	148
View System Codes .....	149
System Monitor .....	150
Set Debug Level .....	151
View CT Logfile .....	153
server.xml .....	154
Configuring System and User Settings .....	154
System Settings .....	154
User Settings .....	157
Making UI Caching Configurable .....	158
Configuring Workflow .....	159
Managing Draft Objects .....	159
<b>Chapter 7 CIM Interface .....</b>	<b>161</b>
Introduction to CIM .....	162
Using the CIM Interface .....	162
CIM Data Format .....	164
Input File Formatting Rules .....	164
Input Data Types .....	165
Determining Data for the Input File .....	165
CIM Data Input File Example .....	166
Creating a CIM Input File .....	166
Error Handling .....	168
Deleting Records through CIM .....	168
Creating Input Files to Delete Records .....	169
Example of CIM Delete .....	169

Clearing a Field Value .....	169
Running Multiple CIM Sessions .....	169
Killing CIM Sessions .....	169
<b>Chapter 8 Database Management .....</b>	<b>171</b>
Managing Database Size .....	172
Determining Disk Usage .....	172
Freeing Disk Space .....	172
Dumping and Loading Data .....	173
Dump/Load Procedures .....	173
Deleting and Archiving Data .....	174
GL Audit Detail Delete/Archive .....	175
GL Transaction Delete/Archive .....	175
Logon History Archive/Delete .....	177
Restoring Archive Files .....	178
Journal Entry Archiving .....	179
Integrity Logging .....	179
Registering Licenses .....	180
Licensing Overview .....	180
License Registration .....	183
License Reporting .....	185
Managing Database Sequences .....	190
Initializing Sequences .....	191
Maintaining Sequences Manually .....	191
Maintaining Sequences Using CIM .....	192
Maintaining Audit Trails .....	193
Maintaining Sequences in Oracle .....	193
Component Record Numbering .....	194
Setting Up Multiple Time Zones .....	196
Multiple Time Zones Maintenance .....	196
Multiple Time Zone Load Utility .....	198
Setting a Default Time Zone .....	199
Domain Time Zone .....	199
UTC and Transactions Outside Domains .....	199
<b>Chapter 9 Reports and Utilities .....</b>	<b>203</b>
Generating Auditing Reports .....	204
Other Reports .....	204
Using System Cross-References .....	204
Background .....	205
Table, Field, and Menu Reports .....	205
Using Program Reports .....	206

Updating the Cross-Reference .....	208
Setting Up Application Servers .....	208
Progress Application Server .....	208
Using an Application Server to Run MRP (Example) .....	209
Using Operating System Commands .....	211
Using Delete/Archive Utilities .....	212
Audit Detail Delete/Archive .....	212
Statutory-Currency Utility .....	212
Choosing the Best Time to Run the Utility .....	212
Running the Utility .....	213
Restrictions .....	214
Command Line Application Control .....	214
<b>Chapter 10 Customizing Business Logic .....</b>	<b>219</b>
Introduction to Customization .....	220
Customization Overview .....	220
Supporting Documentation .....	221
Elements of Customization .....	221
Parameters .....	222
Datasets .....	222
Accessing Generalized Codes and Master Comments .....	224
Generalized Codes .....	224
Master Comments .....	225
Error Handling .....	225
Database Access and Updates .....	226
Inheritance .....	226
Identifying Events .....	226
Sample Code for Non-Intrusive Customization .....	230
Creating Customizations .....	231
Writing Customizations .....	232
Compiling Customizations .....	232
Updating Customizations .....	232
Running Other Business Methods .....	233
Examples of Customization .....	233
<b>Chapter 11 Customizing Specific Business Components .....</b>	<b>235</b>
Customizing Process Incoming Bank Files .....	236
Customer Payments in Bank File Import Lines .....	236
Setting Up Customization .....	245
Enabling and Disabling the Customizable Matching Logic .....	245
Customizing the Validation of Tax IDs .....	245
Validation Component .....	246

Errors and Warnings .....	247
Customization Sample Code .....	247
<b>Chapter 12 UI Customization .....</b>	<b>249</b>
Overview .....	250
Design Mode .....	250
Settings that Affect Design Mode .....	250
Starting Design Mode .....	252
Working in Design Mode .....	257
Customize Views .....	260
Delete Customizations .....	263
Exporting Customizations .....	264
Importing Customizations .....	265
User-Defined Fields .....	265
Create a User-Defined Field .....	266
UDFs and Design Mode .....	268
Modifying UDFs .....	269
Adding Fields to Financials QRF Reports .....	269
User-Defined Components .....	272
Elements of User-Defined Component Implementation .....	273
User-Defined Components Maintain .....	274
Example of User-Defined Component .....	275
Non-Intrusive Customization .....	275
Creating a New Component .....	275
Financial Text Translation .....	289
<b>Chapter 13 Installing Electronic Bank File Formats .....</b>	<b>291</b>
Introduction to Electronic Banking Format Installation .....	292
Setting up EDI eCommerce to Use Imported Bank Formats .....	292
Using Bank File Format Import to Install the Format .....	295
Default Directory Settings .....	297
<b>Product Information Resources .....</b>	<b>299</b>
<b>Index .....</b>	<b>301</b>



# System Administration Change Summary

The following table summarizes significant differences between this document and previous versions.

<b>Date/Version</b>	<b>Description</b>	<b>Reference</b>
March 2016/2016 EE	Revised section on Maintaining Shop and Holiday Calendars	page 8
	Removed inaccurate bullet point referring to DataSync	page 128
	Added new bullet to the introductory section of Integrating XML Documents to reference integration using EDI eCommerce	page 128
	Added new section to CIM Interface topic on Clearing a Field Value	page 169
	Updated the section title and text references from “Audit Detail Delete/Archive” to “GL Audit Detail Delete/Archive”	page 175
	Added new section on GL Transaction Delete/Archive	page 175
	Added new section on Logon History Delete/Archive	page 177
	Moved section on GL Transaction Delete/Archive (36.23.2) from the Reports and Utilities chapter and consolidated the information within the new GL Transaction Delete/Archive section in “Deleting and Archiving Data”	page 175 page 212
March 2015/2015 EE	Added new section on Customer Invoice Numbering	page 30
	Updated the Batch Processing and Daemons chapter to reflect changes to daemon functionality.	page 95
	Made minor change to the description of the Payment Selection Confirm Batch Size field in System Maintain	page 147
	Added new section on Bulk Data Load functionality	page 139
	Added new section on Financial Text Translation	page 289
March 2014/2014 EE	Added section on server.xml	page 154
	Miscellaneous minor changes	
September 2013/2013.1 EE	Added new section on the Statutory-Currency Utility	page 212
	Miscellaneous minor changes	--
March 2013/2013 EE	Added section on Adding Another URL for the Same Browse	page 62
	Updated the Primary Key Fields section	page 138
	Updated System Maintain section for new fields	page 145
	Added section on Determining the Optimal Payment Selection Confirm Batch Size	page 148
	Added section on Adding Fields to Financials QRF Reports	page 269
September 2012/2012.1 EE	Rebranded for QAD 2012.1 EE	--
March 2012/2012 EE	Added new section on Generalized Code Group	page 20

<b>Date/Version</b>	<b>Description</b>	<b>Reference</b>
	Added description for new Cube daemon	page 101
	Added descriptions for four new fields in System Maintain	page 145
	Removed reference to Master Data Audit Detail report, which was removed from the menu	page 204
September 2011/2011.1 EE	Rebranded for QAD 2011.1 EE	--
	Updated sentence that refers to default settings	--
	Updated the introduction to Exporting Customizations to list the filenames to which customizations are exported	page 264
	Updated screenshot and field descriptions to show new Folder Name field in Export UI Customization	page 264
	Updated screenshot and field descriptions to show new Folder Name field in Import UI Customization	page 265

# Introduction to System Administration

***System Administration Overview 2***

Discusses required setup tasks and common administrative tasks.

***Types of Functions 3***

Explains which functions are included with the system.

***Domain Constants 3***

Discusses programs on the Domain Constants menu.

***System Interface 3***

Discusses programs on the System Interface menu.

***Printers 3***

Discusses programs on the Printer Management menu.

***Batch Processing and Daemons 4***

Discusses programs on the Batch Processing/Daemon menu.

***System Control 4***

Discusses programs on the System Control menu.

***CIM Interface 4***

Discusses how CIM can be used.

***Database Management 4***

Explains how the system allows database management functions to be performed.

***Reports and Utilities 4***

Discusses reports and utilities available on the System Administration menu.

***Customizing Component-Based Functions 5***

Explains how to customize component-based functions.

## System Administration Overview

As part of any initial implementation, you must perform a number of setup tasks, including the following:

- Set up system-wide data such as generalized codes, printers, batch queues, menus, messages, and language code.
- Define users and security. For more information on users and security, see *QAD Security and Controls User Guide*.
- Set up the basic corporate structure that forms the basis for all business activities. This setup includes shared address data; domains, which are sets of related business entities that share a common base currency and chart of accounts; entities; and other shared data. For more information on the corporate structure setup, see *QAD Financials User Guide*.  
**Note** Shared Services Domain is a separately licensed module. Unless you purchase appropriate licenses, the system prevents you from having more than one active domain per database.
- Define base data such as items, sites, and locations. For more information on items, sites, and locations, see *QAD Master Data User Guide*.

This book covers the first topic, setting up system-wide data, as well as common administrative tasks that are required in a running system. It is divided into two sections, reflecting these distinct activities:

- Database Setup, which includes domain constants, system interface, printers, batch processing and daemons, and configuring database settings.
- Database Administration, which includes the CIM interface, database management, and reports and utilities.

The System Administration menu includes tasks typically performed by system administrators. Most functions located on this menu (36) are discussed in this volume. However, a few areas are discussed in other volumes:

- Corporate Structure Setup (36.1). For more information on the corporate structure setup, see *QAD Financials User Guide*.
- Operational Accounting Controls (36.9) are described in the various user guides for the functional areas they affect.
- System Security (36.3) and Enhanced Controls (36.12). For more information on security and enhanced controls, see *QAD Security and Controls User Guide*.
- Configured Messaging (36.4.6.13) applies only to scheduled orders. For more information on Configured Messaging, see *QAD Scheduled Order Management User Guide*.
- Options on the External Interfaces menu (36.5) are discussed in the user documentation for the appropriate product area.

This volume does not cover the various utilities on the System Administration menus numbered above 24. For documentation of these programs, see the procedure help or the opening program screen of each utility.

## Types of Functions

The system includes both standard Progress programs and component-based functions. The component-based technology extends features of the user interface. These activities can be executed only from the .NET UI.

Because of differences in the underlying technology of the two types of programs, some administrative functions apply to one or the other, and some apply to both. For example, you set up menu locations for standard programs and component-based functions using Menu System Maintenance. However, batch setup applies only to standard programs and daemon setup applies only to component-based functions.

The type of program affected by an area of system administration is pointed out in the discussion of each system administration feature.

## Domain Constants

The programs on the Domain Constants menu (36.2) control calendars and codes used throughout the system. These include shop and holiday calendars, reason and generalized codes, and rounding methods. See “Domain Constants” on page 7 for details.

In addition, you can set up number sequences using number range management (NRM) functions, which support regulatory controlled document numbering. NRM controls the content and sequencing of a numeric series, as well as preventing gaps in a series.

Finally, you can specify fields in tables for detailed change tracking and reporting.

## System Interface

The System Interface menu contains programs that control menus, screen labels, messages, multi-language installations, and help. You can set up user function keys, define your e-mail system, and specify login scripts.

System interface functions include programs for creating browses and associating them with fields and programs, and managing stored browse data. In addition, you can also define alternate programs to execute when menu items are selected and specify programs to be run from other programs.

To meet specialized needs, you can set up user-defined fields for both standard programs and component-based functions.

See “System Interface” on page 39 for details.

## Printers

The Printer Management menu contains programs for setting up system printers, specifying default printers for a single user or all users, and creating batch print requests.

See “Printers” on page 87 for details.

## Batch Processing and Daemons

Use programs from the Batch Processing/Daemon menu to set up background jobs and manage and monitor daemon processes, which run in the background and perform required utility tasks when the system is being used.

See “Batch Processing and Daemons” on page 95 for details.

## System Control

The System Control menu contains critical control programs that must be set up before the system is used, that affect all users, domains, and entities.

See “System Control” on page 143.

## CIM Interface

CIM (computer integrated manufacturing) is one way to load legacy or non-Progress data into the QAD database. Using CIM, data can be added using standard program validation.

See “CIM Interface” on page 161 for details.

## Database Management

The system provides utilities for monitoring database size, performing dumps and loads, reloading archive files, and managing database sequences. Delete/archive followed by dump/load is the standard means of controlling database size and fragmentation in Progress databases.

User licensing utilities and programs for managing time zones are also included in database management.

See “Database Management” on page 171 for details.

## Reports and Utilities

A number of system-wide reports and utilities are provided on the System Administration menu.

The system cross-reference programs display information about field, program, and table relationships in your database. If you customize your implementation, this is an essential set of programs.

The system can use a Progress application server (AppServer) to run applications remotely. The AppServer must be defined first to make it available.

See “Reports and Utilities” on page 203 for details.

## Customizing Component-Based Functions

In addition to using such tools as Design Mode and user-defined fields to modify the way component-based QAD applications work, you also can customize business component code for an installed application using a standard Progress 4GL editor.

See “Customizing Component-Based Functions” on page 5.



# Domain Constants

The programs on the Domain Constants menu control calendars and codes used by various functions within a domain.

***Overview of Domain Constants 8***

Lists the programs on the Domain Constants menu.

***Maintaining Shop and Holiday Calendars 8***

Explains how to use Calendar Maintenance and Holiday Maintenance.

***Using Generalized Codes 18***

Discusses which conditions can be controlled with generalized codes, gives information on prerequisite field validation, and explains how to use generalized code groups.

***Using Reason Codes 22***

Explains how to use Reason Codes Maintenance.

***Managing Number Ranges 23***

Gives an overview of NRM, discusses number segment types, the sequence life cycle, NRM sequences, setting up sequences, setting sequence values, defining sequences for sales orders, viewing sequence number history, and deleting and archiving sequences.

***Tracking Changes 34***

Explains how to use Change Tracking Maintenance, gives an overview of change tracking implementation, and explains how to define change tracking reason codes, activate change tracking, and specify fields to track.

## Overview of Domain Constants

Domain constants provide basic data used by many system functions. Since a domain represents a distinct business operation, codes can be quite different between domains. If you need to use the same code in more than one domain, you must set it up for each domain that requires it.

Data that extends across the domain includes:

- Shop and Holiday Calendars; see page 8
- Generalized Codes; see page 18
- Reason Codes; see page 22
- Number Ranges; see page 23
- Change Tracking; see page 34

## Maintaining Shop and Holiday Calendars

The shop calendar is required for planning and manufacturing modules. The calendar indicates what days the plant is open and how many hours are worked each day. This information is used:

- To schedule start and due dates for MRP planned orders, master schedule orders, and work orders
- To schedule operations for work orders and repetitive schedules
- To schedule the procurement or shipment of materials through association with suppliers

**Note** Other Enterprise Edition functions have module-specific calendars. For example, Customer Schedules, SSM Engineers, and Fixed Assets do not use the shop calendar described here.

### Using Calendar Levels

You can define shop calendars on multiple, increasingly more specific levels—down to the individual machine if needed.

When scheduling, the system searches for a calendar from the most specific to the least specific.

Typically, you would define calendars in this sequence:

- 1 At the most general level, use Domain Calendar Maintenance (36.2.4.1). This is the only required calendar. It serves as the default calendar for all manufacturing functions if calendars are not set up for the site or at lower, more-specific levels.
- 2 To define a calendar for a site for which you do not want to use the domain calendar, use Site Calendar Maintenance. If no calendars are found at a lower level, manufacturing functions at this site look for this calendar.
- 3 The most specific calendars apply to:
  - Repetitive or Advanced Repetitive production lines, set up using Production Line Calendar Maintenance (18.1.22.1, 18.22.1.22.1)
  - Work center/machine combinations, set up using Work Center Calendar Maintenance (14.18.1)
  - Kanban processes, set up using Process Calendar Maintenance (17.1.13)

- Your suppliers, set up using Supplier Calendar Maintenance (5.5.1.1)
- 4 Use Holiday Maintenance (36.2.1) to define full-day holidays at the domain or site level. See “Defining Holidays” on page 17.
  - 5 Use calendar-specific exception programs to define additional or fewer available hours for specific calendar days at the domain, site, or lower level. For example, you might subtract hours for machine maintenance, or add hours for overtime. See “Setting Up Calendar Exceptions” on page 15.

## Defining Calendars

Basic setup is similar for all the calendar types:

- 1 Where applicable, use the selection fields to specify where the calendar applies.
- 2 Enter the number of hours scheduled on each day of the week for one or more shifts.

The following topics provide calendar-specific information.

### Domain Calendar

Use Domain Calendar Maintenance (36.2.4.1) to define the default calendar for the entire domain. Related programs are on the Domain Calendar Menu (36.2.4). Set up exceptions in Domain Calendar Exceptions Maint (36.2.4.4).

There are no selection fields; the system applies the calendar to the current working domain.

**Fig. 2.1**  
Domain Calendar Maintenance (36.2.4.1)

	Hours	Start Time	Productivity	Pattern
Sunday	0.00	00:00	100.00%	
Monday	8.00	00:00	100.00%	
Tuesday	8.00	00:00	100.00%	
Wednesday	8.00	00:00	100.00%	
Thursday	8.00	00:00	100.00%	
Friday	8.00	00:00	100.00%	
Saturday	0.00	00:00	100.00%	
Shift Total	40.00			
All Shifts	40.00			

**Shift.** Enter a code identifying the work shift associated with this calendar entry.

If you have just one shift, enter the information under Shift 1. The system considers each day with a positive number of hours as a work day.

**Hours.** Enter the number of work hours for this shift and day of the week. If you do not enter a number of hours, the system considers this a non-work day.

**Start Time.** Enter the time of day (based on a 24-hour clock) that this workday begins on the selected shift.

**Productivity.** When a shift is more or less productive than a normal shift (for example, because it has a larger or smaller crew), enter an adjustment. Less than 100% indicates a less productive shift; more than 100% indicates increased productivity.

**Example** A production line has three shifts, and the third shift has only 20% of the employees of the first two shifts. Enter a shift adjustment factor of 20% for that shift.

The system rates shift capacity as:

$$\text{Shift Capacity} = \text{Production Rate} * \text{Hours} * \text{Productivity}$$

**Note** This Productivity field has no connection to productivity measures elsewhere in the system.

**Pattern.** Optionally, identify a pattern that applies to this day on this shift, such as a recurring event. For example, you might add a code to indicate that two hours of maintenance is performed during shift 1 on the first Monday of each month. This could serve as a reminder to define a -2.0 hour exception.

This field is for reference only. It is not used in any system processing.

## Site Calendar

Use Site Calendar Maintenance (1.1.22.1) to define the default calendar for a specific site. Related programs are on the Site Calendar Menu (1.1.22). Set up exceptions in Site Calendar Exceptions Maint (1.1.22.4).

**Fig. 2.2**  
Site Calendar Maintenance (1.1.22.1)

	Hours	Start Time	Productivity	Pattern
Sunday	0.00	00:00	100.00%	
Monday	8.00	00:00	100.00%	
Tuesday	8.00	00:00	100.00%	
Wednesday	8.00	00:00	100.00%	
Thursday	8.00	00:00	100.00%	
Friday	8.00	00:00	100.00%	
Saturday	0.00	00:00	100.00%	
Shift Total	40.00			
All Shifts	40.00			

**Site.** Enter the site that this calendar applies to. This is a required field.

**Note** Time fields are the same as described for Domain Calendar Maintenance. See page 9.

**Production Line Calendar**

Use Production Line Calendar Maintenance (18.1.22.1, 18.22.1.22.1) to define the default calendar for a specific production line used in repetitive manufacturing. Related programs are on the Production Line Calendar Menu (18.1.22, 18.22.1.22). Set up exceptions in Production Line Cal Except Maint (18.1.22.3, 18.22.1.22.3). You also can use Production Line Non-Workday Update to define full-day exceptions; see page 16.

**Fig. 2.3**  
Production Line Calendar Maintenance (18.1.22.1, 18.22.1.22.1)

	Hours	Start Time	Productivity	Pattern
Sunday	0.00	00:00	100.00%	
Monday	8.00	00:00	100.00%	
Tuesday	8.00	00:00	100.00%	
Wednesday	6.00	00:00	100.00%	
Thursday	10.00	00:00	100.00%	
Friday	8.00	00:00	100.00%	
Saturday	0.00	00:00	100.00%	
Shift Total	40.00			
All Shifts	44.00			

*Site.* Enter the site that this calendar applies to. This is a required field.

*Production Line.* Enter the repetitive production line that this calendar applies to. This is a required field.

**Note** Time fields are the same as described for Domain Calendar Maintenance. See page 9.

**Work Center Calendar**

Use Work Center Calendar Maintenance (14.18.1) to define the default calendar for a specific work center, or work/center machine combination. Related programs are on the Work Center Calendar Menu (14.18). Set up exceptions in Work Center Calendar Excpt Maint (14.18.4). You also can use Work Center Non-Workday Update to define full-day exceptions; see page 16.

**Important** If you define calendars down to the machine level, note that exceptions with Machine left blank do not apply to machine-specific calendars. For example, you set up calendars for Work Center 100/Machine 1, Work Center 100/Machine 2, and Work Center 100/Machine [blank]. The system does not apply exceptions for 100/[blank] to the Machine 1 and Machine 2 calendars.

**Fig. 2.4**  
Work Center Calendar Maintenance (14.18.1)

	Hours	Start Time	Productivity	Pattern
Sunday	24.00	00:00	100.00%	
Monday	8.00	00:00	100.00%	
Tuesday	24.00	00:00	100.00%	
Wednesday	24.00	00:00	100.00%	
Thursday	24.00	00:00	100.00%	
Friday	24.00	00:00	100.00%	
Saturday	24.00	00:00	100.00%	
Shift Total	152.00			
All Shifts	152.00			

*Site.* Enter the site that this calendar applies to. This is a required field.

*Work Center.* Enter the work center that this calendar applies to. It must be associated with the specified site. This is a required field.

*Machine.* Optionally, enter the machine that this calendar applies to. Leave blank to apply the calendar to all machines in the work center, which is typical.

**Note** Time fields are the same as described for Domain Calendar Maintenance. See page 9.

### Kanban Process Calendar

Use Process Calendar Maintenance (17.1.13) to define the default calendar for a specific kanban process. Related programs are on the Kanban Setup Menu (17.1). Set up exceptions in Process Calendar Except Maint (17.1.14). You also can use Process Non-Workday Update to define full-day exceptions; see page 16.

**Fig. 2.5**  
Process Calendar Maintenance (17.1.13)

The screenshot shows a web application window titled "Process Calendar Maintenance". The window has a menu bar with "Go To", "Actions", "Copy", "Print", "Preview", and "Attach". Below the menu bar, there are two text input fields: "Site: 0630" and "Process: 0630p". Below these fields is a "Shift:" label with a dropdown menu showing "1". Below the shift dropdown is a table with the following data:

	Hours	Start Time	Productivity	Pattern
Sunday	0.00	00:00	100.00%	
Monday	0.00	00:00	100.00%	
Tuesday	6.00	00:00	100.00%	
Wednesday	6.00	00:00	100.00%	
Thursday	0.00	00:00	100.00%	
Friday	0.00	00:00	100.00%	
Saturday	0.00	00:00	100.00%	
Shift Total	12.00			
All Shifts	12.00			

**Site.** Enter the site that this calendar applies to. This is a required field.

**Process.** Enter the kanban process that this calendar applies to. It must be associated with the specified site. This is a required field.

**Note** Time fields are the same as described for Domain Calendar Maintenance. See page 9.

### Supplier Calendar

Use Supplier Calendar Maintenance (5.5.1.1) to define the default calendar for a specific supplier. Related programs are on the Supplier Schedules Setup Menu (5.5.1). Set up exceptions in Supplier Calendar Except Maint (5.5.1.4).

**Important** Unlike other calendar maintenance functions, this program includes additional navigation that lets you define holidays for the supplier. See “Non-Operating Days Frame” on page 14.

**Fig. 2.6**  
Supplier Calendar Maintenance (5.5.1.1)

	Hours	Start Time	Productivity	Pattern
Sunday	0.00	00:00	100.00%	
Monday	8.00	00:00	100.00%	
Tuesday	8.00	00:00	100.00%	
Wednesday	8.00	00:00	100.00%	
Thursday	8.00	00:00	100.00%	
Friday	8.00	00:00	100.00%	
Saturday	0.00	00:00	100.00%	
Shift Total	40.00			
All Shifts	40.00			

**Supplier.** Enter the supplier that this record applies to. This is a required field.

**Note** Time fields are the same as described for Domain Calendar Maintenance. See page 9.

#### Non-Operating Days Frame

Because your suppliers might observe different holidays than your own company, the system does not apply Holiday Maintenance records in calculations that use supplier calendars. Instead, it uses records defined in the Non-Operating Days frame of Supplier Calendar Maintenance.

**Note** This function can be used only for full days of non-operation. Use Supplier Calendar Exception Maint to define all other exceptions.

This frame is displayed after you save the basic calendar.

**Fig. 2.7**  
Supplier Calendar Maintenance, Non-Operating Days

Supplier: 00006105      00006105

Non-Operating Days

Date: 11/26/2015      Thursday

Description: U.S. HOLIDAY

**Date.** Specify the date of this non-operating day.

System calculations automatically adjust this supplier’s calendar to make this a non-working day for all defined shifts.

*Description.* Enter a description of this non-operating day; for example, Christmas Holiday.

## Setting Up Calendar Exceptions

If shift patterns vary because of overtime, increased or reduced shifts, or plant shutdowns, enter exception hours—that is, variations from the associated shop calendar. Set up exceptions for a date and shift by specifying the number of hours that are added to or subtracted from normal work hours.

You can apply calendar exceptions at any level of the calendar, from the domain down to the lowest level, using the associated menu function:

- Domain Calendar Exceptions Maint (36.2.4.4)
- Site Calendar Exceptions Maint (1.1.22.4)
- Production Line Cal Except Maint (18.1.22.3)
- Work Center Calendar Except Maint (14.18.4)
- Process Calendar Except Maint (17.1.14)
- Supplier Calendar Except Maint (5.5.1.4)

Additional .NET UI-only programs let you define full-day exceptions for certain calendar types. See “Setting Up Full-Day Exceptions” on page 16.

**Note** The system uses exception information only when preparing operation schedules, but not when calculating manufacturing order due dates.

To use the exceptions program, select an existing calendar using the same fields as the corresponding maintenance program. The following example shows Site Calendar Exceptions Maint.

**Note** You can only enter exceptions for a defined calendar. For example, if you enter a valid site that does not have a calendar defined, the system displays an error message.

**Fig. 2.8**  
Site Calendar Exceptions Maint (1.1.22.4)

Site:	0630
Date:	11/19/2015
Reference:	MAINT
Shift 1:	-2.00
Shift 2:	0.00
Shift 3:	0.00
Shift 4:	0.00

*Date.* Enter the date to have a calendar exception defined.

*Reference.* Enter a code representing the reason for the calendar exception. For example, you might enter OT to signify overtime.

*Shift 1 - 4.* Enter the number of hours (positive or negative) to be included in the calendar exception for each affected shift. If the exception does not apply to a shift, leave the value at zero.

If an exception occurs on a day that is not part of the standard work week, add that exception to an existing day rather than changing the standard work week. Many scheduling programs assume that the work week has a certain number of days. Adding a day to the standard work week can result in inaccurate schedules.

## Setting Up Full-Day Exceptions

You can set up full-day exceptions for one or more calendars associated with production lines, work centers, or kanban processes using the following .NET UI programs:

- Production Line Non-Workday Update
- Work Center Non-Workday Update
- Process Non-Workday Update

You do not enter a number of hours. The system uses the number of hours defined for the specified dates in the associated calendar maintenance program (adjusted for any exceptions), then assigns the equivalent negative value to that number. To enter partial days, you must use the appropriate exceptions maintenance program.

**Note** If there are multiple shifts, the update applies to all.

To create non-workdays:

- 1 Specify the site to be affected by the calendar updates. You can only specify a single site. This is a required field.
- 2 Enter program-specific information to select calendars for one or more production lines, work centers/machines, or processes.
- 3 Enter a range of dates to have the non-working exception applied. These are required fields.
- 4 Use the Update field to determine whether the function runs in simulation or update mode. When Update is No, the system displays a report so you can review the effects of the function before actually doing the update.
- 5 Use Reference to enter a code to identify the reason for the update. For example, you might add TRAIN to specify that the staff will be in training all day.
 

**Note** This field is optional when you run the program in simulation mode. However, when Update is Yes, you must specify a value in Reference.
- 6 Click Run. The system displays the results in the Viewer window.
- 7 If you ran the function in simulation mode, review the results, modify the selection criteria as needed until you get the required results, then run the function with Update set to Yes.

Fig. 2.9 Work Center Non-Workday Update

The screenshot shows the 'Work Center Non-Workday Update' application window. The search conditions are as follows:

- Site: equals 0001
- Work Center: equals 001
- Machine: equals
- Exception Date: range 12/28/2015 to 12/31/2015
- Update: equals No
- Reference: equals Holiday shutdown

The data table below shows the results of the search:

Site	Work Ctr	Machine	Date	Weekday	Reference	Daily Hours	Shift 1	Shift 2	Shift 3	Shift 4
0001	001		12/28/2015	Monday	Shutdown	-8.00	-8.00	0.00	0.00	0.00
0001	001		12/29/2015	Tuesday	Shutdown	-8.00	-8.00	0.00	0.00	0.00
0001	001		12/30/2015	Wednesday	Shutdown	-8.00	-8.00	0.00	0.00	0.00
0001	001		12/31/2015	Thursday	Shutdown	-8.00	-8.00	0.00	0.00	0.00

Page 1 / 1  
12/9/2015  
1:10:31 PM

### Defining Holidays

Use Holiday Maintenance (36.2.1) to schedule holidays and other nonwork days that apply to shop calendars for an entire site.

To apply holidays to the domain calendar, leave Site blank.

Holidays are days that no one works; the plant is shut down and no production is scheduled. Manufacturing orders are never due and operations are not scheduled on a holiday.

**Important** Your suppliers might not follow the same holiday schedule as your company, so the system does not use Holiday Maintenance records for suppliers. Instead, an additional frame in Supplier Calendar Maintenance lets you define full days for holidays. See “Non-Operating Days Frame” on page 14.

Fig. 2.10 Holiday Maintenance (36.2.1)

The screenshot shows the 'Holiday Maintenance' application window with the following input fields:

- Site: (blank)
- Date: 12/25/2015
- Friday
- Holiday: Christmas Day

## Using Generalized Codes

When you install a new QAD database, a number of system and reference fields accept any kind of data, as long as it does not exceed the field length. You can customize the user interface by adding generalized codes and lookups.

Before implementing a module or particular functional area, the implementation team should determine which fields should have generalized codes and lookups.

Generalized codes are domain specific since these codes may vary widely based on the type and location of the business operation. For example, customer types, sales distribution channels, and buyer/planner codes could differ between a domain representing a business in England and one in Germany.

**Important** Some programs that update system-wide data such as User Maintenance (36.3.1) reference generalized codes. These generalized codes must exist in all domains or you may encounter errors editing a user record depending on what your current working domain is.

When using generalized codes, you can control four different conditions:

- What the acceptable values in a field are. Define these values in Generalized Codes Maintenance (36.2.13).
- Whether a list of acceptable values displays in a lookup browse on the field. Specify this in Drill-Down/Lookup Maintenance (36.4.8.1).
- Whether the codes you have created are the only acceptable codes (that is, whether the list is validated). This may require you to add a validation expression to the data dictionary. See “Adding Validation” on page 20.
- Which users have permission to add, delete, and change generalized codes. If you decide to use generalized codes groups, you can set permissions to edit generalized codes at a more granular level. See “Generalized Codes Groups” on page 20.

### Field Validation

Before entering a list of generalized codes for a field, you must know the field’s name and size. In the character interface, the field name displays in a pop-up window when you press Ctrl+F with your cursor in the field. If the pop-up window indicates generalized codes validation, the system automatically verifies data entered in the field against the list of generalized codes.

You can also use Generalized Codes Validation Report (36.2.15) to view a list of all fields in the database that have schema validation assigned. This is the preferred method in the QAD .NET UI.

**Note** The system performs validation only when generalized codes have been defined for a field.

**Example** You have divided your customers into regions. The cm\_region in the customer master is updated in Customer Data Maintenance (2.1.1). As part of the implementation process, you assign each customer to one of two regions. To ensure that only standard region codes are used, define them as generalized codes. Specify cm\_region for the field name, the values US and X-US for the two regions.

## Adding Generalized Codes

Figure 2.11 illustrates Generalized Codes Maintenance (36.2.13).

**Fig. 2.11**  
Generalized Codes Maintenance (36.2.13)

*Field Name.* Specify a field name.

*Value.* Enter a valid value. Values cannot exceed the length of the field.

*Comments.* Enter a comment. The comment displays next to the value in the lookup.

*Group.* If you have permission, specify the generalized codes group that this generalized code belongs to. The group the field is currently assigned to is displayed in this field. This field is only relevant if you are using generalized codes groups.

## Adding a Lookup

To set up a lookup to display generalized codes, use Drill-Down/Lookup Maintenance (36.4.8.1). Enter the field name where you want the lookup and `gplu072.p` as the procedure to execute. See “Maintaining Drill Downs and Lookups” on page 56.

This program creates the lookup with values from the assigned field. If the lookup should only be accessed from a particular screen, enter that program name as the calling procedure.

**Fig. 2.12**  
Drill-Down/Lookup Maintenance (36.4.8.1)

The description defaults from the data dictionary, but can be changed here. If no description exists, the field name is a local variable. The description displays as the title of the lookup.

**Note** If you have not defined codes in Generalized Codes Maintenance for a field with generalized codes validation, a lookup icon is displayed next to the field in the QAD .NET UI. If you then define codes for the field, the lookup icon is changed to a drop-down list in which the new codes are selectable. This change is visible when you log out and back in to the system, or when you switch domains.

### Adding Validation

Generalized code validation, like field security, requires a special validation expression in the database dictionary that references the file `gpcode.v`.

Some fields already reference `gpcode.v`. These display in the Generalized Codes Validation Report. If you want to activate generalized code validation for other fields, you must change the data dictionary.

You can do this directly using full Progress or, if you have encrypted source, you can use the utility `utdbfx70.p`. Once you have added a validation expression, you must recompile the affected programs. For instructions on how to do this, refer to the *Progress Programming Handbook*.

To add validation for a local variable, you must insert the validation directly in the source code.

**Important** If you change the data dictionary, keep careful records and be prepared to repeat the change when new product versions that update the data dictionary are installed.

### Generalized Codes Groups

Using generalized codes groups, you can extend security access to Generalized Codes Maintenance beyond the system level down to the job functional level. This enables you to limit the generalized codes fields that a user can edit.

**Example** A buyer needs access to item generalized codes but does not need access to manufacturing codes.

By default, all generalized codes are assigned to one of two groups, SYSTEM or APP (Application). Generalized codes associated with system-supplied fields are assigned to the SYSTEM group. Generalized codes that are not part of the SYSTEM group are assigned to the APP group. Although the administrator can modify access for any role, all roles with Generalized Codes Maintenance access are automatically members of the APP group. Therefore, if you do not want to use generalized codes groups, no action is necessary and the system continues to function as expected.

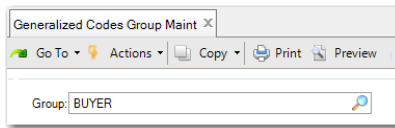
**Note** It is recommended that the system administrator enable administrator access to the SYSTEM group.

Before you use generalized codes groups, decide which groups you need, the fields to associate with each group, and which roles have access to each group. Next, follow these steps to establish generalized codes groups:

- 1 Create the groups in Generalized Codes Group Maint (36.2.10).

**Note** Enter a meaningful group name that contains a maximum of 24 characters.

**Fig. 2.13**  
Generalized Codes Group Maint (36.2.10)



- 2 If necessary, use Role Create (36.3.6.1) to create the roles you want to associate with these groups.
- 3 Ensure the role has access to Generalized Codes Maintenance under Secured items on menu in Role Permissions Maintain (36.3.6.5).
- 4 Associate roles with the generalized codes groups in Secured items not on menu under Generalized Code Groups.

**Note** If a role has access to all existing groups, the role is automatically assigned access to each new group. When the administrator removes access to any group for a given role, the administrator must manually grant access for each subsequent group added for that role.

- 5 Assign each field to its new group in Generalized Codes Maintenance (36.2.13).

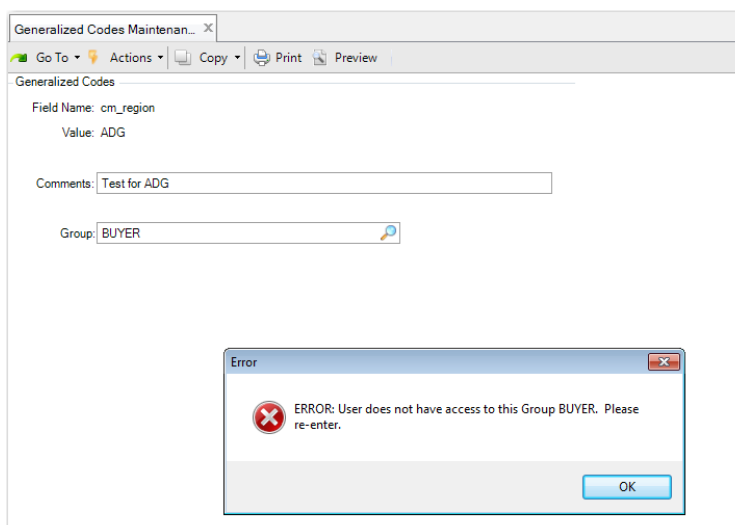
**Note** A field can only belong to one group.

### Working with Generalized Codes Groups

If you have implemented generalized codes groups in your system and associated the groups with specific roles, role members can assign a new code to any field belonging to a group they have access to. If a role member tries to assign a code to a field the role has no access to, an error message is displayed.

An administrator can move fields from one group to another in Generalized Codes Maintenance, provided the administrator has access to both groups. If a user with that role is not associated with a generalized codes group and attempts to add or modify a code associated with that group in Generalized Codes Maintenance, an error message is displayed.

**Fig. 2.14**  
Generalized Codes Maintenance (36.2.13)



If you want to delete a generalized codes group, you must make sure it is not associated with any generalized codes fields. If you try to delete a group tied to one or more fields, an error message is displayed. A generalized codes group associated with generalized codes can be synchronized to other domains and databases using QXtend. See *QAD QXtend User Guide*.

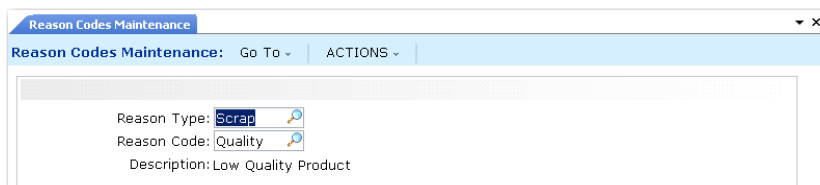
### Browsing Generalized Codes Group Security

All users can browse generalized codes group security to identify which generalized codes fields they have access to and to determine who has access if they do not. Based on a user search, the Generalized Codes Sec. Browse (36.2.11) displays generalized codes groups and the domain values for each group. The Role Resources Browse tab displays all roles that have permissions for a generalized codes group. The Generalized Codes Field Browse tab displays all fields that belong to a group.

## Using Reason Codes

Reason codes are used in security functions, sales quotes, sales order maintenance, purchase order returns, shop floor reporting, repetitive reporting, and the Product Change Control (PCC) module. They are also used if you have enabled change tracking and in several optional modules, such as WIP Lot Trace, Electronic Signatures, and Shipment Performance. Add other custom uses as needed.

**Fig. 2.15**  
Reason Codes Maintenance (36.2.17)



- Use codes of type User\_Act for the Active Reason field in User Maintenance (36.3.1) and the Auto-Deactivation Reason field in Security Control (36.3.24).
- Use codes of type ESIG to indicate why a user is authorizing the data in an e-signature enabled program.
- Use codes of type QUOTE in the Reason Lost field of sales quotations.
- Use codes of type CORRINV to specify why an invoice must be corrected in Sales Order Maintenance (7.1.1).
- Use codes of type DOWN or DOWNTIME in the Reason field of labor feedback programs (16.20.1 through 16.20.4).
- Use codes of type ORD\_CHG to associate changes made in Sales Order Maintenance to order detail, such as a change to the order line quantity or due date. See “Tracking Changes” on page 34.
- Use codes of type DOWN, DOWNTIME, REJECT, REWORK, ADJUST, and SCRAP for reporting in Repetitive and Advanced Repetitive programs. Use these same codes with the optional manufacturing WIP Lot Trace module.

- Use codes of type SCRAP with Advanced Repetitive subcontract shipping programs and Scrap Transaction Maintenance (3.14). For more information on subcontract shipping programs, see *QAD Sales User Guide*.
- Use codes of type SHIPQTY and SHIPTIME with the Shipment Performance module.
- Use codes of type RTV (return to vendor) to define reasons entered in Purchase Order Returns (5.13.7).

**Note** Codes used in the PCC module are user-defined. They specify severity levels related to approval of change documents.

## Managing Number Ranges

Some countries impose sequencing requirements related to tax filings or statutory reporting. In many countries, companies are legally required to prevent gaps in the numbering of official documents.

Additionally, certain business practices require different business units within the same corporation to maintain separate sequencing for similar documents such as purchase orders, sales orders, and supplier invoices.

**Example** In Italy, the number of an official document is strictly related to the date the document was printed, and it is a common practice to have multiple number ranges for shipment and invoice documents. In Brazil, the number of an official document is related to a specific physical site, requiring multiple number ranges with a prefix identifying a site code.

Number range management (NRM) supports varied sequencing requirements on a global scale. Features include gap control and multiple number ranges for the same document type.

### NRM Overview

NRM generates sequence numbers built from one or more segments, each with its own set of characteristics and behavior.

You can add or remove segments during sequence definition, but once a sequence has been used to generate or validate numbers, you cannot change its structure.

Figure 2.16 illustrates a sample sequence with five segments: three fixed-value segments (NY and two dashes), one incrementing integer segment (1234), and one date-driven segment (06:15:07).

**Fig. 2.16**  
Example Sequence Number

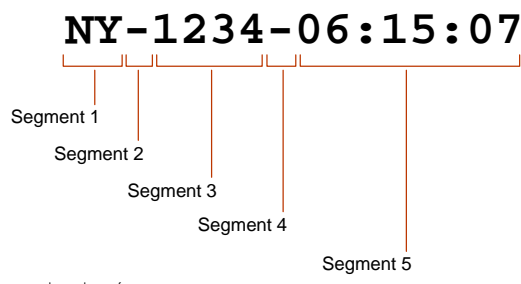


Table 2.1 describes the three segment types.

**Table 2.1**  
Number Segment Types

Segment Type	Description	Required
Incrementing Integer	A range of values, with a lower bound, an upper bound, initial, and reset value.	Yes. Each sequence number must have one and only one incrementing integer segment.
Date-Driven	A value that depends on the transaction effective date or the fiscal period that corresponds to the effective date.  The format is a compound string that allows the optional display of date components such as year, month, week, day, including delimiters between components.  Delimiters separate the individual components of a segment. For example, 06:15:07 uses colons as delimiters.	No. Each sequence can have one date-driven segment.
Fixed-Value	Any printable character except a comma. For example, NY may be a fixed-value segment assigned by a client in New York. A fixed-value segment is not changed in any way during sequence number generation.	No.

### Sequence Number Generation

To update a sequence number, the system examines each segment separately. Only date-driven or incrementing integer segment types are modified. A fixed-value segment is never changed.

### Control Segments

You can set up a date-driven segment as a control segment. In this case, changing its value causes the incrementing integer segment to reset to its assigned reset value. When a control segment does not exist or does not change, the incrementing integer segment is incremented.

### Sequence Parameters

Create sequence numbers and define sequence parameters using Number Range Maintenance (36.2.21.1). A distinct segment editor defines the format and parameters of each segment type.

### Internal and External Sequences

There are two types of sequence number: internal and external.

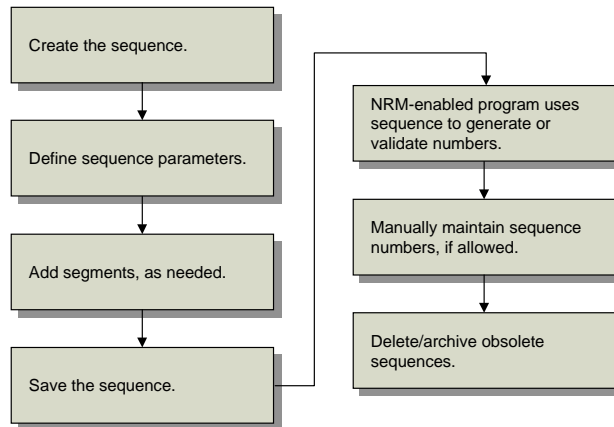
Internal sequences automatically generate numbers in ascending order as needed. NRM examines each segment in the sequence to determine whether to update its value. A fixed-value segment remains unchanged during sequence number generation.

External sequences accept a sequence number entered externally and validate it against a sequence definition. NRM verifies that the number belongs to the set defined by the sequence and that it has not yet been used. The system parses the number into segments and validates each segment against the corresponding segment in the sequence definition.

## Sequence Life Cycle

Figure 2.17 illustrates the life cycle of a sequence.

**Fig. 2.17**  
Sequence Life Cycle



To set up a sequence, create an ID, define general parameters, and add appropriate segments. Once a sequence is defined, a system program uses it either to obtain a new number or validate user-entered numbers. Programs must be specially designed to use NRM sequence numbers.

If you attempt to discard or void a number, the system checks the sequence definition to ensure that this is allowed.

You can delete and archive unneeded sequences.

## NRM Sequences

Programs must be specifically enabled to use NRM. Currently, NRM sequences are used in several system functions:

### Fixed Assets

An optional NRM sequence number can be specified in Fixed Asset Control (32.24) for automatically generating fixed asset ID numbers.

For more information on Fixed Asset Control, see [QAD Fixed Assets User Guide](#).

### General Ledger Daybooks

GL daybooks let you group and report GL transactions. Unposted transactions include the daybook code and daybook entry number. NRM generates entry numbers based on the ID of the daybook.

**Note** When the Daybook Control type is Operational, you can configure Number Range Maintenance for four customer invoice and credit note daybook types. See “Configuring a Customer Invoice Number Range” on page 30.

### Logistics Accounting

If you are using the optional Logistics Accounting module, two NRM sequences must be defined in Logistics Accounting Control (2.15.24) for distribution order shipments and sales order shipments.

For more information on Logistics Accounting, see [QAD Master Data User Guide](#).

In addition, if you use PO Shipper/Invoice Maintenance (5.13.14) to receive goods into a transit location, shipper/invoices use a unique NRM generated number.

### Shipping

Many countries legally require businesses to maintain strict control when assigning numbers to shipping documents. This is also true when multiple number ranges are assigned to the same type of shipping document. To meet this need, NRM is required for all shipper functionality.

For more information on shipping documents, see [QAD Sales User Guide](#).

### WIP Lot Trace

An optional NRM sequence number can be specified in WIP Lot Trace Control (3.22.13.24) for generating WIP lot and serial numbers in the various functions that trace them.

For more information on WIP Lot Trace Control, see [QAD Manufacturing User Guide](#).

### Kanban

If you use dispatch lists to communicate kanban card authorizations to your suppliers, you must specify an NRM sequence in Kanban Control (17.24). The system uses the sequence to generate an ID number during dispatch list processing.

For more information on Kanban Control, see [QAD Lean Manufacturing User Guide](#).

### Legal Documents

In some countries, the transportation of merchandise requires a document to prove legality and possession of the inventory being moved. Typically, the legal document includes such elements as the document number, ship-from address, ship-to address, item number and description, quantity, and so on.

When you assign a legal document sequence ID with a ship-from address or document format, the system uses that sequence to generate numbers for legal documents created during shipping transactions.

For more information on legal documents, see [QAD Sales User Guide](#).

**Note** The current release only supports issuing transactions. Receiving legal documents will be supported in a later release.

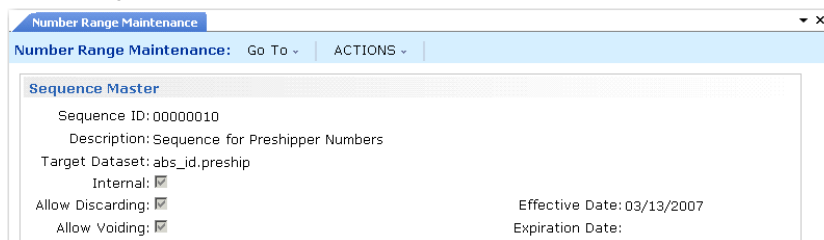
## Sales Order Numbers

You can set up optional NRM sequences to generate numbers for new orders entered in Sales Order Maintenance (7.1.1) and Pending Invoice Maintenance (7.13.1). See “Defining Sequences for Sales Orders” on page 33 for information.

## Setting Up Sequences

Create sequences and define sequence parameters using Number Range Maintenance (36.2.21.1). NRM uses a unique sequence ID to retrieve data and generate new numbers. Use Sequence Browse (36.2.21.2) to view the defined structure of a sequence.

**Fig. 2.18**  
Number Range Maintenance (36.2.21.1)



**Sequence ID.** Enter a code uniquely identifying a sequence. Create a new sequence or use Next/Previous to retrieve an existing sequence.

**Description.** Enter a description of this sequence, up to 40 characters.

**Target Dataset.** Enter the dataset identifier associated with this sequence. The target dataset can indicate who owns the sequence or where its numbers are used. A sequence owner can be a process, a document, or any other entity that the client program can recognize.

**Note** The target dataset could be the name of the principal database field where numbers from the sequence are used.

You cannot create a new sequence that intersects an existing sequence with the same target dataset—creating two sequences that could generate the same sequence number for the same target field.

For example, if sequences A and B both target field so\_nbr, they cannot have a common element that could cause conflicts.

The following three target datasets are used with shippers:

- abs\_id.shipper is used for sales order shippers.
- abs\_id.preship is used by sales order pre-shippers.
- abs\_id.mbol is used by master bills of lading.

For Fixed Assets, specify dataset fa\_id.

For Logistics Accounting, specify:

- la\_so\_ship\_id for sales order shipments
- la\_do\_ship\_id for distribution order shipments

For shipper/invoices, specify dataset abs\_id.poshipper.

For Kanban, specify dataset knbd.dispatch\_id.

For legal documents, specify dataset abs\_id.LegalDoc.

For sales orders, specify a dataset that begins with so\_nbr.

**Note** Additional language detail setup is required to use NRM to generate sales order numbers. See “Defining Sequences for Sales Orders” on page 33.

*Internal.* Specify whether the sequence numbers are supplied by an external source or automatically generated by NRM. Select the check box if numbers are generated by NRM.

*Allow Discarding.* Using a number causes it to be registered. This field determines whether a registered number can be discarded, leaving a gap in the sequence.

Clear (the default): Gaps are not allowed and numbers cannot be discarded from this sequence.

Selected: You can discard previously registered numbers from this sequence by reversing the register operation. NRM then erases all record of the sequence number, and the discarded number is replaced by a gap.

*Allow Voiding.* Determines whether you can mark a registered number as void.

Clear: Numbers in this sequence cannot be voided. This is the default.

Selected: You can void numbers and specify a brief description why. Voiding is recorded as a separate event in the sequence history.

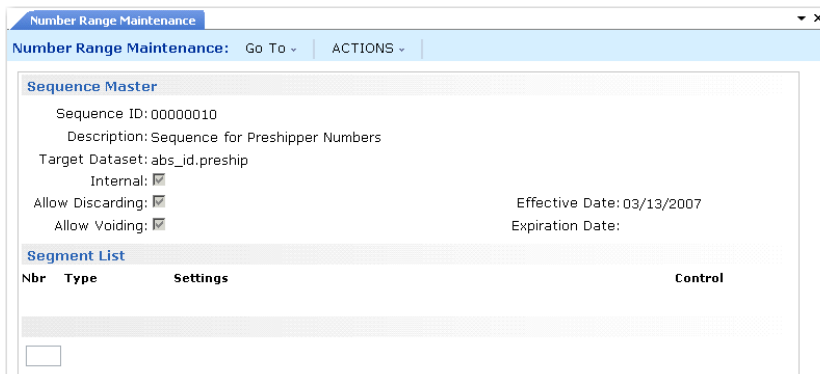
*Effective Date.* Indicates the earliest date when this sequence can be used.

*Expiration Date.* Indicates the latest date when this sequence can be used.

## Segment List

After you define the initial parameters for a sequence, Segment List and Editor frames display. The segment list shows the type and settings for each segment defined in the sequence. Segments display in ascending order, based on segment number.

**Fig. 2.19**  
Number Range Maintenance (36.2.21.1), Segment List Frame



## Segment Editors

The segment editor used depends on the type of segment being defined. Use the editor to create or modify the segment format definition and assign a new segment number. There are four types of segment editors.

- *Fixed* segment editor for fixed value segments
- *Integer* segment editor for incrementing integer segments
- *Date* segment editor for date-driven segments
- *Fiscal* segment editor for date-driven segments, relative to fiscal periods

### Fixed Segment Editor

Use the fixed segment editor to establish a fixed string value. You can use any printable character except a comma.

**Fig. 2.20**  
Fixed Segment Editor

### Integer Segment Editor

Use the integer segment editor to specify the initial, reset, minimum, and maximum values for a segment.

**Fig. 2.21**  
Integer Segment Editor

### Date Segment Editor

Use the date segment editor to tell NRM how to display a date component of a sequence number. Specify codes representing date components such as year, month, day. You can add components in any order, with optional delimiters. In the date segment 07/02, a forward slash is the delimiter. You can use any printable character except a comma or another date component as a delimiter.

You can indicate if this segment is a control segment. Changing the value of a control segment causes the incrementing integer segment to reset to its assigned reset value. The new value in the control segment ensures that the sequence numbers generated after resetting are unique within the target dataset.

**Fig. 2.22**  
Date Segment Editor

## Fiscal Segment Editor

Use the fiscal segment editor to tell NRM how to display a fiscal date component of a sequence number. You can add fiscal segments only if the sequence has an expiration date. Codes represent a component of a fiscal period. Otherwise, this editor is exactly the same as the date segment editor.

**Fig. 2.23**  
Fiscal Segment Editor

## Configuring a Customer Invoice Number Range

When the Daybook Control type is Operational, you can configure Number Range Maintenance for four customer invoice and credit note daybook types. They are:

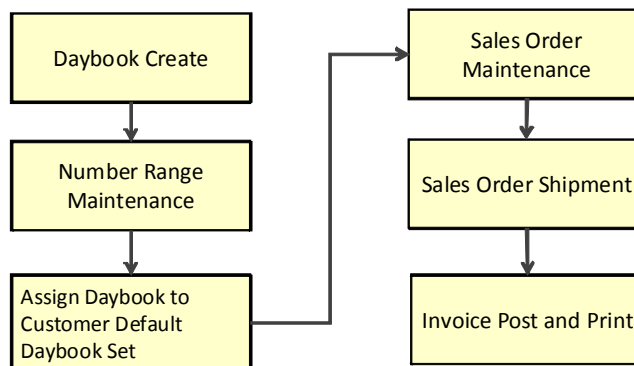
- Customer invoice
- Customer credit note
- Customer invoice correction
- Customer credit note corrections

This feature provides companies with the flexibility to configure the invoice number range format and the invoice number length. It also addresses business requirements for companies that want to configure their own customer invoice number range or want to reduce the length of the default customer invoice number range. In addition to specifying the invoice number length and format, you can specify whether the invoice numbering sequence must be continuous over subsequent GL calendar years or whether the sequence must restart each year.

**Important** For manually created Financial invoices, the numbering format is not configurable, uses the format year/daybook/voucher number, and is fixed at 22 digits.

The process to configure customer invoice number ranges includes several steps.

**Fig. 2.24**  
Configuring a Customer Invoice Number Range



- 1 Create a new daybook code in Daybook Create (25.8.1.1). Specify a daybook type of Customer Invoice and a daybook control of Operational.
- 2 Go to Number Range Maintenance to configure the number range for the daybook.

**Fig. 2.25**  
Number Range Maintenance

Number Range Maintenance

Go To Actions Copy Print Preview

Sequence Master

Sequence ID: AR-SEQ  
Description: AR Sequence  
Target Dataset  
Internal:   
Allow Discarding:  Effective Date: 01/09/2014  
Allow Voiding:  Expiration Date: 29/02/2016

Segment List

Nbr	Type	Settings	Control
1	FISCAL	Y2 (YYYY2)	yes
2	FIXED	ARINV	
3	INT	000001,999999,000001,000001	

Fiscal Segment Editor

New Seg Nbr:  Control Segment:   
Fiscal Format:

Delete Back Next

You must specify one FISCAL segment, at least one FIXED type segment, and one INT segment for the invoice number range:

- The FISCAL type segment denotes the GL calendar year. The default format for the Fiscal Format field is Y, which displays the year as four digits. If, for example, you want the year segment to only show two digits, update the fiscal format to Y2.
- A FIXED type segment for the daybook.
  - If you modify an existing customer invoice number range, the range may have a second FIXED segment containing “/”.
  - You can delete the FIXED segment of “/”, or add another FIXED segment, but you cannot delete the FIXED segment that contains the daybook code.
  - If you modify an existing number sequence, you can reduce the number of characters for the daybook code specified for the FIXED segment. For example, if the previous code was ARINV, you can change this to IV. However, the new FIXED segment code must be unique; that is, it must not be used for any other customer invoice number range.
- The INT (integer) type segment denotes the sequence number.

See “Customer Invoice Numbering Restrictions” on page 32 for specific restrictions that apply.

- 3 To ensure that new customer invoices follow this defined format, assign the daybook code to the default customer daybook set in Daybook Set Maintenance (25.8.7) or Daybook Set by Site Maintenance (25.8.10).
- 4 To use the new invoice numbering, create an order in Sales Order Maintenance (7.1.1).
- 5 Ship the order in Sales Order Shipments (7.9.15).

- 6 Run Invoice Post and Print (7.13.4) to create a new operational customer invoice. The new invoice number range format is applied.

Customer Invoice Numbering Restrictions

Customer invoice numbers are subject to validations in Number Range Maintenance. You cannot:

- Delete year, daybook, or sequence segments.
- Edit the expiry date.
- Modify segments of type INT during the GL calendar year.

However, you can:

- Modify the length of the segment.
- Change the segment order.
- Insert other segments of type FIXED.
- Delete a segment of type FIXED that initially contained the value “/”.
- Change the daybook code for a segment of type FIXED.

As with the number range sequences for Financial daybooks, clear the Allow Discarding and Allow Voiding fields in Number Range Maintenance for customer invoice number ranges.

For more information on customer invoices, see *QAD Financials User Guide*.

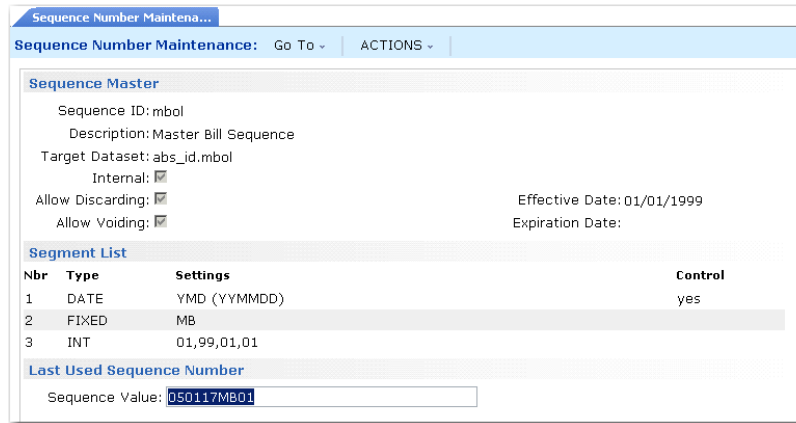
Setting Sequence Values

Use Sequence Number Maintenance (36.2.21.5) to set the next value for an existing sequence, when:

- The sequence is internal.
- Allow Discarding is selected.

The default in Sequence Value is the last number that was used. If you update it, the system validates the new value against the segment order and settings. It then increments the new value the next time the sequence is used.

Fig. 2.26 Sequence Number Maintenance (36.2.21.5)



## Defining Sequences for Sales Orders

You can define NRM sequences that assign numbers to sales orders in Sales Order Maintenance (7.1.1) and Pending Invoice Maintenance (7.13.1).

- 1 In Language Detail Maintenance (36.4.2), for Data Set `so_seq_id` and Field Name `seq_type`, create one or more mnemonics, assigned to Numeric Code 6 or higher.

**Note** Lower numbers are reserved for future functionality enhancements.

- 2 In Number Range Maintenance, create a new sequence ID and assign it to a dataset with the following value:

```
so_nbr.mnemonic
```

Where *mnemonic* comes from the language detail record defined in step 1.

You can define multiple sequences as needed if you want to assign order numbers based on site or some other criterion.

When any sequence definition is assigned to a dataset beginning with `so_nbr`, navigation changes in Sales Order Maintenance and Pending Invoice Maintenance during order entry. The system displays an additional Sequence ID field before assigning an order number. The look-up browse displays only IDs that have a dataset value beginning with `so_nbr`.

If you select a value, the system uses NRM to generate an order number based on the associated definition. If you leave Sequence ID blank, the system uses Sales Order Control (7.1.24) to determine the next order number.

## Viewing Sequence Number History

When a client program uses a sequence to dispense or validate numbers, the system creates history records. Use Sequence Number History Report (36.2.21.13) to view history data on internal and external sequences.

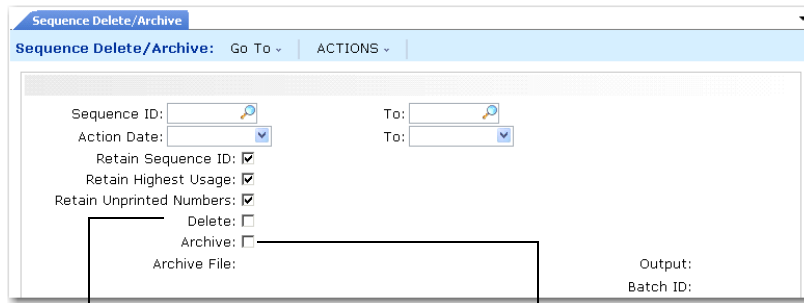
You can view the sequence definition, which sequence numbers have been used, and which sequence numbers have not been used, including gaps. This report helps you to identify missing documents by reporting numbers that are not recorded in the sequence history.

## Deleting and Archiving Sequences

Use Sequence Delete/Archive (36.2.21.23) to delete sequences and associated history. You can optionally archive information to an external file and later restore it using Archive File Reload (36.16.5).

Once sequence history is deleted, it no longer appears on the Sequence History Report.

**Fig. 2.27**  
Sequence Delete/Archive (36.2.21.23)



Specifies whether to delete historical information (selected) or review without deleting (deselected).

If selected, copies each selected record to the file displayed in Archive File.

## Tracking Changes

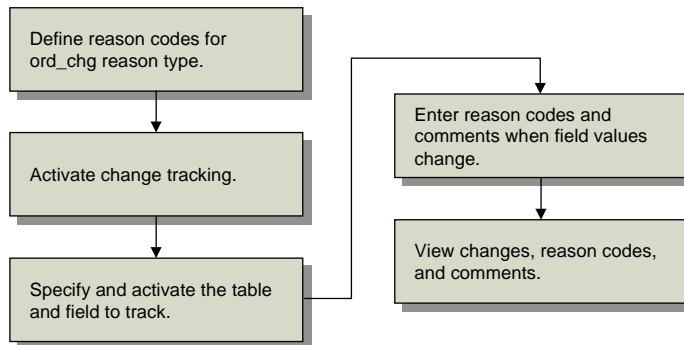
Use Change Tracking Maintenance (36.2.22) to mark sales order detail fields for change tracking. For line detail information in discrete sales orders, you can:

- Specify which field to track.
- Activate or deactivate tracking.
- Delete any records for fields that no longer require tracking.
- Allow users to enter a reason code and comments when the value of a marked field changes.
- Print the changes, reason codes that explain the changes, and any associated comments on a Booking Transaction Report (7.15.14). For more information on Booking Transaction Report, see *QAD Sales User Guide*.

## Change Tracking Implementation Overview

When implementing change tracking, you work with different programs to set up codes, activate change tracking, specify what to track, then view results. Figure 2.28 illustrates the basic change tracking implementation flow.

**Fig. 2.28**  
Change Tracking Implementation Flow



## Defining Change Tracking Reason Codes

You must define reason codes that explain changes to sales order detail in Reason Codes Maintenance (36.2.17). You specify `ord_chg` as the reason type. You must define at least one reason code for the `ord_chg` type to implement change tracking.

Create reason codes that fit your company's most common reasons for changes to sales order details. For example, you can create a Delete reason code for deleted orders. See "Using Reason Codes" on page 22.

## Activating Change Tracking

Activate change tracking by selecting Keep Booking History in Sales Order Control (7.1.24).

## Specifying Fields to Track

Use Change Tracking Maintenance (36.2.22) to:

- Specify which table contains the fields you want to track.
- Specify which fields to track.
- Delete any records for fields that no longer require tracking.

**Fig. 2.29**  
Change Tracking Maintenance (36.2.22)

The screenshot shows a web-based form titled "Change Tracking Maintenance". At the top, there is a header bar with "Change Tracking Maintenance: Go To" and "ACTIONS". Below this is a table with the following content:

Table	Description	Active	Delete
sod_det		<input checked="" type="checkbox"/>	<input type="checkbox"/>

Below the table, there is a section for adding a new field to track:

Field:   
 Description:   
 Active:

**Table.** Enter the database table that contains the field that is being tracked for changes. Currently, Change Tracking Maintenance tracks only the sales order detail (`sod_det`) table.

**Description.** Enter a brief description (24 characters) of the database table.

**Active.** Select to track changes for the database table you specified. Clear to deactivate tracking. The default is clear.

You must select Active for both the table and the field before change tracking begins.

**Delete.** Select to display the reason code pop-up in Sales Order Maintenance when the user deletes an entire sales order line. Clear if you do not want the reason code pop-up to display. The default is clear.

**Note** You must select Active and specify a field to track.

Once you complete these fields and click Next, the following frame appears.

**Fig. 2.30**  
Change Tracking Maintenance, Field Frame

', and 'Delete: '. Below this, there is a 'Field:' input field, a 'Description:' label, and an 'Active: 

**Field.** Enter the field to track. Currently, you can only track fields belonging to the sales order detail (sod\_det) table.

**Note** To find the field name in the character interface, press Ctrl+F while your cursor is located in the field. In the QAD .NET UI, the field name displays as a field tip when your cursor moves over a field.

**Description.** Enter a brief description (24 characters) of the field.

**Active.** Select to activate tracking for the field you specified. Deselect to deactivate tracking (the default).

Review the tables and fields you specify and their active or delete status using Change Tracking Browse (36.2.23).

### Reason Code Pop-Up

After you activate change tracking and specify a table and field to track, when the user changes or deletes the value of the field, a reason code pop-up displays. Currently, only the sales order detail table can be tracked; therefore, the reason code pop-up displays in Sales Order Maintenance (7.1.1).

Select a code that indicates the reason you are changing the value of the field or deleting the line. The reason type associated with the code must be ord\_chg.

Even though you can track multiple fields, you are only prompted once with the reason code pop-up. Use the comment screen to explain multiple changes you made to the sales order line.

### Viewing Changes

To view changes you tracked, use Booking Transaction Report (7.15.14). The report displays the reason and comments related to a discrete sales order line change.

To display the changes:

- Set Summary/Detail to Detail.
- Select Include Reason/Comments.

Fig. 2.31  
Booking Transaction Report (7.15.14)

The screenshot shows a web application window titled "Booking Transaction Report". The window has a header bar with "Booking Transaction Report:" on the left, "Go To" with a dropdown arrow, and "ACTIONS" with a dropdown arrow. Below the header is a search area with the following fields and options:

- Item Number: [Text Input]
- Product Line: [Text Input]
- Effective: [Dropdown Menu]
- Address: [Text Input]
- Sales/Job: [Text Input]
- Region: [Text Input]
- Site: [Text Input]
- To: [Text Input]
- To: [Text Input]
- To: [Text Input]
- To: [Text Input]
- To: [Text Input]
- To: [Text Input]

Below the search fields are several checkboxes and a dropdown menu:

- Show Revision Detail:
- Summary/Detail: [Dropdown Menu, currently set to "Detail"]
- Currency: [Text Input]
- Include Reason/Comments:

At the bottom right of the search area, there are two labels:

- Output:
- Batch ID:



# System Interface

The System Interface menu contains programs that control menus, messages, multi-language installations, browses, and help.

Languages, menus, messages, user functions, help, labels, and e-mail definitions are all system-wide data and apply to all domains in a database.

## ***Overview of User Interface*** 41

Describes the system interface menu.

## ***Using Multiple Languages*** 45

Discusses how to use multiple languages and Unicode, set up multiple languages, Language Detail Maintenance, and report translation.

## ***Customizing Menu Information*** 49

Explains how to customize menu information by executing menu items, and describes the menu structure, menus and security, Menu System Maintenance. Also discusses how to set up menu substitutions, define program information, and view business components.

## ***Modifying Messages*** 55

Explains how to use Message Maintenance.

## ***Creating and Managing Browses*** 56

Explains how to maintain drill downs and lookups, create access to other programs, manage stored searches, define browse URL links, create browses, and create views.

## ***Defining User Menu and Function Keys*** 73

Explains how to use the user menu, execute programs in sequence, and use User Function Maintenance.

## ***Using Field and Program Help*** 74

Explains how to add user help and print help documents.

## ***Setting User Telnet Options*** 75

Explains how to configure telnet server settings, define the login sequence script lines, configure telnet connection settings, and verify the login sequence.

## ***Modifying Labels*** 79

Explains how to use Label Master Maintenance.

***Building an E-Mail System Interface 80***

Explains how to set up e-mail system inquiries, use text e-mail, e-mail attachments, use E-mail Definition Maintenance, modify e-mail command parameters, customize the appearance of HTML e-mail, and configure e-mail notification for components.

***Using Advanced Reporting Tools 83***

Explains how to use the Report Setup Menu, QAD-provided dashboards, and custom reports and dashboards.

***Monitoring User Sessions 84***

Explains how to use Session Master Maintenance.

## Overview of User Interface

QAD application functions can be used in two ways:

- All functions are available in a .NET-based graphical user interface (UI).
- A subset of functions can be used in a simplified character interface.

For programs that run in the .NET UI, some present simple HTML screens; other use an advanced component-based technology that supports tabbed navigation and other technologies that are not available with standard programs.

The functions on the System Interfaces menu let you manage different aspects of information that display on the UI and that affect how users interact with the system. Some of these functions apply only to the character UI, some to .NET UI, some to component-based functions, and some to all functions.

Table 3.1 lists all the menu items on the System Interface Menu. The Program column indicates if this is a standard Progress program (.p) or a component with activities. The UI column indicates which user interface the program can be run from. Some programs—such as the component activities—can only be opened in the .NET UI; others can be used in both character and the .NET UI. The column labeled Affects indicates which programs the System Interface program affects:

- All programs, including standard Progress programs in the character UI, Progress programs running as HTML screens in .NET UI, and component-based functions in the .NET UI
- Standard programs in both character and .NET UI
- Standard programs in character only
- Standard programs in .NET UI only
- Component-based activities in .NET UI only

**Note** While it may be possible to execute a program from both the .NET UI and the character UI, the effect of the program may be seen in only one UI. For example, you can set up menu URLs from the character UI or the .NET UI, but the links are only active in browses run from the .NET; they cannot be executed from character browses.

**Table 3.1**  
System Interface Menu

Menu No.	Menu Description	Program	UI	Affects
36.4.1	Language Maintenance	Component	.NET	All programs
36.4.1.1	Language Create	Activity		
36.4.1.2	Language Modify	Activity		
36.4.1.3	Language View	Activity		
36.4.1.3	Language Delete	Activity		
36.4.2	Language Detail Maintenance	mglngumt.p	Both	Standard programs in either UI

Table 3.1 — *System Interface Menu* — (Page 1 of 4)

Menu No.	Menu Description	Program	UI	Affects
36.4.3	Report Translation Maintenance	Component	.NET	Component-based reports
36.4.3.1	Report Translation Create	Activity		
36.4.3.2	Report Translation Modify	Activity		
36.4.3.3	Report Translation View	Activity		
36.4.3.4	Report Translation Delete	Activity		
<b>36.4.4</b>	<b>Menu System Menu</b>			
36.4.4.1	Menu System Maintenance	mgmemt.p	Both	All programs
36.4.4.2	Menu System Report	mgmerp.p	Both	All programs
36.4.4.7	Menu Substitution Maintenance	mgmsmt.p	Both	Standard programs in character UI
36.4.4.8	Menu Substitution Browse	mgbr013.p	Both	Standard programs in character UI
36.4.4.13	Program Information Maintenance	mgpgmimt.p	Both	Standard programs in either UI
36.4.4.14	Program Information Browse	mgbr060.p	Both	Standard programs in either UI
36.4.4.15	Program Information Update	mgpgmiut.p	Both	Standard programs in either UI
36.4.4.22	Business Component View	Activity	.NET	View only
<b>36.4.6</b>	<b>Message Menu</b>			
36.4.6.1	Message Maintenance	mgmsgmt.p	Both	Standard programs in either UI
36.4.6.2	Message Browse	mgbr006.p	Both	Standard programs in either UI
36.4.6.3	Message Report	mgmsgrp.p	Both	Standard programs in either UI
36.4.6.13	Configured Message Maintenance	mgcfmmt.p	Both	Standard programs in either UI
36.4.6.14	Config Msg Verif Report	rgrp14.p	Both	Standard programs in either UI
36.4.8	Browse Menu			
36.4.8.1	Drill-Down/Lookup Maintenance	mgdlfhmt.p	Both	Standard programs in either UI
36.4.8.2	Drill-Down Browse	mgbr001.p	Both	Standard programs in either UI
36.4.8.3	Lookup Browse	mgbr005.p	Both	Standard programs in either UI
36.4.8.5	User Tool Maintenance	mgtoolmt.p	Both	Standard programs in .NET UI only
Table 3.1 — System Interface Menu — (Page 2 of 4)				

Menu No.	Menu Description	Program	UI	Affects
36.4.8.7	Stored Search Maintenance	Component	.NET	Component-based browses in .NET UI
36.4.8.7.1	Stored Search View	Activity		
36.4.8.7.2	Stored Search Export Browse Defaults	Activity		
36.4.8.7.3	Stored Search Delete	Activity		
36.4.8.9	Browse URL Maintenance	mgburlmt.p	Both	Standard browses in .NET UI
36.4.8.10	Browse URL Browse	mgbr221.p	Both	Standard browses in .NET UI
36.4.8.13	Browse Maintenance	mgbwmt.p	Both	Standard programs in either UI
36.4.8.14	Browse Master Browse	mgbr003.p	Both	Standard programs in either UI
36.4.8.15	Browse Detail by Field	mgbr040.p	Both	Standard programs in either UI
36.4.8.18	View Maintenance	mgvwmt.p	Both	Standard programs in either UI
36.4.8.19	View Browse	mgbr020.p	Both	Standard programs in either UI
36.4.10	User Function Maintenance	mgufmt.p	Both	Standard programs in character UI
36.4.11	User Function Browse	mgbr008.p	Both	Standard programs in character UI
36.4.12	User-Defined Field Maintenance			
36.4.12.1	User-Defined Field Create	Activity	.NET	Component-based activities. Chapter 12, "UI Customization," on page 249.
36.4.12.2	User-Defined Field Modify	Activity		
36.4.12.3	User-Defined Field View	Activity		
36.4.12.4	User-Defined Field Delete	Activity		
<b>36.4.13</b>	<b>Field Help Menu</b>			
36.4.13.1	Field Help Maintenance	mgflhusr.p	Both	Standard programs in either UI
36.4.13.2	Field Help Report	mgflhdrp.p	Both	Standard programs in either UI
36.4.13.3	Field Help Book Report	mgflbook.p	Both	Standard programs in either UI
36.4.13.4	Procedure Help Report	mgflprrp.p	Both	Standard programs in either UI
36.4.13.13	Field Help Dump	mgfldmp.p	Both	Standard programs in either UI
36.4.13.14	Field Help Load	mgflld.p	Both	Standard programs in either UI
Table 3.1 — <i>System Interface Menu</i> — (Page 3 of 4)				

Menu No.	Menu Description	Program	UI	Affects
36.4.14	User Option Telnet Maintenance	mgusrmt.p	Both	Standard programs in .NET UI
36.4.15	User Option Report	mgusrrp.p	Both	Standard programs in .NET UI
<b>36.4.17</b>	<b>Label Menu</b>			
36.4.17.1	Label Master Maintenance	gplblmt.p	Both	Standard programs in either UI
36.4.17.2	Label Master Browse	gpbr405.p	Both	Standard programs in either UI
36.4.17.5	Label Detail Maintenance	gplbldmt.p	Both	Standard programs in either UI
36.4.17.6	Label Detail Browse by Field	gpbr406.p	Both	Standard programs in either UI
36.4.17.7	Label Detail Browse by Program	gpbr407.p	Both	Standard programs in either UI
36.4.17.24	Label Control	gplblpm.p	Both	Standard programs in either UI
36.4.18	Customization Export	Activity	.NET	Component-based functions in .NET
36.4.19	Customization Delete	Activity	.NET	Component-based functions in .NET
36.4.20	E-mail Definition Maintenance	mgemmt.p	Both	Standard programs in either UI
<b>36.4.21</b>	<b>Report Setup Menu</b>			
36.4.21.1	Report Maintenance	rprprmt.p	Both	Standard programs in either UI
36.4.21.2	Report Synchronization	rprpsync.p	Both	Standard programs in either UI
36.4.21.3	Report Parameter Maintenance	rprpmt.p	Both	Standard programs in either UI
36.4.21.4	Report Parameter Synchronization	rpptsync.p	Both	Standard programs in either UI
36.4.21.13	Admin User Variant Maintenance	rpuvmt01.p	Both	Standard programs in either UI
36.4.21.14	Personal User Variant Maintenance	rpuvmt02.p	Both	Standard programs in either UI
36.4.21.21	Report Resource Import	rprroim.p	Both	Standard programs in either UI
36.4.21.22	Report Resource Export	rprroex.p	Both	Standard programs in either UI
36.4.21.24	Report Control	rppm.p	Both	Standard programs in either UI
36.4.22	Session Master Maintenance	mgsessmt.p	Both	All programs
Table 3.1 — System Interface Menu — (Page 4 of 4)				

## Using Multiple Languages

A single QAD database can be set up with multiple domains, each with a distinct language. With a Unicode database, languages with different code pages can be supported in the same database. Defining a Unicode database is an installation option described in the relevant installation guide for your system.

Unicode is a data storage and display protocol—essentially a combination of a code page and collation table. The QAD Unicode database uses the UTF-8 code page, which includes all characters from all languages; the collation table sets the sort order for those characters for display or reporting. The advantage of Unicode is that one database can contain as many languages as you require. Without Unicode, a single database can include only languages that share the same code page—such as French, German, and Spanish—or languages with compatible code pages—such as English and Chinese.

Each user is also assigned a language. A user logging in through the .NET UI can access any domain in a Unicode database regardless of their associated language. The character client, however, does not support Unicode. A user logging in through the character UI must log in to a domain with a code page that is compatible with the language they are assigned, as defined in Domain Create (36.1.1.1.1). For more information on domains, see [QAD Financials User Guide](#).

**Example** A database includes three domains: French, Chinese, and English. John is assigned the Chinese language. John can log in to all three domains in the .NET UI. When using the character UI, John cannot log in to the French domain; an error displays if he tries to do this.

Multi-language capabilities are used in two areas:

- Screens and screen elements such as labels and messages are displayed in multiple languages.
- Data is stored and displayed in multiple languages.

All single set of r-code can be used with all supported languages. Language-specific data is loaded during installation. Based on the language associated with the user, screen labels, menus, messages, and field help is displayed in the appropriate language.

Labels, menus, and messages are stored in the production database. Field help is in the field help database, `mfgHELP.db`. To retrieve data in multiple languages, each of these types of information is stored once in each language.

Most orders include comments, which often must be in multiple languages. These can be stored in multiple languages and retrieved by language ID. You can also customize menus and messages and assign a language ID so the system knows which entry to display.

Standard programs support only a limited amount of data that is stored and displayed by language ID. This data is defined in Language Detail Maintenance (36.4.2). However, component-based functions provide extended translation features. You can provide your own language translations for descriptions of shared data such as accounts, sub-accounts, and cost centers. For more information on the Translation Option, see [Introduction to QAD Enterprise Applications User Guide](#).

You can also provide translations for custom labels assigned to component-based reports.

## Multiple Languages and Unicode

.NET UI clients are fully Unicode compliant; a user logged in through the .NET UI can access any domain, regardless of its defined code page.

Character clients do not support Unicode and must log in to a domain with a compatible code page, as defined in Domain Create. This is to prevent the possibility of data corruption when characters cannot be interpreted correctly. Once logged in through the character UI, users are limited in which domains that they can switch to.

However, some domain switching can happen behind the scenes when processes such as Distribution Requirements Planning (DRP) are being used. In a Unicode database, these processes should be run from batch to prevent code page issues.

If your implementation includes a Unicode database and you have some users executing functions from character clients, you should be aware of the following restrictions.

### Creating Sites

When you create a site in one domain, connection records for that site are optionally created in other domains in the database. This is to support cross-domain features such as Distributed Requirements Planning (DRP).

If any of the domains in the database have incompatible code pages, creating site connection records is not possible from the character UI. If you need to create these records, you must use Site Maintenance (1.1.13) from the .NET UI.

### Running Batch Jobs

If you routinely run batch jobs across multiple domains in a Unicode database, you should set up scripts with the correct Unicode startup parameters to avoid code page issues. See “Invoke Batch Processing from CIM” on page 98.

### Running DRP and MRP

DRP is one of the areas where the system may need to change to a different domain based on the sourcing relationships for items that you have set up. If you have set up relationships between sites in domains that have incompatible code pages, this switching cannot be done when DRP is run from a character client. This is true of stand-alone DRP using programs on 12.13, or running Materials Requirements Planning (MRP) when the DRP/MRP Combined field is selected in DRP Control (12.13.24).

If the system detects that the domains are incompatible, an error is generated and DRP will not complete its execution.

To avoid errors, run DRP or MRP in batch mode with a Unicode database; for example, use the following parameters with your Progress batch command to use the UTF-8 code page:

```
-cpinternal utf-8 -cpstream utf-8
```

For details on setting up the batch job, see “Invoke Batch Processing from CIM” on page 98.

## Setting Up Multiple Languages

A base set of language codes is supplied with the system. System-defined languages cannot be changed or deleted.

Use the Language Maintenance activities (36.4.1) to view all records, create new ones, modify user-defined records, or delete user-defined records. For more information on language activities, see *QAD Financials User Guide*.

To implement multiple languages in a database, you must:

- 1 Load the appropriate language data, either during initial system implementation or later. Loading translated labels marks the language as installed so that it is available to be associated with users.
- 2 Create countries for users in Country Create (36.1.3.1.1). Each country to be associated with a user must have an ISO country code specified in the Alternate Code field in Country Code Data Maintenance (2.14.1). Regional display defaults are determined by the ISO country, such as date and number formats.
- 3 Designate the default language and country code for each user in User Maintenance (36.3.1). This ensures that when the user logs on, the system displays data in that person's language with the correct regional formatting. For more information on User Maintenance, see *QAD Security and Controls User Guide*.

If the language is the same for all users but multiple language comments are required for orders, you only need to define the separate language codes using the Language function. A number of codes for supported languages are already defined.

## Language Detail Maintenance

Some program options appear on the screen using alphabetic codes or words. Internally, these options are controlled by numeric codes. Mnemonics and labels provided in English are not always appropriate in other languages. Use Language Detail Maintenance (36.4.2) to change, add, and delete mnemonic codes and labels.

**Fig. 3.1**  
Language Detail Maintenance (36.4.2)

The screenshot shows a window titled "Language Detail Maintenance" with a menu bar containing "Go To" and "ACTIONS". The main content area displays the following information:

```

Language ID: us      english (U.S.)
Data Set: ac_mstr
Field Name: book_type
Numeric Code: 1
Translatable Text:
Mnemonic: L
Label: Legal
  
```

**Data Set.** Enter the program name, a database table name, or an abbreviation of the functionality for a field.

**Field.** Enter the field name associated with the data set.

**Numeric Codes.** These are the values used by the programs. A mnemonic code can be assigned for each numeric code. Codes cannot be added or edited.

**Mnemonic.** Mnemonic codes are already assigned for each field with several system-specified options. These codes can be changed, added, or deleted using this program.

**Label.** Default labels already exist for the different mnemonic codes. These labels can be changed, added, or deleted using this program.

## Report Translation

The Report Translation activities (36.4.3) let you create, view, modify, and delete custom labels used in component-based reporting functions.

Using these activities, you can modify the standard QAD translations or create new translations. Labels are grouped by business component and, then, by report. The labels that are common to all reports of a business component are stored with a blank report name. The labels that are specific to one report reference the report name.

The report labels are stored in the database and are retrieved at run-time (report execution) in the correct language and sent to the Crystal reports viewer. This viewer receives the report data and labels from the application and formats them according to the layout in the .rpt file.

For standard QAD labels, the QAD Standard check box is selected and the Report Translation Code cannot be changed.

If you want to add a new label to a component and make it available to all reports for that component, ensure that the label is defined in the .rpt file with the correct Report Translation Code.

**Fig. 3.2**  
Report Translation Create (36.4.3)

**Report Translation Code.** Specify the Report Translation Code to use on reports and to which the translation is linked.

**Business Component.** Specify the business component to which the report belongs.

**Report Name.** Specify the report to which the translation applies.

**QAD Standard.** Select to indicate if the translation is a standard QAD translation.

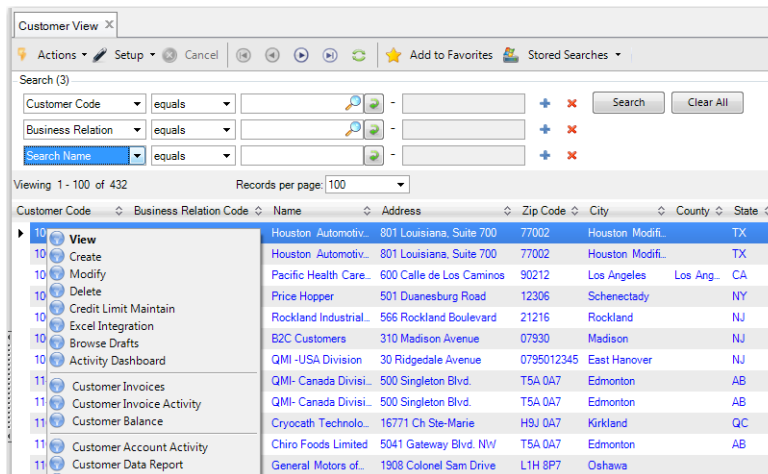
**Text.** Type the translated text.

## Customizing Menu Information

Menus are loaded as part of initial system implementation. Both standard Progress programs and component-based functions are set up in the menu system.

- A standard Progress program is generally accessed from the menu, although you can add links from one program to another. See “Creating Access to Other Programs” on page 59 for details on linking programs.
- Activities associated with components can be selected from the menu; they can also be accessed from a right-click menu in the component view; see Figure 3.3.

**Fig. 3.3**  
Right-Click Menu in Component View



## Executing Menu Items

From the .NET UI, you can execute standard programs and component activities in these ways:

- Type enough of the menu number or menu label in the search box to uniquely identify the program and press Enter.
- For standard programs only, type the program name, such as `mgmment . p`, in the Search box and press Enter.
- Double-click the menu item in the menu listing.
- Choose a program or activity from the Go To menu from in an open program screen.

In the character UI, you can execute only standard programs and only in these ways:

- Type the program name, such as `mgmment . p`, or number, such as `36.4.4.1`, at any menu prompt.

**Note** If you are currently on another branch of the menu tree (for example the 1.4 menu), enter a period before the menu number (`.36.4.4.1`). Type a partial number from a submenu, such as `4.4` while located at menu `36`.

- Press a function key that is assigned to this program or select the program from the User Menu. See “Defining User Menu and Function Keys” on page 73 for details.

## Menu Structure

The menu system controls what displays when a user logs in. It is designed like a product structure, recorded as single-level relationships between a parent menu item and a child item. At the top level in the character UI, the parent item is the Main Menu (Menu 0).

**Note** The menu groups represented by the folders in the .NET UI are referenced through the letter A. For example A.1 is Sales, A.2 is Manufacturing and so on.

At lower levels, the parent item is a submenu such as the Call Management Menu (11.1) or an executable function.

Menus are stored in a table indexed by language ID. Each user has a default language. When a user logs on, the system determines the user language and displays menu text in that language.

As a user moves through menus and makes selections, the Execution File specified in Menu System Maintenance controls the function or submenu that displays. Selecting 2. Addresses from the Main Menu sets the Execution File to 2, telling the system to access Menu 2. Selecting 12 from Menu 2 sets the Execution File to admgmt06.p, telling the system to run Company Address Maintenance.

QAD applications are delivered with all offered menus and functions. You can remove menus for programs that you do not use by either taking them off the menu or controlling them with menu security.

**Note** It is easier to update your software releases if menus are not modified. Instead, use menu security for functions you do not use. In the character UI, you can set up User Menus for commonly used menus and functions. In the .NET UI, each user can use the Favorites feature to define a personal menu subsystem of commonly used functions.

## Menus and Security

Users can only see functions they have been given access to, based on their role membership. Menu items are assigned to roles in Role Permissions Maintain (36.3.6.5). Each user is assigned to one or more roles in Role Membership Maintain (36.3.6.6) in the context of specific domains and entities.

When a user logs in, the system builds the menu for that user based on the login domain and entity (workspace in the .NET UI) and the set of roles assigned to the user. The menus represent the combination of all functions the user has access to in that domain and entity.

**Note** When logging in through the character UI, a user must have access to the primary entity of the selected domain; in the .NET UI, the workspace represents any valid domain/entity combination for which the user has been granted access.

When you add an item to the menu, access must be explicitly granted before anyone can see that menu item and run the function, including yourself. You must use Role Permissions Maintain to add the menu item to the appropriate roles.

**Note** Users cannot run any program that is not on the menu. If you want users to be able to run custom programs or utilities from an application session, you must add the program to the menu and give the appropriate user roles access to it.

For more information on roles, see [QAD Security and Controls User Guide](#).

## Menu System Maintenance

Use Menu System Maintenance (36.4.4.1) to assign menu labels and execution files to menu numbers.

In the QAD .NET UI, the interface to Menu System Maintenance has been enhanced to make it easier to use. For more information on Menu System Maintenance, see [QAD .NET UI Administration Guide](#).

You can control the menu numbers and the names associated with programs in several ways.

- Move menu items.
- Change menu names.
- Create shortcut names for menu items.

**Note** If you make these changes, they may be lost during software updates when menus are reloaded.

**Important** Menus are cached in memory when you log in to the system. You must log out and log in again to see any changes made with this program. In addition, if you add menu items, you must grant access to them before anyone can see them. See the previous section on menus and security.

**Fig. 3.4**  
Menu System Maintenance (36.4.4.1)

The Name field lets you call programs using keywords. For a program buried deep in the menu structure, you can add a name and then execute the program by typing that name on any menu command line.

**Example** Many of your users create sales orders. Enter SO in the Name field for 7.1.1. Users can then type SO at the menu prompt or Search box and Sales Order Maintenance (7.1.1) displays.

The execution procedure can be:

- A menu number such as 1.1
- A Progress program such as `sosomt.p`
- A component-based activity specified in the form of a uniform resource name (URN) such as `urn:cbf:BCreditor.Modify`
- A process map specified in the form of an URN such as `urn:pmap:IndustryProcessLevel1`
- A browse collection specified in the form of an URN such as `urn:collection:fc4af10-e778-4db5-9461-766f5b7e2891`

## Setting Up Menu Substitutions

Use Menu Substitution Maintenance (36.4.4.7) to set up a link between two standard programs so that when users select one from a menu, the other program displays. This is useful for substituting custom versions of existing programs.

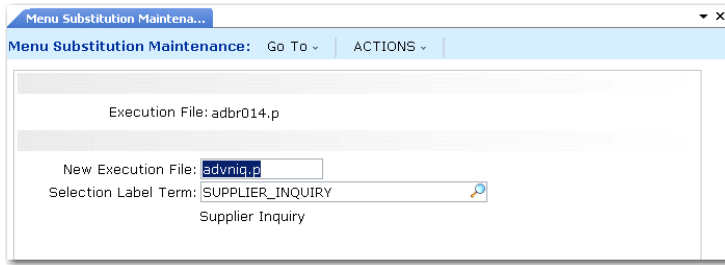
Menu substitution affects standard programs in the character UI in these ways:

- Replaces browses with inquiry programs
- Replaces standard programs with custom versions

**Note** This program applies to standard Progress programs in the character environment only; you cannot use it with component-based functions and it does not affect the menu in the .NET UI. In the .NET UI, standard programs and browses always display.

In the character interface, which program is invoked for a particular user depends on whether menu substitution is enabled in the user record in User Maintenance (36.3.1).

**Fig. 3.5**  
Menu Substitution Maintenance (36.4.4.7)



- 1 Enter the program name in Execution File. Users selecting this program from a menu will actually be running the one entered into the New Execution File field.
- 2 Enter the substitute program name in New Execution File. This is the name of the program to replace the one entered in Execution File. Users will run this program when they select the one entered in the Execution File field. You can use wildcards. For example, if you want to replace all inquiry programs with the browse versions, you enter `*iq*` in the Execution File field and `*br*` here.
- 3 Enter a label term in Selection Label Term. The long label contained in this term appears in the title bar and menu list of the substituted program.

## Defining Program Information

The program information table contains a record for each standard menu-level program, defining characteristics that affect the way it runs. Each standard program in the .NET UI must have a record both in Menu System Maintenance and in Program Information Maintenance (36.3.21.1).

**Note** Component activities are defined in Menu System Maintenance, but not in Program Information Maintenance.

In addition to menu-level programs, lookups must be defined in order for the lookup icon to display next to a field in an HTML screen.

Program information records are loaded with other default data during system installation and can be viewed in Program Information Maintenance or Program Information Browse (36.4.4.14). You must manually create records for any custom programs that you want users to be able to access as HTML programs from the .NET UI. Otherwise, they will open in Terminal mode.

**Note** Terminal mode lets you run programs with a character-mode UI, using a telnet session. The system must be configured to support telnet sessions for the program to display. See “Setting User Telnet Options” on page 75 for details on defining telnet settings.

The following table lists the default settings for different program types.

**Table 3.2**  
Default Display Settings in .NET UI

Program Type	Web Logic Implemented	Type
Browses, lookups	Selected	Blank
Special HTML programs such as Browse Maintenance and Kanban workbenches	Selected	Blank
HTML reports and inquiries	Clear	Desktop
HTML maintenance programs	Clear	Desktop
Terminal-mode utilities	Clear	Blank

The Multi Domain field indicates a standard program that updates data that applies to all domains in a database. When this is selected:

- In the .NET UI, the string All Domains displays in the Menu Properties window for the associated menu program. Otherwise, the domain name displays.
- In the character UI, the string All Domains displays in the menu title bar when Header Display Mode is set to 2 or 3 in Security Control (36.3.24).

Appropriate default settings for the Multi Domain field are set during installation. For example, generalized codes apply to each domain separately so Multi Domain is not selected by default for `mgcodemt.p`. Country code data applies to the database as a whole so Multi Domain is selected by default for `adctrymt.p`.

**Important** You can update the setting for your custom programs or change it if you want the current working domain to continue to display even when a user is updating a table that applies across domains. This change affects what displays on the UI only. The program continues to update data for all domains.

### Adding Records

To execute a program with an HTML display from the .NET UI menus, add a record to Program Information Maintenance for each custom program. When a record does not exist for a program, the system assumes that it should run in Terminal mode.

If you want to create records for a number of programs at once, use Program Information Update (36.4.4.15) to scan them and automatically create records.

**Fig. 3.6**  
Program Information Maintenance (36.4.4.13)

To create program information records:

- 1 Enter a custom program name.
- 2 Indicate if this program updates data for all domains in the database.
- 3 Click Next to continue.
- 4 Select the Web Logic Implemented check box if this is a browse written according to QAD standards. Clear the Web Logic Implemented check box if this is a maintenance program, report, or inquiry that you want to display in HTML.
- 5 Leave the Type field blank for a browse. Specify Desktop for an HTML maintenance program, report, or inquiry.

### Program Information Update

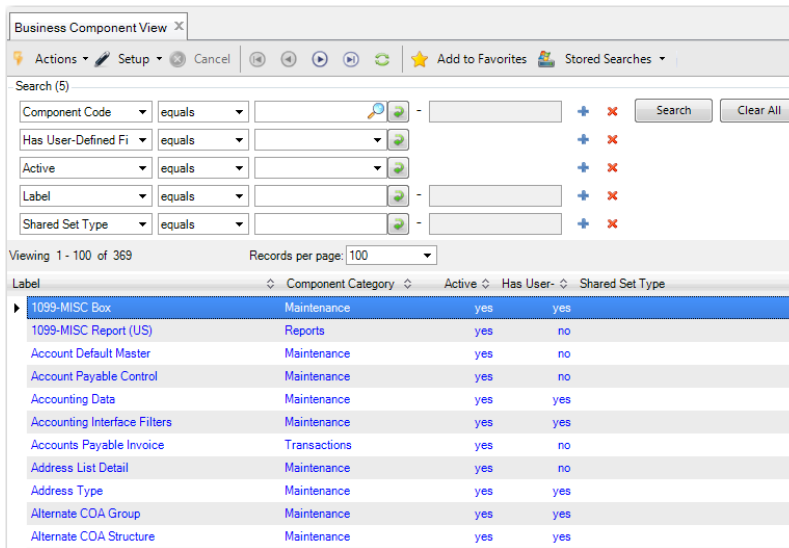
Use Program Information Update to automatically add records for custom programs to Program Information Maintenance. Use this utility as an alternative to adding records manually. It is especially useful for initially populating records with referenced tables.

**Fig. 3.7**  
Program Information Update (36.4.4.14)

### Viewing Business Components

Use Business Component View to view a list of the business components in the system. Not all business components are represented by activities in the system, so this gives you a complete view as well as displaying the technical name of the component. This might be needed in troubleshooting as well as developing API calls to the component.

**Fig. 3.8**  
Business Component View (36.4.4.22)



## Modifying Messages

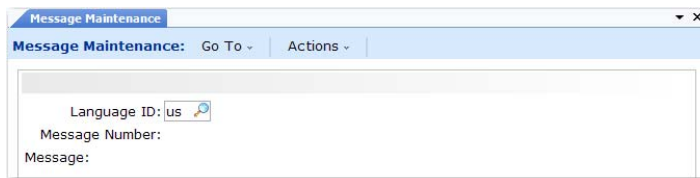
The system has three kinds of messages:

- Validation messages stored in the data dictionary. These display when the contents of the field do not match its specifications.
- Application messages for standard Progress programs stored in the database.
- Application messages for component-based programs stored in external resource files.

**Note** Numbered Progress error messages sometimes display when a Progress instruction fails. Most of these messages are handled by the system, and a system message is substituted, so this should occur rarely.

You can modify standard messages in Message Maintenance (36.4.6.1). One reason for changing messages is multiple language requirements. If a message seems unclear to some end users, an administrator can clarify its meaning. You can also add your own messages for custom code.

**Fig. 3.9**  
Message Maintenance (36.4.6.1)



Changing messages can create the same version control problems that occur when menus are changed. Be careful to use message numbers not likely to be used in a later product version. Messages in the ranges 9000–9999 and 90000–99999 are reserved for customer use.

## Creating and Managing Browsers

You can use system features to define browsers that display selected data in the form of a table. For more information on browse features, see *QAD .NET UI Administration Guide*.

Component-based functions have browsers that support extended configuration features. For more information on component-based browsers, see *Introduction to QAD Enterprise Applications User Guide*.

Standard browsers can display data from one table or from several tables joined into a specific view of the data. Use the functions on the Browse Menu (36.4.8) to manage browsers:

- Use Drill-Down/Lookup Maintenance (36.4.8.1) to attach browsers to program fields.
- Use User Tool Maintenance (36.4.8.5) to create links from one program to another.
- Use Stored Search Maintenance (36.4.8.7) to manage default browse information for component-based views.
- Use Browse URL Maintenance (36.4.8.9) to create links to other resources that can be accessed from a browse.
- Use Browse Maintenance (36.4.8.13) to create your own browsers or modify system supplied browsers.
- Use View Maintenance (36.4.8.18) to join information from more than one table to be used in a custom browse.

### Maintaining Drill Downs and Lookups

Two types of browsers are available in standard Progress programs:

- *Lookup browsers* return the value you select to the active field in the calling program.
- *Drill-down browsers* are more complex. They include more information and can display, filter, graph, or print data.

The field values in the browse can come from a table or a view. A *view* is a table that has selected values from one table or several joined tables.

Use Drill-Down/Lookup Maintenance (36.4.8.1) to assign drill-downs or lookups to fields that do not have a browse, to replace a browse, or to delete one.

See “Adding a Lookup” on page 19.

One of the most common uses of this program is to display generalized codes associated with a field. You can also assign lookups to any field that acts as an index to a maintenance screen. You may, however, need to write your own custom browse to find and display the data.

Most programs attached to a function with Drill-Down/Lookup Maintenance display values in a database table. But this is simply a convention. You can attach any Progress function to a field, and this program executes when the user selects Help. For example, you can attach the program `calculat.p` to field `pt_avg_int` to display a calculator.

Before you can use Drill-Down/Lookup Maintenance, you need to know:

- The name of the field where you want the browse to display.
- The name of the program using the field.

- The program name of the browse to attach. If a lookup is missing for a particular field but exists for a similar one, use Lookup Browse (36.4.8.3) to determine the program that displays appropriate field values. Then use Drill-Down/Lookup Maintenance to specify the same program for the similar field. See “Creating Browsers” on page 66 for details on creating browsers.

Determining the name of the program and field depends on the user interface.

- In the character interface, run the program. Note the program name in the upper left corner of the screen. Then place your cursor in the field where you want to attach the browse. Press Ctrl+F and note the field name.
- In the QAD .NET UI, find the program in the Application menu area, right-click on the program name, and select Properties. A screen displays program information, including the program name. To identify the field name, place your cursor over the field where you want to attach the browse on the program screen. The field name displays.

**Fig. 3.10**  
Drill-Down/Lookup Maintenance (36.4.8.1)

The screenshot shows a window titled "Drill-Down/Lookup Maintenance". The window has a menu bar with "Go To" and "ACTIONS". The main content area contains the following text and input fields:

- Drill Down/Lookup:Lookup
- Field Name: addr
- Calling Procedure:
- Procedure To Execute: gplu011.p
- Description Term:
- Description: Address Master
- Lookup Starts At Row: 7
- Lines In Lookup: 6

You can assign more than one drill-down to the same field. A menu of drill-downs appears when you request the drill-down. Only one lookup can be attached to a given combination of field and program name.

You can attach browsers to fields in any program, including another browse. Drill-downs can be nested. A field can call a browse that can call another browse that can call another browse, and so on.

Follow these steps to use Drill-Down/Lookup Maintenance to associate a drill-down with a field or program:

- 1 Select Drill Down in the Drill Down/Lookup field.
- 2 Enter a field name to associate with the browse in Field Name. Leave it blank to associate it with all fields.
- 3 Enter the program containing the field in Calling Procedure. Leave it blank to attach the browse to all programs using the specified field.
- 4 Enter the browse name in Procedure to Execute.
- 5 Optionally, enter a label term in Description Term. The long label contained in this term is displayed as the title in the browse. The default is the browse description term defined in Browse Maintenance. See “Creating Browsers” on page 66.

You access drill-downs differently in the two UIs:

- In the character UI, Select Drill Down from the Help menu or use Alt-Tab.
- In the .NET UI, click the underlined link that indicates a drill-down. When more than one drill-down is associated with a field, right-click to see a menu listing drill-down options or URLs.

Follow these steps to associate a lookup with a field:

- 1 Select Lookup in the Drill Down/Lookup field.
- 2 Enter a field name to associate with the browse in Field Name.
- 3 Enter the program containing the field in Calling Procedure. Leave it blank to attach the browse to all programs using the specified field.
- 4 Enter the browse name in Procedure to Execute.
- 5 Optionally, enter a description for the lookup. This description is for reference only and is not displayed in the lookup.
- 6 Enter the starting row and the number of lines to display in the lookup.

### Wildcards in Drill-Down/Lookup Maintenance

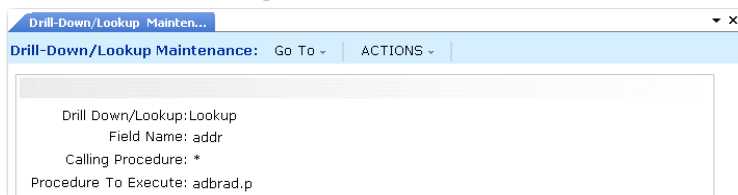
Use wildcards to attach browses to fields in multiple programs. For example, `pp*.p` attaches the drill down to the specified field in all programs starting with `pp` and ending with a `.p` extension.

The table displays the possible entries to Drill-Down/Lookup Maintenance:

Field	ad_addr	ad_addr	ad_addr
Calling Procedure	*	so*	soivmt.p
Procedure to Execute	adbrad.p	adbrcs.p	arbrbl.p

When you drill down on `ad_addr` in `soivmt.p`, a menu shows all three browses: `adbrad.p`, `adbrcs.p`, `arbrbl.p`. When you drill down on `ad_addr` in a program other than `soivmt.p` but beginning with the letters `so`, a menu shows two browses: `adbrad.p` and `adbrcs.p`. When you drill down on `ad_addr` anywhere else, the browse `adbrad.p` opens.

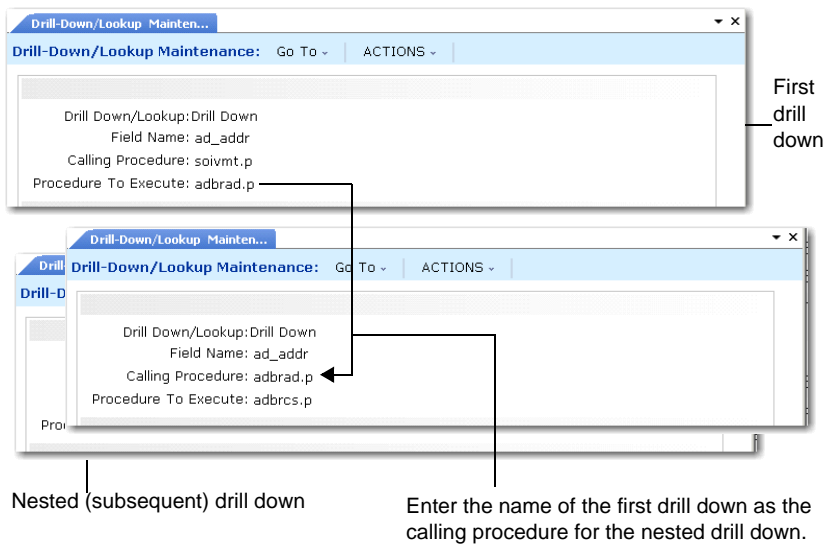
**Fig. 3.11**  
Wildcards in Drill- Down/Lookup Maintenance



### Drilling Down on Drill-Downs

You can nest drill-downs. In other words, one drill-down can call another, which can call another, and so on. After creating the first drill-down, you can assign the others to the same field. Enter the name of the first drill-down as the calling procedure for the nested drill-down.

**Fig. 3.12**  
Nested Drill Downs



### Planning for Upgrades

When you update your product version, be careful when loading `flh_mstr`. This table contains the records created by Drill-Down/Lookup Maintenance. If you have customized it, make sure that the new version does not overwrite your customization.

### Creating Access to Other Programs

User Tool Maintenance (36.4.8.5) lets you specify programs that can be run from other programs in the .NET User Interface. This makes it easier for you to run frequently used programs.

**Note** The relationships you define in User Tool Maintenance do not apply to any programs in the character interface and they do not apply to browses.

Use the Add Link command on the Go To menu from any HTML program in the .NET UI to access User Tool Maintenance. The links you define also display under the Go To menu. When you click a link, the linked program opens in a new tab.

**Note** You can also add links by accessing User Tool Maintenance directly from the menu. When you access it from a program in the .NET UI, the User ID and Program fields are filled in already.

## User Tool Maintenance

Figure 3.13 illustrates the User Tool Maintenance screen.

**Fig. 3.13**  
User Tool Maintenance (36.4.8.5)

- 1 Enter a user ID or leave the field blank to assign the link to all users.
- 2 Enter the name of the program where you want the link to display. Leave Program blank to add the link to all programs that do not already have a user-specific record. Click Next to continue.  
**Note** You can also use wildcards to specify where the links appear. Specifying pp\* places the links in all programs beginning with pp.
- 3 In the Exec fields, enter the program names (for example, adbr001) for the links to launch.
- 4 In the Label field, specify a text string to appear in the link area. If you leave this field blank, the standard menu description from Menu System Maintenance is used.
- 5 Leave the Image field blank. Images do not apply in the .NET UI.

## Displaying Links

You can assign programs to all users (blank user ID) or a specific user. You can also assign programs to a specific program or using wildcards. However, only one set of records displays when a user accesses a program. The system searches for the appropriate links to display in this order:

- 1 Specific user ID and specific program name
- 2 Specific user ID and program name with wildcards
- 3 Blank user ID and specific program name
- 4 Blank user ID and program name with wildcards

## Managing Stored Searches

Use the Stored Search activities (36.4.8.7) to manage stored searches created by users from various component-based browses. Each user can create stored searches so that they can quickly find records they want to view or update. Depending on the user's access, searches can be saved at three levels:

- For the individual user
- For all users assigned to a role
- For all users in the system

For more information on stored searches, see *Introduction to QAD Enterprise Applications User Guide*.

From the system administrative point of view, you can use the maintenance functions to:

- View stored search records that have been created by users.
- Delete stored search results. This might be necessary if a user leaves the company or a role is made obsolete.

**Note** Exporting stored search values is not currently implemented.

The system loads search and browse defaults during installation. Factory defaults display as a type of stored search, along with the last used customized settings. Use Export Browse Defaults to export default search and display settings into a `FactoryDefaults.xml` file. The system saves the file in the same folder that contains other QAD financial business logic.

## Defining Browse URL Links

Use Browse URL Maintenance (36.4.8.9) to create URL links that users can activate from .NET browses. When a browse cell contains a URL link, double-clicking it launches a new browser window and displays the intranet or Internet resource associated with the URL. You can use these URLs in two ways:

- Create links to external Web sites that users can activate from .NET browses, such as a supplier Web site associated with a supplier ID.
- Create links to other programs and pass specific data values to the programs. This lets you use browses as a means of navigating directly to maintenance programs.

You can access links to other programs only from drill-down browses, not lookups. Drill-down browses are typically available directly on the menu, but can also be associated with program fields in Drill-Down/Lookup Maintenance (36.4.8.1). See “Maintaining Drill Downs and Lookups” on page 56.

## Defining URLs to External Web Pages

Use Browse URL Maintenance to create links to external URLs with information that is related to items in the browse, as in the following example.

**Example** You want to establish a URL link in the Purchase Order Browse from supplier ID GS10100 to the corresponding supplier's company Web site, located at <http://www.generalsupplies.com>. To do this, enter the values in listed here in Browse URL Maintenance.

**Table 3.3**  
Sample Field Entries for Browse URL Links

Field Name	Value
Browse	pobr006.p
User ID	*
Field Name	so_vend
Value	gs10100
URL	http://www.generalsupplies.com
Description	General Supplies Web Site
Primary	Selected

URLs can contain special strings that are automatically replaced by field values in the browse. Selecting a link containing this type of string automatically replaces that string with the corresponding field value in the row.

Follow these steps to define this type of special string in a URL:

- 1 Enter #b# to indicate the beginning of the string.
- 2 After the #b#, enter a field name associated with the specified browse.
- 3 Enter #e# to indicate the end of the string.

**Example** The Web site for one of your primary suppliers contains a catalog of items. Entering an item's identifier at this Web site accesses the catalog entry for that item, containing information such as item cost, quantity available, and ship weight. To create links from the internal supplier item numbers to their corresponding catalog entries at the supplier's Web site, create the following URL:

*http://www.generalsupplies.com/catalog/#b#vp\_vend\_part#e#*

Then, associate it with the Supplier Item column in the Supplier Item Browse. After you establish this link, selecting a supplier item number in the Supplier Item Browse automatically inserts the selected field value.

For example, selecting supplier item 10-1005 creates this URL:

*http://www.generalsupplies.com/10-1005*

The system then launches a Web browser to display the relevant catalog information for that item located at that URL address.

#### Adding Another URL for the Same Browse

After you create a browse URL, you can use Browse URL Maintenance to create subsequent URL records for the same browse.

- 1 In the Browse field, choose the browse to which you want to add another URL.
- 2 Click Next twice.
- 3 Clear the URL field.

**Important** To trigger the creation of a new record, you must start with an empty URL field.

- 4 You can enter the new URL manually or use the HTTP Parameters pop-up. See “HTTP Parameters Pop-Up” on page 65.  
To enter the URL manually, specify the new URL in the cleared URL field.  
To build the URL using the HTTP Parameters pop-up, leave the URL field blank.
- 5 Click Next to display the HTTP Parameters pop-up.
- 6 In the pop-up, enter the values required to build the URL.  
The system builds the URL, including the `run_html` setting, using the values you supply.  
If you have already entered the URL manually, the pop-up displays the constituent values for the URL.
- 7 When you have completed your updates, click Next.  
The system displays a Modify Existing Record prompt.
- 8 Choose the relevant action:  
Click No to create a new browse record.  
Click Yes to update the current record.

### Defining Links to Other Programs

Use Browse URL Maintenance to create links to other system programs, as in the following example.

You can set up links in an item browse to directly access Item Master Maintenance (1.4.1), passing the current item number to the maintenance program, and executing the Next command any number of times. When a user clicks the link, Item Master Maintenance displays in a separate tab.

Multiple columns of data in a browse can contain links so that you can access maintenance programs for any data related to a record. However, data for only one field can be passed to each program.

To support this kind of URL link, use the `run_html` setting to indicate that you want to build a URL for system programs. The string must include the beginning and ending indicators required for other strings in URLs:

- 1 Enter `#b#` to indicate the beginning of the string.
- 2 Enter `#e#` to indicate the end of the string.

Then specify values that determine:

- The name of the program to be executed when a user clicks the link
- The field in the designated program to which you want to supply a value
- The value to be passed to the specified field
- The number of times the Next command should be executed in order to reach the field

To make it easy to build the URL, leave the URL and URL Script fields blank and click Next to display a pop-up that prompts you for the values required to build the URL. In this case, the system builds the URL including the run\_html setting using the values you supply.

**Table 3.4**  
Sample Field Entries for Browse Program Links

Field Name	Value
Browse	sobr009.p
User ID	*
Field Name	sod_part
Value	*
URL	Leave Blank
Description	Link to Item Master Maint.
Program Name	ppptmt
Field	pt_part
Value	sod_part
Index	2

The URL that the system builds based on these input values looks like the following example:

```
#b#run_html#e#?id=ppptmt.p&f=pt_part&v=#b#sod_part#e#&x=2
```

When the user clicks item 01053 in the `sobr009.p` browse, Item Master Maintenance displays with 01053 entered in the Item Number field and the active cursor focus is in the Name field below it.

### Using Browse URL Maintenance

The following figure illustrates Browse URL Maintenance.

**Fig. 3.14**  
Browse URL Maintenance (36.4.8.9)

The screenshot shows a window titled "Browse URL Maintenance" with a toolbar containing "Go To" and "ACTIONS". The main area contains the following fields and controls:

- Browse: sobr009
- User ID: \*
- Field Name: so\_nbr
- Value: [text input field]
- Description: Sales Order Maintenance
- Primary:
- URL: #b#run\_html#e#?id=sosomt.p&f=so\_nbr&v=so\_nbr&x=1
- URL Script: [text input field]
- Determine:

Use the following field descriptions to configure Browse URL Maintenance settings for your environment:

**Browse.** Enter the name of the browse program to contain the specified URL link.

Entering an asterisk (\*) in this field allows the specified URL to be associated with any browse in the system.

**Example** To associate a specific URL with the sales order number column in all .NET browses, enter an asterisk in this field and specify the sales order column's corresponding field name (so\_nbr) in Field.

**User ID.** Enter a user ID to associate with the specified URL link. To associate all users in the system with that link, enter an asterisk (\*) in this field.

**Field Name.** Designate the browse column in which you want to establish a URL link by entering the database field name associated with that column. The lookup associated with this field displays fields from the previously entered browse.

This field cannot be left blank.

**Value.** Specifying a value in this field associates the designated URL with every browse cell that contains that value and belongs to the browse column indicated in Field Name. Enter an asterisk (\*) to associate the URL with every cell in the column.

**Description.** Optionally enter a description to display when this URL is selected.

**Primary.** Select to indicate that the specified URL is the primary URL for a cell.

When you right-click a browse cell containing multiple URLs, a list displays for selection. The primary link displays at the top of the list in bold font and is the default link for the cell.

**Note** The value of Primary has effect only if no drill-downs are also associated with the cell. Drill-downs always take precedence over URLs and are listed first when you right-click.

This value applies to defined (non-scripted) URLs only.

**URL.** Specify a URL referring to an Internet or intranet location (maximum 132 characters). Leave blank to create a link to another program.

**URL Script.** To associate the specified user, browse, column, field value, or combination of these with a custom URL script, enter the full path to the directory containing the custom script. You cannot specify both a URL and a URL script. Scripts should be based on the supplied template `urltempl.p`, located in the source code directory, `/src/urltempl.p`.

**Determine.** Select this check box to have the system run the specified custom URL script upon selection of the associated cell or column to determine whether that cell or column has an associated URL.

When this field is clear, the script is not run and the designated column or cell is defaulted to having a URL.

#### HTTP Parameters Pop-Up

This pop-up displays when both URL and URL Script are blank and lets you specify a set of values used to access another program.

**Fig. 3.15**  
Browse URL Maintenance, HTTP Parameters

**Program Name.** Enter the name of the program to launch when a user clicks this link. You can include or omit the .p extension. For example, specify adcsmt or adcsmt.p.

**Field.** Enter the field in the program that you want to pass a value to from the browse; for example, enter cm\_addr to pass a value to the Customer Address field in Customer Maintenance. Only one field can be specified.

**Value.** Enter the field in the browse that contains the value that you want to pass to the named field. Use the beginning and ending delimiters for this value. For example, to pass the value of the sod\_part field in the Sales Order Browse (7.1.2) to the pt\_part field in Item Master Maintenance, enter #b#sod\_part#e#.

**Index.** Enter the number of times you want the system to execute a Next command when it invokes the program specified for Program Name. To access the first frame in a maintenance program, set this value to 1. If you set this to more than 1, all validations are executed before processing the Next command. If appropriate values do not exist for all required fields, an error is generated when you click the link.

## Creating Browsers

Use Browse Maintenance (36.4.8.13) to create custom browses or modify system-supplied browses.

When you create a browse, it is saved in your working directory as a source-code file. The source-code name is the first two characters of the name you entered, then the letters br or lu (depending on whether you selected power or look up), then any remaining numbers from the name you specified, then the extension .p.

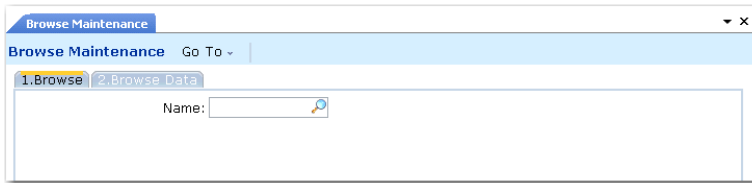
**Example** You create a power browse and name it ap010; the system names the code apbr010.p. If you selected both power and lookup browses, the system generates two source-code files: apbr010.p and aplu010.p.

Although you do not need to compile the source code of the browse, you should for better performance. If other users on your network want to use your browse, you must compile it and move it to the network directory. Use the Progress editor to compile the browse.

**Note** You can access the Progress editor only if your PROPATH is correctly set up to access source files.

Browse Maintenance has some special features that are not available in the character UI and that are not like other HTML programs. This section illustrates the program in the .NET UI.

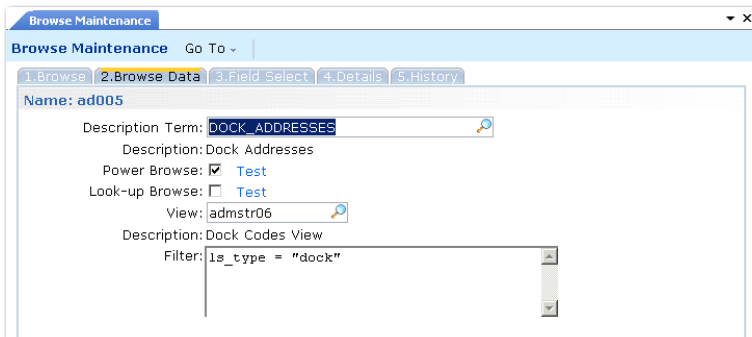
**Fig. 3.16**  
Browse Maintenance (36.4.8.13)



To create or modify a browse:

- 1 Select or enter a name for the browse. To name the browse, enter two letters and click Next. Use the existing QAD module mnemonics or make up your own. The system gives the browse a name that increments by one the number in the file name of the last browse created.
- 2 Click Next or click the second tab, Browse Data, to continue.

**Fig. 3.17**  
Browse Maintenance, Browse Data



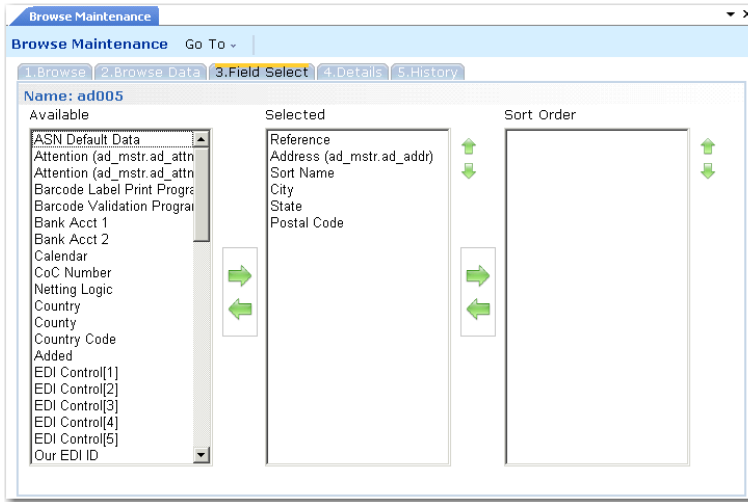
- 3 Enter a label term in Description Term. The long label contained in this term is displayed as the title in the browse window.
- 4 Indicate whether this is a power browse, lookup browse, or both.
- 5 In View, enter the name of an existing view or a primary table whose data the browse displays. You can see only those views you have access to. If a view exists for a table and the view name is the same as the table name, you have access to only those fields that are available in the view. See “Creating Views” on page 70.
 

**Note** The view name you enter in View must already be defined in View Maintenance, or you must enter a primary table name.
- 6 In the Filter field, type the selection criteria (optional) to limit the browse’s search to records that meet a certain condition. Do not put a period (.) at the end of the criteria, because the system adds a `no-lock no-error` statement to the criteria.

The Preview function, accessed with a button in the character user interface, is accessed by clicking one of the Test links next to the Lookup Browse and Power Browse check boxes. This displays the currently edited browse in a new tab. For existing browses, you can preview the browse before changing it.

Use the Field Select tab to select fields to be included in the browse and specify the display order.

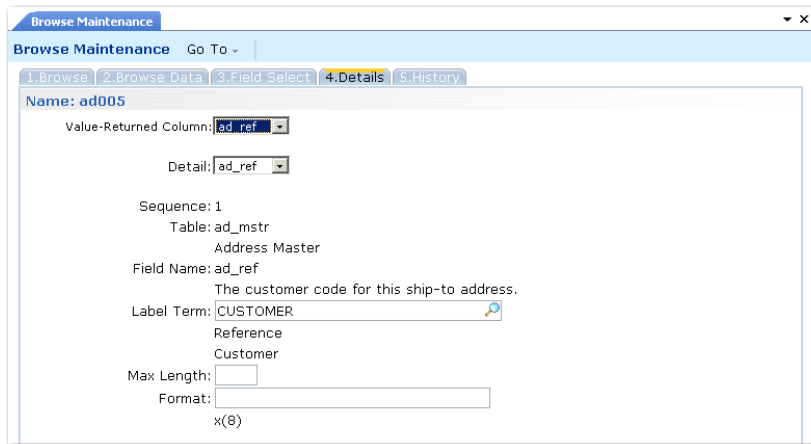
**Fig. 3.18**  
Browse Maintenance, Field Select



- 7 Fields from the view or primary table entered in the Browse Data frame display in Available Fields. Include up to 20 fields in your new browse.
  - In the .NET UI, move fields from one list to another by clicking the field to select it and clicking the arrow that indicates the appropriate direction. Multiple fields can be selected by holding down the Shift key and clicking. Use the Move Up and Move Down buttons to arrange the fields in the Selected Fields list.
  - In character mode, select a field to include in your browse by using the Up and Down keys to locate it and then press Enter. Multiple fields can be selected. Use the Tab key to choose the Add, Field Help, or Done buttons or to navigate between the Available Fields list and the Selected Fields list.
- 8 In the .NET UI, to specify sort columns—for look-up browses only—select one or more fields in the Selected column and click the right arrow to move them to the Sort Order column. You can use the up and down arrows to reorder the fields in the Sort Order list. The look-up browse sorts the records on the first column you enter in the Sort Order field.
 

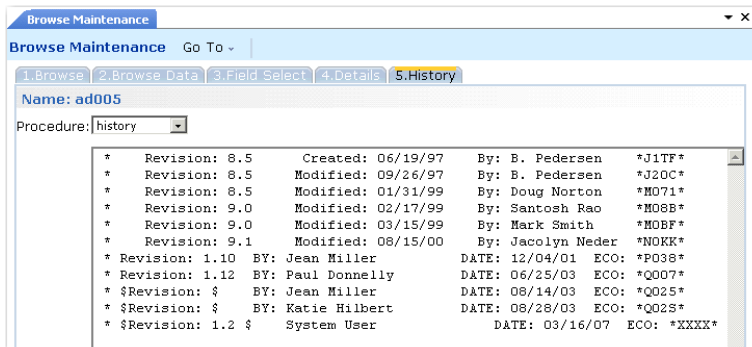
In the character UI, use the Sort Columns field to enter the columns you want to have available for sorting. Enter the columns as a comma-delimited list of up to seven numbers. The first field name in the Selected Fields list is column 1, the second is column 2, and so on.
- 9 When you have arranged the fields in the order you want, click Next to display the Details tab.

**Fig. 3.19**  
Browse Maintenance, Details



- 10 Enter the column number to take the field values from in Value-Returned Column (optional). The default is the first column of the browse.
- 11 To view the details related to a specific field, select it from the drop-down list in the Detail field.
- 12 If needed, you can change the default field label and format. To control the display length of a label, enter a Max Length value. Click Back if you want to view or modify data for other fields. Otherwise, click Next to display the browse history.

**Fig. 3.20**  
Browse Maintenance, History



- 13 The program automatically creates a revision history line containing a revision number, the user name (or logon ID), and current date. You can modify this as needed. The revision history is also saved in the source code.

**Note** The Procedure field offers other choices; only History is currently implemented.

- 14 Click Next to generate the browse.

## Creating Views

A view is a display of some or all of the fields from one or more tables. You join two or more tables for a view by specifying the relationships between fields in different tables and choosing the type of join to use.

Views are used in browses, which display the fields gathered using views. By choosing which fields to include or exclude in a view, you control which fields are available for a browse to display. By putting security on the view, you can allow users to modify browses, knowing that they can access only those fields that you have authorized.

Use View Maintenance (36.4.8.18) to create or modify views.

### Using Progress Syntax

You use some Progress syntax in creating or modifying views. You must also understand database table and field relationships.

To create or modify a view:

- 1 Select the table or tables to include in the view.
- 2 For sequences after the first, specify the type of join to use: inner or outer.
- 3 Join the tables using Progress logic.
- 4 Select fields from the tables.
- 5 Save the view.

Figure 3.21 illustrates how to create a view of selected fields from one table.

**Fig. 3.21**  
Creating a View from One Table

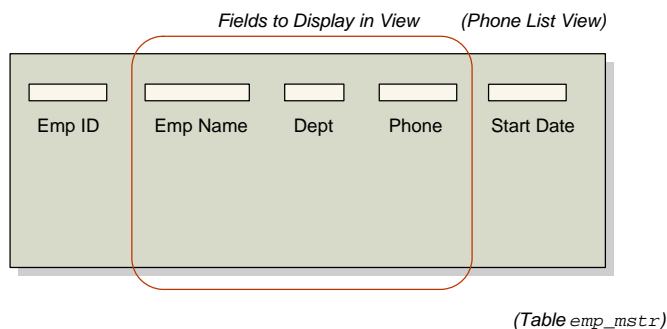
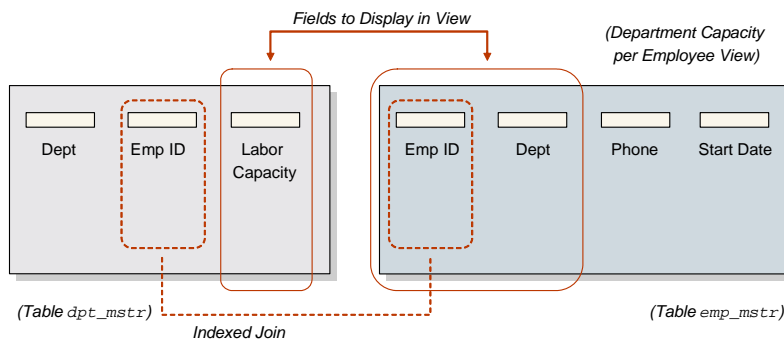


Figure 3.22 illustrates how to create a view of selected fields from two tables.

**Fig. 3.22**  
Creating a View by Joining Two Tables



## Using Join Types

When a view includes data from more than one table, you can choose from two types of joins when creating a view:

An inner join returns the records selected for the first table combined with related records selected from the second table. If a record does not exist in the second table, no records are returned. Only related records selected from both sides of the relationship display in the view.

An outer join returns the records found by an inner join. However, in addition, for each value in the first table, it returns unknown values from the second table when no related record is found. As a result, all matching records from the first table are preserved for unmatched records in the second table.

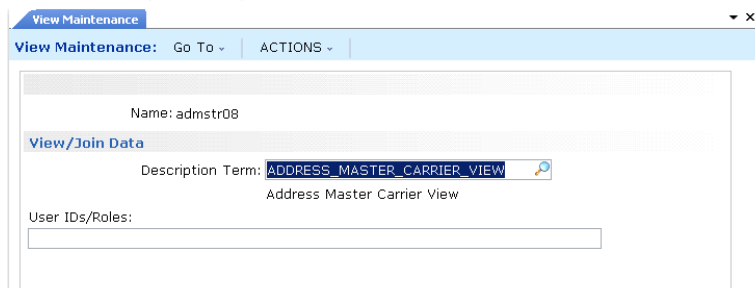
The default join type is inner. Using the outer join can give you more flexibility in displaying information.

**Example** An inner join between customers and sales orders displays only customers with sales orders. An outer join includes all customers, even those who do not have orders.

## Using View Maintenance

Figure 3.23 illustrates View Maintenance (36.4.8.18).

**Fig. 3.23**  
View Maintenance (36.4.8.18)



- 1 Select or enter a view name.
- 2 Enter a label term in Description Term. The long label contained in this term is displayed as the view label.

- 3 In User IDs/Roles, enter one or more user IDs or roles to limit user access to the view (optional). Enter multiple user IDs or roles by separating them with commas.
- 4 Click Next to continue.

**Fig. 3.24**  
View Maintenance, Table Selection

The screenshot shows a window titled "View Maintenance" with a sub-tab "Table Selection". The "Name" field contains "admstr08" and the "Sequence" field contains "2". Under "Table Selection", the "Table" field is "ad\_mstr" and the "Join Type" dropdown is set to "INNER". The "Join Phrase" field contains the SQL expression "ad\_domain = ls\_domain and ad\_addr = ls\_addr".

- 5 The number you enter in Sequence controls the order in which the table defined in Table is joined to the view.
- 6 Enter a table name.
- 7 If the sequence is not 1, specify the type of join, either inner or outer. The Join Type field is only enabled when the sequence number is greater than 1.
- 8 Enter or edit the phrase to join the tables. Use proper Progress syntax. Do not include a Where verb. Join phrases express the field relationships between tables (see Figure 3.22). For a faster display of fields, use indexed fields in the Join Phrase.
- 9 Click Back.

**Fig. 3.25**  
View Maintenance, View Field Data

The screenshot shows a window titled "View Maintenance" with a sub-tab "View Field Data". The "Name" field contains "cmhhist01", the "Table" field contains "cm\_mstr", and the "Field Name" field contains "cm\_region". Under "View Field Data", the "Label Term" field is empty, the "Format" field contains "x(4)", and the "Data Type" dropdown is set to "character". The "Expression" field is empty.

- 10 In Field Name, enter a field from one of the tables in the view or enter a local variable. When entering a local variable, name it `local-varnn`, where `nn` is a number incremented by one from the last defined variable.

For example, you see from the lookup browse that the last local variable was `local-var05`; you name your local variable `local-var06`. Use local variables when you want to return a value resulting from an operation on two fields; for example, the quantity required minus the quantity open. Define the operation in Expression.

- 11 If you entered a local variable in Field Name, enter its Label Term, Format, and Data Type.

**Note** Search for a label term by entering a portion of a label, then use Next/Previous to display available records.

- 12 If Field Name is a local variable, you can enter Progress syntax in Expression to define the local variable. Valid expressions include:

- `field1 + field2` (computation, where `field1` and `field2` are fields within the record)
- `>`, `<`, `>=` (operands that perform comparisons)
- Progress functions, such as `substring (field1,1,4)` or `round (field1,1)`

**Note** Incorrect syntax terminates your session if you attempt to use the view.

## Defining User Menu and Function Keys

User menu and function keys are available in the character UI. In the .NET UI, users set up personalized menus with the Favorites functionality.

Assigning function keys to frequently used menu items is another way to execute programs quickly in the character user interface. Keys can be established for all users or individually customized. Up to 999 function keys can be defined. In addition, you can change the standard label for a menu item to customize menu labels for each user.

**Note** Function keys apply only to the character interface.

**Example** A user entering a sales order may need to check on the available-to-promise (ATP) quantities for an item before indicating a due date. By setting up a function key for the Master Schedule Summary Inquiry (22.18), the order clerk can review an item's ATP quantity without leaving Sales Order Maintenance (7.1.1).

**Note** Do not use function keys or the function menu to access a maintenance screen in the character environment. Progress only completes transactions initiated with function keys after the initial transaction is completed. If, for example, you are in sales orders, you start an order, then perform an inventory transaction using a function key, and then cancel the sales order, the inventory transaction is also canceled.

Access programs associated with a function key by selecting that function key. Function keys F1 through F12 are reserved for system use, so the assigned key must be F13 or higher. Since many keyboards do not handle that number of function keys, this option is used less frequently.

### User Menu

Access the User Menu by pressing F6. A list of menu items set up for your user ID appears. Choose the one you want by highlighting it and pressing Enter or F1. Press Tab to sort the list by menu number or function name. Press F4 to display the user menu items defined without a user ID.

**Note** There is no relationship between the order of items on the User Menu and the function key assigned, and the function key is not shown. Menus sort lexically, so that 13 appears before 2 if you are in the Menu Selection column.

Different environments have different function key uses and limitations. Set up your system according to your environment. For example, if your system is limited to only 12 function keys, do not attempt to use the function keys as a quick method to launch programs. Instead, use the User Menu.

## Executing Programs in Sequence

In the character interface, you can make several programs execute in sequence by assigning them to the same function key and giving each a different sequence number. When you press that function key, the first function in the sequence executes. When that function is finished, the next one in sequence is called automatically.

**Important** All transactions in the sequence must be completed before data is updated in the database.

## User Function Maintenance

Set up user menus and function keys in User Function Maintenance. Each selection on the user menu should have a different function key reference, from 13 to 40, and a zero or blank sequence number. The function key reference must be 13 or greater, even if your keyboard supports fewer function keys or you plan to access selections through the User Menu.

**Note** To set up function keys, terminals must be compatible with the Progress protermcap file.

## Using Field and Program Help

The system provides two types of online help: program (also called procedure) and field help. Program help explains what the current function or program you are working within does. Field help describes particular fields.

You can view these help records in either HTML or character format. The content of the HTML and character help files is identical. You can add your own information to the help; it displays under a heading of User Help in both character and .NET UI.

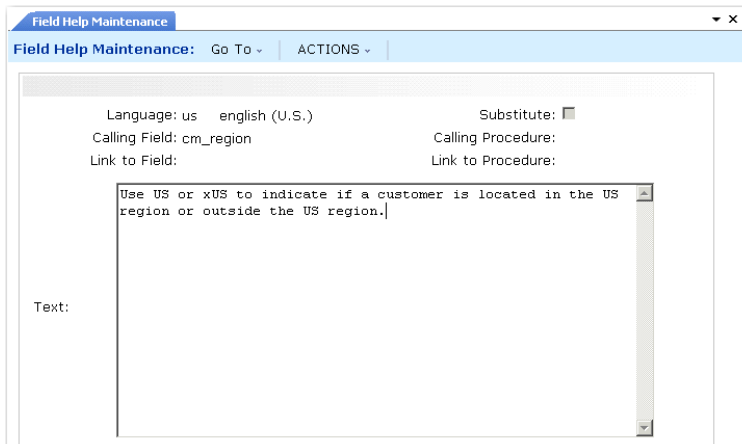
**Note** QAD .NET UI displays the character help data in an HTML format. Any changes you make to character help are also visible in the QAD .NET UI.

In the QAD .NET UI, view field and program help by pressing F1. In the character interface, view field help by pressing F2 with the cursor in the field. Press F2 a second time and program help displays. No keyword searches or hypertext links are available in character help.

## Adding User Help

Use Field Help Maintenance (36.4.13.1) to add to the character-format help delivered with your system.

**Fig. 3.26**  
Field Help Maintenance (36.4.13.1)



Custom text entered in Field Help Maintenance appears at the top of the help record.

## Printing Help

You can print out portions of the field and program help to supplement your user guide set. Printed field help is available through Field Help Report (36.4.13.2). The Procedure Help Report (36.4.13.4) prints program help in alphanumeric ranges by program name.

The Field Help Book Report (36.4.13.3) enables you to print a book containing all field help. Choose units as small as one field and as large as an entire module.

*Local Vars.* Clear this option to exclude local variables. These are field names created within a program, not drawn from the data dictionary. In reports, the From and To fields are often local variables. Usually, help for local variables is not as significant as database fields.

*Update Only.* Select this option to limit output to fields that can be changed.

*Where-Used, Maximum.* Disable the Where-Used option to keep the system from printing a where-used list after each help item. Some database fields are used throughout the database, and a complete where-used list can be very long. If selected, limit the length of the where-used list by entering a value in Maximum.

## Setting User Telnet Options

As part of system installation, telnet setup scripts are configured for use by the Connection Manager for managing HTML programs running under the .NET UI. Create additional telnet scripts for running terminal sessions within the QAD .NET UI with User Option Telnet Maintenance (36.4.14).

The QAD .NET UI also reads other settings in this program, including the port value defined in this program to determine which port to use to connect to the server for terminal programs.

Configuring the settings in User Option Telnet Maintenance consists of the following tasks:

- Specifying telnet server settings
- Defining the login sequence
- Configuring the telnet connection settings
- Verifying the script login sequence

## Configuring Telnet Server Settings

Figure 3.27 depicts the User Option Telnet Maintenance (36.4.14).

**Fig. 3.27**  
User Option Telnet Maintenance, Telnet Options (36.4.1.4)

The screenshot shows a web-based configuration window titled "User Option Telnet Maintenance". The window has a header with "Go To" and "ACTIONS" menus. Below the header, there is a "User ID: \*" field. Underneath, a section titled "Telnet Options" contains several input fields: "Host" (with the value "colli43"), "Host O/S" (a dropdown menu with "UNIX" selected), "Port" (with the value "23"), "Image" (an empty text field), "Script Timeout" (with the value "240"), and "Idle Timeout" (with the value "240").

Use the following instructions to configure telnet server settings:

- 1 In User Option Telnet Maintenance, create a record that applies to all users by entering an asterisk (\*) in the User ID field; then click Next.
- 2 Enter values in the following fields

*Host.* Enter the fully qualified machine name or IP address of the telnet server. The script uses this information to establish the telnet connection.

*Host O/S.* Enter UNIX for UNIX systems. Enter NT for Windows systems.

*Port.* Enter the port number for the telnet server. The default value is 23. This is the value you would normally use, unless you are using SSH under the .NET UI. In this case, the port value is 22.

*Image.* Leave this field blank; it is not currently used.

*Script Timeout.* Enter the number of seconds (1–999) the system waits for the telnet login script to execute. If this value is exceeded, a time-out message displays and the session closes.

*Idle Timeout.* Enter the number of seconds (1–999) the system waits after a telnet session begins for a program to execute.

**Note** Idle timeout is not used in the QAD .NET UI.

## Define the Login Sequence Script Lines

For users to be able to log in to and begin a telnet session on the telnet server, you must provide the sequence of telnet server login prompts and responses. The last value in the sequence specifies the script you created during system installation.

Terminal mode supports either operating-system level or script user credentials based on the setting of `TerminalAuthentication` in `qaduiConfig.xml`, located in:

`TomcatInstallDir/webapps/qadhome/client/configs`

- When this is set to `ShellUser` (the default), the user ID and password used to login to the .NET UI are used for the terminal login, regardless of what is set in this program.
- When this is set to `ScriptUser`, the user ID and password defined in User Option Telnet Maintenance is used.

When defining paths for scripts used in the .NET UI, avoid using relative paths since each user's access may be different.

**Fig. 3.28**  
User Option Telnet Maintenance, Login Script Line

The screenshot shows a web application window titled "User Option Telnet Maintenance". The page has a header with "Go To" and "ACTIONS" menus. The main content area is divided into several sections:

- User ID:** A text input field with an asterisk (\*) indicating it is required.
- Telnet Options:** A table with four columns: Host (value: coli43), Port (value: 23), Image (empty), and Script Timeout (value: 240). Below the table, there is an Idle Timeout field (value: 240).
- Script Lines:** A section with a "Sequence:" label and a text input field containing the number "1".
- Script Lines Data:** A section with three fields: "Script Pattern:" (value: login:), "Script Value:" (value: netui), and "Script Status:" (empty).

- 1 Specify the telnet login sequence number in the Script Lines frame. For each telnet command, enter a sequence number beginning with 1, and click Next. In the next frame, enter the following:

**Script Pattern.** Enter the prompt generated by the telnet server when a telnet login occurs. The values in this field must be identical to the prompts the telnet server displays when users log in.

**Script Value.** Enter the response to the telnet login prompt defined in Script Pattern.

**Script Status.** Optionally enter a description of the prompt and response; for example, Logging In.

If you have tracing enabled and the Java console is displayed, the description in the Script Status field displays in the Java console on the client when an error occurs during the execution of the prompt and response. You can use these descriptions as an aid in troubleshooting telnet session issues.

**Note** Script sequence 2 has special validation for suppressing password display. When you enter a password as a script value, only blanks display. When you click Next at the end of the sequence, you are asked to confirm the password.

- 2 Click Next after entering the sequence values. You return to the Sequence field to enter the next sequence number and values.

**Fig. 3.29**  
User Option Telnet Maintenance, Second Login Script Line

The screenshot shows a web-based configuration window titled "User Option Telnet Maintenance". The window has a header with "Go To" and "ACTIONS" menus. The main content area is divided into several sections:

- User ID:** \*
- Telnet Options:**
  - Host: col43
  - Host O/S: UNIX
  - Port: 23
  - Image:
  - Script Timeout: 240
  - Idle Timeout: 240
- Script Lines:**
  - Sequence:
- Script Lines Data:**
  - Script Pattern: login:
  - Script Value: netui
  - Script Status:

- 3 After entering the final sequence, click Next to return to the Sequence field. Then click Back to move to the Telnet Connections fields.

## Configure Telnet Connection Settings

Once you configure and verify your telnet login sequence, access the Telnet Connections frame and specify telnet connection settings. These settings define the maximum and minimum number of telnet connections available to the associated user.

Recommended settings are 10 or more for Maximum; 1 for Minimum.

**Fig. 3.30**  
User Option Telnet Maintenance, Telnet Connections

The screenshot shows a web-based configuration window titled "Telnet Connections". It contains two input fields:

- Maximum:
- Min Telnet Connect:

*Maximum.* This value specifies:

- The maximum number of concurrent embedded telnet screen connections this user can have open per session.
- The maximum number of running HTML programs allowed for the user. If a specific record does not exist for a user with this setting defined, that user can continue opening programs until the maximum number of sessions allowed for the entire pool is reached.

Valid values are:

- Unlimited: The associated user can have an unlimited number of concurrent telnet connections open.
- Disabled: The associated user cannot log in through .NET UI. Until you create a login script to initiate telnet sessions for this user, you cannot set this field to any value other than Disabled.
- Any numerical value between 1 and 99.

**Note** Setting this to 0 is the same as disabled.

This setting applies separately to HTML telnet sessions and terminal sessions in the .NET UI. For example, if Maximum Telnet Settings is 5, a user can have 5 HTML maintenance programs running and 5 telnet programs running in one session before an error displays.

*Minimum.* Enter a value between 0 and 9 to indicate the minimum number of telnet connections to be available to the associated user at all times.

Set this value to the number of telnet programs the user is likely to run simultaneously. Specifying a value here can dramatically reduce the wait time for these programs to display. However, setting this value too high depletes system resources.

QAD recommends that you set Minimum to 0 (zero) for most users, including the generic user—defined with an asterisk (\*). If users access terminal maintenance programs extensively, set Minimum to 2.

## Verify the Login Sequence

To verify the login sequence, from a remote machine attempt to log in to the telnet server using the login sequence you configured in the system. Login is successful if the system displays a blank telnet screen after the telnet connection script is launched.

## Modifying Labels

The system dynamically reads the label master table to determine the appropriate labels to display on screens and reports. For the system to display labels from the label master, Translate Frames must be selected in Label Control (36.4.17.24). Otherwise, screens and reports display field labels statically from the source code.

You can modify how labels display in Label Master Maintenance (36.4.17.1). You may want to modify labels in order to meet specific company needs or to improve definitions of non-English labels.

**Fig. 3.31**  
Label Master Maintenance (36.4.17.1)

The screenshot shows a web-based form titled "Label Master Maintenance". The form contains the following fields:

- Language ID: us english (U.S.)
- Term: &AVAILABLE\_FIELDS
- Long Label: &Available Fields
- Medium Label: [text input field]
- Short Label: [text input field]
- Stacked Label: [text input field]
- Description: [text input field]

The system validates the language code and accesses the *term*. The term is the key that links labels to fields, allowing the system to determine which labels to display. The term remains the same regardless of the language selected.

Terms display in all uppercase with underscores; for example, CALCULATE\_DUE\_DATE is the term for Calculate Due Date when the language code is US (American English).

Use Label Detail Maintenance (36.4.17.5) to assign terms and labels defined in Label Master Maintenance to fields generically or to fields in specified programs.

**Warning** Because terms can be assigned to fields accessed by many programs, label modifications and new term assignments should be made with extreme caution.

## Building an E-Mail System Interface

Some functions can be configured to send e-mail messages to designated users. For example, optional e-mail messaging is used in System Security, Product Change Control, Supplier Performance, and the Global Requisition System. Additionally, you can have the system send report output in an e-mail message and you can send links to programs using e-mail.

**Note** Certain component activities also send preconfigured e-mail. This is discussed in “Configuring E-Mail Notification for Components” on page 82.

To take advantage of this feature, the e-mail system must be defined and addresses specified. The e-mail interface is built around an operating-system command that communicates with the user’s e-mail system. This command tells the e-mail system how to construct and address messages.

### Setting Up E-Mail System Interfaces

There are two ways to set up e-mail:

- Use text e-mails.
- Convert documents to HTML and e-mail them as mail attachments.

The following topics discuss these methods.

### Using Text E-Mail

With text e-mail, you cannot inform e-mail clients, such as MS Outlook or Lotus Notes, in which code page the data resides. So, for Unicode or non-English environments, the e-mail client determines the code page of the text. In most cases, if the text does not display correctly, you can right-click within the e-mail to access the code page; for example, in MS Outlook, you can right click to select Other Actions, then Encoding, then select the character set to access. In Lotus Notes, you can right click to select Encoding, then Other, then select the character set.

### E-Mailing Attachments

You can convert the text to HTML, then convert to UTF-8 to make an attachment. When you open the e-mail attachment in your Web browser, the attachment displays correctly.

**Note** The UTF-8 code page is part of the Unicode standard. See “Using Multiple Languages” on page 45 for details.

To use HTML e-mail, you must use an e-mail command that supports attachments, like the command for attachments for the Mutt e-mail client. Mutt is a free, text-based program for reading electronic mail under the UNIX or Linux operating systems. Mutt provides a `-a` option for attachments.

If you want HTML e-mails as an attachment, you must add the `-a` option to the Mutt configuration file. Once the command is added to the configuration file, you can send text e-mails with an attachment by pressing the less than (<) key.

## E-Mail Definition Maintenance

Set up a command line in E-Mail Definition Maintenance (36.4.20) for each system you want to access. Then, in User Maintenance (36.3.1), specify an e-mail definition and address for each user. The system uses the address as the sender of e-mail messages.

Be sure that an output device is defined in Printer Setup Maintenance (36.13.2) that has Destination Type set to Email. This is described in “Setting Up Printers” on page 90. When you select the associated device in the Output field in programs throughout the system, the resulting report is sent to specified e-mail addresses.

Before you implement E-Mail Definition Maintenance (36.4.20), refer to the e-mail application documentation or consult with your e-mail system administrator to determine if the application you are using provides an operating-system command interface. If it does not, various shareware products provide e-mail command-line interfaces.

**Fig. 3.32**  
E-Mail Definition Maintenance (36.4.20)

**E-Mail System.** Enter an alphanumeric code that identifies an e-mail system your company uses. This can be a number or a shortened version of the application name. You can use the same code for more than one record to give users access to multiple systems. For example, you can define both a UNIX system and a Windows system with the same code so that a user can log on to either system with the same user ID.

**Operating System.** Enter the name of the operating system on the user’s computer. This is not necessarily the same operating system as the computer where the QAD databases reside. Valid values are UNIX and WIN32.

**Start Effective.** Optionally enter the first date this system is available for use.

**Description.** Enter a brief description of this system.

**Path and Program Name.** Enter the complete path to the executable e-mail application file; for instance:

F:\apps\shared\email\blat.exe

**End Effective.** Enter the last date this system is available for use. This is an optional field.

## E-Mail Command Parameters

Command line parameter fields can store parameters or arguments to identify the type of data being passed to the command. The parameter is a prefix, which is followed by the type of data. The UNIX `mailx` command, for instance, requires that the subject of the message have a `-s` prefix, as in the following example:

```
mailx -s "test message"
```

E-Mail Definition Maintenance defines four parameters: Sender, Recipient, Subject, and Message Text File (or Message Text String). Use the message parameters required by your e-mail system. You can use either a text file or string or both, as needed.

The Sequence fields control the order in which the Sender, Recipient, Subject, and Message Text parameters appear in the command line. Some e-mail systems require these parameters in a specific order. If your system does not use one of the parameters, leaving both the Parameter and Sequence fields blank omits that parameter from the command line.

If you enter a parameter without a sequence, the parameter is not included on the command line. If you enter a sequence without a parameter, the system skips this parameter and creates the command.

The E-Mail Command field displays the system-built Path and Program Name, Parameters, and Sequence.

When you complete the setup for your e-mail system, you are prompted to send a test message. The default addressee is your log-on user ID. If you have not yet entered your e-mail address in User Maintenance, the system prompts you for an address.

## Customizing Appearance of HTML E-Mail

If you are receiving e-mail in the form of standard MIME attachments, you can customize the appearance of HTML-based messages by modifying the style tag in the `email.css` cascading style sheet. This file is located in the `InstallDir\src` directory. You should move the file so that it can be found in the `PROPATH`.

You can modify color and font by updating the following values:

```
<style>
  BODY { margin: 0; COLOR: #000000; FONT-FAMILY: Courier, Arial, Geneva,
    sans-serif; BACKGROUND-COLOR: #FFFFFFE }
  PRE { COLOR: #000000; FONT-FAMILY: Courier, Arial, Geneva, sans-serif;
    BACKGROUND-COLOR: #ffffee }
</style>
```

## Configuring E-Mail Notification for Components

You can configure the system to send notification e-mails to recipients with the relevant roles when customer, supplier, employee, or end-user records are created.

**Note** This same e-mail configuration is used for sending work items to recipients if you are using the optional workflow. See “Configuring Workflow” on page 159 for details about enabling workflow.

The system notifies users of an event when they have the appropriate role and belong to the same domain as the item being created. In the case of supplier, customer and end users components, this is extended to include all users for each domain associated with the shared set referenced by the component. A user configured to receive an e-mail notification receives an e-mail for each domain in which the component is replicated.

Users receive separate e-mail notifications for each event for which they have the relevant role. For example, if two employee records are created, users with an employee notification role receive two separate e-mails—one for each of the new records.

Users who are to receive notifications must belong to the roles listed in the following table.

**Table 3.5**  
Events and Corresponding Roles

Event	Role
Creation of new employee record	EmployeeNotify
Creation of new supplier record	SupplierNotify
Creation of new customer record	CustomerNotify
Creation of new end-user record	EndUserNotify

To use e-mail notification, a running SMTP (e-mail) server must exist. The location of the SMTP server is specified in the `server.xml` file. A sample configuration is shown below:

```
[ SMTP ]
SmtpServer=smtp.qad.com
SmtpPort=25
SmtpSender=financials@company.com
```

It is not necessary to specify the values for `SmtpPort` and `SmtpSender`. The SMTP port defaults to 25 (standard port for SMTP service) and the SMTP sender defaults to `mfgpro@qad.com` (this is primarily for having a default sender for development environments). Generated e-mail notifications are sent as though they originate from the specified SMTP sender. The e-mail address specified for the sender need not be a valid e-mail address.

If the e-mail (SMTP) server used to process the e-mail notifications is not available, the e-mails cannot be sent and the system returns a notification message to the user creating the component.

The system uses the e-mail address specified in User Maintenance (36.3.1) for the users that are members of the role to receive notification. If this address is invalid, the user does not receive any notification e-mails and no error is generated.

If the e-mail server used for notification is not available, the e-mails are not sent and are not queued for later delivery. In this case, a message is returned to the user creating the component to make them aware of the problem.

## Using Advanced Reporting Tools

Use programs on the Report Setup Menu (36.4.21) to support advanced reports and dashboards designed using the Cognos reporting tool. Additionally, several QAD-designed dashboards are available with QAD Business Intelligence 2.5 and higher. See *QAD Business Intelligence User Guide* for detailed information on these programs.

Dashboards add an interactive element to reports. They let you:

- Drill up and down to see higher and lower levels of detail.
- Include multiple charts derived from different data sources in a single report.

**Important** Although the setup menu is also available in the character UI, you can only view the resulting reports and dashboards through the QAD .NET UI.

## QAD-Provided Dashboards

If you have purchased QAD Business Intelligence 2.5 or higher and the appropriate supporting elements, you can implement several QAD-provided dashboards. See *QAD Business Intelligence User Guide* for detailed requirements and procedures.

## Custom Reports and Dashboards

You can implement custom reports and dashboards without using QAD Business Intelligence, as long as you have installed the following components:

- QAD .NET User Interface
- QAD ReportNet Bundle, delivered with the QAD .NET UI
- Cognos 8.2

Use the following workflow to implement custom reports and dashboards.

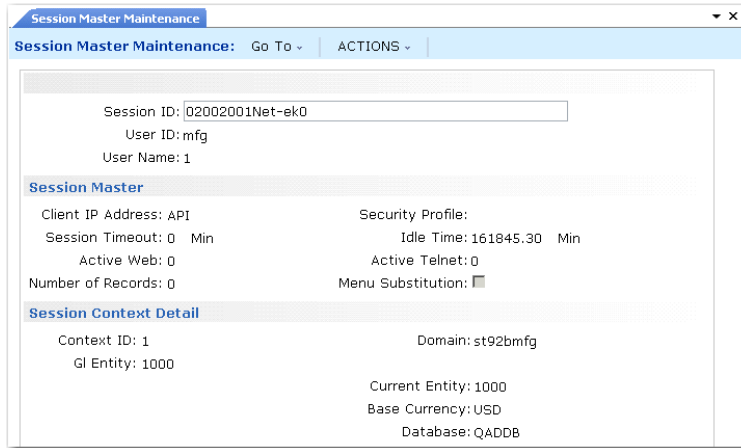
- 1 Set up the QAD report server after installing Cognos 8.2.
- 2 Create reports and dashboards using Cognos Report Studio. See *Cognos BI 8 Report Studio User Guide* for details.
- 3 Configure report settings and perform report synchronization using programs on the Report Setup Menu:
  - a Use Report Control (36.4.21.24) to configure report server settings and view or modify URL parameters.
  - b Use Report Synchronization (36.4.21.2) to synchronize reports between the system and the report server.
  - c Use Report Parameter Synchronization (36.4.21.4) to synchronize report parameters in the system with the report server.
- 4 Create menu entries for the new reports using Menu System Maintenance (36.4.4.1).

## Monitoring User Sessions

Use Session Master Maintenance (36.4.22) to view information about users who are currently logged in to the system through the .NET UI. This information displays in the form of session records, each identified by a unique session ID that is generated by the system. A session record is automatically created when a user successfully logs in to the system from the .NET UI and is deleted when the user logs out.

Session times are recorded and displayed in Universal Time, Coordinated (UTC).

**Fig. 3.33**  
Session Master Maintenance (36.4.22)



Session Master	
Session ID: 02002001Net-ek0	
User ID: mfg	
User Name: 1	
Client IP Address: API	Security Profile:
Session Timeout: 0 Min	Idle Time: 161845.30 Min
Active Web: 0	Active Telnet: 0
Number of Records: 0	Menu Substitution: <input type="checkbox"/>

Session Context Detail	
Context ID: 1	Domain: st92bmfg
GI Entity: 1000	Current Entity: 1000
	Base Currency: USD
	Database: QADDB

Only some of the settings displayed on this screen apply to .NET UI sessions. You can ignore the following: Active Web, Number of Records, Security Profile, Active Telnet, Menu Substitution, and Context ID.

The session context detail displays information about the current workspace (domain). One user session can be associated with multiple contexts if programs have been activated in more than one workspace.

You can also monitor the status of sessions for HTML maintenance programs, reports, and inquiries using Connection Manager, which is described in detail in the installation guide for your system.



# Printers

This section describes how to set up and use printers.

***Introduction to Printer Management 88***

Introduces the Printer Management menu.

***Defining Printer Types 88***

Explains how to use Printer Type Maintenance.

***Setting Up Printers 90***

Explains how to use Printer Setup Maintenance and define a printer for use with the QAD .NET UI.

***Setting Default Printers 92***

Explains how to use Printer Default Maintenance.

***Defining Document Formats 92***

Explains how to define document formats.

## Introduction to Printer Management

You can send reports, inquiries, and browses to a variety of printers—both local and network. The Printer Management menu (36.13) contains programs for setting up system printers and default printers by user or group. Printers apply to all domains in a database.

## Defining Printer Types

Before setting up printers, define printer types using Printer Type Maintenance (36.13.1).

**Fig. 4.1**  
Printer Type Maintenance (36.13.1)

The screenshot shows a window titled "Printer Type Maintenance" with a menu bar containing "Go To" and "ACTIONS". The main content area contains the following fields:

- Printer Type: HP LASER
- Description:  Lines / page: 60
- Initialize:
- 80 Col Start: /027E/027&l00/027(8U/027(s0p10h12v0s0b3T/027&l66/027&l2E/027&l7.8689C/027&l66F/027&k2G
- 132 Col Start: /027E/027&l00/027(0U/027(s0p16.66h8.5v0s0b0T/027&l66P/027&l2E/027&l7.8689C/027&l66F/027&k2G
- Bar Code Start:
- Bar Code End:
- Neg Line Feed:
- Reset:

**Printer Type.** Select your printer type from the list of predefined types. If your printer type is not in the list, use a similar printer type or define a new one.

To define a new printer type, you specify a series of programming sequences to control printer characteristics and behavior in the following situations:

- 80-character-width print jobs
- 132-character-width print jobs
- Barcode print jobs
- Hardware initialize and reset

Using control characters, you define how your printer performs such tasks as modifying fonts, changing page orientations, producing multiple copies, and so forth. Your printer manual is the best resource for control code definitions.

**Note** Without correct control codes, the related aspect of printer control will not work.

Use normal ASCII characters in the control fields. For nonprinting characters, also called control characters, use a slash and the three-digit ASCII number for the character. Table 4.1 lists characters frequently used in control sequences.

**Table 4.1**  
Control Characters

Control Character	ASCII
Backspace	/008
Tab	/009
Linefeed	/010
Form Feed	/012
Carriage Return	/013
Escape	/027

Default system data includes correct control sequences for some commonly used printers.

**Note** One of the default printers is terminal. Use terminal in a character interface and page in the QAD .NET UI.

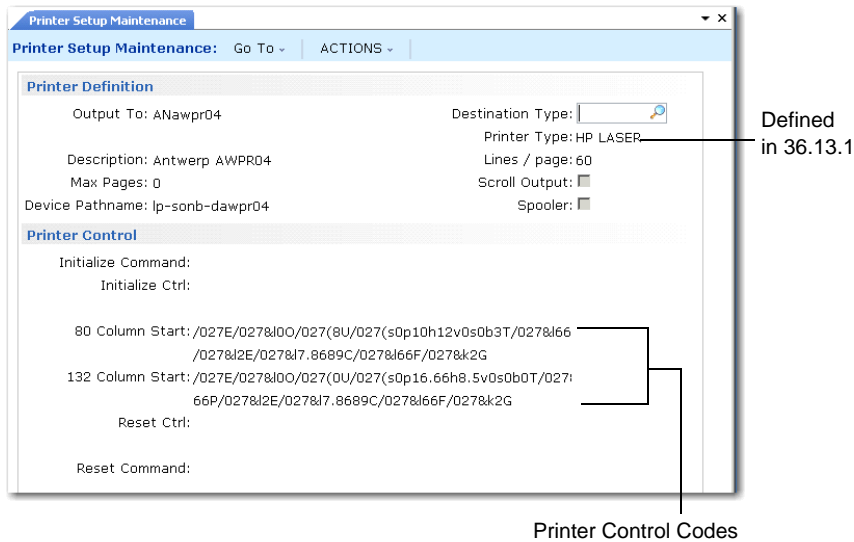
**Table 4.2**  
Sample Printer Control Codes

Code	Function
/X27E	Printer reset
/X27&l3A	Folio paper format
/X27&lXO	Portrait orientation
/X27&l1O	Landscape orientation
/X27&l1S	Long edge binding (prints on both sides)
/X27&l66F	Bottom margin is 66 lines from top
/X27(sXp16.67h8.5vXsXbXT	Pitch 16.67, height 8.5, default style, thickness, font
/X27&l7X89C	Adjusts vertical index in steps of 1/48 inch
/X27(sXp16.67hXs3b4X99T	Pitch 16.67, height default, bold, courier (4X99)

## Setting Up Printers

After you have defined printer types, use Printer Setup Maintenance (36.13.2) to set up printers and other output devices.

**Fig. 4.2**  
Printer Setup Maintenance (36.13.2)



**Output To.** Assign a unique name to each printer or other output device. This name displays in the Output field of reports and inquiries. The QAD demo databases use *printer* and *terminal* for the most commonly used printers. However, you can use any name.

You can set up more than one record for the same printer, as long as you use different names in Output To. For example, this lets you access the same printer from both character and Windows clients.

**Destination Type.** Enter the type of device represented by this printer definition. Valid values are:

- **Default.** This is a server printer, a terminal display, a Windows display, or output to page. In Language Detail Maintenance (36.4.2), this mnemonic is assigned to value 0 (zero).
- **EMail.** This printer definition sends the report output to an e-mail message. For this to work properly, you must have an e-mail system that accepts a command-line interface. The e-mail system must be set up in E-mail Definition Maintenance, and the User Maintenance record for each user must include an e-mail definition and e-mail address. In Language Detail Maintenance, this mnemonic is assigned to value 1. See “Building an E-Mail System Interface” on page 80.

**Printer Type.** Optionally enter a printer type defined in Printer Type Maintenance. If you specify a type, the characteristics assigned to that type are copied into this printer setup record. You can modify them as required.

**Description.** Enter a description of the output device. Describing the physical location of a printer can be helpful.

**Lines/Page.** Enter the maximum number of lines to appear on a page. If you set up a printer to accept a maximum of 6 pages at 72 lines to a page, the printer prints only the first 432 lines of output, exclusive of the trailer.

**Max Pages.** Enter the number of pages a device can accept. If zero, no page limit applies.

**Important** System administrators should use Printer Setup Maintenance (36.13.2) to set a page limit of 1000 on the Output to Page option for reports. If you output a report of more than 1000 pages to Page, the retrieval of the data puts a burden on client resources and can cause system instability.

**Note** If you try to print checks, forms, and similar items on a device with a maximum page limit, an error message is displayed.

**Scroll Output.** Select this option to have the system accept a maximum of 3,000. Otherwise, the Max Pages limit applies.

**Suppress Trailer.** Specify whether this device suppresses the last page of the program output report.

No: The output report includes the last page, which includes such report trailer information as the selection criteria.

Yes: The output report stops after the last line of report data. Report trailer information is not included.

**Device Pathname.** Specify the operating system command or path name that enables you to output to this printer. A device path name is normally not required for a terminal. However, if you are setting up a slave printer or a terminal window under X-windows, you may need to enter a path name. Table 4.3 lists examples of device path names.

**Table 4.3**  
Sample Device Path Names

Device Path Name	Operating System	Effect
//arnt01/supjet1	Windows	Prints to network printer, shared as supjet1 off the arnt01 print server.
printer	Windows	Prints to Windows captured default printer.
lp -d supjet1	UNIX	Passes UNIX -lp command to operating system, causing printing at destination supjet1. Spooler must be selected.

**Spooler.** Indicate if this is a spooled device. This field only applies to UNIX systems.

**Initialize Ctrl/Reset Ctrl.** A slave printer is one connected to a local PC printer port or the printer port of a dumb terminal. To transfer printer output to the proper port, you may need to specify control codes for these fields. The initialize control string passes output from the terminal to the print device. The last section of the Reset control string returns output to terminal. Set up control strings for each printer. In UNIX, the slave printer device path name is:

/device/tty

## Defining a Printer for Use with QAD .NET UI

If users generate reports from the QAD .NET UI and want to view them immediately, they should choose the Page output device rather than terminal. Output to terminal is not formatted to display correctly in a browser.

The Page output device should be defined with the following settings:

- Max pages is 0.
- Destination type and printer type are blank.
- Lines per page is 66.
- Scroll output is selected.
- Spooler is not selected.

## Setting Default Printers

Use Printer Default Maintenance (36.13.4) to assign default output devices to users. This is only the default; you can change it to any valid device when you run the program. You can apply a record to all users by entering an asterisk (\*) in the User ID field.

**Note** Default output devices apply only to reports; the default device for inquiries is always terminal.

You can specify devices for a user ID or a combination of user ID and menu selection. This can be useful for specialized tasks such as sending checks to a check printer; the same user can have different default output devices for different programs.

The default does not necessarily have to be a physical printer; you can also choose to send output to the terminal, page, a window (GUI only), or an e-mail recipient.

## Defining Document Formats

Some programs let you specify alternative formats for printed documents in addition to the system-defined default formats. For example, an Italian customer may require a different sales order layout than a US customer. In that case, you can specify a predefined alternate format in the Form Code field of Sales Order Print (7.1.3).

You do not use a menu-level program to define alternate document formats. Instead, you must create a Progress program to generate them. Use the following steps to do this.

- 1 Create a Progress program to format the document as required.
- 2 Name the new program file appropriately so it can be located by the print program. The file name is typically created by removing the first two characters of the print program name and appending a two-character form code.
- 3 Modify the applicable print function to consider the new form code as valid.

**Example** You create two new sales order formats, identified with form codes AA and 2. The program name for Sales Order Print is `sosorp05.p` and the default sales order layout is defined by `sorp0501.p`. Use program file `sorp05AA.p` to store sales order form code AA and program file `sorp0502.p` to store form code 2. Be sure to include the zero preceding the 2. Then, modify `sosorp05.p` to define the two new formats as valid.



# Batch Processing and Daemons

This section describes how to set up and use background processes, including batch jobs and daemons.

## ***Introduction to Batch Processes and Daemons* 96**

Explains the programs used by the Batch Processing/Daemon menu.

## ***Batch Processes* 96**

Explains how to define batch IDs, review batch jobs, process batch requests, and invoke batch processing from CIM.

## ***Daemons* 99**

Introduces daemon processes, and discusses daemon users, types of daemons, and daemon functions, including how to use the event, report, and XML daemons, queue views, queue correct functions, and queue delete functions. Also discusses running daemons on the command line.

## ***Integrating XML Documents* 128**

Explains how to plan XML integration and identify business components; discusses business component structures, tables and mandatory fields, component schema and sample files; describes how to create XML files, integrate multiple records in an XML document, and process the XML file.

## ***Bulk Data Load* 139**

Describes how to use Bulk Data Load to add many types of financial data to your QAD system at once by uploading multiple CSV files. Bulk Data Load is useful for setting up a QAD implementation, because it lets you import very large amounts of data efficiently.

## Introduction to Batch Processes and Daemons

The Batch Processing/Daemon (36.14) menu includes two types of programs:

- Programs for creating and monitoring batch requests. These functions let system administrators edit and process batch jobs from multiple domains without having to switch the current working domain associated with their user IDs.
- Programs for configuring and managing daemon processes that run in the background whenever your database is active.

## Batch Processes

A batch process is a group of processes run simultaneously. You can use batch functions to defer processing and report printing for reasons such as the following:

- A printer is busy or broken.
- Users want to be able to continue working without having to wait for lengthy reports to finish.
- Reports need to be run in a sequence, regardless of how they are submitted.
- You want to balance system load by running CPU-intensive programs when system load is low, perhaps at night.

**Note** Batch reporting for Financial reports is handled by the Report Daemon and .Net Report Service. See “Report Daemon” on page 120.

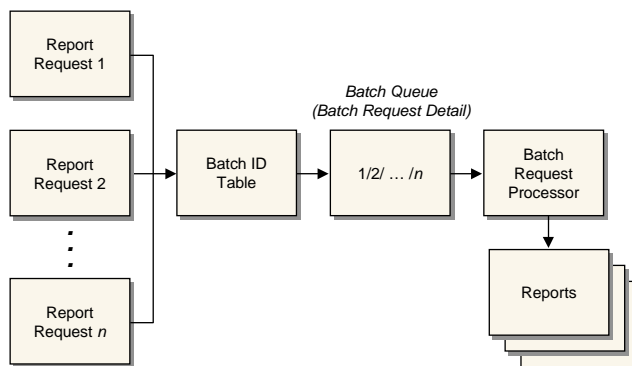
### Define Batch IDs

To set up a batch process, system administrators first create batch IDs in Batch ID Maintenance (36.14.1). Use ID names that are descriptive and easy to remember, such as Paycheck, Monthly, or After5. You also assign the batch a priority that determines when it will run. Requests with the highest priority are run first.

Users then submit reports or programs that can be run in batch mode and specify the batch ID.

**Note** Batch IDs are domain specific. You must set up a separate set of IDs for each domain. You can, however, manage batch processes from multiple domains in the batch processing programs.

**Fig. 5.1**  
Batch Processes



## Review Batch Jobs

Usually the system administrator reviews batch requests prior to batch processing. Use Batch Request Detail Maintenance (36.14.3) to view reports and programs submitted to any batch. You can eliminate duplicate or unnecessary requests, prioritize requests, and redirect output as needed.

You must specify the domain associated with the batch requests you want to modify. You must have access to any domain you specify in User Domain/Entity Access Maintain.

**Fig. 5.2**  
Batch Request Detail Maintenance (36.14.3)

As each request is executed, its status is updated to reflect whether it completed normally. Statuses include:

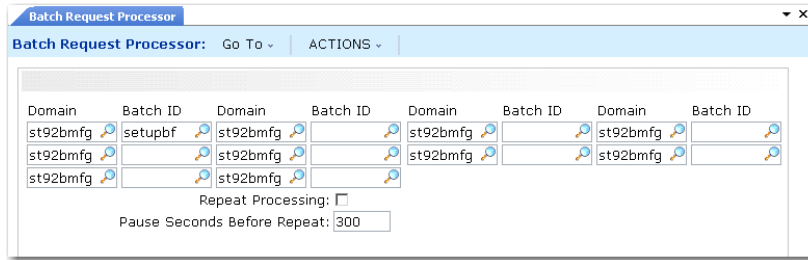
- Failed (incomplete)
- Complete
- Running

When a batch does not complete normally, use Batch Request Detail Maintenance (36.14.3) to select the Process field and restart Batch Request Processor.

## Process Batch Request

Use Batch Request Processor (36.14.13) to run reports and/or programs submitted by users with a batch ID. You can process up to 10 batch IDs in a single run. Each batch ID can be associated with a different domain. This lets you manage batch requests for multiple domains within one database without having to change your current working domain.

**Fig. 5.3**  
Batch Request Processor (36.14.13)



When you run a batch process, the system executes all items queued for a given batch ID in the requested order. You control the batch order by assigning a priority to each batch ID.

## Invoke Batch Processing from CIM

In UNIX or Windows, you can create a batch file that invokes batch processing. You can then schedule when to run the script of the batch file. The scheduling capability of the operating system lets you run the batch processing at a time that is most convenient for you.

**Note** This is especially important if you have a Unicode database with domains that have incompatible code pages. This lets you run batch jobs that bypass the restrictions on a character client session. See “Multiple Languages and Unicode” on page 46 for details about restrictions in a Unicode database.

To set up a batch script, follow these steps.

- 1 Prepare a file that anticipates all data entry to Batch Request Processor (36.14.13).

The file should use CIM format. The first line provides login information:

```
"<User_Name>" "<Password>" "<Login_Domain>"
"mgbatch.p"
"<Domain>" "<Batch_ID>"
-----
"<Is_Repeat>"
-
.
.
"Y"
```

In the script, `mgbatch.p` is the program name for Batch Request Processor. `Domain` and `Batch_ID` identify the batch requests to process. The line `Is_Repeat` indicates that requests for multiple domains can be included in the script. A hyphen (-) indicates to tab through a field; the two dots are exits, and Y confirms the exit from your session.

See Chapter 7, “CIM Interface,” on page 161 for more details on CIM load processing.

- 2 Create a `.p` file of following format. Replace `Input_File` with the path of the file that you prepared in the previous step.

**Note** If you are working in UNIX instead of Windows, the first statement in the following script is unnecessary.

```
Assign PROPATH = <Propath>.
Input From <Input_File>.
Output To <Output_File>.
```

```
Run mf.p.
Input Close.
Output Close.
```

- 3 Set up a batch file. The batch file is a `.sh` file that can be scheduled using the UNIX `crontab` command or a `.bat` file that, in Windows, you can add to Scheduled Tasks in Control Panel.

To set up the batch file, use the Progress command `mpro` (UNIX) or `prowin32.exe` (Windows) to invoke the `.p` program that you created in step 2.

- In UNIX, the `.sh` file has the following structure:

```
TERM = <Term>;
DLC = <DLC>;
PATH = <Path>;

PROPATH = <Propath>;

mpro <DB_Parameters> -p <Progress_Program> <Startup_Parameters>
```

- In Windows, the `.bat` file has the following structure:

```
SET DLC = <DLC>

SET PATH = <Path>

prowin32.exe <DB_Parameters> -p <Progress_Program> <Startup_Parameters>
```

The table describes the variables used in the scripts.

**Table 5.1**  
Variables in Batch File

Parameter	Description
<i>DLC</i>	Specify the value of the <i>DLC</i> system variable.
<i>PATH</i>	Specify the value of the <i>PATH</i> system variable.
<i>TERM</i>	For UNIX only, specify a terminal type.
<i>PROPATH</i>	Specify the value of the Progress <i>PROPATH</i> variable.
<i>DB_Parameters</i>	Specify the parameters to connect to the database. For more information, see Progress help.
<i>Progress Program</i>	Specify the path of the <code>.p</code> program that you created in the previous step.
<i>Startup Parameters</i>	Specify other parameters for <code>mpro</code> or <code>prowin32.exe</code> to start. For more information, see Progress help.  If you are using OpenEdge 10.1A or above, you can specify the database connection to support Unicode with the following setting: <ul style="list-style-type: none"> <li>• <code>-cpinternal utf-8</code></li> <li>• <code>-pcoll icu-uca</code></li> </ul> You need Unicode support if the batch processing you execute will access more than one domain in a database, and the domains store language data that have incompatible code pages.

## Daemons

Daemons are server-based processes that let you run background tasks. The user has no direct input with the daemon processes.

Daemon processes apply only to component-based functions. They can be run on the same application server as QAD Financials, or you can specify a different appserver for each daemon. You should define the appservers to be used for daemon processing during system implementation.

**Important** Some daemon processes must be running to ensure the integrity of your application. You should ensure that these processes are configured to start when the database is started.

## Overview of Daemon Processing

In general, tasks for the daemon are stored in a queue in a dedicated database table. The daemon regularly checks its queue for tasks and then processes them. If no more tasks remain in the queue, the daemon enters a period of inactivity known as sleep mode. After a predefined period, the daemon exits sleep mode and check its queue for new requests.

The behavior of each daemon and its request queue are controlled and monitored using specific maintenance programs. You can start multiple instances of a daemon if the workload requires this.

The system has the following daemons:

- Balance daemon
- Budget daemon
- Cube daemon
- Cross-Company daemon
- Event daemon
- History daemon
- Replication daemon
- Report daemon
- Scan daemon
- Time Out daemon
- XML daemon

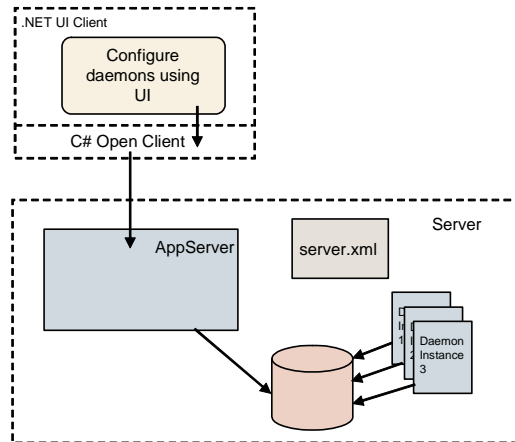
All daemons, except the XML daemon and Report daemon, share the same control activities. The XML daemon differs from the others in that it creates its own requests by importing files from a specific directory on the file system. Otherwise, the XML daemon behaves like the other daemons.

The Event daemon publishes Financials events as XML messages that can be exported to other application instances or external Financial applications using QXtend.

Requests to the Report daemon are handled by the .NET Report Service, which is a separate server installation. You also use the Report Service to stop and start the Report daemon, and can monitor Service activity using the daemon Monitor function.

The Replication daemon is only used during the creation of new domains to propagate shared set data.

**Fig. 5.4**  
Daemon Architecture



## Daemon User

Each daemon must log in to the system to perform its updates, and you specify the user login ID and password to associate with each daemon when you configure it. The recommended practice is to use the same user ID for all of the daemons, to make maintenance easier.

The user you specify must have access to all activities in Role Permissions Maintain and all domains and entities.

**Important** Whenever you create a new domain or entity, you should assign access to this system user. When you create a new domain and confirm it, the replication will fail if the Replication daemon user does not have access to the new domain.

## Types of Daemon

### Balance Daemon

The Balance daemon operates in a similar manner to the History daemon. It builds the supplier and customer balance and movement data and history files.

The Balance daemon updates the supplier and customer history tables each time a movement is created on an invoice.

**Note** If queue records are waiting to be processed by the Balance daemon, the supplier and customer balances may be inaccurate.

As with the History daemon, you can set a parameter in the Balance configuration file to periodically attempt to restart daemons that have stopped unexpectedly. For more information, see “Restarting Daemons Automatically” on page 103.

### Budget Daemon

The Budget daemon allocates postings and commitments to the appropriate budget topics. All postings are processed, including those in the transient and management layers.

Budgets are composed of budget topics, and each topic is linked to a level in the chart of accounts (COA) and to specific values for that COA level. The Budget daemon inspects all budget definition tables, and updates the actuals for the relevant budget topics.

The Budget daemon should be active when allocations are executed because the allocation functionality uses the same tables. The Budget daemon ensures that the most current values are available for an allocation run. For more information on allocations, see *QAD Financials User Guide*.

### Cross-Company Daemon

The Cross-Company daemon processes automatic cross-company postings that cannot be performed manually in the UI. The daemon is used to perform calculations and postings to spread the transaction load on the CPU.

The Cross-Company daemon handles transactions related to invoices and banking entries. These can occur in the following activities:

- Customer invoices and credit notes
- Supplier invoices and credit notes
- Banking entry
- Payment selection
- Payment documents
- Open item adjustment

The Cross-Company daemon processes transactions in the official layer only, and completes the linking fields in both the source and target posting line.

Posting occurs in the source entity using the Cross-Company Control account for the target entity. The system creates a request for the Cross-Company daemon, and posting and request creation occur within a single transaction. The daemon processes the request and creates the posting and the movement in the sub-ledger of the target entity.

### Cube Daemon

The Cube daemon builds data for report cubes used in Financial Report Writer, and is fed by the History daemon. Therefore, if the History daemon stops, the Cube daemon does not receive any queue requests.

You must stop the Cube daemon before you can rebuild report cubes in Financial Report Writer. You do not need to stop the History daemon; the Cube daemon catches up with missed updates when it restarts.

If the system finds errors during the update process (for example, missing exchange rates or missing COA cross references), these are logged in the Cube Build Log and you can view the errors using Cube Build Log Browse.

When the system finds an error in cube data, the cube is assigned the status Needs Rebuild and the daemon stops further updates for that cube. You must determine the root cause of the error and rebuild the cube using Cube Generation so that the cube status becomes Operational again.

For more information on Financial Report Writer, see *QAD Financials User Guide*.

### Event Daemon

The Event Daemon publishes Financials business events, such as record creation events, as XML messages. The Event daemon publishes the messages in its queue to a preconfigured destination, which can be a directory on a server or a QXtend server. Event publishing lets you export data updates to other Financials instances, without the need to extract the data from the database. See “Event Daemon” on page 117.

### History Daemon

The History daemon populates the database with condensed GL transaction data, and updates GL and SAF balances for each period. Detailed transaction data is accumulated in tables to increase performance in, for example, drill downs and reporting. All GL postings, including those in the transient and management layers, are processed.

The History daemon generates historical data grouped by a number of criteria, such as the posting period, the account, sub-account, project, cost center, period mark, daybook, and the entity used in the transactions.

The data fields in the history tables include the period movements, balances, and year-to-date values and are provided in the base, transaction, and management currencies. In addition, the quantity field is included.

#### Using the History Daemon to Perform Different Tasks

You can use the History daemon to perform tasks outside of its normal actions by customizing the empty method `BHistoryDaemonProcessor:PerformWorkItemSpecific()`.

First, create a request for the daemon with `SPECIFIC-ACTION` as the request reference. Then, when the daemon processes this request, it skips the normal actions and executes `BHistoryDaemonProcessor:PerformWorkItemSpecific()`.

#### Restarting Daemons Automatically

Sometimes, a daemon that should be running stops unexpectedly. This can cause a backlog of requests that affects other daemons, particularly the History and Balance daemons.

You can configure the History and Balance daemons to periodically attempt to restart stopped daemons. Each daemon has a configuration file of the form `<DaemonName>.config` in the `PROPATH` of the Financials appserver. Add the following property to the relevant configuration file:

```
AutoRecoverDaemons=TRUE
```

You can specify the interval at which an attempt to restart the daemons is made by including the following line in the relevant configuration file:

```
AutoRecoverDaemonsIntervalSec=900
```

The default value for this property is 1200 seconds, and the minimum value that you can set this property to is 60 seconds; lower values result in the default value being applied.

## Replication Daemon

The Replication daemon makes domain shared set data available to the operational functions, and replicates the data to the appropriate operational domain.

During implementation of the system and setup of the domains, you can continue to modify the data associated with a domain for as long as you require and then confirm the setup when you are satisfied that it meets your business requirements. Until the setup of a domain is confirmed, it is not available to your operational functions.

The availability of domain data to the operational functions is controlled by the Setup Complete field in the Domain function. When you select the Setup Complete field, the Replication daemon creates request queue records for each shared set. After the data has been reproduced, you cannot change the shared sets and base currency of the domain. In addition, you cannot link any of the entities linked to the domain to a different domain; the relationship is now permanent.

For more information on domains, see [QAD Financials User Guide](#).

The data made available to the operational functions includes daybooks; GL accounts, sub-accounts, and cost centers; suppliers, customers, and exchange rates.

The system creates a single Replication daemon request for a maximum of 90 records. Each request contains:

- The shared set code
- The ID of the primary entity of the domain
- A list with the IDs of the records that need to be replicated
- A priority that indicates the order in which each request should be processed

If any of records in a replication request fails to be replicated, all other records in the request fail also. Failed replication records remain in the daemon queue and have the status Processed-Error.

The user ID specified for the Replication Daemon login must have access to all domains and entities in the system.

**Important** You must grant the daemon user ID access to a new domain before confirmation or the replication process will fail.

## Report Daemon

Financial reports developed using Crystal Reports can be printed to screen or to a printer directly, or can be batch printed from a report queue. You can schedule batch reports, output them to files, or e-mail them to addresses or roles. The Report daemon processes these batch reporting requests. See “Report Daemon” on page 120.

## Scan Daemon

The Scan Daemon lets you configure the system to monitor a directory for documents to be attached to new records in the QAD application database. You configure the daemon by instructing it what to do when it finds a document.

**Note** In order to use the Scan daemon, you must enable workflow, since the scanned documents are associated with draft objects and sent to user inboxes for completion. See “Configuring Workflow” on page 159 for details.

For example, you can set up the daemon to monitor a directory for incoming supplier invoices. The Scan daemon processes documents located in entity-specific scan directories. The daemon creates a draft instance of the supplier invoice, attaches the scanned document, and sends the draft instance to the inbox of any user with access to the relevant domain and entity and a role with access to the Supplier Invoice Create activity. The original scanned documents are renamed in the scan directory to prevent a document from being processed multiple times.

Supplier invoice is the most common type of document to scan, but you can also use this feature to scan documents related to any components that support the save-as-draft feature. For example, you could scan new customer profiles and send them to the inbox of those responsible for creating customer records.

You can attach documents of any file type, but you should ensure that your users have the correct applications to open the file. Typical files to attach are .pdf, .doc, .txt, and .jpg.

The Configure activity for the Scan daemon includes an additional grid where you specify the scan directory associated with each entity. See “Configuring the Scan Daemon” on page 115 for details.

### Time Out Daemon

You can configure a user time-out setting defined in Security Control (36.3.24). This feature lets system administrators automatically terminate inactive user sessions, therefore reducing system load and improving performance for active users. Time out is defined as a number of minutes a logged in user can be inactive.

For more information on security settings, see *QAD Security and Controls User Guide*.

**Note** If you decide to implement this setting, it can result in loss of data if users have partially completed input in a program.

If you want to use the time-out feature, in addition to the setting in Security Control, you must ensure that the Time Out daemon is also running. This daemon ensures that the system is aware of component-based activities that have been started and resets the time-out period whenever a user initiates an activity.

If the daemon is not running, the system is only aware of the execution of standard programs and may terminate users running component activities.

### XML Daemon

The XML daemon processes external data in XML format, by parsing XML document headers and calling the relevant software component to process the document. See “XML Daemon” on page 123.

## Daemon Permissions

With the exception of the XML daemon, none of the daemons have any security requirements. Therefore, you can set them up without any specific permissions. First, create a role named daemon with no security rights. Then, create a user named daemon that has access to all entities and is linked to the role daemon in all entities.

The XML daemon is a special case because it can be used for many different activities. For example, an xml message to create a customer invoice means that the daemon user must have access to the activity Customer Invoice Create. Therefore, for the XML daemon, you must create a specific role, or roles, depending on what you are using the daemon to do.

## Daemon Functions

Use the following activities to maintain and control daemons:

- Configure
- Start
- Stop
- Clear Queue
- Monitor

**Note** Separate to this Monitor activity for each daemon, the Daemon Monitor menu option allows you to monitor all daemons from a single screen. The Daemon Monitor also allows you to view the log file and set debug levels for a daemon, and to start and stop all daemons at once. See “Monitoring Daemons Collectively” on page 113 for more information.

These activities are the same for all of the daemons, except the XML daemon, which is described on page 123, and the Report daemon, which is described on page 120. In addition, the Scan daemon has an extra grid, described on page 115.

Both the Configure and Monitor activities check the status of the daemon and correct it before displaying. For example, if the daemon status is set to Running but no daemon process is detected on the QAD Financials appserver, the status is reset to Inactive before the Configure or Monitor screens display.

**Note** You configure, clear queues, and monitor the Report daemon in the same way as for other daemons. However, the Report daemon is stopped and started from within the .Net Report Service.

## Configure

The Configure activity lets you configure maintenance information for the daemon, such as the login ID and password, in addition to the log file and start directory. For security reasons, you should use a dedicated daemon user name. The user name must have access to all domains and entities have role permissions to all component activities in the database.

**Note** The activities controlled by the daemon must be included in the list of activities for the role assigned to the daemon user name.

The Configure activity also lets you define the time interval before the daemon checks its queue for new requests, indicate whether to record processed items for audit purposes, and set the number of records that the daemon should process in each run.

**Fig. 5.5**  
Event Daemon, Configure (36.14.16.1.1)

The screenshot shows the 'Event Daemon Configure' window with the following fields and values:

Daemon Name	EventDaemon	Last Start Date	04/21/2008 08:47:30
# Instances	1	Last End Date	00:00:00
Interval (Sec)	10	Daemon Status	Running
Keep Processed Items	<input checked="" type="checkbox"/>	Running Processes	1
Number Treated in One Run	999,999		
Login ID for this Daemon	mfg		
Password for this Daemon			
Daemon Log File	\$ENVRROOT/logs/EventDaemon.log		
Daemon Start Directory	\$ENVRROOT/daemons/EventDaemon		
OS Command String	<DaemonExecutable>		
Appserver URL			

## Field Descriptions

*Daemon Name.* Displays the daemon name.

*# Instances.* Enter the maximum number of instances that can be started for this daemon. It is possible to enter 0, meaning that the daemon is not configured for use in the system setup.

*Interval (Sec).* Specify the time interval in seconds before the daemon checks its queue for new requests.

*Keep Processed Items.* Select the field to record processed items for audit purposes. When you clear the field, the system deletes all successfully processed requests from the Monitor screen. See “Monitor” on page 109.

**Note** It is recommended to clear this field for any daemons that process a high number of requests so that you can easily see requests processed with errors.

*Number Treated in One Run.* Specify the number of requests that the daemon should process in a single run. Note that during a run, the daemon does not react to Stop commands. If you set this number too high, the response time to a Stop command increases accordingly.

*Login ID for this Daemon.* Specify the ID of a valid active user that is assigned a role that grants permission to all activities and access to all domains and entities. To ensure proper security is enforced, the daemon process accesses the database by logging in with this name.

**Note** The login details you specify are used by the Report daemon to determine the From address when you e-mail a report.

*Password for this Daemon.* Specify the password for the user ID in the previous field.

**Important** If the password of this user is changed in User Maintenance, the change is not automatically reflected here. You must ensure that the passwords are updated in both places, or the Daemon process will fail on login.

*Daemon Log File.* Specify the full path of the log file in which the system records the daemon’s actions.

By default, the system uses the Environment Root variable `$ENVROOT` to specify the location of the daemon log file. The `$ENVROOT` variable takes its value from the `serverXML` file for the application environment, and ensures that the financial database can be copied between environments without the need to reconfigure the daemons.

The log file path by default is:

```
$ENVROOT/logs/<daemon name>.log
```

You do not normally need to modify this default.

To troubleshoot daemon activity, you can modify how messages are generated to the daemon log file by setting the debug level in the daemon configuration file. Each daemon has a configuration file of the form `<DaemonName>.config` in the `PROPATH` of the Financials appserver.

**Example** To increase the message detail for the History daemon, modify the debug level in `HistoryDaemon.config`.

**Daemon Start Directory.** Specify the directory on the file system where the physical daemon process is started. Progress keeps its internal and temporary files related to the daemon process in this location.

The system also uses the Environment Root variable `$ENVROOT` to specify the location of the daemon start directory.

The start directory path by default is:

```
$ENVROOT/daemons/<daemon name>/
```

You do not normally need to modify this default.

**OS Command String.** Enter the physical command used to run an instance of the daemon. A part of this command string is determined by the application itself, and is referenced by using `<DaemonExecutable>`, and differs between operating systems. You can add parameters to the command, but should include the `<DaemonExecutable>` tag to refer to the actual executable.

**Appserver URL.** Enter the connection URL for the application server on which this daemon is to be run. You can optionally use a different server than the main application server.

**Important** It is recommended that you define a different appserver connection for the Report daemon. This ensures that the batch processing of report requests does not have an impact on overall server performance.

**Start Date of Last Daemon Run.** This field displays the last time the daemon started.

**End Date of Last Daemon Run.** This field displays the last time the daemon stopped.

**Daemon Status.** This field displays the daemon status. Valid values are Inactive, Running, and Stopping. The Start and Stop activities control the status changes.

**Number of Running Processes for this Date.** Displays the number of instances of the daemon that are currently running. This value is zero when the daemon is inactive.

## Start

The Start activity starts the daemon. The system displays a message that indicates that the daemon has started successfully.

## Stop

The Stop activity stops the daemon.

The daemon stops after it completes its current task. Depending on the type of daemon and the amount of time it takes to complete an operation, some time may pass before the daemon detects the stop request and shuts down.

The system displays a message that indicates that the daemon has stopped successfully.

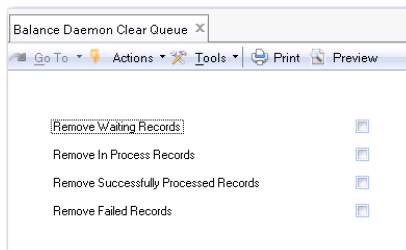
**Note** The Start and Stop activities are not available for the Report daemon, which is managed by the .Net Report Service.

## Clear Queue

Use the Clear Queue menu option to manage daemon queue requests. The records you select are immediately removed from the daemon queue.

**Important** Only qualified and trained personnel should clear queues because this action can potentially destroy valuable information or interfere with critical application processes.

**Fig. 5.6**  
XML Daemon Clear Queue (36.14.16.6.2)



## Field Descriptions

*Remove Waiting Records.* Select the field to remove records that are waiting to be processed from the daemon queue.

*Remove in Process Records.* Select the field to remove in-process records from the daemon queue.

*Remove Successfully Processed Records.* Select the field to remove successfully processed records from the daemon queue.

*Remove Failed Records.* Select the field to remove failed records from the daemon queue.

## Monitor

There are two methods of monitoring daemons:

- Individually, using the Monitor menu option for the particular daemon.
- Collectively, using Daemon Monitor (36.14.16.25).

## Monitoring Daemons Individually

The Monitor screen for a particular daemon lets you view the start and stop dates for the daemon and the requests that are processed, waiting, in progress, or incorrectly processed.

To access the monitor screen for a particular daemon, launch <daemon name> Daemon Monitor, where <daemon name> is the daemon name. Figure 5.7 displays the Event Daemon Monitor screen. The screen is composed of a header area and two grids.

The header area contains fields that display the daemon name, the start and end times, and the daemon status. The header also contains fields that let you choose the type of requests to include in the view.

The center grid of the Monitor displays:

- The start and end time of the request currently processing.
- A description of the request.
- The status of the request. The valid values are PROCESSED-OK, PROCESSED-ERR, WAITING, and IN-PROCESS.

Additionally, if you set a specific start date and time for the request, the center grid also displays this data. It is only possible to set a specific request date and time for the XML daemon.

The lower grid displays the error information for each request line, if any.

The view does not store correctly processed records after the next refresh unless the Keep Processed Items field is selected in the Configure screen.

**Fig. 5.7**  
Event Daemon Monitor (36.14.16.1.3)

Event Daemon Monitor

Go To Actions Tools Print Preview

Daemon Name: EventDaemon  
 Interval (Sec): 20  
 Include Waiting:   
 Include In Process:   
 Appserver URL: AppServer://coli49.18265/QADFin\_AS  
 Daemon Start Directory: /qad/local/sandbox/team/fin93/build/work/daemons/EVENTDAEMON  
 Last Start Date (UTC): 10/07/2014 00:58:30  
 Last End Date (UTC): 10/07/2014 01:00:35  
 Daemon Status: Inactive  
 Running Processes: 0  
 # Waiting Requests: 862

Daemon Request Start Date	Start Time	Ref Description	Daemon Request Status
10/07/2014	00:58:55	Event for component Domain (BDomain)	PROCESSED-ERR
10/07/2014	00:58:54	Event for component Business Relation (BBusinessRelation)	PROCESSED-ERR
10/07/2014	00:58:54	Event for component Customer Invoice (BDInvoice)	PROCESSED-ERR
10/07/2014	00:58:54	Event for component Customer Invoice (BDInvoice)	PROCESSED-ERR
10/07/2014	00:58:54	Event for component Customer Invoice (BDInvoice)	PROCESSED-ERR
10/07/2014	00:58:54	Event for component Customer Invoice (BDInvoice)	PROCESSED-ERR
10/07/2014	00:58:54	Event for component Customer Invoice (BDInvoice)	PROCESSED-ERR
10/07/2014	00:58:54	Event for component Domain Property (BDomainProperty)	PROCESSED-ERR
10/07/2014	00:58:52	Event for component Customer Invoice (BDInvoice)	PROCESSED-ERR

Refresh Auto Refresh Close

**Note** If a request does not process successfully, then the daemon automatically resubmits the request after a delay of 30 seconds. This resubmission can happen only three times per request. If the request is not processed successfully after three resubmissions, it will be marked as PROCESSED-ERR.

## Field Descriptions

*Daemon Name.* Displays the daemon name.

*Interval (Sec).* Displays the time interval in seconds before the daemon checks its queue for new requests. You can update this value using the Configure screen.

*Include Waiting.* Select the field to include waiting requests in the view.

*Include Successfully Processed.* Select the field to include correctly processed requests in the view.

*Include in Process.* Select the field to include requests that are in progress in the view.

*Include Failed.* Select this field to include incorrectly processed requests in the view.

*Last Start Date (UTC).* This field displays the last time the daemon started.

*Last End Date (UTC).* This field displays the last time the daemon stopped.

*Daemon Status.* This field displays the daemon status. The valid values are Inactive, Running, Starting, and Stopping. The Start and Stop activities control the status changes.

*Running Processes.* This field displays the number of instances of the daemon that are currently running. This value is 0 when the daemon is inactive.

*Appserver URL.* This field displays the URL of the appserver on which this daemon is running. The field is blank when the daemon is running on the main appserver.

*Daemon Start Directory.* This field displays the location of the daemon start directory, which the system retrieves from the daemon configuration.

*# Waiting Requests/Number of waiting queues.* Displays the number of records in the daemon queue that have the status Waiting.

*Number of queue records.* Displays the number of records in the daemon queue. This field displays in the Balance, Budget, Cross-Company, Cube, History, and Replication Daemon Monitor screens only.

## Status Grid

*Daemon Request Start Date.* This field displays the date on which the daemon request was submitted.

*Start Time.* This field displays the time at which the daemon request was submitted.

*Ref Description.* This field displays an abbreviated description of the request type.

*Ref.* Request number.

*Daemon Request Status.* This field displays the status of the request. The possible statuses are: WAITING, IN-PROCESS, PROCESSED-OK, and PROCESSED-ERR.

*Daemon Request End Date.* This field displays the date on which the request was processed.

*End Time.* This field displays the time at which the daemon finished processing the request.

*Locked Process.* This field displays the ID of the process that is running the request. Some daemons can be run several times at once. Every time a daemon is started, a new physical Progress process is started.

*Daemon Request Log.* This field displays the date and time of the error together with the type of error.

*Sequence.* This field displays the order in which the requests should be handled.

*Requested Start Date of Daemon.* This field displays the requested start date for the daemon request.

If no start date is requested, the request will be processed as soon as possible.

*Req Start Time.* This field displays the requested start time for the daemon request.

If no requested start time or start date is specified, the daemon processes the request immediately. If no start time is specified, but the start date is, the request will be processed as early as possible on the requested date.

The Monitor screen for the Report daemon has two additional fields:

*Socket Port.* This field displays the server port on which the .Net Report Service is listening for requests.

*Socket Server.* This field displays the server on which the .Net Report Service is running.

These fields display values when the .Net report Service is running successfully. If the .Net Report Service is interrupted, these fields are blank. Errors in the .Net Report Service are displayed as Windows log events on the server on which the service is installed.

**Note** To improve response times, the Monitor screen center grid for the History daemon differs from that of the other daemons. You can choose the default behavior, where one line appears in the grid for each request, or you can display multiple requests in a single line. To display multiple requests in a single line, set the Number Treated in One Run property of the History daemon configuration file to 999999. The CT log file for these grid lines contains less information than the CT log file for grid lines that appear in this screen during the default screen behavior.

#### Error Grid

*Daemon Request Log.* Displays the date and time of the error together with the type of error.

*Field Label.* Displays the label of the field that initiated the error.

*Field Name.* Displays the name of the field that initiated the error.

*Field Value.* Displays the value in the field that initiated the error.

*Accompanying Error Message.* Displays the message associated with the error.

*Error Severity.* Displays the severity level of the error.

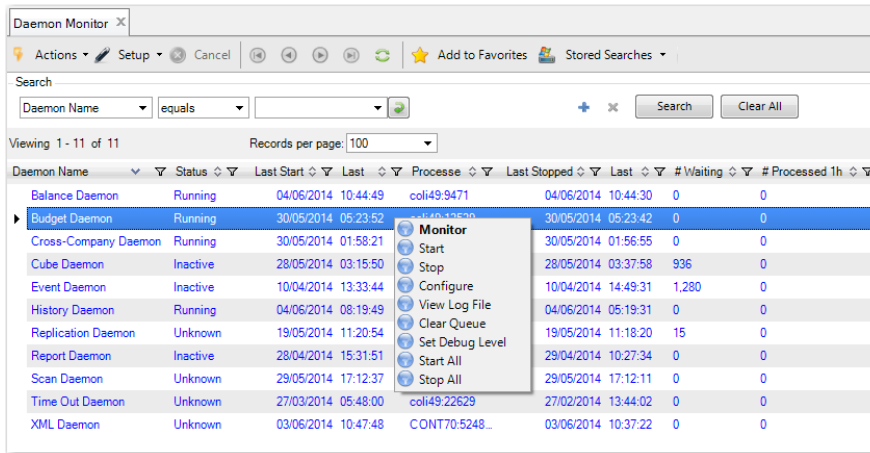
*Error Type.* Displays E for error, I for informational, and W for warning.

## Monitoring Daemons Collectively

The Daemon Monitor screen (36.14.16.25) lets you monitor all daemons at once.

The screen is a browse with search criteria and a results grid. When the menu option opens, all daemons are displayed by default; use the search criteria to refine the results.

**Fig. 5.8**  
Daemon Monitor (36.14.16.25)



## Search Criteria

By default, one search field displays. You can add more fields and use the drop-down menu in the search field to specify further criteria. The search criteria correspond to the column headings in the results grid.

## Results Grid Columns

**Daemon Name, Name, Status.** The translated name, name, and status of the daemon. Possible statuses are Inactive, Starting, Running, and Stopped.

**Last Started, Last Started (UTC), Last Stopped, Last Stopped (UTC).** The date and time that the daemon was most recently started and stopped.

**Last Started By, Last Stopped By.** The user who most recently started and stopped the daemon. If the daemon started or stopped as a result of an operating system script, then this information appears in the column as <system>.

**# Instances.** The number of instances of the daemon that are currently running. This value is zero when the daemon is inactive. This column corresponds to the Daemon Monitor search criteria # Instances and Running Processes.

**Processes.** For running processes, this column displays the name of the server that the daemon process is running on and the process ID. If multiple processes are running for the daemon, then this column displays a list of server names and process IDs.

**# Failed, # Waiting, # Processed 1h, # Processed 24h.** These columns display the number of instances of the daemon that have failed, are currently waiting in the daemon queue, were processed within the last hour, and were processed within the last 24 hours, respectively.

**Daemon Log File.** Displays the path to the log file for the daemon.

*Daemon Log Level.* This column displays information about the debugging options that are activated for the daemon. You can set these options in the Daemon - Set Debug Level screen, which is accessed by right-clicking a row in the status grid and choosing Set Debug Level.

The value of Daemon Log Level is initially 0, and increases by 1 when the first field in the Daemon - Set Debug Level screen is selected. It increases by 2 when the second field is selected, by 4 when the third field is selected, by 8 when the fourth field is selected, and by 16 when the fifth field is selected. For example, when the first and fourth fields in the Daemon - Set Debug Level screen are selected, then Daemon Log Level is 9.

*Daemon Start Directory.* The location of the daemon start directory, which the system retrieves from the daemon configuration.

*Daemon Login.* The user ID that the daemon used when logging in.

*OS Command String.* This column corresponds to the OS Command String field in the Configure screen for the daemon.

*No in One Run.* The value of the Number Treated in One Run field in the Configure screen for the daemon.

*Keep OK.* This column displays yes when the Keep Processed Items field in the Configure screen for the daemon is selected. Otherwise, this field displays no.

*Interval.* The time interval in seconds before the daemon checks its queue for new requests. You can update this value using the Configure screen.

*Appserver URL.* This column displays the URL of the appserver on which this daemon is running. The field is blank when the daemon is running on the main appserver.

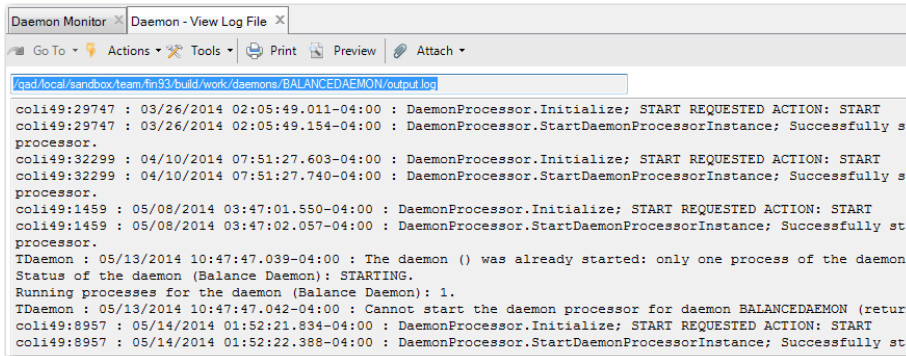
To perform an activity on a daemon, select the daemon in the grid and right-click to see the following options:

- Monitor
- Start
- Stop
- Configure
- View Log File
- Clear Queue
- Set Debug Level
- Start All
- Stop All

The Monitor, Start, Stop, Configure, and Clear Queue activities are described earlier in this section, Daemon Functions.

The View Log File option displays the log file for the selected daemon. For more information on the log file, see “View CT Logfile” on page 153.

**Fig. 5.9**  
View Log File



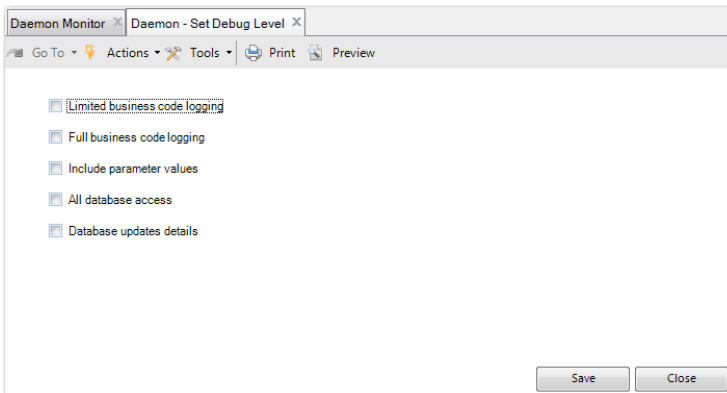
```

/qad/local/sandbox/team/fin93/build/work/daemons/BALANCEDAEMON/output.log
colli49:29747 : 03/26/2014 02:05:49.011-04:00 : DaemonProcessor.Initialize; START REQUESTED ACTION: START
colli49:29747 : 03/26/2014 02:05:49.154-04:00 : DaemonProcessor.StartDaemonProcessorInstance; Successfully s
processor.
colli49:32299 : 04/10/2014 07:51:27.603-04:00 : DaemonProcessor.Initialize; START REQUESTED ACTION: START
colli49:32299 : 04/10/2014 07:51:27.740-04:00 : DaemonProcessor.StartDaemonProcessorInstance; Successfully s
processor.
colli49:1459 : 05/08/2014 03:47:01.550-04:00 : DaemonProcessor.Initialize; START REQUESTED ACTION: START
colli49:1459 : 05/08/2014 03:47:02.057-04:00 : DaemonProcessor.StartDaemonProcessorInstance; Successfully st
processor.
TDaemon : 05/13/2014 10:47:47.039-04:00 : The daemon () was already started: only one process of the daemon
Status of the daemon (Balance Daemon): STARTING.
Running processes for the daemon (Balance Daemon): 1.
TDaemon : 05/13/2014 10:47:47.042-04:00 : Cannot start the daemon processor for daemon BALANCEDAEMON (return
colli49:8957 : 05/14/2014 01:52:21.834-04:00 : DaemonProcessor.Initialize; START REQUESTED ACTION: START
colli49:8957 : 05/14/2014 01:52:22.388-04:00 : DaemonProcessor.StartDaemonProcessorInstance; Successfully st

```

The Set Debug Level option lets you state the level of CT-logging that you want for the daemon. Selecting this option displays the Daemon - Set Debug Level screen. This screen is similar to the Set Debug Level screen described in “Set Debug Level” on page 151, but it contains an extra Database updates details option.

**Fig. 5.10**  
Daemon - Set Debug Level



## Configuring the Scan Daemon

The Scan Daemon Configure activity contains an additional grid for specifying the business component to be associated with a scanned document, the directory the daemon should monitor for documents, and the entity the scanned documents should be associated with.

**Fig. 5.11**  
Scan Daemon, Configure (36.14.16.4.1)

Location on The File	Component Code	Entity Code	Component Label	Entity Desc
▶ /qad/migpro/93tb	BCInvoice	2000	Supplier Invoice	Test Holding

## Field Descriptions

**Component Code.** Choose the name of the business component that the scanned document should be associated with. You can select only components that support the Save as Draft feature. Currently, this includes the following components:

- Banking Entry
- Business Relation
- Customer
- Customer Finance Charge
- Customer Invoice
- Journal Entry
- Petty Cash
- Supplier Invoice
- Supplier

**Example** You specify BCInvoice, the technical name for a supplier invoice. The Scan daemon runs the Supplier Invoice Create activity when it detects a document to scan.

Documents for each scanned component must be located in a separate directory. The component description displays in the Component Label column.

**Location on The File System.** Enter the full path to the directory on the Financials appserver where documents to be scanned and associated with the specified component are located.

**Important** Make sure the directory is on the correct server or it will not be found.

**Entity Code.** Specify the entity associated with the scanned documents.

## Event Daemon

The Event daemon processes Financials business events and publishes them to a defined destination. The system publishes events to a directory on the application server or to the QXtend Server for replication to other Financials instances or to third-party financial applications.

A business event in this case can be any modification to a Financials business object, such as an update to customer or supplier base data. By publishing the event, the system ensures that the update is replicated to other instances and so eliminates the need to extract the data directly from the database. The event consists of complete object data with context information that is published in XML format.

The Financials application uses a buffer queue within the running transaction to prepare messages before they are sent out. This ensures that no events are lost during system down-time and that no disruption of service occurs. Events are then published in XML format using a daemon process which routes the message to the specified destination.

Event publishing has three components:

- Event Destination

Create an Event Destination to define the name of the event and the type and details of the server connections.

- Event Configuration

Use Event Configuration to activate the publishing mechanism, configure which components and status transitions will trigger events—for example, supplier invoice creation—and indicate the destination queue of the event.

- Event Daemon

The Event daemon processes the events in its queue and displays the event message status.

## Event Destination

Use Event Destination Create (36.14.16.14.1) to define the name of the event and the type of messages it will contain. When you are using QXtend to export the events, you specify the connection to the appserver instance of QXtend Out (QXO) as the destination.

**Fig. 5.12**  
Event Destination Create

## Field Descriptions

*Destination Name.* Specify a destination name (maximum of 40 characters).

*Destination Type.* Select a destination type:

Direct Appserver. The events are published to an application server. When you select this type, the Directory field becomes unavailable.

To Directory. The events are published to a server directory.

*Appserver Connection.* Specify an application server connection. The protocol for the server path is:

```
appserver://<hostname>:<nameserver port>/<application service name>
```

The default nameserver port for a daemon running on the main application server is 5162.

*Appserver Procedure.* Specify a procedure to be applied to the event.

This is the procedure that is called on the appserver. For QXO (QXtend Out) this typically is `qad/qra/si/RPCRequestService.p`

*Directory.* Specify a server directory. This field is available when you select a To Directory destination type.

## Event Configuration

Use Event Configuration Create (36.14.16.15.1) to perform the following activities:

- Activate the publishing mechanism.
- Configure which components and status transitions will trigger events; for example, an update to Supplier base data.
- Select the destination of the event.

**Fig. 5.13**  
Event Configuration Create

## Field Descriptions

*Component Label.* Choose the business component that will trigger an event.

*Publish Any Update.* Select this field if any type of update to the business component is to trigger an event. Selecting this field makes the Object Status field unavailable.

*Object Status.* Choose the object status of the business component upon which the system will trigger an event.

*Destination Name.* Choose the name of a queue to which the event will be sent.

*Lock Object.* Select the field to lock the object for update after it has been published.

*Active.* Indicate if this is an active record.

*Header Only.* Select this field to publish event header details only.

*Suppress Empty Fields.* Select this field to exclude empty database fields from event publishing.

*Suppress Fields with Default Value.* Select this field to suppress all fields that contain the default value for that field as defined in the dataset.

If the default value of a numeric field is zero, all zero values are removed. If the default value of a Boolean field is False, all False values are removed. If the default value of a field is not null, fields with null values are not removed.

## Force Publish

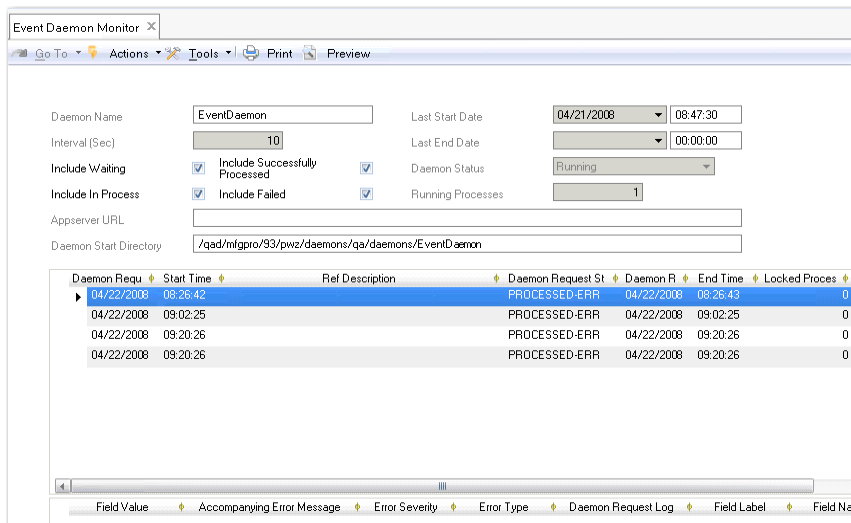
The Force Publish option is a right-click feature available on Enterprise Financials browses, which publishes a business event for the selected record. By publishing the event, the system ensures that the update is passed to the QXtend Outbound database and replicated to other instances of Financials or third-party applications. This facility eliminates the need for the other applications to extract the data directly from the Financials database.

In order to publish an event for a component, you must first define an event for the component using Event Configuration Create (36.14.16.15.1). In Event Configuration Create, you select the Publish Any Update field to ensure that all data updates for the business object for which you defined the event are published to QXtend.

## Event Daemon

The Event daemon reads event messages in its queue, and processes them according to the event configuration. You configure and monitor the Event daemon in the same way as other daemons.

**Fig. 5.14**  
Event Daemon Monitor



## Report Daemon

You can output a report directly to screen, in which case the system retrieves the report template and processes the report on the application client.

You can also:

- Schedule the report to be processed (printed, mailed or saved) at a later date.
- Schedule the report to be pre-processed at predefined intervals (daily, weekly, monthly, or yearly).
- Save the report in file format.
- E-mail the report to systems users or roles.
- Combine some or all of these options.

**Note** You select these options in the server output processing section of the report screen. For more information on generating reports, see [QAD Financials User Guide](#).

When you select one or all of these options, the report request is sent to the report request queue and is then handled as a server-side activity by the Report daemon.

The Report daemon handles all batch report requests for reports developed using Crystal Reports, including scheduled reports, e-mailed reports, and reports to be saved to file format or sent to a printer. The Report daemon is managed by the .Net Report Service, which is installed as an additional service on the application server.

The Report daemon:

- Monitors the report request queue
- Calls the .Net Report Service and passes the report details
- Receives the result of the report and issues a confirmation that the report has been successfully generated

## .Net Report Service

The .Net Report Service is responsible for starting, monitoring, and when necessary, restarting the Report daemon.

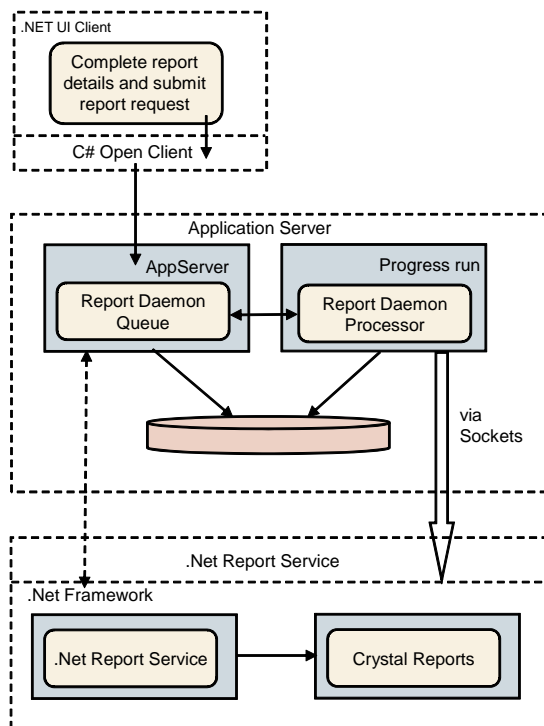
The .Net Report Service communicates with the Report daemon through the server socket port defined during the service configuration. Once the daemon is started, the report service:

- Runs the report business logic and resolves the e-mail addresses from roles and user names
- Retrieves a list of printers installed on the server and passes this list to the appserver for report printing
- Checks that the report templates stored on the server are up-to-date
- Updates the server socket port and socket host information on the Report Daemon monitor screen

When a report request is received from the Report daemon, the Report Service then:

- Passes the request details and report template to Crystal Reports
- Executes the report options by generating the report at the scheduled time, saving the report as a file, printing the report on a local printer, or e-mailing the report to a user or role
- Sends a confirmation request or error message to the daemon
- Receives a confirmation from the daemon and updates the daemon report log accordingly

**Fig. 5.15**  
Report Daemon Architecture



## Configuring and Monitoring the .Net Report Service

The .Net Report Service is configured by defining service settings in the QAD.CBFReportingService.exe.config file, which is located in the service installation directory.

Define the following settings in the <applicationSettings> section of the file:

- The SMTP Server for e-mailing reports
- The folder in which to save reports in file format
- The check interval in seconds for the report daemon
- The TCP socket port on which the service listens for report requests
- The user login ID and password for the service—normally your application login and password

### Example

```
<?xml version="1.0" encoding="utf-8" ?>
<configuration>
  <configSections>
    <section name="qad.appserver" type="QAD.AppServer.ASConfigHandler, QAD.AppServer"
  />
    <sectionGroup name="applicationSettings" type=
"System.Configuration.ApplicationSettingsGroup, System, Version=2.0.0.0, Culture=
neutral, PublicKeyToken=b77a5c561934e089" >
      <section name="QAD.CBFReportingService.Properties.Settings" type=
"System.Configuration.ClientSettingsSection, System, Version=2.0.0.0, Culture=neutral,
PublicKeyToken=b77a5c561934e089" requirePermission="false" />
    </sectionGroup>
  </configSections>
  <qad.appserver url="appserver://localhost:5162/devcbf93ui">
</qad.appserver>
  <applicationSettings>
    <QAD.CBFReportingService.Properties.Settings>
      <setting name="SMTPServer" serializeAs="String">
        <value>server01.company.com</value>
      </setting>
      <setting name="ReportFolder" serializeAs="String">
        <value>reports</value>
      </setting>
      <setting name="DaemonCheckInterval" serializeAs="String">
        <value>5000</value>
      </setting>
      <setting name="TCPPort" serializeAs="String">
        <value>4331</value>
      </setting>
      <setting name="LoginUsr" serializeAs="String">
        <value>user</value>
      </setting>
      <setting name="LoginPasswd" serializeAs="String">
        <value>password</value>
      </setting>
    </QAD.CBFReportingService.Properties.Settings>
  </applicationSettings>
</configuration>
```

The .Net Report Service is automatically started when you log in to the application.

The service can also be started with an alternative configuration file location, using the -configfile configfilename startup option.

## Errors in Report Processing

The Report Daemon monitor lists the report requests and status, and indicates if a report has not been processed correctly.

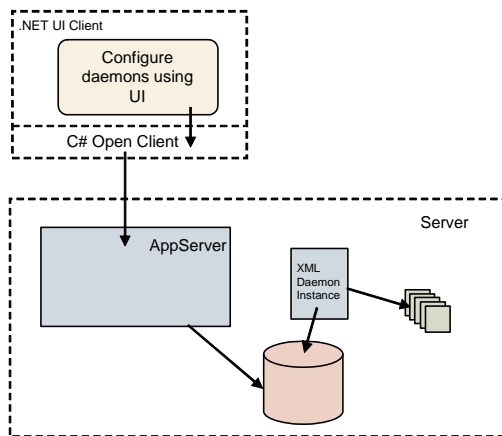
Processing error details are displayed on the .Net Report Service monitor screen. This monitor is launched using the `QAD.CBFReportingServiceMonitor.exe` file, which is contained in the .Net Report service installation folder.

## XML Daemon

The XML daemon processes external data in the form of XML files; for example, invoices are received in electronic form from a supplier. You store the files in a specific directory on the server and the daemon reads and processes them.

The XML daemon differs from the other daemons in that it creates its own requests.

**Fig. 5.16**  
XML Daemon Architecture



The daemon parses the header of an XML document and decides which software component to call to process the data. It then creates the appropriate request. The daemon reads each XML file once.

The XML daemon processes one supplier invoice for each XML file. If you attempt to use the XML daemon to process an XML file with two or more invoices, the system displays an error message.

The XML daemon can process XML files only. You must convert other text formats to XML according to the QAD-defined XSDs before importing them.

You can generate well-formed schema as a starting point for entering your own data by accessing the program that creates a component and selecting Properties from the component menu. The Properties dialog includes a Dump XML button that lets you generate schema to a designated directory.

**Important** The XML daemon can process a maximum of 500 XML files in one iteration.

## XML Daemon Actions

The XML daemon reads each XML file to determine what action it must take and how it should handle invalid data.

The XML daemon supports the following activities:

*Save.* The daemon validates the object and tries to save it. If the validation returns an error, the daemon does not save the object. You can use the Monitor screen to view the error message.

When using the Save action, XML files can contain data for multiple objects.

*Save/Create Draft.* This activity is similar to Save. However, if the validation returns an error, the XML daemon saves the object as a draft, without validation. In both cases, the queue entry is marked as processed correctly. You can use the Monitor screen to view the status.

When using the Save/Create Draft action, XML files cannot contain data for multiple objects.

*Create Draft.* The XML daemon does not validate data, and saves the objects as drafts.

When using the Create Draft action, XML files cannot contain data for multiple objects.

*Validate.* The XML daemon validates the objects and displays the results in the Monitor screen. It does not save data. When the input data is incorrect, the daemon displays the error and marks the queue entry as processed with errors.

When using the Validate action, XML files can contain data for multiple objects.

**Note** For the Create Draft feature to work, the object being created must support Save as Draft. Only a subset of business components can be saved as drafts: Banking Entry, Business Relation, Customer, Customer Finance Charge, Customer Invoice, Journal Entry, Petty Cash, Supplier, Supplier Invoice. Also the use of drafts must be enabled in System Settings.

Use the Action to be Performed field in the Daemon Configure screen to specify the next action for the daemon to perform.

The action applies to all XML files and overrules the action defined in the file if you select the Override XML Action field in the XML Daemon, Configure screen.

## Configure

The XML Daemon Configure screen lets you configure the XML daemon and differs from the Maintain screen of the other daemons.

The settings in XML Daemon Configure instruct the daemon to convert an XML file into a daemon request and how to process it. Only the settings that are unique to the XML Daemon are described here; the others are the same as the general settings discussed with the History Daemon Configure screen on page 107.

**Fig. 5.17**  
XML Daemon, Configure (36.14.16.6.1)

## Field Descriptions

*Input Directory for XML Files.* Specify the directory that the daemon scans for XML files.

**Note** You must specify an input directory to enable the daemon process.

*Action to be Performed.* Optionally, choose the action that the XML daemon must perform on the data in the XML file. If not specified, the action is read from the XML file.

*Override XML Action.* Select this field to overrule the action specified in the XML file with the action defined in the Action to be Performed field.

*Override Originator Action.* Select the field to overrule the action based on the originator and according to the rules defined in the grid.

The Originator field is part of the header section of the XML file and indicates the origin of the file; for example, a source application or external party.

*Originator.* Specify the originator for which to perform the overrule action.

*Activity.* Select the default activity to perform on loaded XML files. The options are:

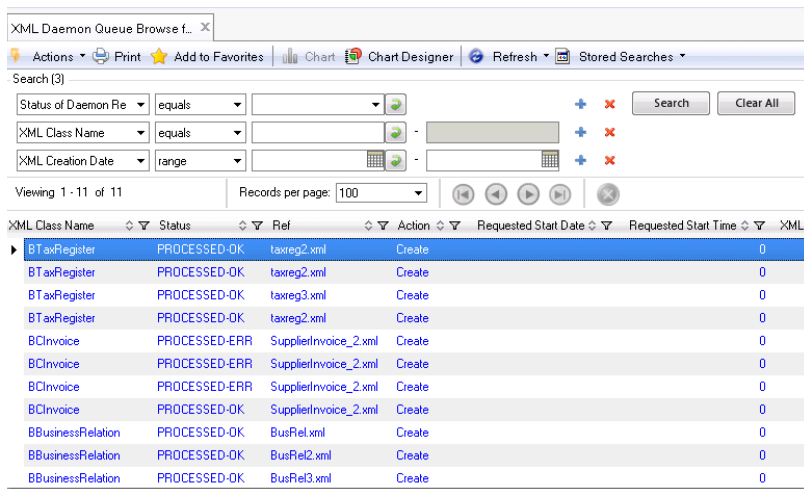
- Save
- Save/Create Draft
- Create Draft
- Validate

*Override XML.* Select the field to overrule the action specified in the XML file with the action defined in the Activity field.

## Queue View

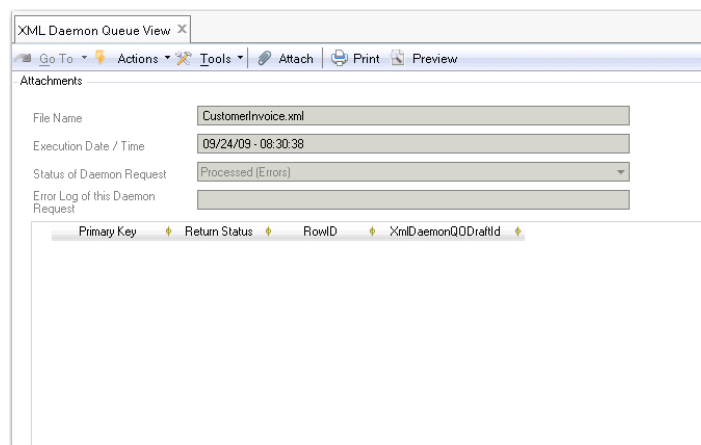
XML Daemon Queue View (36.14.16.7.1) lets you view the results of the daemon activity since the last time the queue was cleared. When you open the window, a browser displays where you can enter criteria to refine your search.

**Fig. 5.18**  
XML Daemon Queue Browse



Double-click on a queue record to view it in more detail.

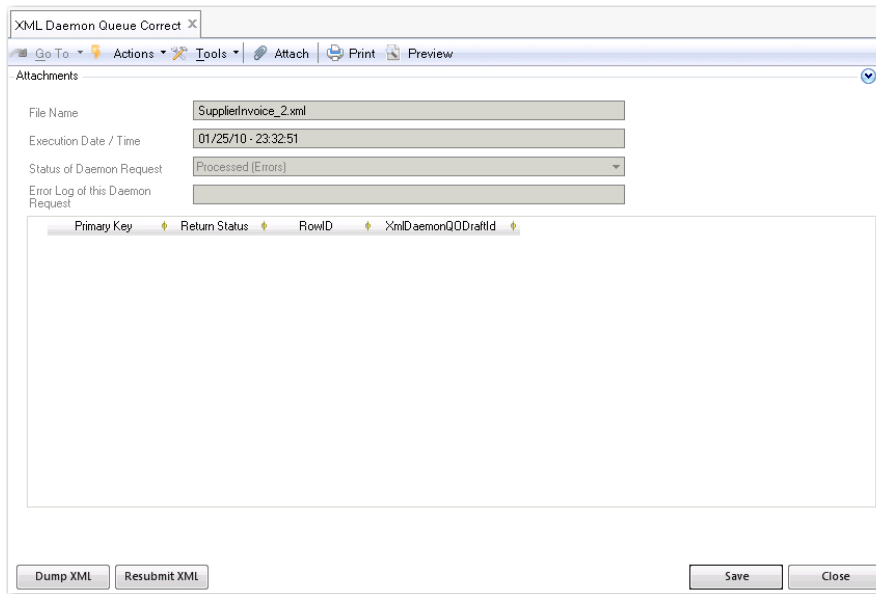
**Fig. 5.19**  
XML Daemon Queue View



## Queue Correct

XML Daemon Queue Correct (36.14.16.7.3) lets you correct object errors in queue requests. When you open the window, a browse displays where you can enter criteria to refine your search. Double-click on a queue record to open it in XML Daemon Queue Correct.

**Fig. 5.20**  
XML Daemon Queue Correct



Click on Dump XML to export a copy of the XML file that was submitted to the daemon.

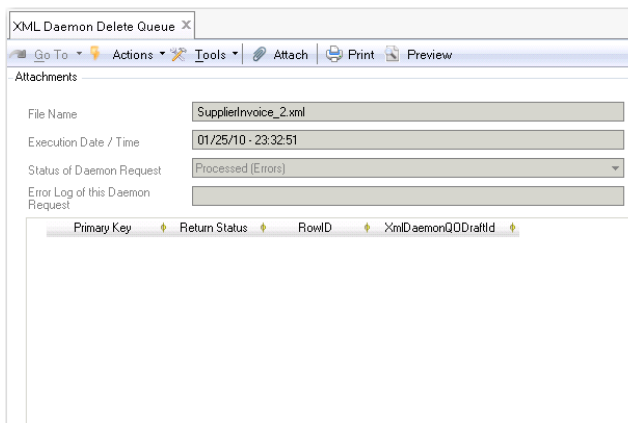
Click on Resubmit XML to relaunch corrected objects to the daemon queue.

## Queue Delete

Use XML Daemon Delete Queue (36.14.16.6.7) to delete individual queue entries for the XML daemon. When you open the window, a browse displays where you can enter criteria to refine your search. Double-click on a queue record to open it in the XML Daemon Delete Queue screen.

Click on the Delete button at the bottom of the screen to delete the queue request.

**Fig. 5.21**  
XML Daemon Delete Queue



## Running Daemons on the Command Line

The application control program, `applicationcontrol.p`, can be used to start and stop system daemons on the command line, without launching the application interface. Use daemon-specific parameters to start and stop daemons, and display limited daemon status.

## Integrating XML Documents

Data can be imported into QAD Enterprise Edition from an external customer system in a number of ways:

- In Excel files, using the Excel integration function available for many components. This function is mainly used for static components, such as GL accounts or cost centers (but can also be used for journal entries).

The Excel integration function lets you export existing static components to an Excel spreadsheet. You use the spreadsheet as a template in which to enter new data, and re-import the data as new data objects. For more information on Excel integration, see *Introduction to QAD Enterprise Applications User Guide*.

- As XML files, using the XML Daemon or QXtend Inbound functions. This technique is mainly used for dynamic components, such as transactions.
- As XML files, using EDI eCommerce. See *QAD EDI eCommerce User Guide*.

The Excel and XML-based functions convert the imported file to an Enterprise Application business object, such as a business relation or customer invoice, which can then be processed by standard Enterprise Financials applications. The imported file must contain essential data and conform to a set file structure in order to be processed successfully as a Financials business object.

Each component has an XML schema file, which describes the structure of its data. The structure of XML documents must conform to the schema file of the business component to which they will be converted. You must therefore prepare your document carefully before beginning the integration process.

## Planning the Integration

There are a number of scenarios in which a customer uses XML to migrate their data into the Financials application. For example:

- The customer is using an add-on product (for example, a payroll system) and needs to process payroll transactions using Financials functions.
- The customer is using an add-on product (for example, a separate order entry system) and needs to process orders as Customer Invoices.

In these situations, the original data must be converted to XML in order to be integrated into the Financials system.

Before you begin the integration process, you must identify key information:

- Which Financials business component will be used to process the data?
- How is the component structured, and what are its dependant components?
- Which tables are updated by this component and what are its mandatory fields?

- Which component schema files and sample files do you require?
- What are the editing guidelines for creating an XML file from your data?
- Which Enterprise Edition tools do you use to complete the integration?

## Identifying Business Components

When you have decided on the purpose of the integration (to create a customer or supplier opening balance, to complete banking entries for posted transactions, or to complete AR or AP payment cycles), you then identify the business components you want to be use to process the imported data.

For example, you may want to process payroll transactions for wages already paid as banking entries. You need to import both the transaction data and the employee data, and may want to import the employee data to be used as Financials system Employees. The components you will need are Banking Entry and Employee, and the data you import must comply with the schema files for these components.

To identify the name of the business component you need:

- 1 Right-click on the menu item.
- 2 Choose Properties.
- 3 Check the URI field.

For Financials objects, the name is typically in the format

```
urn:cbf:<businessComponent>.<Activity>.
(for example, BBusinessRelation.Modify)
```

You can now view the HTML documentation for this component. See “Tables and Mandatory Fields” on page 131.

You normally use the Business Relations component when importing customer or supplier address and contact information. Business relations contain location and contact information for all addresses defined in the system. They also contain tax details that are directly referenced or used as defaults for customers and suppliers. Therefore, when converting your data to a dataset that can be processed as a Financials component, you should be aware of the component structure.

## Identifying Components for Customer and Supplier Invoices

Posted customer and supplier invoices differ from other components in that the invoice can consist of two parts:

- The invoice posting
- The related journal entry postings

A standard Financials supplier or customer invoice posted to the official layer automatically contains all the required posting data. If you are integrating invoices that match the standard posted Financials invoice in every respect, you can therefore generate an XML dump from a Financials invoice to use as a template for integration. The components you need in this case are `BDInvoice` and `BCInvoice`.

If, however, you are integrating invoices that use different posting rules (for example, different expense or tax accounts, or different allocation), you should be aware that your integrated file must contain both the customer invoice data and the related journal entry data. In this case, the components you need for a posted customer invoice are `BDInvoice` and `BCJournalEntry`, and for a posted supplier invoice, `BDInvoice` and two `BJournalEntry` components (containing `SI Posting` data and `Matching Posting` data respectively).

When you have modified the field values with your data, you then combine the files into one. Schema files are available for a posted customer invoice (`BDInvoiceJournalEntry`) and posted supplier invoice (`BCInvoiceJournalEntry`), and you must rename the tags in your combined files to conform with these schemas.

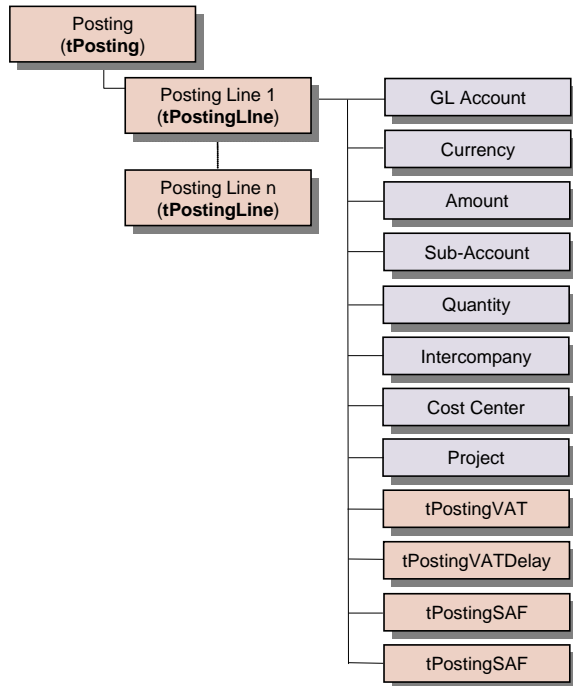
### Business Component Structures

Each business component dataset contains data tables. Static components, such as SAF concepts, contain master or parent data tables only, whereas complex components such as transactions contain both parent and child data tables.

For example, the `BJournalEntry` component contains the `tPosting` table, a `tPostingLine` table for each posting line in the transaction, the tax tables `tPostingVAT` for tax postings, and optionally, the SAF posting table `tPostingSAF`.

The component tables also contain fields. In the case of `tPostingLine`, GL account, currency, amount, sub-account, and other accounting fields are defined for each posting line. Each posting line can also optionally have tax tables and SAF tables (when SAFs have been defined for cost centers or projects).

**Fig. 5.22**  
Journal Entry Component Structure



When creating an XML file to be processed as a Financials journal entry, therefore, it is important to identify the fields, tables, and table relations of the `BJournalEntry` component. The XML file you import into Financials must contain the same fields and tables as the component you intend to use. This information is defined in the component schema file.

The schema files for each Financials business component are located in the `<installdir>\qadfin\components\progress\xml\*.xsd` directory.

## Tables and Mandatory Fields

Each component contains mandatory fields, which must be given values in order for the component to be validated. Information on these fields, and on the component tables, is contained in the component API documentation.

API documentation is provided in HTML format with each QAD Enterprise Financials release. It is stored in the `HTMLdocumentation` folder in your installation directory in a file called `QADFIN_Documentation.zip`.

The API documentation provided for each Financials business component consists of HTML pages with information about Financials projects, and the components used in projects. The main `index.htm` file for the project lists each component by business area, and you click the link for the specific component to display its own index page.

The component index page is divided into the following areas:

- Public data items
- API queries
- API methods
- Other methods
- Activities

Click the `class dataset` link in the public data items area to display the component dataset attributes.

Figure 5.23 displays the class dataset for `BSafConcept`.

**Fig. 5.23**  
BSafConcept Dataset

```
project QadFinancials > class BSafConcept > dataset BSafConcept
class dataset

object identification
primary key
SafConcept_ID
alternate key
SafConceptCode
object identity
SafConcept_ID

table tSafConcept

Annotation
<QUERYTYPE=Application Table - Master Data>
```

field name	data type	mnd.	description
SafConcept_ID	integer	yes	Record ID
SafConceptCode	character	yes	SAF Concept Code
SafConceptDescription	character	yes	SAF Concept Description
SafConceptIsActive	logical	yes	Active
SafConceptIsSystem	logical	yes	Flag indicating if this is a system concept
LastModifiedDate	date	no	Last Modified Date
LastModifiedTime	integer	no	Last Modified Time
LastModifiedUser	character	no	Last Modified User
tc_Rowid	character	yes	primary index
tc_ParentRowid	character	no	empty string
tc_Status	character	no	update status

This component contains the table `tSafConcept`, and contains the following mandatory fields:

```
SafConcept_ID
SafConceptCode
SafConceptDescription
SafConceptIsActive
SafConceptIsSystem
tc_Rowid
```

**Note** Although the field `SafConcept_ID` is defined as mandatory in the documentation, you must leave `_ID` fields blank in the XML file to be imported.

The SAF Concept component is a static component, containing a single table. Complex components, such as `BJournalEntry`, contain multiple tables, which are linked by parent-child relations. The API component documentation lists the component fields and describes them by name, description, datatype and mandatory status. The documentation also lists the component tables, but not the parent-child table relations, which are contained in the `tc_rowid` and `tc_parentrowid` fields in the component schema file, and described in detail in the component API documentation.

## Component Schema and Sample Files

Each QAD Enterprise Edition calling program is associated with an XML schema file. The schema file provides the definition of the component structure.

The XML schema for a calling program such as Supplier Invoice (`BCInvoice.XSD`) contains all possible data entry fields in the component, and details the component tables. It also includes the information required to start data iterations and information on the calling procedure.

The `tc_Rowid` and `tc_Parentrowid` fields in each table section indicate the parent or child table relations.

Sample values for these fields are displayed in the component sample file.

### Supported Components

The following table lists the components that you can import using Excel, QXtend Inbound (QXI), or the XML Daemon:

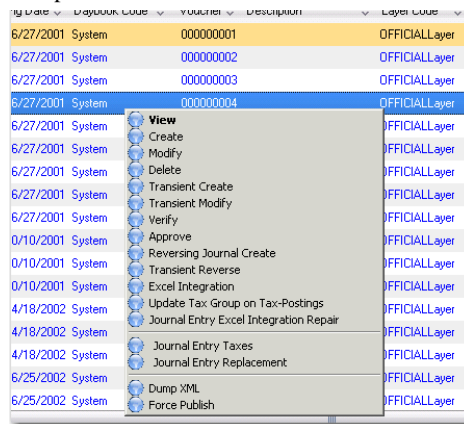
**Table 5.2**  
Component Schema File

bbudgetgroup	bcashgroup	bcdocument	bcinvoicejournalentry
bcurrency	bddocument	bdebtorcreditrating	bdebtoenduser
bdebtorshipto	bdebtortype	bdinvoice	bdinvoicejournalentry
bdomain	bemployee	bexchangerate.xsd	bexchangeratetype
bgl	bglcalendar	bglmask	bjournalentry
blanguage	blayer	bmirroringgl	bmirroringjournal
bpaymentcondition	bpaymentformat	bpaymentgroup	bperiod
bprofile	bproject	bprojectgroup	bprojectstatus
bpurchasetype	breason	broundingmethod	brole.xsd
bsaf	bsafconcept	bsafstructure	bsafstructurelink
bsettings.xsd	bsharedset	bstate	buser.xsd
buserrole	bvat	bvatbox	bvatgroup
bvatperiod	byearclosing		

### Sample XML Files

You can create a sample XML file for all components using the right-click Dump XML option available in browse results screens. The XML dump file is stored on the application server.

**Fig. 5.24**  
Journal Entry View, Dump XML



The Dump XML feature has two options:

*Dump All Fields (QAD XML export format).* This option dumps every field in the browse to XML.

*Only dump fields for import (QAD XML Import Format).* This option dumps only the fields you require if you are using the dump XML file to import external data into the application. The system removes the following non-essential fields from the XML dump:

```
tContextInfo.tcInvolvedCompanyCodes
tContextInfo.tcCorrelationId
tContextInfo.tcObjectIdentifier
*_ID fields for each table in the XML document/dataset
tc_status fields for each table in the XML document/dataset
```

The XML files created with this option conform with the schema file for the component, and provide sample values for all fields and table relations for that record. The data contained in the dump XML file is specific to the records you selected.

## Creating the XML File

The following section describes rules and editing guidelines for XML file content.

### tContextInfo Table

Each component schema file contains a `tContextInfo` table, which must be included in the XML file to be processed. This table is necessary for the system to process the XML file correctly.

`tContextInfo` contains the following fields:

- `tcCompanyCode`

The `tcCompanyCode` field is mandatory, and indicates the code for the entity in which the data will be processed. If you do not specify the company code, the company code of the current XML daemon process is used, which can lead to data conflict. The daemon does not give an error if this code is not specified.

- `tcAction`

The `tcAction` field is optional. The value of `tcAction` will only be taken into account if the XML daemon is configured so that the default action specified in the daemon configuration can be overridden by the `tcAction` specified in the XML file.

The possible values for `tcAction` are:

- `save`

The data is passed to the back end, and the system attempts to validate and save it. If this is not successful, the load of the XML document fails.

- `store`

The data is passed to the back end. The system does not validate it, but saves the data as a draft object.

- `validate`

The data is passed to the back end and the system tries to validate it without saving to the database.

- `savestore`

The data is passed to the back end, and the system tries to validate it. If the data validates, it is saved to the database. If it does not validate, the data is saved as a draft object. In Create mode it means that the object is not available as a real object in the system yet, and needs to be completed. In Modify mode the modification of the object is incomplete, and it can be completed only by completing the draft object.

- `tcOriginator`

The `tcOriginator` field is optional. (XML daemon only). It can be used by the external party to specify the origin of the data. This can refer to an originator defined within the configuration of the XML daemon, and can indicate if the default action for the originator can be overridden by the value in the XML file.

- `tiPriority`

The `tiPriority` field is optional. (XML daemon only). It can be used to indicate the priority of the XML document. The XML documents in the queue are processed in order of the lowest value set in `tiPriority`.

- `ttRequestStartDate`

The `ttRequestStartDate` field is optional. (XML daemon only). It can be used to indicate that the object in the XML document can only be processed after a certain date.

- `tiRequestStartDate`

The `tiRequestStartDate` field is optional. (XML daemon only). It is useful in combination with `ttRequestStartDate` to specify an integer value for the time before which the XML document will not be processed.

- `tcComment`

The `tcComment` field can be used to specify extra comments for the XML document in the queue. (XML daemon only). It can be viewed in the XML daemon monitor.

**Note** The `tcComment` field can also include:

```
PartialUpdate=<true/yes>
PartialUpdateExceptionList=t<table>.<field>
```

These fields exist as separate configurable fields in later releases and are described in “`tlPartialUpdate`” on page 136.

- `tcCBFVersion`

The `tcCBFVersion` field is mandatory and should contain the expected Component Builder version number. This field defines the way in which the XML document is constructed. (XML daemon only). The current version is 9.2.

- `tcActivityCode`

The `tcActivityCode` field is not mandatory, but is used to indicate the activity that needs to be executed for the data inside the XML document. If the `tcActivityCode` field is not specified, or left blank, the system decides the activity. If it cannot find the object based on the alternate key, it assumes the object must be created, and assumes that the `activitycode` is Create. If it finds the object, it assumes the `activitycode` is Modify. Possible values are:

- Modify

The object is taken in Modify mode. If this is specified, the validation will return an error if the object does not exist (based on the alternate key field search).

- Create

The object is taken in Create mode. If this is specified, the validation will return an error if the object already exists (based on the alternate key field search).

- Delete

The object is taken in Delete mode. The system tries to find the object, and deletes it.

- `tlPartialUpdate`

The `tlPartialUpdate` field is optional. It can be used to indicate how the system should treat the data that is passed to it. By default the value of this field is false; this means that the data supplied in the XML document is assumed to be complete. This is typical for a Create activity. For a Modify activity, however, `tlPartialUpdate` is useful in preventing the need to pass the complete component with all fields. This can be difficult when components have records in multiple class tables.

If `tlPartialUpdate` is set to true, the data supplied in the XML document is assumed to be incomplete. This allows for the situation in which there may be missing tables or fields. The system then performs a partial update, and does not try to assign default empty values to these fields, or delete child records.

However, you also have the option to identify records to be deleted. By assigning the `tc_Status` field of a child record to D, you indicate to the system that this record is to be deleted.

In this way, you can use the `PartialUpdate` option to supply only relevant field data for integration instead having to supply the complete dataset. `PartialUpdate` not only disregards fields that were missing in the input, but also disregards fields that are passed with an unknown value.

- `tcPartialUpdateExceptionList`

The `tcPartialUpdateExceptionList` field is not mandatory, and is only read by the system when the `tlPartialUpdate` field is set to true.

When a field has an unknown value, the system assumes that this field does not need to be updated. Use the `tcPartialUpdateExceptionList` field to specify a comma-separated list of fields that must be updated in the database, even if their value is unknown.

The syntax for the exception list field names is `t<table-name>.<field-name>`.

**Example** `tBusinessRelation.BusinessRelationName1`

## Rowid Fields

The values of the `rowid` fields in the XML document are used to map the parent-child relationships between tables. You can assign any values to these fields, while ensuring that the `tc_parentrowid` of the child record matches the `tc_rowid` of the parent. When the system processes the XML files, it uses this matching to map the tables, then assigns its own values to the `rowids` in the database.

**Important** The `tc_rowid` value must be unique within the records of the same table in one XML document.

**Example** An XML file containing business relation data contains the tables `tBusinessRelation` and two `tAddress` tables, one of which contains a `tContact` table.

To map these tables, you set the value of the `tc_rowid` of the `tBusinessRelation` record to -1.

The `tc_parentrowid` values of the `tAddress` child records are therefore also set to -1.

The `tc_rowid` values of the `tAddress` tables are set to -2 and -3.

The `tContact` table is the child of the `tAddress` table whose `tc_rowid` is -3. Its `tc_parentrowid` is therefore set to -3, and its `tc_rowid` to -4.

**Fig. 5.25**  
Parent/Child Relations

```
<tBusinessRelation>
  <BusinessRelationCode>Acme</BusinessRelationCode> etc...
  <tc_Rowid>-1</tc_Rowid>
  <tc_ParentRowid/>
  <tAddress>
    <AddressStreet1>11811 WILLOWS RD NE</AddressStreet1> etc...
    <tc_Rowid>-2</tc_Rowid>
    <tc_ParentRowid>-1</tc_ParentRowid>
  </tAddress>
  <tAddress>
    <AddressStreet1>8787 Main Street</AddressStreet1> etc...
    <tc_Rowid>-3</tc_Rowid>
    <tc_ParentRowid>-1</tc_ParentRowid>
    <tContact>
      <ContactName>Joe Bloggs</ContactName> etc...
      <tc_Rowid>-4</tc_Rowid>
      <tc_ParentRowid>-3</tc_ParentRowid>
    </tContact>
  </tAddress>
</tBusinessRelation>
```

You must specify the `rowid` fields if you have multiple record requests in your XML request.

### Custom Fields

Most tables contain custom fields (for example, `<CustomShort0/>`, `<CustomShort1/>` ). Unless you have used these fields for customization, you can remove them from your document.

All components have also `tCustomTable0`, `tCustomTable1` and `tCustomTable2` tables in their schema file. These are not mandatory and can also be used for customization of the business component. If defined, you may want to keep this fields in your document.

### Last Modified Fields

These fields are generated by the system and can be removed from your document. For example:

```
<LastModifiedDate>2009-01-15</LastModifiedDate>
<LastModifiedTime>9874</LastModifiedTime>
<LastModifiedUser>mfg</LastModifiedUser>
```

### ID Fields

ID fields are not necessary for XML integration. These fields are generated by the Financials component when the file is processed.

You can remove these fields automatically using the Only Dump Fields for Import option in the Dump XML feature (see “Sample XML Files” on page 133). For XML files that have not been created using this option, you can remove the ID fields manually.

For example, in the following section of a supplier invoice sample XML file, you remove the `CInvoice_ID`, `Company_ID`, `Period_ID`, `Creditor_ID`, `Division_ID`, and `Journal_ID` fields, but retain the `CInvoiceType` and `CInvoiceVoucher` fields:

```

<CInvoice_ID>738175</CInvoice_ID>
<Company_ID>9144</Company_ID>
<Period_ID>16683</Period_ID>
<Creditor_ID>173655</Creditor_ID>
<Division_ID>11438</Division_ID>
<Journal_ID>271904</Journal_ID>
<CInvoiceType>INVOICE</CInvoiceType>
<CInvoiceVoucher>0</CInvoiceVoucher>

```

## Primary Key Fields

Primary key fields are a combination of fields that combine to uniquely identify the object in the system.

For example, the primary keys for Supplier Invoice and Journal Entry are a combination of Entity, Posting Year, Daybook, and Voucher. The Entity, Posting Year, and Daybook require values in an XML file to be integrated. The Voucher field is generated by the system.

When you modify or delete a record, the `<AddressLogicKeyString>` key field is also required. You can view the field by dumping the XML for a particular business object using Actions| Properties and then Dump XML. You can also query the `AddressLogicKeyString` key field using a Progress editor.

**Note** You cannot view the `<AddressLogicKeyString>` field in the user interface.

## Integrating Multiple Records in an XML Document

You must apply the XML document guidelines described in this chapter to all the records you want to integrate, and you include all records of the same type (for example, all Employee records) in a single XML document.

## Processing the XML File

The completed XML file can be processed in one of two ways:

- Using the XML daemon to collect the file and process it.  
The XML daemon processes external XML data. You store the XML file to be processed in a specified directory on the server. The daemon then reads and processes the file. See “XML Daemon” on page 123.
- Using QXtend to convert the XML file to a QDoc to be processed by the QXInbound engine.  
QXtend Inbound delivers inbound data to business component programs in QAD Enterprise Edition. The inbound data is in the form of XML data documents, called QDocs, delivered in either a proprietary XML format or, for a select few programs, as direct code APIs. QXtend Inbound operates over SOAP (Simple Object Access Protocol), and XML documents must be contained in a SOAP envelope in order to be processed.

For more information on QXtend Inbound and QDocs, see *QAD QXtend User Guide*.

## Bulk Data Load

The Excel Integration menu activity is available for a number of business components in Enterprise Financials. For more information on Excel integration, see *Introduction to QAD Enterprise Applications User Guide*. However, when importing very large amounts of data to the system, Bulk Data Load (36.24.8) is a more efficient utility. It is useful when setting up an implementation.

Bulk Data Load lets you import multiple .csv files into the system at once. It processes the contents of these files in batches, so that an error in one batch does not cause the entire import process to fail. You can use Bulk Data Load to import various types of information, as listed in Table 5.3.

**Table 5.3**  
Information Imported by Bulk Data Load

Business relations	Daybooks	Projects
COA cross references	Employees	SAF codes
Cost center masks	End Users	Sub accounts
Cost centers	Exchange Rates	Sub-account masks
Customer bank numbers	GL Accounts	Supplier bank numbers
Customer opening balances	Journal Entry	Supplier opening balances
Customer Ship To addresses	Project Masks	Suppliers
Customers		

The order of files in the grid determines the order in which the files are imported, with the first file in the list processed first. To prevent errors, follow the recommended order for importing shown in Table 5.4.

**Table 5.4**  
Recommended Data Import Sequence

Import Group	Sequence	File Contents
1	1	SAF Codes
1	2	Business Relations
1	3	Daybooks
1	4	GL Accounts
1	5	Sub-Account Mask
1	6	Sub-Accounts
1	7	Cost Center Mask
1	8	Cost Centers
1	9	Project Mask
1	10	Projects
1	11	COA Cross Reference
1	12	Exchange Rates
2	1	Customers
2	2	Customer ship-tos
2	3	Customer Bank Number
2	4	End Users
2	5	Customer Opening Balance

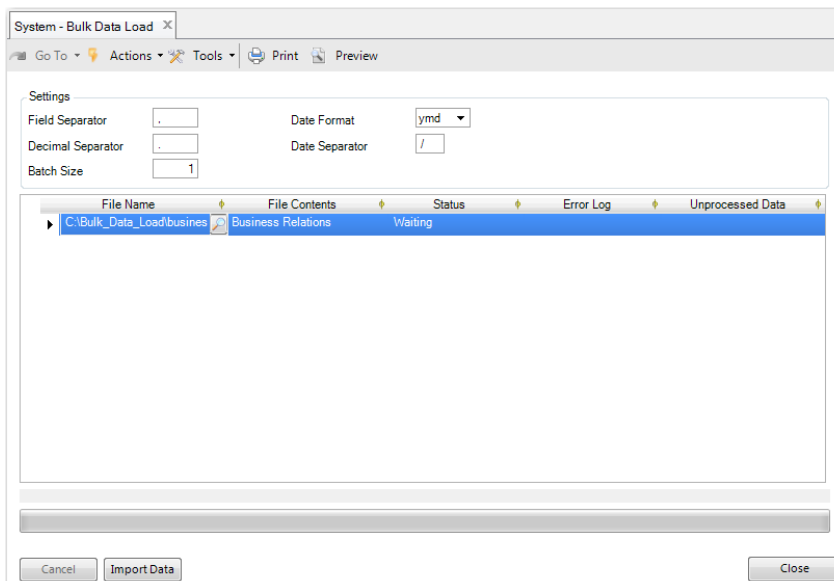
Import Group	Sequence	File Contents
3	1	Suppliers
3	2	Supplier Bank Number
3	3	Employee
3	4	Supplier Opening Balance
4	1	Journal Entries

The .csv files for Bulk Data Load have the same column headings as the .csv files used with the Excel integration feature. You can use the Export to Excel for Maintenance option available in the Excel Integration menu options to get a template for the file that you want to add in Bulk Data Load. For more information on Excel integration, see [Introduction to QAD Enterprise Applications User Guide](#). For example, to see the template for Cost Center Mask, open Cost Center Mask Excel Integration (25.3.9.2.6), right-click in the grid, and choose Export to Excel for Maintenance.

Apart from Customer Opening Balance and Supplier Opening Balance, all of the files in Table 5.4 have an equivalent Excel integration facility. To save a template of these two files, open Customer Opening Balance Create (27.1.10) and Supplier Balance Create (28.1.15), right-click in the resulting grids, and choose Export to Excel for Maintenance.

Bulk Data Load consists of a Settings section and a grid that lists the files for importing.

**Fig. 5.26**  
Bulk Data Load



The Settings section contains a number of fields:

*Field Separator, Decimal Separator, Date Format, Date Separator.* These fields contain information on the formatting of the .csv file contents. The default values for these fields derive from your computer settings. If the values of these fields do not match the formatting of the files in the grid, then an error displays. You can modify the contents of these fields to accommodate the file or files that you want to import.

**Note** The field separator and decimal separator cannot be the same character.

**Batch Size.** Specify the number of rows, between 1 and 1000, to include in each batch processed by Bulk Data Load.

**Note** Larger batches may sometimes result in faster processing, but can also result in a connection time-out if the batch size is too large. If an error occurs when processing a batch, then the entire batch is rejected. The recommended batch size is less than 500.

The Grid section displays the files that you wish to load into the system. There are two methods of adding files to the grid:

- Drag files from an Explorer window and drop in the grid. This option lets you add multiple files at once.
- Right-click on the grid, choose Insert a New Row from the resulting menu, and then select one or more files using the lookup icon in the File Name field.

There are a number of columns in the grid:

**File Name.** The name of the file that you are importing. Use the lookup to specify the file, or drag the file into the grid from an Explorer window.

**File Contents.** This field displays the type of data that the file contains. The system automatically detects the type of content in the file and updates this field accordingly.

**Status.** There are four possible statuses:

- Waiting
- Cancelled
- Complete
- Errors

**Error Log.** If there is an error with the import, then the details of the error are stored in a file called

`<FILE-NAME>-errors.txt`

where `<FILE-NAME>` is the name of the file that you added to the grid for import.

To access the file, click the link in this field.

**Unprocessed Data.**

If the import does not fully complete, then the lines that are not processed are stored in a file called

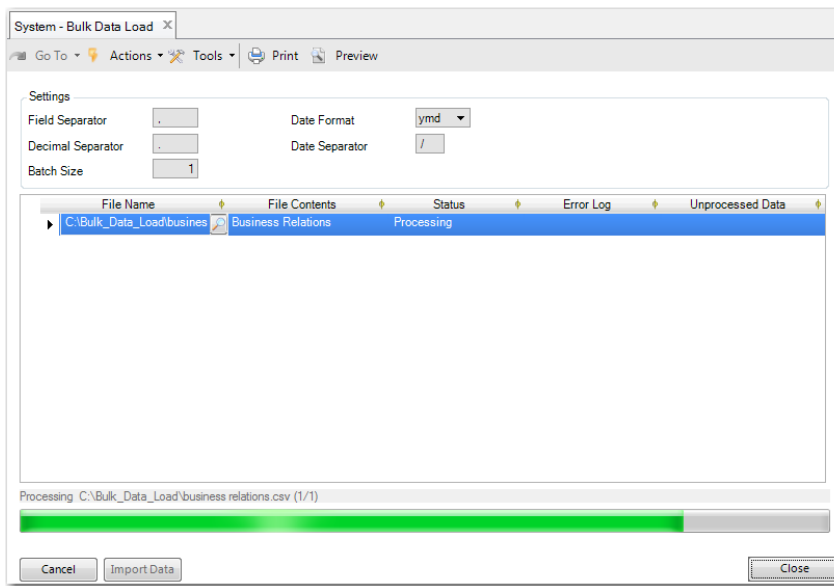
`<FILE-NAME>-failed.csv`

where `<FILE-NAME>` is the name of the file that was not fully imported.

To access the file, click the link in this field.

To import the files in the grid, click Import Data. A progress bar appears at the bottom of the screen to show the files being imported. The name of the file being processed, including the full path, appears above the progress bar.

**Fig. 5.27**  
Bulk Data Load with Progress Bar



When the import begins, one or more log files are created with information on the progress of the import. A log file with the name

QAD-Bulk-Data-Load-Logging.txt

is stored in each folder that contains a file to be imported. The file contains information about the import of files stored in the folder, including the batches processed, and whether the import completed successfully.

To cancel the import process, click Cancel. The import process stops after the current batch is processed. Unprocessed lines are stored in a file accessible from the link in the Unprocessed Data column for the corresponding row in the grid.

# System Control

This chapter describes essential configuration tasks and administrative options.

**System Control Overview 144**

Explains the functions of the System Control menu.

**Database Control 144**

Explains how to use Database Control.

**System Maintenance 145**

Explains how to manage system settings using System Maintain, System Synchronize, System View System Codes, System Monitor, the Set Debug Level option, and the CT log file. It also covers server.xml.

**Configuring System and User Settings 154**

Discusses system and user settings and how to change them.

**Making UI Caching Configurable 158**

Explains how to configure the system to prevent the UI from automatically caching the result of method calls.

**Configuring Workflow 159**

Explains how to configure and change the workflow.

**Managing Draft Objects 159**

Explains how to use Draft Object Modify.

## System Control Overview

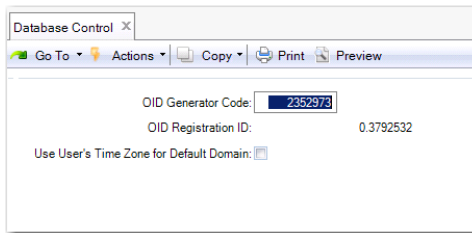
The functions on the System Control Menu (36.24) let you configure and manage settings at the database level. The System Administration function lets you perform the administration tasks required to configure and monitor QAD Financials. These include tasks to:

- Define database control settings.
- Configure system and user settings.
- Set up workflow.

## Database Control

Use Database Control (36.24.1) to set the time zone of the database server and to register a code for defining unique record identifiers. You should do this before defining users since the time zone specified here defaults when new user records are created.

**Fig. 6.1**  
Database Control (36.24.1)



**OID Generator Code.** The OID Generator Code in Database Control is used to assign unique object identifiers (OIDs) to database records for auditing purposes. The code is assigned during system implementation.

Based on the OID generator code, the OID fields in the database are populated using an algorithm that ensures uniqueness across all records, tables, and QAD databases within the company. The value stored in the OID field for each record has the following decimal format:

```
<date><seq_value>.<registration_id>
```

Where:

<date> is the server date with format yyymmdd.

<seq\_value> is obtained from a Progress database sequence.

<registration\_id> identifies the origin of the OID value.

The registration ID is derived from the OID generator code by reversing the digits of the generator code value and placing the decimal point in front of the result.

**Use User's Time Zone for Default Domain.** The Use User's Time Zone for Default Domain field in Database Control (36.24.1) affects the time stamping of transactions you create in the default domain. If the Use User's Time Zone for Default Domain field is selected, all transactions you create in the default domain are dated and time stamped according to the user time zone specified in User Maintenance (36.3.1), even if a different time zone is defined for the domain in the Domain record.

If the Use User's Time Zone for Default Domain field is deselected in Database Control (36.24.1), all transactions you create in the default domain use the time zone defined in the Domain record. The Use User's Time Zone for Default Domain field is deselected by default. A user's default domain is set in User Domain/Entity Access Maintain. (36.3.4).

**Important** If you are using the optional Service/Support Management module and the Multiple Time Zone option is activated in Service Management Control (11.24) for any domain in the database, you should not activate this field.

## System Maintenance

You can use the following activities to manage system settings:

- Use Maintain to configure the main system setup definitions.
- Use Synchronize during initial system installation and to enable new features after a software update.
- Use View System Codes to display the list of values for fields that display valid values in drop-down lists.

### Maintain

The System Maintain activity lets you configure the system setup, and describes the system-level values that are applied to all domains and entities.

**Note** The system settings must be defined before you create domains and entities.

**Fig. 6.2**  
System Maintain (36.24.3.1)

The screenshot shows the 'System Maintain' configuration window. It features a menu bar with 'Go To', 'Actions', 'Tools', 'Print', and 'Preview'. The main area contains a list of system settings, each with a corresponding input field or control:

Database Language	SI
Domain	QAD
System Admin Login	QAD
System Admin Password	*****
Application ID	Financials
Reporting Currency	USD
Budget Enabled	<input checked="" type="checkbox"/>
Check Budgets on Overlap	<input type="checkbox"/>
OL Check on Budgets	<input type="checkbox"/>
Specific SI Approval	<input type="checkbox"/>
Business Relations By Domain	<input type="checkbox"/>
Invoice Certificate	1352
Version	1
Public Key	-----BEGIN PUBLIC KEY-----
Open SSL Directory	D:\Program Files\OpenSSL-Win32\bin
Bank File Batch Size	
Payment Selection Confirm Batch Size	1000

## Field Descriptions

**Database Language.** Choose the system language from the drop-down list. The system language is used to determine the language of UI elements if a user logs in and no UI strings are found in the language associated with their user record.

**Domain.** Enter the code that identifies the system domain. By default this is set to QAD. The system domain includes default data that is copied to new domains that are created, including control program settings, default accounts, and generalized codes. The system domain is used as a template for new domains.

Since the system domain is used as a template, you can add data to it or tailor defaults before creating new domains based on it. For more information on the system domain, see [QAD Financials User Guide](#).

**System Admin Login.** Specify a user ID to be used for system startup activities that can be run from a shortcut or as a scheduled task in Windows. These activities include system integrity checking, synchronize, starting the application, and starting the daemons. A valid user ID is required to ensure that a session can be created. By default this is set to the initial user, mfg.

**System Admin Password.** Specify the password for the system administration user ID.

**Application ID.** Specify an ID for this instance of the application (maximum 24 characters).

**Reporting Currency.** Specify the reporting currency to use for this database.

**Important** Make sure you specify a reporting currency before you initiate any transactions in the database; it cannot be modified once GL transactions exist.

**Budget Enabled.** Select the field to enable budgeting. If you clear the field, the Budgeting function is disabled, and you cannot create new budgets or modify existing ones.

If your organization does not use budgeting, you should deactivate it to improve system performance.

**Important** If you disable the Budgeting module, you also disable the ability to create allocation transactions based on WBS topics.

**Check Budgets on Overlap.** Select this field to verify that the same combination of budget elements (GL accounts, sub-accounts, cost centers, projects, and SAFs) is not being used in different budget topics or in different budgets. This setting is only applicable for budgets that also overlap in time; for example, overlapping budget periods. When the field is selected, the system generates an error message when a conflict occurs.

This verification process adds considerably to the length of time taken to save and run a budget.

**OL Check for Budgets.** Select the field to enable the online budget check.

Each time a linked budget account is specified in banking entry, journal entry, customer and supplier invoices, open item adjustment, or petty cash activities, the system determines if the new transaction causes the budget amounts to be overrun.

**Specific SI Approval.** Select the field if the task of approving supplier invoices is assigned to a specific user role.

After you select the Specific SI Approval field, create a role that corresponds to the approver's user name; for example, SIA-xxxxxx, where xxxxxx is the user name of the approver. Link the new role to the approver's user name.

Choose the SIA-xxxxxx role as approver when you create supplier invoices. When you save the supplier invoices, the system sends them to the Workflow Inbox of user xxxxxx for approval. See "Configuring Workflow" on page 159 for information on setting up the Workflow Inbox.

**Note** The Role field displays in supplier invoice activities only if you customize the screen to add it. See Chapter 12, "UI Customization," on page 249.

*Business Relations By Domain.* Select this field to enable the restriction of business relations to domains. When you select this field, the Domain Restricted field is selected by default on each new business relation you create. When a business relation is restricted to a domain, it can only be viewed and accessed within the domain in which it was created. You can over-ride this setting by clearing the Domain Restricted field in Business Relation Create. For more information on business relations, see [QAD Financials User Guide](#).

*Invoice Certificate.* This field displays QAD's shipment and invoice certification number, assigned by the local government, where applicable. This field is updated using System Synchronize.

For more information on invoice certification, see [QAD Financials User Guide](#). For more information on shipment certification, see [QAD Sales User Guide](#).

*Version.* This field displays the version number of the public and private keys. This field is updated using System Synchronize.

*Public Key.* This field displays the invoice certification public key created by QAD. This field is updated using System Synchronize.

*Open SSL Directory.* Specify the OpenSSL bin directory. OpenSSL is used to generate the private and public keys.

This field is mandatory. You cannot enable invoice certification if you have not specified the OpenSSL bin directory.

*Bank File Batch Size.* Specify a value between 0 and 200 for the number of lines that you can include in a batch imported using Process Incoming Bank Files (31.1.6). The default value is 100.

*Payment Selection Confirm Batch Size.* Specify the maximum number of invoices that you can include in a batch processed using Supplier Payment Selection Confirm (28.9.4.5) or Supplier Payment Selection Unconfirm (28.9.4.8). The default is 1000.

See "Determining the Optimal Payment Selection Confirm Batch Size" for guidelines on setting the most appropriate batch size for your system.

**Note** Some batches can be less than the batch size specified in System Maintain. This situation occurs because the system avoids splitting payments for the same supplier into separate batches.

For more information on electronic banking and on supplier payment selections, see [QAD Financials User Guide](#).

## Determining the Optimal Payment Selection Confirm Batch Size

The optimal batch size for Supplier Payment Selection Confirm depends on your system configuration and hardware. The recommended approach is to determine the best batch size for your system using trial and error. However, you must consider the guidelines in this section.

If you set a batch size that is too high, you incur the risk that one batch cannot be completed successfully due to system constraints and concurring load conditions.

QAD tests have shown that a batch size of 1000 easily fits within the constraints for most systems. Therefore, 1000 is the default payment selection batch size. Starting from 1000, you can experiment and increase the batch size, for example, by 200 at a time and measure the time taken to process the batch. You can determine the time taken by monitoring the progress bar in Supplier Payment Selection Confirm.

If a batch of 1200 is processed successfully, try to process a batch of 1400, and repeat this process until you find the optimal batch size for your system.

**Important** Tests have shown that a batch size of 1500 is close to the maximum limit on some systems.

## Synchronize

The Synchronize activity is used to initialize a new system and to activate new features following a software upgrade. It can also be used to update the data in the system such as loading translated strings.

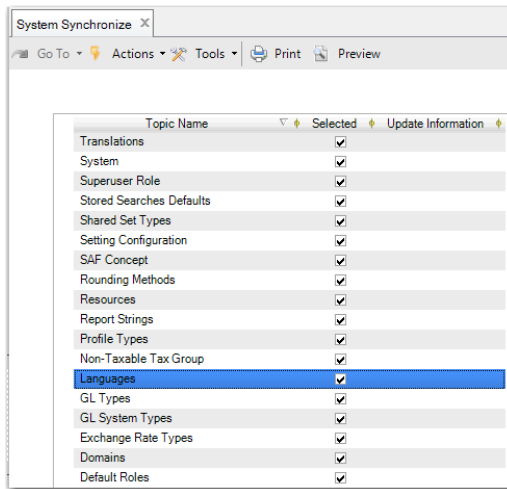
The system uses a number of database tables that must be current for the software version. Some components contain a method that updates the system tables. The Synchronize activity calls and runs these update methods.

Synchronize is typically run directly by the QAD Deployment Tool. You might need to run it for specific updates, such as installing a new language.

**Note** If you install a new language, you must synchronize both Translations and Areas, Classes, and Activities.

See the release documentation to determine if you must synchronize after you install a new software version. The synchronization must be performed once only.

**Fig. 6.3**  
System Synchronize (36.24.3.2)



## Field Descriptions

*Selected.* Select the areas to synchronize.

Selecting specific areas removes the need to synchronize the entire system, and decreases the synchronization time.

*Update Information.* When the synchronization is complete, this column displays the update status of the area.

## View System Codes

The View System Codes activity lets you view the list of values for fields that are validated using a drop-down list. When an integration is set up with an external system, consult this list to ensure that the data sent over by that system is valid.

**Fig. 6.4**  
System View System Codes (36.24.3.3)

The screenshot shows a window titled "System View System Codes" with a menu bar (System, Tools, Go To) and a toolbar. A "Business Component" dropdown menu is set to "Budget". The main area displays a tree view of system codes. The first section is expanded to show a table with columns "Name", "Column Label", and "Side Label". Below this, there are sections for "Display Value" and "Data Value", each with a table of values. The second section is also expanded to show another table with columns "Name", "Column Label", and "Side Label".

Name	Column Label	Side Label
tBudget.BudgetC	Report Period Ch	Report Period Ch
tBudget.BudgetFo	Forecast Type	Forecast Type
tBudget.BudgetO	GL Period Overru	GL Period Overru
Display Value		
No Action	NO	
Warning	WARN	
Error	ERR	
Data Value		
Name	Column Label	Side Label
tBudget.BudgetO	Total Overrun	Total Overrun
tBudget.BudgetO	Overrun (YTD)	Overrun (YTD)
tBudget.BudgetSt	Status	Status
tBudget.BudgetTy	Budget Type	Budget Type
tBudgetFDS.Budg	COA Element	COA Element
tBudgetVBS.Bud	COA Type	COA Type
tBudgetVBS.Bud	Cost/Revenue	Cost/Revenue
tBudgetVBS.Bud	Cost Type	Cost Type
tBudgetVBS.Bud	GL Period Overru	GL Period Overru
tBudgetVBS.Bud	Total Overrun	Total Overrun
tBudgetVBS.Bud	Overrun (YTD)	Overrun (YTD)
tBudgetVBS.Bud	Status	Status
tBudgetVBSItem	Origin	Origin

## Field Descriptions

**Business Component.** Choose the business component for which you want to view the list of values for fields. The name of the business area is displayed in parentheses beside the business component in the drop-down list.

**Name.** Displays the object name in the format:

t<table name>.<field name>

t indicates that the data type is text.

**Column Label.** Displays the field name as it is used in reporting lookups.

**Side Label.** Displays the field name as it appears in the UI.

**Display Value.** Displays the value that appears in the drop-down list in the UI.

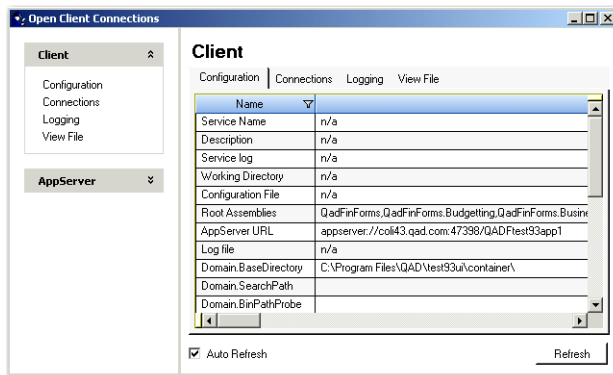
**Data Value.** Displays the system code as it is stored in the database. Use this value when interfacing from external systems.

## System Monitor

Use the System Monitor function to view information about the application. Two sets of information can be viewed: client settings and application server settings. Click on the various tabs to see additional details.

Use this information to monitor activity and help in troubleshooting.

**Fig. 6.5**  
System Monitor, Client Settings (36.24.3.4)



## Set Debug Level

The Set Debug Level (36.24.3.5) option lets you set the level of detail displayed in the `ctllog` file. You can display full business code, including parameter values and database queries. You can use the `ctllog` file to run a full trace on component methods and procedures.

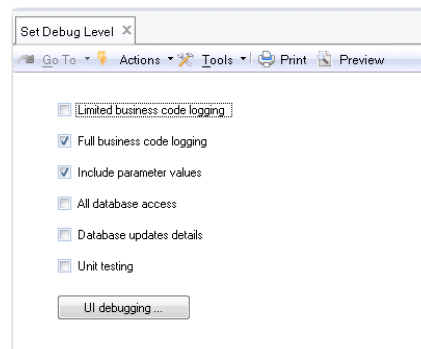
**Note** To run the system log, you must first close all other application screens.

When logging is enabled, you can run the function you want to customize, and then display the execution flow in `ctllog`. The log displays the business methods used in the function and how they are implemented.

The path and filename for the `ctllog` file are set in the `server.xml` file and you can view the filename in the Business Logging entry of the Appserver section of System Monitor (36.24.3.4).

Set the debug parameters and select Save to enable the logging.

**Fig. 6.6**  
Set Debugging Level



## Field Descriptions

*Limited Business Code Logging.* Select this field to log the start and end of all entry-level business methods. Entry-level methods are called from outside the business logic.

*Full Business Code Logging.* Select this field to log the start and end of all methods and procedures, internal and external.

When Full Business Code Logging is enabled, the CT Logfile also traces the execution of customized code.

*Include Parameter Values.* Select this field to include parameter values. This field is only available when you select Limited or Full Business Code Logging.

*All Database Access.* Select this field to include all read or update database queries. The read access logs the executed query statement and the number of records read. The update access logs the action and the `rowid` of updated records.

*Database Update Details.* Select this field to include details of all database updates (create, modify, or delete). The log entry contains the complete updated record.

*Unit Testing.* Select this field to log possible memory leaks. This logging checks for:

- Instances that have not been deleted
- Programs that have multiple instances running persistently
- Dynamic objects (datasets + temp-tables + queries + buffers) that have not been deleted
- Connected appservers
- Connected sockets

This logging also lists all persistent procedures and a total count of all database read access events.

*UI Debugging.* Click to display the View Performance Results screen and enable UI debugging.

## UI Debugging

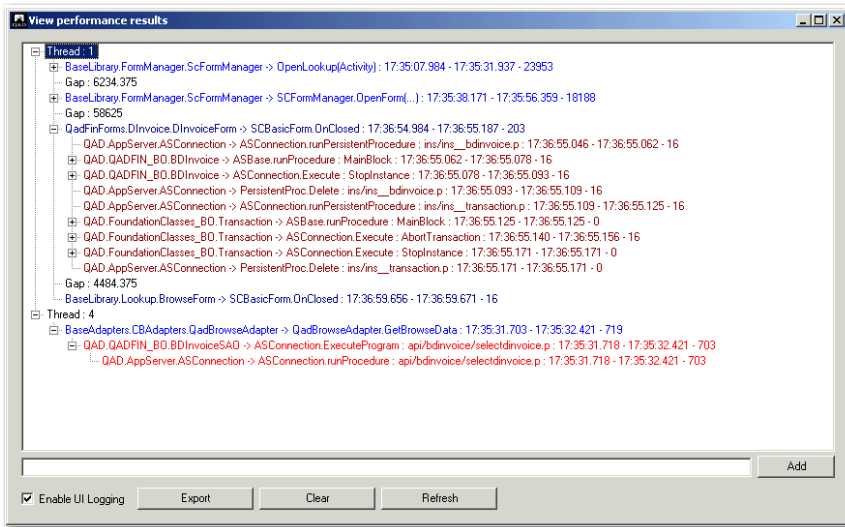
The UI debugging option lets you log UI methods and procedures. Select the Enable UI Logging field to begin logging, and click Refresh to view UI activity. Click Export to export the currently displayed information to a text file for analysis.

Server-side calls are indicated in red, and UI calls are indicated in blue. Darker red and blue lines indicate calls that take longer than 500 milliseconds. Each running thread is represented by a node in the tree view, and every browse or lookup activated creates a new node. You can add user comments (displayed in orange) to the log.

The Export button allow you to export the log details to a text file

**Note** UI debugging is activated in system memory, and for performance reasons, you should not enable the option permanently. Enable UI debugging for specific UI activities, export the thread for analysis, and then disable the option.

**Fig. 6.7**  
View Performance Results



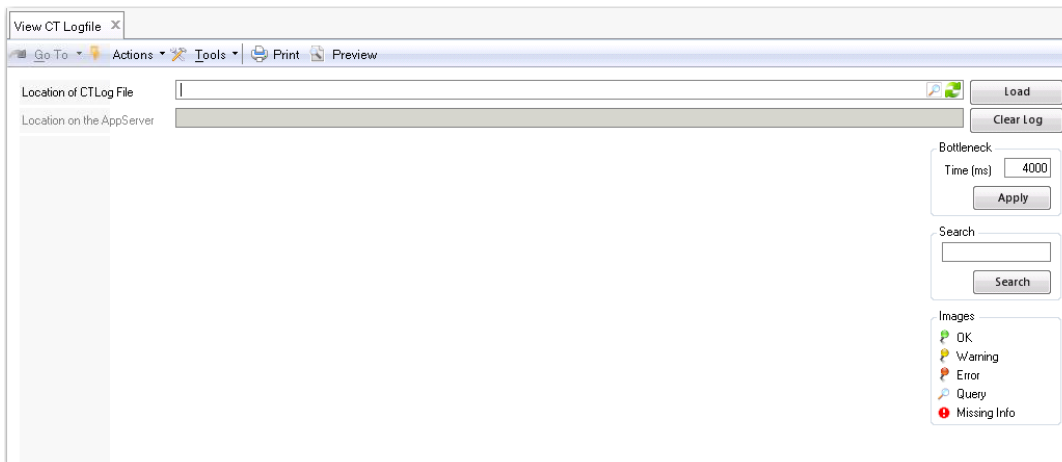
## View CT Logfile

Use this option to view the Code Trace (CT) Log. The CT Log performs a trace on the business methods used in a function, and is a valuable troubleshooting utility. The location of the log is set in the `server.xml` file:

```
<logging><LoggingDirectory>Directory on the AppServer host</LoggingDirectory></logging>
```

**Note** When Full Business Code Logging is enabled, the CT Logfile also traces the execution of customized code.

**Fig. 6.8**  
View CT Logfile



## Field Descriptions

*Location of CT Log file.* Enter the location of the CT Log file. This file location is specified in the `server.xml` file `<logging>` parameter. With the lookup button you can open a log file from any location you choose. The Business Logging entry in the Appserver area of System Monitor details the location of the log file for your current session.

*Load.* Click to load the file.

*Clear Log.* Clears the CT Log file during an ongoing session for which the debug level is set. As a result, the system logs the business logic trace information.

When you click the Clear Log button, the viewer screen is cleared.

*Location on the appserver.* This field displays the appserver location when you load the file. The client and appserver may have different mappings to the same location. This is especially true when you use a UNIX server.

*Bottleneck Time (ms).* Set a time in milliseconds after which an active business function is highlighted as a bottleneck. This lets you identify business functions that take a long time to complete and so may pose performance issues in the application.

*Apply.* Click to apply this bottleneck period to the log.

*Search.* Use this text search field to search the file for a text reference.

*Images.* Log entries are identified by the following types: OK, Warning, Error, Query, Missing Info.

## server.xml

The `server.xml` file contains the configuration of the business layer of the application. All configurable settings are included in this file. In this file, you can configure:

- The number of components that get cached on the appserver
- How to connect to the application databases
- The mail server to use
- Report settings
- Transaction settings
- Backend logging
- State storage settings
- Default data settings
- The appserver to start daemon instances

## Configuring System and User Settings

The system and user settings defined in these functions apply only to component-based programs; they do not affect standard Progress programs.

**Note** When you have changed settings at system or user level, to enable the changes you must then clear the client cache and re-start the Enterprise Financials appserver.

### System Settings

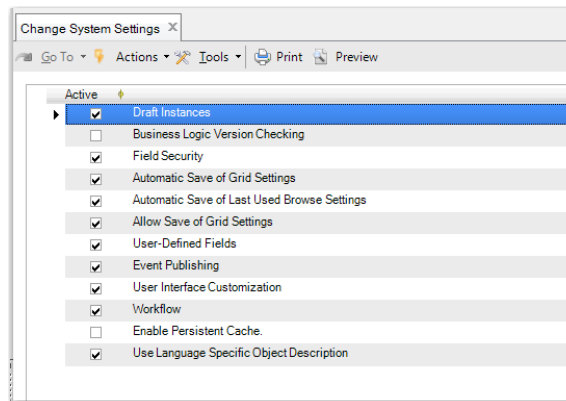
The System Settings function lets you modify system-wide settings that affect the areas of security, customization, and workflows related to component-based functions.

A subset of the settings can also be modified by users, but only if they are enabled system wide. If the setting is disabled, users cannot enable it.

The following settings are enabled by default: UI Customization and Automatic Save of Grid Settings. The others are disabled by default.

Enabling some of the features controlled here may affect system performance.

**Fig. 6.9**  
Change System Settings, (36.24.5.1)



## Field Descriptions

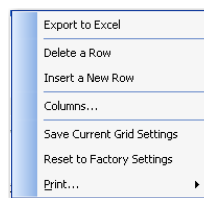
*Allow Save of Grid Settings.* Disable this if you do not want users to be able to choose to save grid settings. When this is disabled, the Save Current Grid Settings option does not display when users right-click in a grid. When this is selected, the option does display.

Enable this if you want grid settings saved only when a user specifies.

This setting interacts with the Automatic Save of Grid Settings. When grid settings are automatically saved, the Allow Save of Grid Settings has no effect.

The following figure shows the right-click grid menu when Allow Save of Grid Settings is enabled.

**Fig. 6.10**  
Change System Settings, Right-Click Grid Menu



When this option is enabled, individual users can disable it in User Settings if they have permissions. When this option is disabled system-wide, it applies to all users.

*Automatic Save of Grid Settings.* Select if you want the system to automatically save grid settings and reload them the next time users access that function.

*Automatic Save of Last Used Browse Settings.* Select if you want the system to automatically save each user's last used browse and lookup settings and reload them the next time the user accesses that function.

When the Automatic Save of Last Used Browse Settings option is enabled, individual users can disable it in User Settings if they have permissions. When this option is disabled system-wide, it applies to all users.

**Note** If you clear the Automatic Save of Last Used Browse Settings field, changes to browse settings are not saved automatically. However, any changes you make to a browse before you clear the Automatic Save of Last Used Browse Settings field are saved. If you want to reset the browse settings to the factory default or customer default, use Stored Search Delete to delete user-level stored searches. Browse settings are also stored in memory cache; therefore, it is recommended that you log off the application and log on again after you make changes to the browse defaults.

*Business Logic Version Checking.* Select to ensure that all business components register their versions in the application database. When a component is activated, the system checks the client version against the server-side version registered in the database. Any inconsistencies are reported.

Enabling this setting can be useful in ensuring system integrity. For example, if you have multiple application servers, a patch may be installed on one server and not another. When the client runs the updated component, its version number is registered. Later, if the other server is used where the patch is not installed, the system detects that an older version of the component exists and displays an error preventing the component from being run.

*Draft Instances.* Select to enable the support of draft instances—records saved without validation—in all functions that support Save as Draft. If you clear the field, the Save as Draft and Browse Draft activities are disabled.

Currently, the Save as Draft feature applies only to the following functions:

- Banking Entry
- Business Relation
- Customer
- Customer Finance Charge
- Customer Invoice
- Journal Entry
- Petty Cash
- Supplier Invoice
- Supplier

*Field Security.* Select if you want to activate the ability to set permissions and access to individual fields in the UI. When this setting is selected, the Field Security Maintain activity displays on the menu; otherwise, it does not. For more information on field security, see [QAD Security and Controls User Guide](#).

*User Interface Customization.* Select to enable users with the relevant roles to customize the UI. See Chapter 12, “UI Customization,” on page 249.

This option is enabled by default. When this option is enabled, individual users can disable it in User Settings if they have permissions. When this option is disabled system-wide, it applies to all users.

**Important** This option also controls whether browse and grid savings can be saved. When this field is disabled, the browse and grid settings have no effect, since they are considered to be a form of UI customization.

*User-Defined Fields.* Select to enable users with access to customizing the UI to add user-defined fields (UDF) to customized activities. UDFs can only be added to the UI when the User Interface Customization field is selected.

*Workflow.* Select to enable ad-hoc workflow. When the field is cleared, the Workflow choice on the Tools menu of component activities is disabled.

Selecting this field is typically combined with selecting the Workflow Inbox. However, you can also notify the recipients of work items through e-mail rather than an application Inbox.

For more information on creating and receiving workflow items, see *Introduction to QAD Enterprise Applications User Guide*. See “Configuring Workflow” on page 159 for more details on setting up workflow.

Enabling workflow adds load to the system, which can degrade performance since the system must continually poll for new Inbox objects. To reduce this load, have users that will not be receiving objects in their Inbox disable the feature in User Settings.

*Automatic Save of Last Used Stored Search.* Select if you want the system to automatically remember the stored search that was last used in a browse and display it with this search loaded the next time the user accesses that function.

When this option is enabled, individual users can disable it in User Settings if they have permissions. When this option is disabled system-wide, it applies to all users.

*Enable Persistent Cache.* This option caches menu and browse settings from the current session and re-loads them in the next session. Caching stores static data on the client and improves performance. You can also set this option for individual users in Change User Settings (36.24.5.2). If set at the system level, the setting applies to all users. If not set at the system level, the individual user setting is enabled.

**Note** Use the Reset Client Cache (36.24.3.7) menu option to clear the persistent cache.

*Use Language Specific Object Description.* Select this option to display translated descriptions in the language associated with a user’s ID in User Maintenance, provided that descriptions are loaded or entered for this language. The Description fields for most component-based records support a translation option.

If you select the Use Language Specific Object Description field, the system also retrieves translated descriptions when the user runs API queries.

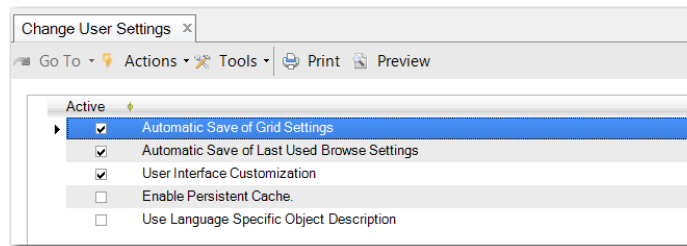
If you clear this field, this option is disabled in Change User Settings. If the Use Language Specific Object Description system setting is selected, the corresponding user setting is selected by default, but you can clear the setting in Change User Settings.

## User Settings

The User Settings function lets each user configure a subset of settings that are defined at the system level. The settings are effective for the current user only. Users can only modify these settings if they have been enabled system wide.

Disabling UI Customization can enhance performance for a user.

**Fig. 6.11**  
Change User Settings, (36.24.5.2)



## Field Descriptions

Each user can modify a subset of the system settings when they are enabled:

*Automatic Save of Last Used Browse Settings.* See “Automatic Save of Last Used Browse Settings” on page 155.

*Automatic Save of Grid Settings.* See “Automatic Save of Grid Settings” on page 155.

*Use Language Specific Object Description.* See “Use Language Specific Object Description” on page 157.

*User Interface Customization.* See “User Interface Customization” on page 156.

*Enable Persistent Cache.* See “System Settings” on page 154.

## Making UI Caching Configurable

You can configure the system to prevent the UI from automatically caching the result of method calls that are executed in the business logic to retrieve metadata for screens and browses. It may be important to suppress caching in some situations; for example, if a method is customized, and does not return the same data in all cases.

You can suppress automatic caching using the `CachingExceptions` setting in the `client-session.xml` template, and `homeserver.config.template`. Typically, the `CachingExceptions` setting contains a list of components or query names that are normally included in the cache. You can then use the `CachingExceptions` setting to indicate that the system must suppress caching for calls to a particular component or query. For example, the following setting suppresses caching for all method calls and query calls to the component `BSaf`, and for the query `BGL.SelectGL`:

```
CachingExceptions = "BSaf,BGL.SelectGL".
```

The `CachingExceptions` setting is processed by the code that implements the caching mechanism. If the `CachingExceptions` setting applies for a particular component or query, the system does not write data to the cache for that query or methods called on that component.

The next time the method for the component or the query is run, the cache will be empty, and this forces the method or query to be re-executed.

## Configuring Workflow

The embedded internal workflow lets users forward or route work items to another role or person in the organization for completion or validation. It serves as a built-in automated approval process that can be applied to any record or document created in the system by forwarding work to the appropriate role. It must be specifically enabled before it can be used.

The workflow is a generic function that can be started from the Tools menu of an individual screen. The user must have a role that has been given access to create workflows in Role Permissions Maintain (36.3.6.5) in order to initiate a workflow.

Workflow is also used with the Scan daemon. See for details.

The record attached to the workflow is assigned to a role. All users that belong to that role receive a notification as an entry in their Inbox. Optionally, when the E-mail Notification check box is selected, users also receive an e-mail notification. The e-mail address is taken from the user record in User Maintenance (36.3.1).

You can display the Workflow Inbox as follows:

- 1 In Change System Settings, select the Workflow field. See “System Settings” on page 154.
- 2 Log off from the QAD application; shut down the AppServer.
- 3 Restart the AppServer.
- 4 Log in to your QAD application.

An Inbox icon should now display in the upper-right area of the screen. Roll your cursor over the icon to display the contents; click the icon to open the Inbox.

A system administrator can monitor workflow objects that have been created and never acted on. In some circumstances these objects may need to be removed from the system, for example, when an employee has left the company.

## Managing Draft Objects

Enabling the Save as Draft and Browse Drafts options in Change System Settings lets users create draft instances of a subset of components.

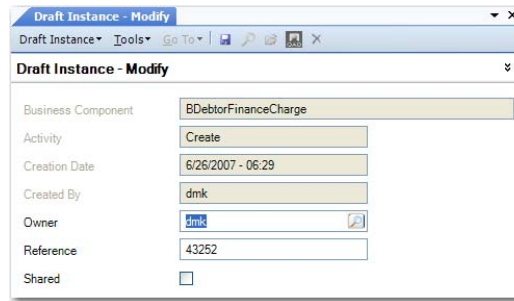
System administrators may need to monitor these draft records to ensure that none are left unattended in the system.

You can use the Draft Object activities (36.24.9) to view, modify, delete, or complete draft objects.

When you modify a draft object, you can assign it to a new owner, change the name by which it is referenced, or modify whether the object can be viewed by others.

After selecting an object in the view, choose Modify from the right-click menu.

**Fig. 6.12**  
Draft Object Modify (36.24.9.3)



Draft Instance - Modify	
Business Component	BDebtorFinanceCharge
Activity	Create
Creation Date	6/26/2007 - 06:29
Created By	dmk
Owner	dmk
Reference	43252
Shared	<input type="checkbox"/>

*Owner.* Specify a new owner for this draft instance if needed. The new owner can modify and complete the draft instance.

*Reference.* Modify the name of the draft instance if needed.

*Shared.* Select this field if you want this draft instance to be visible to others.

# CIM Interface

This chapter describes how to use database utilities to manage the movement and storage of data in a database.

***Introduction to CIM* 162**

Explains how CIM is used.

***Using the CIM Interface* 162**

Explains the CIM data load and format, and describes the input file formatting rules, input data types, and data for the input file. Gives a CIM data input file example, and discusses creating a CIM input file and error handling.

***Deleting Records through CIM* 168**

Explains how to create input files to delete records and gives an example of CIM delete.

***Running Multiple CIM Sessions* 169**

Explains how to run multiple sessions.

***Killing CIM Sessions* 169**

Explains the best way to stop a CIM session.

## Introduction to CIM

Transferring data can save disk space, increase disk access speeds by compacting fragmented data, and integrate legacy or otherwise noncompatible data with QAD data. There are three basic ways to transfer data into and out of your QAD database:

- Dump or load data files.
- Archive and delete or reload data files.
- CIM load data files.

The first two options are discussed in Chapter 8. This chapter discusses CIM data load, which lets you load data into your QAD database from any source, as long as the data is formatted to match the QAD database schema. See page 171.

CIM is typically used to add or modify records in a database. In certain cases, it can also be used to delete records. Only some functions support this feature. See “Deleting Records through CIM” on page 168.

Unlike direct data loads, CIM checks load data for errors and saves unloaded records in an error file for correction and reloading. CIM loads can be run in either batch or continuous mode.

**Note** CIM must be executed against character-based programs; it is not supported in the QAD .NET UI. Additionally, component-based functions in the .NET UI offer different integration approaches, such as Excel integration, along with the XML and Event daemons.

## Using the CIM Interface

The CIM interface loads data through online maintenance programs. All data validation used in these programs during normal data entry is available during a CIM load. Imported data is then made available to other programs.

Most of the data loaded through CIM is loaded into a specific domain. The domain used is the one the user executing the CIM function is currently logged into. If you have access to multiple domains, make sure you are logged into the correct one before beginning the load.

In UNIX, you can use an external load program to load data continuously. These programs can accept input from devices such as barcode readers.

If data is loaded directly into tables using dump/load programs or Progress loads, some tables may not be updated correctly.

Load data into your QAD database using functions on the CIM Interface Menu (36.15). Imported data can come from:

- Any ASCII file that follows the correct conventions.
- The output of programs that run in multiprocessing environments such as UNIX.

See “CIM Data Format” on page 164.

To load a product structure, for example, construct a file that matches the record structure in the product structure master (ps\_mstr), then load data into that table. The CIM interface enables you to construct a file of input values for Product Structure Maintenance (13.5), and then validates all the data.

Internally, the CIM Interface operates in two stages:

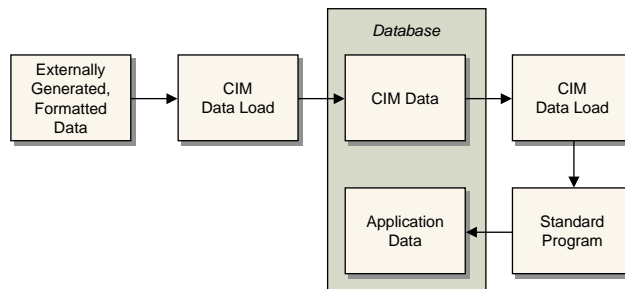
- 1 CIM Data Load (36.15.1) loads the external data you specify into batch load data tables (bdl\_mstr and bdl\_det) in the database.
- 2 CIM Data Load Processor (36.15.2) sends data stored in CIM database tables through the appropriate input screen.

Both the data load and the data processor can be executed as a Progress background session.

Use other functions on the CIM menu to:

- Use CIM Data Load Process Monitor to monitor the load process, as needed.
- Use CIM Data Load Report/Delete to review processing errors and delete processed data, as needed.

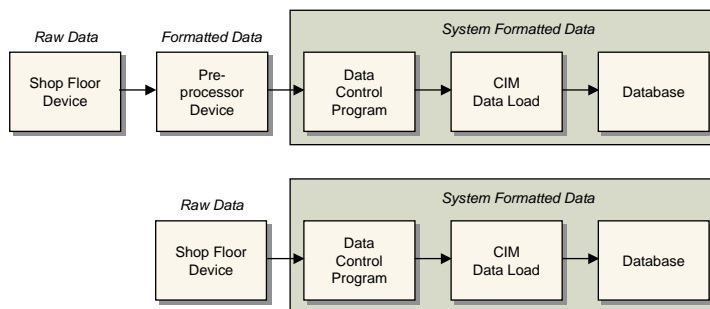
**Fig. 7.1**  
CIM Data Load



When CIM Data Load reads a data load group, it creates a record in the batch data load master table and assigns it a unique group ID. This integer record contains the name of the program to receive the data, and the date and time when the record was added. CIM Data Load then creates a record in the batch load detail table for each line of input data from the data load group. See “CIM Data Format” on page 164 for details.

Input from a file can be from either a disk file or a device-character file such as a serial port. If Input File/Continuous Process is selected, CIM Data Load executes the external program named in the Continuous Process Name field. The program controls and formats incoming data and sends its output back to CIM Data Load.

**Fig. 7.2**  
Continuous Data Input



**Warning** When acquiring external data in real time, run CIM Data Load at the highest possible dispatch priority to ensure that data loss does not occur as a result of competition with other system processes.

## CIM Data Format

Each program takes in data in groups. A group typically consists of input fields within a frame. When using a program interactively, you must click Next to move from one group to another. See “Determining Data for the Input File” on page 165.

Data going into the CIM load must use the rules described in this section.

The `@@BATCHLOAD` key word signals the beginning of the data-load group, consisting of one or more lines. Program name is the system program that will process the input data. For example, if item data is being loaded, the program name would be `ppptmt04.p` (Item Data Maintenance, 1.4.3). See “CIM Data Input File Example” on page 166.

All input data contained between each `@@BATCHLOAD` and `@@END` is one group, regardless of how many transactions are specified in the data section.

Limit the number of transactions to 50. Each transaction entry can involve the creation of many records. The more transactions in a transaction group, the more system resources are required for processing, and the greater the likelihood of errors.

An error in one transaction can put all transactions in a group out of sequence and prevent the system from processing that group. In cases where maintaining data integrity is vital and re-creating data difficult, you might limit the number of transactions to one.

## Input File Formatting Rules

When creating your CIM input file, follow these formatting rules:

- Use a single line of data for each input request.
- To treat two consecutive input lines as a single line, place a tilde (~) at the end of the first line. The tilde (~) is not required if you create the CIM file in an editor. Place no characters, including spaces, after the tilde.
- Surround character fields with quotation marks.
- At the end of each input group, use a line feed. The end of an input line performs the same function as clicking Next (F1 in character UI). Fields for which there are no data and that come at the end of an input sequence do not require hyphens.
- Type all characters in lowercase, taking care to spell correctly.
- Use a hyphen (-) to Tab through a field, retaining the default or existing value. For example, to accept default data for fields 1, 2, 3, 5, and 7, and enter Yes, 12, and 01/01/02 for fields 4, 6, and 8, enter the following:

```
--- "yes" - "12" - "01/01/02"
```

- Format data as it is entered.
- Use a period on a line by itself to indicate End or End-Error.  
For repeated input (that is, multilevel), use the period to go back one level. This executes the End command.
- Use slashes (/) where needed. These are not required.
- Make sure the date format in the CIM file matches the date format specified in the Progress session startup parameters (-d parameter).
- Use a caret (^) to indicate a null value.

## Input Data Types

Input data is information that you would normally enter from your terminal. The manner in which you enter information in an input file depends on the type of information the field is set up to handle. There are four types of input data:

- Character fields can be alphabetic or numeric but have no mathematical operations applied to them. Descriptions (alphabetic) and customer codes (numeric) are examples of character fields. Surround descriptions with double quotation marks (“ ”). The description is accepted without quotation marks, but may be interpreted as more than one input. If there is a space in the description, you must use quotation marks.
- Fields used in mathematical operations are numeric values. They can contain a decimal point (.) or a negative sign (–), but no other symbols, including commas (,) and dollar signs (\$) are allowed. Do not use quotation marks for numeric values.
- Logical fields use Yes/No values and do not require quotation marks.
- Format date fields the way they are formatted in the source field.

## Determining Data for the Input File

Each program contains one or more entry groups. Each entry group consists of one or more data entry fields in which data can be entered before clicking Next.

**Example** In Site Maintenance (1.1.13) there are four entry groups, corresponding to the number of times you must click Next. Although direct correspondence between entry groups and frames is normal, it is not required. The four entry groups are:

- Key field group—site code
- Site data
- Selection option
- Domain data

Each entry group corresponds to one line in a CIM file.

While navigating a program to determine field groupings, use the Tab key to move from field to field, rather than the Return key. The Return key works like the Tab key in all fields except the last field in an entry group, where it executes the Next command. This can be misleading in determining which fields belong to an entry group.

## CIM Data Input File Example

```

/* wocimp.p */
/* Program to create CIM input data file for Work Order Receipt Backflush */
DEFINE VARIABLE wonbr LIKE wo_nbr.
DEFINE VARIABLE wolot LIKE wo_lot.
DEFINE VARIABLE woqty LIKE wo_qty_comp.
DEFINE VARIABLE woyes AS LOGICAL INITIAL yes.
DEFINE VARIABLE wono AS LOGICAL INITIAL no.
DEFINE STREAM bf.
OUTPUT STREAM bf TO batchloa.d.
REPEAT:
    PROMPT FOR wonbr wolot woqty.
    wonbr = INPUT wonbr.
    wolot = INPUT wolot.
    woqty = INPUT woqty.
    /* See if work order exists in system. */
    FIND FIRST wo_mstr WHERE wo_nbr=wonbr AND wo_lot= wolot NO-LOCK NO-ERROR.
    IF AVAILABLE wo_mstr THEN DO:
        /*Identify beginning of record & program used.*/
        PUT STREAM bf "@@batchload wowoisrc.p" SKIP.
        /*The work order number and ID.*/
        EXPORT STREAM bf wonbr wolot.
        /*qty comp., issue alloc=yes, issue pick=yes*/
        EXPORT STREAM bf woqty woyes woyes.
        /*Component issue - yes.*/
        PUT STREAM bf "." SKIP.
        /*Display items being issued - no.*/
        PUT STREAM bf ".".
        /*Is all information correct - yes. */
        EXPORT STREAM bf woyes.
        /* Qty complete. */
        EXPORT STREAM bf woqty.
        /* Remarks - no. */
        PUT STREAM bf "-" SKIP.
        /*Display item and lot/serial detail - no. */
        EXPORT STREAM bf wono.
        /*Is all information correct - yes. */
        EXPORT STREAM bf woyes.
        /* Please confirm update - yes. */
        EXPORT STREAM bf woyes.
        /* Identify end of record. */
        PUT STREAM bf "@@end" SKIP.
    END.
END.
OUTPUT STREAM bf CLOSE.

```

## Creating a CIM Input File

To create a data input file, first determine the program to be used and fields to be updated. The basic steps are as follows:

- 1 Run the program that is to receive the data and determine the program name. You can also run Menu System Report (36.4.4.2).
  - a In the character interface, use the Ctrl+F key combination to display the program context, including name.
  - b In the .NET UI, right-click on the option in the menus and choose Properties to display program details.
- 2 Determine the program's key fields. These are typically the first fields, and always let you advance to the next field by pressing Next.

A good test is to position the cursor in a field, and click Next. Note where the cursor goes. Reposition the cursor in the field, and press Return. If the cursor moves to the same place as it did when using Next, embed Next (Carriage Return) in your CIM file. If the cursor went elsewhere, embed a Return. You could still embed Next if this new cursor position did not lead to any field you want to populate.

An input file must contain values for key fields, each on a line by itself. This allows the Next command to apply to the appropriate field.

Note which fields are validated or secured. Do this by typing any character (for example, x) and pressing Enter. If a warning displays, the field is validated or otherwise constrained. Your input file must conform to valid choices for the field. Use the lookup/browse for a list of valid entries.

- 3 Choose non-key fields you want to populate and in what sequence. Note whether Next or Return is required after each entry.

Not all fields have labels. For example, a two-line description can consist of two separate fields. To determine which lines correspond to which fields, place the cursor in each line and press Ctrl+F to display their field names. You must populate each field with a separate entry in a CIM file.

**Note** In the QAD .NET UI, field names display as field tips.

- 4 Record a template of the CIM input file entries for the first frame.

The following is an example template for Item Master Maintenance (1.4.1):

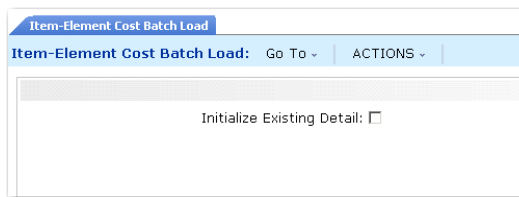
```
@@BATCHLOAD ppptmt04.p
"10-10000"
"EA" "Oasis Cooling System" "Home/Indust Model"
```

Remember, all CIM files start with @@BATCHLOAD <Program Name>. The Item Number (10-10000) is a key field and is required. It must be on its own line. The second line represents the next three fields in the entry group.

Follow Item Number with Next. The next line fills in the UM and Description fields. Note that Description is shown as two entries, one populating the first line, one populating the second.

**Note** There are a few cases where CIM load does not work, such as costing data in Item Master Maintenance (1.4.1). In this case, costing data has to be CIM loaded through Item Element Cost Batch Load (1.4.15); see Figure 7.3.

**Fig. 7.3**  
Item Element Cost Batch Load (1.4.15)



Use the following code to load this data.

```
@@batchload ppptmt04.p
"10-10000"
"Ea" "Oasis(TM) Cooling System" "Home/Indust Model"
"1000" "5/28/1992" "Config" "AC" "DISCRETE" "10-10000" "AB"
.
@@end
```

## Error Handling

When the CIM load is completed, CIM Data Load Processor (36.15.2) creates a report showing the groups successfully processed and any processing errors. Groups containing an error are not processed. Troubleshoot errors using the following guidelines:

- Are the values appropriate?
- Is there a line reading: @@batchload?
- Is there a line reading: @@end?
- Are the data in the correct order?
- Are there any blank lines?
- Are there any misplaced spaces?
- Is there an end-of-line for each data set?
- Does it complete the record?
- Did the first error cause all the others?

## Deleting Records through CIM

You can use CIM to delete records created with any of the programs listed in Table 7.1. In each of these programs, an updateable, single-character field, `batchdelete`, exists at the end of the header- and detail-record key frames. This field can be updated only when the program is accessed through a batch process, that is, when `batchrun = true`.

**Note** In the character UI, when you press Ctrl+F in a field of a program with `batchdelete` enabled, a pop-up window appears, indicating that you can use batch delete.

**Table 7.1**  
Programs with `batchdelete` Functionality

Menu Label	Program Name
Customer Item Maintenance	ppcpmt.p
Generalized Codes Maintenance	mgcodemt.p
Site Maintenance	icsimt.p
Price List Maintenance	pppimt.p
Price List Maintenance	pppcmt.p
Item Master Maintenance	ppptmt.p
Installed Base Item Maintenance	fsisbmt.p

Because the `batchdelete` value exists at the end of key frames, it does not affect existing CIM input files and can be omitted from these files when not used. Since it is only one character, unlabeled, and hidden, the field also does not change the visible interface.

## Creating Input Files to Delete Records

Use these guidelines when creating input files that include deletes:

- 1 To determine if `batchdelete` is enabled in a particular program, check the list in Table 7.1.
- 2 To invoke the batch delete functionality, place an `x` at the end of the header- or detail-record key frame line in the input file.
- 3 Follow the key frame with a blank line consisting of a single hyphen so that the program executes the code that would be executed if an F5 or Ctrl+D has been pressed in the first frame after the key frame.
- 4 Enter a subsequent line containing the string `yes` as an answer to the Please Confirm Delete prompt displayed for online deletes.

## Example of CIM Delete

This sample CIM input file deletes a Site Maintenance record:

```
@@BATCHLOAD icsimt.p
mysite
--
x
-
yes
@@END
```

## Clearing a Field Value

To blank out an input string using CIM load, you can place the empty string in the input file as two quotation marks (“”) at the correct position in the line. If the field is not a string, specify another value appropriate for the data type such as 0 for a number or a high date (in the year 9999, for example) for a date type field.

## Running Multiple CIM Sessions

Any number of CIM sessions can be run at one time. However, two load sessions cannot be opened for a single file. To run two sessions, divide the file.

When running multiple sessions, use CIM Data Load Process Monitor (36.15.4). The monitor shows the state of all existing CIM sessions. Type and Process Session are indexes to the sessions. Enter Process in Type and use (/) to first see all the Process sessions, followed by the Load sessions. If you select Next at the Session field, the current status of the processes displays continuously. The display shows startup time, last transaction time, and selection criteria used when the session was started.

## Killing CIM Sessions

Although a CIM session runs under the operating system and can be stopped using operating system commands, this is not advised. When the operating system kills a session, your QAD application is not notified and a record of the session may still display in the CIM Data Load Process Monitor (36.15.4).

The best way to kill a CIM session is to use the Process Monitor. To kill a session, identify the session using the Type and Session fields then press the F5 key in the Session field. A prompt asks you to confirm that you want to delete this record.

If the session was invoked with a low-dispatch priority, your monitor may still display a session after it has been stopped, with a status of Killed. To erase the session from the system, delete it again by putting the cursor on the Session field and pressing F5.

# Database Management

This material covers utilities for monitoring database size, performing dumps and loads, reloading archive files, managing database sequences, registering applications, and monitoring license compliance.

***Managing Database Size* 172**

Explains how to determine disk usage and free disk space.

***Dumping and Loading Data* 173**

Discusses dump/load procedures.

***Deleting and Archiving Data* 174**

Lists transactions that can be deleted or archived. Provides information on GL Audit Detail Delete/Archive and on restoring archive files.

***Integrity Logging* 179**

Explains how to use the Corrupt Logging function.

***Registering Licenses* 180**

Gives a licensing overview; explains how to use License Registration and run license reporting.

***Managing Database Sequences* 190**

Explains how to initialize sequences, maintain sequences manually, maintain sequences using CIM, maintain audit trails, and maintain sequences in Oracle.

***Component Record Numbering* 194**

Explains how to use Record Number Maintain.

***Setting Up Multiple Time Zones* 196**

Explains how to use Multiple Time Zones Maintenance, use Multiple Time Zone Load Utility, and set a default time zone.

## Managing Database Size

You can use system utilities for managing the size of your database.

### Determining Disk Usage

Use Database Table Size Inquiry (36.16.1) to dump selected tables and review their sizes. The program requires adequate free disk space to run. Reported table sizes may be understated since indexing overhead is not taken into account.

Use Disk Space Inquiry (36.22.13) to display free space for each available disk, in blocks. For most UNIX environments, a block is typically 1024 bytes. For Windows environments, blocks range from 1024 to 8192 bytes. Consult your hardware manuals for exact specifications.

**Note** These programs must be run from a character user interface.

**Fig. 8.1**  
Disk Space Inquiry (36.22.13)

/	(/dev/vx/dsk/rootvol):	956656 blocks	464665 files
/proc	(/proc	):	0 blocks 4453 files
/dev/fd	(fd	):	0 blocks 0 files
/tmp	(swap	):	7823264 blocks 381700 files
/opt2	(/dev/vx/dsk/crsu03_dg/vol04):	2757000 blocks	948168 files
/dr01	(/dev/vx/dsk/crsu03_dg/vol01):	46291736 blocks	12355240 files
/dr02	(/dev/vx/dsk/crsu03_dg/vol02):	48571390 blocks	12427225 files
/dr03	(/dev/vx/dsk/crsu03_dg/vol05):	9841572 blocks	2461436 files
/opt.new	(/dev/vx/dsk/crsu03_dg/vol03):	8622328 blocks	2448537 files
/users/cmb	(qcrhp01:/disks/drive2/d7/users/cmb):	654480 blocks	-1 files
/users/dzn	(qcrhp06:/dr4/users/dzn):	422860 blocks	-1 files
/users/svc	(ohhp04:/home/u3/svc):	1401846 blocks	-1 files
/users/fxd	(ohhp04:/home/u3/fxd):	1401846 blocks	-1 files
/users/pzd	(ohhp04:/home/u3/pzd):	1401846 blocks	-1 files
/users/byd	(qcrhp01:/disks/drive2/d7/users/byd):	654480 blocks	-1 files
/users/rbe	(qcrhp01:/disks/drive2/d7/users/rbe):	654480 blocks	-1 files
/qad/mfgpro/85db/etfdb	(ohhp40:/dr01/85db/etfdb):	9285970 blocks	-1 files
/users/svb	(ohhp04:/home/u3/svb):	1401846 blocks	-1 files
/users/ncr	(ohhp04:/home/u3/ncr):	1401846 blocks	-1 files
/users/scq	(qcrhp06:/dr5/users/scq):	3373932 blocks	-1 files

### Freeing Disk Space

There are three ways to reduce the size of a Progress database:

- Use dump/load programs to compact your data. Compacting data can increase disk access speeds significantly. To do this, dump all data from your database, and reload it into an empty database. You need free disk space amounting to about 70% of the total size of your data (.d) files. Progress recommends that you dump/load once a year.
- Use delete/archive programs to create free database space. Typically, the largest tables in a database contain history, sales order, and purchase order data. The amount of disk space may decrease if you store the archived data on the same disk. See “Deleting and Archiving Data” on page 174.
- Use both dump/load and archive/delete programs. To do this, remove records from the database, dump the remaining data, and reload it into an empty database. You need plenty of free disk space to do this.

## Dumping and Loading Data

Dump/load programs move the contents of database tables into or out of ASCII files. The dump procedure reads a database table, puts quotation marks around the data value of each field, and places those values in an ASCII file.

**Example** A record in the user master table (usr\_mstr) consists of the following entries:

```
usr_lang      FR
usr_site      1000
usr_user1
usr_user2
usr_user      pxr
```

One line in the dump file would read:

```
"FR" "1000" "" "pxr"
```

You can use dump files as input to other programs after converting the files to CIM input-file format. You can also take output from other programs, convert it to CIM input-file format, and load it into the database. This assumes the data has the correct form, based on the screen flow and format the CIM input is duplicating. The *Database Definitions* book contains details on specific table formats. See “Using the CIM Interface” on page 162 for details.

Dump/load procedures are located at 36.16.4 for Windows clients and at 36.16.3 for UNIX environments. Load procedures do not overwrite existing records. You must delete the old data first.

**Note** Progress and Oracle each provide dump/load and import/export programs, but these programs do not maintain the integrity of data in the QAD database. See the Progress user manuals.

### Dump/Load Procedures

To dump/load data:

- 1 Back up the existing database.
- 2 Check available disk space. A full dump/load requires free space equaling approximately 70% of existing database size. See “Determining Disk Usage” on page 172.
- 3 Log in to your QAD system in single-user mode. You can speed up the dump/load by running multiple sessions of Database Table Dump/Load from multiple terminals.
- 4 Execute Database Table Dump/Load for the correct range of tables.  
If there is enough free space, select all tables. If there is not, archive the dumped files to a tape, then erase them from the database. Repeat this step as needed.
- 5 When the dump is finished, copy the standard, empty QAD database (mfg) onto your old database.
- 6 Load the dumped files back into the database using Database Table Dump/Load.

Data files (.d files) reloaded into databases containing data do not overwrite existing records. Files to be loaded must be in a directory specified in your PROPATH. A Progress bulk load is usually faster than a dump/load, but can require an index rebuild.

The system lists load errors in a .e file located in the directory you ran the process from.

## Deleting and Archiving Data

Delete/archive programs remove selected records from the database, letting you archive them to tape or other media. Each delete/archive screen looks similar to a report criteria input screen. You choose records based on selection criteria. Criteria can include date ranges, document numbers, employee names, and so on.

Table 8.1 lists data that can be deleted and archived.

**Table 8.1**

Transactions that Can Be Deleted/Archived

Audit Detail	Bulk Pick History	Call/Quote History
Closed Cumulative Orders	Closed Intersite Demand	Closed PO Shippers
Closed Projects	Closed Purchase Orders	Closed Purchase Receipts
Closed Purchase Requisitions	Closed Service Requests	Comment Cross-References
Containers	Contract Revenue	Contracts
Correction Invoices	Cumulative Orders	Customer Schedules
Deferred/Accrued Revenue	Detail Forecasts	Distribution Order Shippers
Electronic Sig Failures	Electronic Signatures	Empty Bulk Picks
Engine History	Expired Call Quotes	Expired Sales Quotes
Expired Warehouse Holds	Family Hierarchies	Field Notifications
Flow Schedules	GL Transactions	Inbound EDI Documents
Inspection History	Installed Base History	Intersite Requests
Intrastat History	Inventory Consumption	Inventory Transactions
Inventory Transactions	Invoice History	Kanban Transactions
Logistics Charges	Logon History	Lot Masters
Master Bills of Lading	Operation History	Operation Plan Simulations
Operation Plans	Outbound EDI Documents	Pending Calls
Performance Data	Physical Inventory Tags	Product Change Orders
Product Change Requests	Product Structures	Purchase Order Shippers
Q/LinQ Documents	Quality Orders	Quality Test Results
Requisitions	Retired Fixed Assets	Routings
Sales Analysis	Sales Order Shippers	Self Bills
Sequence (NRM)	Service Contracts	Service Requests
Service/Repair Orders	Shippers	Subcontract Shippers
Supplier Performance Data	Supplier Schedules	Tracked Documents
Transaction History	Turnaround Data	Uninvoiced Receipts

Verbosity Data                      WIP Lots                      Work Orders  
 Zero Inventory Balances      Operational Journal Entry

## GL Audit Detail Delete/Archive

Use GL Audit Detail Delete/Archive (36.23.1) to delete/archive audit detail information. Unlike other delete/archive programs, this program does not delete each record specified. Instead, for each unique combination of user ID, table, and field, it keeps the latest record and deletes/archives the rest.

To delete and/or archive tables:

- 1 Back up your database and .df files.
- 1 To safeguard against data archived from a previous product version that has different schema, back up the current database definitions (.df) file with each archive/delete run. This lets you reconstruct a corresponding database for data retrieval.
- 2 Verify record selection.  
 Run the delete/archive program without deleting or archiving records. This generates a report showing selected records. Review the report and if records selected for deletion are correct, proceed with the actual archive/delete.
- 3 Run appropriate historical reports such as Invoice History Delete/Archive (7.13.23).
- 4 Determine selection criteria for the records being deleted, and run the delete/archive program, selecting both Delete and Archive.  
 The program creates a `xxyyymmdd.hst` file in the default directory where `xx` is the record identifier, such as `iv` for invoices and `yymmdd` is the archive date.
- 5 Verify deletion of records from the database.
- 6 Verify the contents of the .hst file using the appropriate operating system command.
- 7 Back up the .hst file to storage media and delete from system.  
 The delete/archive program does not reduce database size. To reduce database size, use a dump/load program.

## GL Transaction Delete/Archive

General ledger transactions created in operational functions such as purchasing, inventory control, manufacturing, and fixed assets are stored in the unposted transaction table until they are posted. Review unposted transactions using Unposted Transaction Inquiry (25.13.13).

Use GL Transaction Delete/Archive (36.23.2) to delete and archive unposted transactions created in modules other than General Ledger.

**Note** GL transactions are stored in the unposted transaction table until they are posted. Unposted transactions can be reviewed using Unposted Transaction Inquiry.

Use GL Transaction Delete/Archive in two specific situations:

- You are not using QAD Financials.

- You implemented other modules prior to implementing Financials. Before implementing General Ledger, delete the GL transactions in the unposted transaction table since these are already reflected in the beginning balances you enter.

**Important** For a standard implementation, GL Transaction Delete/Archive is used only during early stages of implementation. After transactions of a particular type (PO, IC, WO, or FA) have been posted to the general ledger, no further transactions of that type can be deleted or reloaded.

You should run this function twice. First, run it with Delete set to No and review the report. Then, run it with Delete set to Yes.

When you set Delete to Yes, GL transactions that satisfy the selection criteria are deleted from the database. If you set Archive to Yes, deleted data are copied to an ASCII file that can be reloaded using Archive File Reload. Otherwise, deleted data cannot be recovered.

When Archive is Yes, selected data is stored in a file named glYYMMDD.hst, where gl is the record type and YYMMDD is the file creation date. If this file does not exist in the system, it is created. If it does exist because you already ran delete/archive the same day, the system adds the additional archived records to the end of the file.

Since the generated file has no internal label or content description, you should keep a record of the file name and contents, in case you need to reload the data. Also, remember that you cannot selectively reload data from archive files. If an archive file contains data for an entire year and you need to access records for one month, you must reload all the data in the file to access the records you need.

**Important** Date and time in the stored data are formatted based on the country code associated with the user who archived the data. If a user with a different date and time format reloads the data, load errors and corrupted data can occur.

To avoid these problems, use the same settings when archiving and reloading the data. Before loading data, use User Maintenance to temporarily change your country code to match that of the user who archived the data.

You should define menu security for this program.

**Fig. 8.2**  
GL Transaction Delete/Archive (36.23.2)

## Logon History Archive/Delete

Use Logon History Archive/Delete (36.23.3) to delete and archive login history records when online history is no longer needed.

The system does not automatically delete historical information at period or year end. You can delete this information as frequently or infrequently as you prefer. How often you should run this function depends on how long you need to retain historical information in your database. Most companies keep historical data for at least one year or longer, depending on availability of disk space.

You should run this function twice. First, run it with Delete set to No and review the report. Then, run it with Delete set to Yes.

When you set Delete to Yes, login history records that satisfy the selection criteria are deleted from the database. If you set Archive to Yes, deleted data are copied to an ASCII file that can be reloaded using Archive File Reload. Otherwise, deleted data cannot be recovered.

**Important** You cannot set Archive to Yes when Delete is No.

When Archive is Yes, selected data is stored in a file named uslhYYMMDD.hst, where uslh is the record type and YYMMDD is the file creation date. If this file does not exist in the system, it is created. If it does exist because you already ran delete/archive the same day, the system adds the additional archived records to the end of the file.

Since the generated file has no internal label or content description, you should keep a record of the file name and contents, in case you need to reload the data. Also, remember that you cannot selectively reload data from archive files. If an archive file contains data for an entire year and you need to access records for one month, you must reload all the data in the file to access the records you need.

**Important** Date and time in the stored data are formatted based on the country code associated with the user who archived the data. If a user with a different date and time format reloads the data, load errors and corrupted data can occur.

To avoid these problems, use the same settings when archiving and reloading the data. Before loading data, use User Maintenance to temporarily change your country code to match that of the user who archived the data.

You should define menu security for this program to restrict access.

**Fig. 8.3**  
Logon History Archive/Delete (36.23.3)

*Date.* Enter a range of log on dates to select history records to delete or archive.

*Archive.* Indicate whether to archive the selected records.

No: The selected records are not copied to an ASCII file.

Yes: The selected records are copied to an ASCII file. The system creates a file name in the following format: xxYYMMDD.hst, where xx identifies the module code or record type and YYMMDD is the file creation date. If this file does not exist, it is created. If it does exist, records are appended to the end.

*Delete.* Indicate whether to delete the selected records or generate a report only.

No: The selected records are not deleted. A report is generated listing the selected records.

Yes: The selected records are deleted from your database and listed in a report.

If you set Archive to Yes when Delete is Yes, the selected records are copied to an ASCII file before deletion. Use Archive File Reload to reload the data, if needed. See “Restoring Archive Files”.

## Restoring Archive Files

Use Archive File Reload (36.16.5) to reload an archive file after restoring the file from backup media to the system disk.

**Fig. 8.4**  
Archive File Reload (36.16.5)

The reload process puts data from the archive file back into the database exactly as it was when you deleted it. However, if base data has changed, you may encounter errors.

**Example** You are reloading accounts receivable history for a customer that has been deleted.

Select Allow Errors to continue processing when errors occur. The system lists load errors in a .e file located in the directory you ran the process from.

**Important** Date and time in the stored data are formatted based on the country code associated with the user who archived the data. If a user with a different date and time format reloads the data, load errors and corrupted data can occur.

To avoid these problems, use the same user settings when archiving and reloading the data. Before loading data, use User Maintenance (36.3.1) to temporarily change your country code to match that of the user who archived the data. For more information on User Maintenance, see [QAD Security and Controls User Guide](#).

## Journal Entry Archiving

The journal entry archiving functionality enables you to summarize and archive operational journal entries from past years. The basic steps are:

- 1 Complete data archive configuration.
- 2 Create an archive task code where you can specify an entity group.
- 3 Run an estimate report to view a simulated result, such as the number of records to be archived and the space to be freed up.
- 4 Run the archive action to create an archive file in a predefined file location.
- 5 After the archive file is generated, run the summarize action to summarize the archived journal entries. The system removes the original journal entries from the database and creates new summarized journal entries to keep the account balance.
- 6 When needed, restore the archive file to the system. The system removes the summarized journal entries and reloads the original journal entries.

The following programs enable you to configure and perform the archiving task:

- Data Archive (36.23.4.1)
- Archive Configuration Maintenance (36.23.4.2)
- Archive Task Maintenance (36.23.4.3)
- Financial Archive File Reload (36.23.4.4)
- Data Re-Archive Utility (36.23.4.5)
- Archive Audit Trail Report (36.23.4.6)

For details of this functionality, see *QAD Financials User Guide*.

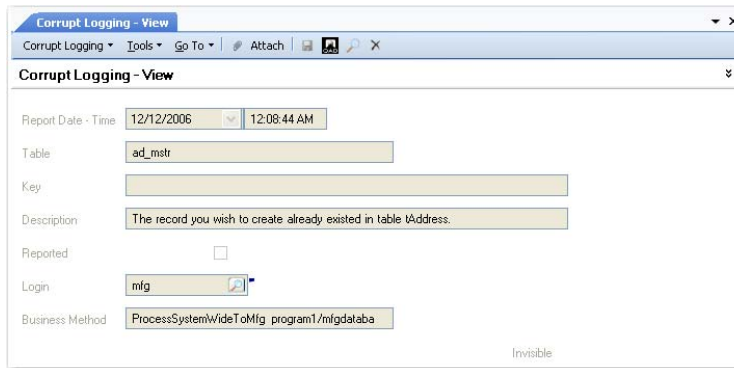
## Integrity Logging

The Corrupt Logging function identifies referential integrity problems in the database tables related to component activities, and stores results in a file.

Corrupt Logging Maintenance (36.16.7) has the following activities:

- Mark as Reported: Marks the list of current logs as reported. Previously reported logs are not displayed the next time.
- View: Displays the current list of corrupt logs. Select a row to display detailed information on the log.
- Delete: Clears the logs.

**Fig. 8.5**  
Corrupt Logging, View (36.16.7.1)



### Field Descriptions

*Report Date-Time.* Displays the date and time at which the error was detected.

*Table.* Displays the name of the table in which the error occurred.

*Key.* Displays the key field of the record that must be corrected.

*Description.* Displays a description of the error.

*Reported.* Indicates whether the error or issue has previously been marked as reported.

*Login.* Displays the ID of the user who encountered or generated the error.

*Business Method.* Displays the business component method in which the error occurred.

## Registering Licenses

When you receive your QAD software, you also receive license codes for the foundation product and other separately licensed applications.

The license codes identify the license type, version, expiration date and number of days remaining, and number of users, sessions, or transactions for which your site is licensed. Before you can use the system, you must register the license codes.

License registration programs are provided under the License Registration menu (36.16.10). Use the license registration programs to:

- Register newly installed software.
- Upgrade software to add new users or sessions.
- Maintain and report historical license data.
- Report detailed and summary license violations.
- Report license usage and user activity for QAD-conducted audits.

### Licensing Overview

QAD licenses software to its customers for use by a predetermined number of users, sessions, or transactions.

The following sections describe concepts associated with license types, license violations, violation types, violation messages, and registration interaction with other QAD modules.

You can use User Monitor Inquiry (36.16.12) or other license-related reports to monitor user activities and application use.

Licensing updates and data, such as user counts and violations, are recorded in Universal Time, Coordinated (UTC). See “UTC and Transactions Outside Domains” on page 199.

## License Types

Two license types apply to users:

*Named User.* Each unique user ID defined in User Maintenance (36.3.1) is counted as a user. There is no limit on the number of sessions each defined user can run simultaneously. Multiple sessions for the same user ID are counted as one user.

*Concurrent Session.* Each concurrent login is counted as a session. If a single user logs into multiple sessions simultaneously, each login is counted. See “Violation Types” on page 182.

## User Counts

License usage is monitored regardless of your user interface type, database type (Progress or Oracle), or license type.

For concurrent session license types, the system counts the number of active sessions when you log in and compares the count to the number of licensed sessions stipulated by the license agreement.

If you change to a domain in another database, this process is repeated because changing databases is exiting the current database and starting a new session. Whenever you switch databases, the system stores the logout date and time. The time is recorded using UTC.

**Note** If you use the QAD .NET UI, each time you run a program and detach it in a separate window, each window counts as an individual session.

For named user license types, the software counts users when system administrators create new users in User Maintenance (36.3.1) or activate user access to applications in License Registration (36.16.10.1). See “Violation Messages” on page 182.

## License Violations

When the number of users or sessions exceeds the number stipulated by your license agreement, license violations occur.

The system stores all license violation occurrences in the database. System administrators and QAD auditors can run reports to view the violation data. See “License Reporting” on page 185.

The system responds to license violations with either violation errors or violation warnings. With errors, messages display and the system prevents additional users or sessions. With warnings, messages display, but additional users or sessions can exist and users can still log in to QAD applications.

System administrators can implement enforcement of license agreements by selecting the Enforce Licensed User Count field in Security Control (36.3.24). Setting this field determines whether errors or warnings display and what action the system takes. For more information on Security Control, see *QAD Security and Controls User Guide*.

**Important** The first time a warning displays, you can continue log in to complete transactions or other processing. If you receive repeated warnings, contact your QAD sales representative or distributor to upgrade your license.

The system prevents users from logging in if the license registration record does not exist for the foundation product in License Registration (36.16.10.1).

## Violation Types

The system records the violation types listed in Table 8.2.

**Table 8.2**  
License Violation Types

Violation Type	Description
Date Expiry	Displays information about violations that occur when an application's license registration expires. Only evaluation, demo, or temporary licenses have expiration dates.
Application Usage	Displays information about violations that occur when users do not have access to an application.
License Count	Displays information about violations that occur when the number of users or sessions exceeds the amount stipulated by the license agreement.
Non-Licensed Product	Displays information about violations that occur when users attempt to run applications that are not registered.

## Violation Messages

Table 8.3 lists error messages that display when license violations occur.

**Table 8.3**  
License Violation Error Messages

Message	Explanation and Solution
Expired license code	The license code expiration date for this application has passed.  Contact your QAD sales representative or distributor to obtain a new license code. Register new code in License Registration (36.16.10.1).
Product registration is not valid	The licence code data in your environment has been corrupted or is missing.  Contact your QAD sales representative or distributor to obtain the correct license code; register correct code in License Registration.
Application not available in licensed application master	Your environment license data has been corrupted or is missing.  Contact customer support to reload valid license data.

Message	Explanation and Solution
Licensed user limit exceed	This message displays in User Maintenance and License Registration when the number of users exceeds the number specified by the license.  System administrators can deactivate some users; otherwise, contact your QAD representative or distributor to upgrade your license agreement.
Customer is not licensed to execute this module/product: #	You selected a menu item that is not covered by registered license codes.  Contact your system administrator to determine the correct menu items for you to access.  System administrators should contact their QAD representative or distributor if the license code is not correct or if they wish to purchase this additional module.
User not authorized to run this application: #	You have not been authorized to run this product.  System administrators authorize users to use products in User Maintenance or License Registration.
This product expires in # days on #	The license code for this application expires in the number of days indicated.  Contact your QAD sales representative or distributor to obtain a new license code; register correct code in License Registration.
Concurrent session limit exceeded	The application you are attempting to access has a concurrent session license type and the maximum number of active sessions for this application has been reached.  If this error displays during login, you cannot log in unless another currently logged-in user logs out.

### Interaction with Other System Data

The license registration programs use data from other programs to process, maintain, and report license data.

System administrators maintain defined named users and a list of registered software applications that users are authorized to access in User Maintenance (36.3.1). License registration software uses this information to prevent more active users than the license allows.

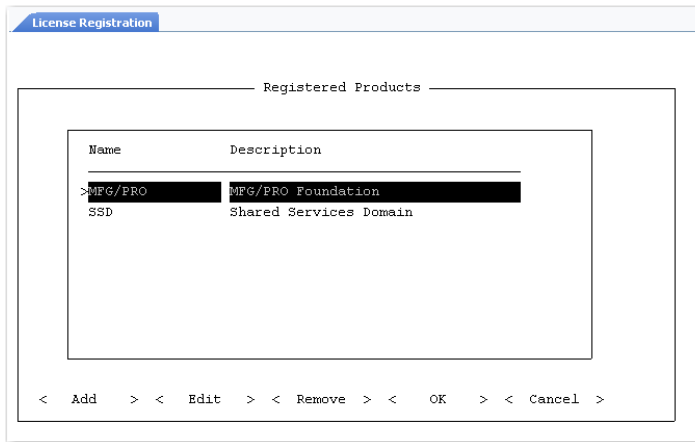
User Maintenance also includes information that more clearly defines the user. The system ships with a default set of user types predefined in Language Detail Maintenance (36.4.2). The set includes the employee, customer, and QAD user types. It is important for user count and system monitoring purposes that users are correctly identified in User Maintenance before complete license registration functionality can be used. See “Language Detail Maintenance” on page 47.

### License Registration

Use License Registration (36.16.10.1) to:

- Add a new license code for the foundation QAD software or separately licensed QAD modules.
- Upgrade license codes to add sessions or users.
- Remove license codes.

**Fig. 8.6**  
License Registration (36.16.10.1)



The system requests licensing information after you install your base QAD application or separately sold modules and when you attempt to log in with an expired license.

Use the Tab key to select a license code task:

*Add.* The Add Product frame displays. Enter the license code for the foundation product or a separately licensed module; then choose OK.

The application name, description, version, license type, and number of licensed users display.

When you add a license code, you are prompted to enter the IDs of users who can access the application. A list of users who can access the product displays once you enter a user ID. See “Granting Users Access to Registered Software” on page 184.

If you try to add an application that is already registered, the following message displays:

```
Product already installed
```

*Edit.* The Edit Product frame displays. Use this frame to upgrade your license to increase users or sessions. You must obtain the new number from your QAD representative or distributor.

After you enter the code and choose OK, you are prompted to enter the IDs of users who can access the application.

*Remove.* The Remove Product frame displays. Enter the license code for the application you want to remove from registration. A prompt displays, asking you to confirm the license removal. If you select Yes, the system records the removal date and time. The application is no longer registered, and users cannot execute any programs that are a part of it. If you remove the MFG/PRO license code, you will be logged out of the system, and users cannot log in.

### Granting Users Access to Registered Software

You must grant users access to registered software. If a user who does not have access tries to start an application, either an error or warning message displays depending on the value of Enforce Licensed User Count in Security Control (36.3.24).

Access to applications is granted in one of two ways:

- 1 Assign access to individual users by selecting registered applications in the Application List frame in User Maintenance (36.3.1). For more information on User Maintenance, see [QAD Security and Controls User Guide](#).
- 2 Activate users for a newly registered application in License Registration (36.16.10.1).

After you successfully enter a license code in the Add Product or Edit Product frames, the system displays the Add Authorized Users frame. You can specify a user ID to display a list of users starting with this ID or enter the word All. When you enter All, the list displays with all users selected, as indicated by an asterisk. You can deselect any that you do not want to include.

**Note** If the total number of users exceeds the number allowed by the application license, the system makes the first users in the list active. For example, if there are 100 user IDs displayed, but the license agreement for the application is for 50 users, the first 50 users are made active for the application.

If you need to authorize more users than your license allows, system administrators can add users through User Maintenance (36.3.1); however, the software records a violation of your license when you add more users.

## License Reporting

Various reports let you monitor application use, the number of logged-in users and sessions, the programs in use, and license violations. You can use the application usage and user count reports to be informed about potential license violations.

In addition to license reporting, you can use User Access by Application Inquiry (36.3.22) to display a list of applications, user access status (active or inactive), and access activation date.

### Licensed Application Report

Use Licensed Application Report (36.16.10.3) to display a list of software applications registered in the database.

You can select a range of applications to display. Selecting Show Only Active Licenses displays the current license code for an application. Clearing this field displays information on current and expired license codes for applications. Records display in descending order of the registration date. If there are multiple records for one application, the record with the latest registration date displays first.

The report includes the application description and version, license code and type, number of licensed users, registration and expiration date, user ID of the person who registered the application, audit date information, and any changes to license information.

Audit date information is recorded and displayed in Universal Time, Coordinated (UTC).

**Fig. 8.7**  
Licensed Application Report (36.16.10.3)

## Application Usage Profile Report

After you install and register an application, the software keeps statistics about your application use. The statistics include:

- Licensed application name
- Menu item executable program name
- Number of times the menu item is accessed
- Percentage of the application in use at the time of reporting

You can use Application Usage Profile Report (36.16.10.8) to display the recorded information for each licensed application.

**Fig. 8.8**  
Application Usage Profile Report (36.16.10.8)

You can generate the report in summary or detail format. Summary reports display only the module, access count, and percentage of application use. Detail reports display all recorded information about application usage.

## Detailed License Violation Report

Use Detailed License Violation Report (36.16.10.13) to display information about license violations, including:

- Violation date, time, and error message. The time and date are printed in UTC.
- User ID and name of the person who is in violation
- Violation type (for example, application usage or license count exceeded). See “Violation Types” on page 182.
- The total number of sessions and users logged in at the time of violation
- Session ID at the time of violation
- Percentage of the application in use at the time of violation

Detailed license violation reports let you select a range of registered applications, dates, user IDs, or violation types on which to report.

**Fig. 8.9**  
Detailed License Violation Report (36.16.10.13)

### Summary License Violation Report

Use Summary License Violation Report (36.16.10.14) to display:

- Application name, version, and license type
- Violation date
- Total number of violations
- Total number of violations by violation type
- Maximum number of licensed users logged on during a period or the *high water mark*
- Total number of licensed users

Summary license violation reports let you specify the application and the period you want the report to cover.

**Fig. 8.10**  
Summary License Violation Report (36.16.10.14)

If you do not specify an application, all violations for all applications display. If you specify an application, but no dates, all violations for that application display.

If you run either report and there are no violations to report, the following message displays:

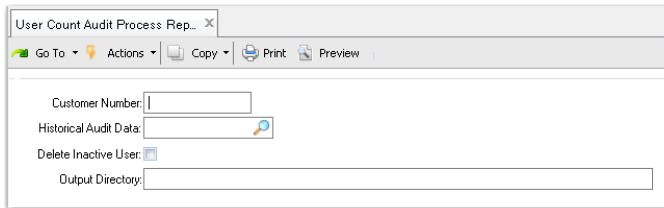
No violation observed.

### Audit Reporting

Use User Count Audit Process Report (36.16.10.16) to generate a set of files that can be used by QAD personnel when they perform a user count audit to evaluate compliance with license agreements.

Optionally, you can archive previously reported audit data to an external history file and delete it from your system, or delete without archiving. You can also have the program delete unneeded user records from the system while generating the audit records.

**Fig. 8.11**  
User Count Audit Process Report (36.16.10.16)



**Customer Number.** Enter the customer or end user number that QAD has assigned to your product installation.

The system uses this number as part of the identifier information in the generated files.

If you do not know your customer number, contact your QAD representative or QAD Support.

**Historical Audit Data.** Specify the way you want the system to manage historical audit data after generating the audit files:

**Archive:** The system creates an additional dated subdirectory (archive\_YYYY-MM-DD) under the specified Output Directory. That subdirectory includes an archive file using the naming convention <customer number>-UCA-<logical db name>-yyyymmdd-<time>.hst. The file contains audit data that is more than 400 days old.

After archiving the records, the system deletes them from the database. If required, you can restore records from an archive file to your system using Archive File Reload.

Note that the archive directory may include a second file. lvYYYYMMDD.hst contains the audit records that were used by the original audit module. User Count Audit Process Report has replaced that legacy functionality.

**Delete:** The system deletes audit data that is more than 400 days old from the database. Note that no archive file is created. If you want to maintain historical data outside your system, you should set this field to Archive.

**Retain:** The system does not delete or archive historical audit data.

**Delete Inactive Users.** Enter Yes to delete User Master records for any user IDs that have never been used to log in to the system.

You can use this option to clean up unneeded user IDs that may otherwise be included in license counts.

**Note** The system selects records based on the Active field in the Application List frame of User Maintenance. For each user where that field is No for application MFG/PRO and the user ID has never been used to log in, the system deletes the user record.

**Output Directory.** Enter the path to the directory where the system will create the files to be used for user count audits. If the directory does not exist, the system prompts you to attempt to create it from within the program.

When you execute the program, the system places the files in a subdirectory named in the format qad\_YYYY-MM-DD.

If you select Archive in the Historical Audit Data field, the system also creates the archive\_YYYY-MM-DD subdirectory.

## User Monitor Inquiry

User Monitor Inquiry (36.16.12) displays users currently logged in, along with the:

- License type and count for the application
- Program names and menu numbers they are currently executing
- Session ID and user interface type for the session
- Time since they started the current program or menu. The time is recorded and displayed in Universal Time, Coordinated (UTC).
- Amount of time they have been idle if no program is selected

This inquiry represents a single point in time, not a continuous system record or audit trail.

By monitoring user and program activity, the system administrator can identify users in violation of license agreements and minimize unnecessary overhead during peak system usage.

You can enter a combination of login time and users, applications, or menu selections to view details of a specific login scenario.

**Fig. 8.12**

User Monitor Inquiry (36.16.12)

**Application.** Enter the application name for which you want information to display. You can enter a range of applications by specifying the first application to display in this field and the last application to display in the To field.

**Menu Selection.** Enter the menu selection for which you want details to display. Leave blank to begin with the first menu matching the other selection criteria.

**Login Time.** Enter the login time for which you want details to display.

Enter the time based on a 24-hour clock in HH:MM format. For example, enter 1:30 pm as 13:30.

**User ID.** Enter the ID of the user for whom you want details to display. Leave blank to begin with the first user ID matching the other selection criteria.

**Sort Option.** Enter the number that corresponds to the way you want to arrange information in the User Monitor Inquiry. You can sort by:

- User ID, which sorts the data in alphabetical order by user ID.

- Idle Time, which sorts the data by the length of time a user has remained on a menu. The user with the longest idle time displays first.
- Program time, which sorts the data by the length of time a user has remained in a program. The user with the longest program time displays first.

## Managing Database Sequences

When a unique identifier is needed by a system function program, the system often uses a control field to store the last number used. The system also supports the use of a special schema element called a sequence.

A *sequence* is a database element used to generate a stream of sequential values for assigning unique identifiers to records. Sequences allow fast, accurate numbering, and reduce the amount of time the system spends validating uniqueness.

**Note** Because the sequence is generated at the database level, records viewed from within a domain may appear to have gaps.

Use Sequence Report (36.16.15) to display a list of sequences defined in the database. The sequence description indicates the database table and field that is updated by the sequence. For example, the description of sequence `cmt_sq01` is `cmt_det.cmt_indx`.

Sequences have the important advantage of speed and reducing the possibility of record locking and contention. However, each sequence is a separate database element, distinct from the table to which it applies. This means that sequences must be initialized correctly whenever you use Database Table Dump/Load.

If sequences are not initialized correctly, Duplicate Unique Key errors may occur when users attempt to create transactions.

If dumping and loading are done as part of installing a software upgrade, sequence initialization is automatically performed by the installation utilities. However, if you perform a dump/load to consolidate tables or increase database size, you must initialize sequences yourself. This is true also if you consolidate data from two different databases.

- Use Database Sequence Initialization (36.16.17) to reset sequences to the highest value plus 1 after loading data. This program works with both Progress and Oracle databases.
- Use Sequence Maintenance (36.16.13) to manually reset a sequence number to a specific value in a Progress database.
- Use Sequence Inquiry (36.16.14) or Sequence Report (36.16.15) to view sequence information.

To guarantee database integrity, perform sequence maintenance:

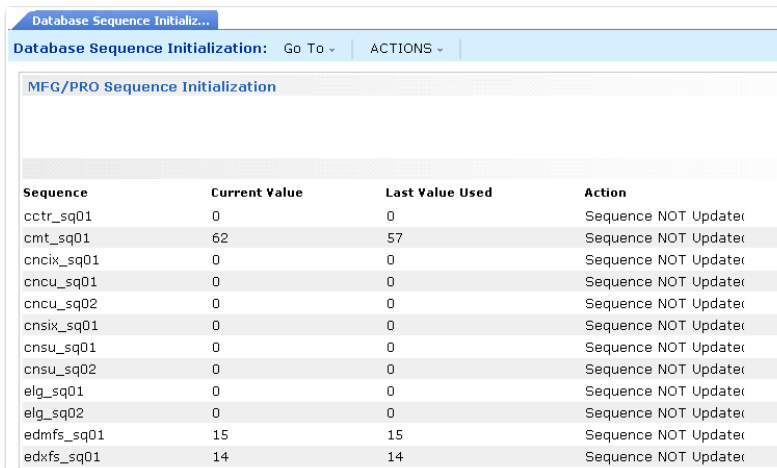
- In single-user mode sessions only
- As a required part of your standard database maintenance

**Note** To avoid accidental update to sequence structures, use menu security to protect sequence maintenance functions.

## Initializing Sequences

Database Sequence Initialization reads each table that uses sequences and sets the sequence number value to the highest number plus 1. This ensures that each new record created has a unique number. This utility initializes sequences correctly in both Progress and Oracle databases.

**Fig. 8.13**  
Database Sequence Initialization (36.16.17)



Sequence	Current Value	Last Value Used	Action
cctr_sq01	0	0	Sequence NOT Updated
cmt_sq01	62	57	Sequence NOT Updated
cncix_sq01	0	0	Sequence NOT Updated
cncu_sq01	0	0	Sequence NOT Updated
cncu_sq02	0	0	Sequence NOT Updated
cnsix_sq01	0	0	Sequence NOT Updated
cnsu_sq01	0	0	Sequence NOT Updated
cnsu_sq02	0	0	Sequence NOT Updated
elg_sq01	0	0	Sequence NOT Updated
elg_sq02	0	0	Sequence NOT Updated
edmfs_sq01	15	15	Sequence NOT Updated
edxf_ssq01	14	14	Sequence NOT Updated

## Maintaining Sequences Manually

Maintain sequences manually or through the CIM interface. Maintenance includes:

- Dumping—outputting the current sequence value to a file
- Loading—reading a sequence value from a file
- Updating—manually updating a single sequence

See “Maintaining Sequences in Oracle” on page 193.

Maintain sequences in Sequence Maintenance (36.16.13). Sequence Maintenance works with Progress Relational Database Management System (RDBMS) only. Oracle dataservers are not currently supported.

*Log File Name.* The name of the error log file.

*Directory.* The operating system (OS) directory where you want to store the file.

After you enter the log file name and directory and click Next, a second Sequence Maintenance frame displays. Enter data for the following fields in this frame:

*Sequence Name.* Specify the sequence or set of sequences to be maintained. Leave blank to specify all sequences.

**Note** A time stamp is added to the log at the beginning of each session, so session history can accumulate. After a maintenance session, check the log for errors.

*Maintenance Activity.* Specify the maintenance activity to be applied to the specified sequence sets. Valid values are:

- 1 to dump. Outputs the current sequence value to an OS file.
- 2 to load. Reads the sequence value from the OS file.

- 3 to manually update. This activity can only be performed when a single sequence is specified. When a set of sequences is to be manually updated, the manual update activity is called once for each.

*Activity Directory.* For a dump or load, specify the OS directory where the sequence files are located. The direction of the data flow is determined by the activity.

Files are named using the name of the sequence with the file extension `.d`. For example, the sequence `tr_sq01` is dumped to a file named `tr_sq01.d`.

When you specify manual update, the system displays the Manual Update frame. Specify the following in the frame:

*Original Sequence Value.* This field displays the value of the sequence before the user's update was applied.

*Current Sequence Value.* This field displays the current sequence value.

**Note** Sequence Maintenance generates a report listing current values of all sequences in the database. It can be run at any time and does not impact the content of sequence structures.

*User Input.* Enter any sequence value within the valid range. The valid range is determined by the system and is part of the schema. An error displays when the value entered is not within the valid range.

## Maintaining Sequences Using CIM

Sequences can be maintained using the CIM interface. The content of a sequence represents the last value applied to the sequence by a call from a system function. This value is not available for processing, since it was consumed by another process. See "Using the CIM Interface" on page 162.

Values used to update a sequence are validated against a range of acceptable values for the sequence, as established in the database schema. The value of the sequence can be within and including the boundary values. You receive an error message when the range is exceeded.

### Limitations of CIM

Some limitations to maintaining sequences through the CIM interface are:

- Sequence maintenance must be performed in a single-user mode Progress session. The integrity of the sequence value is not guaranteed if maintenance is done in multiple-user mode.
- Destructive updates are not permitted. A CIM update cannot overwrite previously created files. Data dumping does not proceed if any elements in the set of sequences conflict with an existing OS file.
- You cannot manually update from CIM. CIM is an automatic process.
- Any error causes the sequence maintenance to fail. When you suspect a sequence maintenance activity failed while processing, you must repeat the entire process. This guarantees that the sequence values are valid.

### Sample CIM File Format

A typical CIM file might look like the following illustration:

```

Line 1: <log file> <log directory>
Line 2: <sequence name>
Line 3: <action>
Line 4: <input-output OS directory>

```

**<log file>**. The name of the file receiving the output log. When an existing log file is specified, the current CIM output is appended to the end of the existing log. The default value is the value of the `mfguser` variable. This has the format of `TMP9999` where 9999 is a four-digit number that uniquely identifies the CIM session. If the `mfguser` value is `NULL ("")`, the log file is named `mgsqmt03`.

**<log directory>**. The location where the log file is stored. The blank value `NULL ("")` is specified as the default. When a `<log directory>` is not specified, the `<log file>` is placed in the `PROPATH`.

**<sequence name>**. Specifies the set of sequences to be maintained. You can specify a single sequence or the entire set. The default value is `NULL ("")`, indicating all sequences will be maintained.

**<action>**. Specifies the activity to be performed, either (1) dumping or (2) loading. The default activity is dumping (1).

**<input-output OS directory>**. The directory in which the sequence files are maintained. The default value is the local directory.

A time stamp is issued to the log file at the beginning of each session. This permits the same log file to accumulate a history of the session logs. All log files have the `.log` suffix.

**Example** The following is an example of a working CIM file:

```

@@batchload mgsqmt01.p
"sq_err.log" "/qad"
-
2
"/qad/backup"
@@end

```

This file outputs the error log to the directory `/qad` with the name `sq_err.log`. All sequences are maintained. The hyphen (-) indicates that the default value, in this case `all` sequences, is accepted. Number two (2) indicates that the sequences are loaded. The directory in which the sequence files are maintained is `/qad/backup`.

**Note** Only sequences currently implemented can be maintained using CIM.

## Maintaining Audit Trails

The system maintains audit trail for all updates made to sequences using sequence maintenance routines. Each sequence has a separate set of audit entries.

For each updated sequence, the audit trail records original and final values. If the current value is the same as the original value, the system creates only one record.

## Maintaining Sequences in Oracle

Normally, you use Database Sequence Initialization to set the starting sequence values in an Oracle database. The following information is provided if you need to manually maintain sequence values in Oracle, which cannot be done using Sequence Maintenance.

The standard sequence definition in Oracle is:

```
CREATE SEQUENCE <sequence name> START WITH <initial value>
INCREMENT BY 1 CACHE 75
```

Where *<sequence name>* is the same as defined in the Progress df and *<initial value>* is the starting value specified by the customer.

The initial value of a sequence is set to the highest value found in the field related to the sequence. The content of a sequence is the last value applied by a system function. See “Maintaining Sequences Manually” on page 191.

**Example** In a database with no user transaction processing, the maximum value of `tr_hist.tr_trnbr` is 1010. This value is used as the starting value of the sequence.

As user `qad`, you would enter the following SQL:

```
DROP SEQUENCE tr_sq01;
CREATE SEQUENCE tr_sq01 START WITH 1010 INCREMENT BY 1
CACHE 75;
```

## Component Record Numbering

The Record Numbering function lets you set a starting number for a specific business component, for example, numbers for printed checks. Numbers are always generated by financial year and by entity.

Usually, the number is reset to one at the beginning of a new fiscal year, but you can also set it to a certain value during the accounting year. To add a new number, right-click in the grid and choose Add New Row.

**Note** It is recommended that only experienced system administrators use this feature. Changes to the numbering system are logged for audit, and unauthorized changes could lead to issues of accounting legality where gaps in the numbering sequence result.

For external daybooks, sequence numbers are generated by the external transaction. However, the numbering function still generates a number series, which will be unused. The system also validates duplicates when numbers are passed from an external application. For transactions originating externally, the Record Number function is only used if a sequence number is not passed from the external system.

The Record Number function supports a single activity, Maintain, which lets you modify the numbering system. You cannot modify an existing number, but you can right-click and add a new row, to reset the sequence for a numbering type.

**Fig. 8.14**  
Record Number Maintain (36.16.21.2)

Status	Year	Type	Number
Claimed	2006	AR Finan	00000001
Claimed	2006	AR Finan	00000003
Claimed	2006	AR Finan	00000046
Claimed	2006	AR Finan	00000047
Claimed	2006	AR Finan	00000052
Claimed	2006	AR Finan	00000053
Released	2006	AR Finan	00000054
Released	2006	AR Finan	00000055
Released	2006	AR Finan	00000056
Released	2006	AR Finan	00000057
Released	2006	AR Finan	00000058
Released	2006	AR Finan	00000059
Released	2006	AR Finan	00000060
Released	2006	AR Finan	00000061
Released	2006	AR Finan	00000062
Free	2006	AR Finan	00000063
Released	2006	Bank	00000001
Released	2006	Bank	00000002
Released	2006	Bank	00000003
Released	2006	Bank	00000004

## Field Descriptions

**Status.** Displays the status of the number. When creating a number record, the field is automatically filled with the status Free.

The numbering statuses are as follows:

**Free:** The number is being used for the first time.

**Claimed:** The system selects the lowest available number in the series with the status Free or Released. If the transaction has not been saved, the system assigns the status Claimed to the number. When the transaction is saved, the system removes the number from the list of available numbers. If the transaction is not saved, the system assigns the status Released to the number.

Claimed numbers are currently being used by a running transaction.

**Example** Numbers 18 and 19 are claimed by running transactions. The transaction that claimed sequence number 18 is abandoned and 18 is released. Sequence number 18 then becomes the next available number, even though 19 is already used.

The Claimed status is also required because, in a client-server environment, if the connection is lost, the number will remain claimed on the client side. This is repaired the next time the server is started and system housekeeping takes place.

**Released:** The number was used previously for a transaction that was not saved. The system releases the number again for use for the next transaction.

**Draft:** The number is used in a draft object. If the object is deleted, the system sets the number status to Released. The system removes the number from the list of available numbers when the user saves the draft object.

**Year.** Specify the accounting year for which you want to create a numbering sequence. The combination of the number year and type must be unique within the entity.

**Type.** Specify the accounting daybook or number series for which to create the number series. The combination of the number year and type must be unique within the entity.

*Number.* Specify the first number in the numbering sequence. If you do not specify an initial value, the system starts with 1. Each value in the sequence is incremented by one.

## Setting Up Multiple Time Zones

Accommodating variations in local time is a special global business challenge. The Multiple Time Zones Setup menu (36.16.22) lets you create and maintain time zone data.

- Use Multiple Time Zones Maintenance (36.16.22.1) to define and maintain multiple time zones, including the changes required by daylight savings time.
- Use Multiple Time Zones Inquiry (36.16.22.2) and Multiple Time Zones Report (36.16.22.3) to display and report time zone information.
- Use Multiple Time Zones Load Utility (36.16.22.13) to load sample time zone data.
- Use Domain Create (36.1.1.1.1) or Domain Modify (36.1.1.1.2) to specify the time zone that applies to a particular domain.

You should restrict access to these programs, with the possible exception of the report and inquiry. Do not change time zone information without carefully evaluating the impact.

### Multiple Time Zones Maintenance

Use Multiple Time Zones Maintenance (36.16.22.1) to define and modify time zones.

**Note** The Multiple Time Zones Load Utility lets you load your own time zone data.

This program supports two ways of setting up a time zone:

- In the simplest format, you can base a time zone on an offset from GMT.
- The system can also track daylight savings time adjustments from a baseline you set.

If you choose the second approach, you must specify when the change in time occurs. You can also use effective dates with time zone information, if the start and end points for daylight savings time only apply for a range of years.

After you define the time zones, you can generate reports with Multiple Time Zones Report (36.16.22.3). Figure 8.15 illustrates Multiple Time Zones Maintenance.

**Fig. 8.15**  
Multiple Time Zones Maintenance (36.16.22.1)

Start Year	End Year	GMT Offset	Month	Weekday	Week	Day	Time
2010	2010	01:00	03	0	<input type="checkbox"/>	28	02:00

*Time Zone.* Enter an eight-character label identifying a time zone.

*Description.* Enter up to 40 characters describing this time zone. The description appears in the time zone lookup.

*Auto Period Adjust.* This field indicates whether the system should adjust the time zone you are defining for a given period—usually daylight savings time or its equivalent.

Selected: Define the period to be adjusted in the subsequent detail frame.

Clear: Time Period defaults to STD (standard). You cannot change it.

*Time Period.* This field is editable if Auto Period Adjust is selected. Valid choices are STD for standard time, Day for daylight-saving time, and Sum for summer time. You can define details for two periods: a standard period, and a special adjusted period for daylight savings or its equivalent. This field determines which of the detail fields are required.

**Note** Set up values for time period as language details to reflect the terms you use.

*Start Year.* Enter the beginning year of the range associated with this time zone definition. In some countries, the implementation of time zones varies from year to year. Using start and end dates, you can set up multiple records effective at different periods of time.

*End Year.* Enter the ending year of the range associated with this time zone definition. If you do not know when the current definition ceases to be effective, use an end year such as 9999.

*GMT Offset.* Enter the actual offset in hours and minutes from Greenwich mean time (GMT) for this time zone. Enter this number with either a plus sign (+) or minus sign (–) indicating the direction of the offset.

GMT is the base for establishing the relationships among time zones and is never affected by daylight-saving time adjustments.

*Month.* Specify the month in which daylight savings starts or ends. The month is expressed as a numerical value between 1 and 12. For January, enter 1; for February, enter 2, and so on.

This field is mandatory.

*Weekday.* When Auto Period Adjust is selected, enter a number from 0 to 7 indicating the day of the week when the time change occurs. In the U.S., time changes always occur on Sunday (1).

- Enter 0 if the change occurs on the date in the Start Date field, regardless of the day of the week on which it falls.
- Enter a number in the range 1-7 corresponding to Sunday through Saturday if the change occurs on a certain day of the week.

*Week.* Specify the week in the month in which daylight savings starts or ends. The week is expressed numerically and must be a value between 1 and 5, where 5 indicates the last week in the month. You can only use this field if you also specify a value in the Weekday field.

**Note** The Week field only takes effect if the Weekday field contains a non-zero value.

You can use this field and the Month and Weekday fields to define cases where daylight savings time begins on a particular weekday in a month, rather than on a set date every year. For example, in the US, daylight savings time begins on the second Sunday of March and ends on the first Sunday of November.

**Day.** Specify the particular day in a month on which daylight savings starts or ends. The day is expressed numerically and must be a value between 1 and 31. You can only specify a value in this field if the Weekday field is set to 0.

You can use this field and the Month field to define situations where daylight savings time begins on a particular date in the year. For example, in Honduras, daylight savings time began on 7 May, 2010.

**Time.** When Auto Period Adjust is selected, enter the exact time of day, using a 24-hour clock, when the time change occurs. Enter this time in standard time.

In the United States, enter 02:00 when switching from standard time to daylight-saving time, but 01:00 when switching from daylight savings time back to standard.

## Multiple Time Zone Load Utility

Use the Multiple Time Zone Load Utility (36.16.22.13) to load your own set of time zone data.

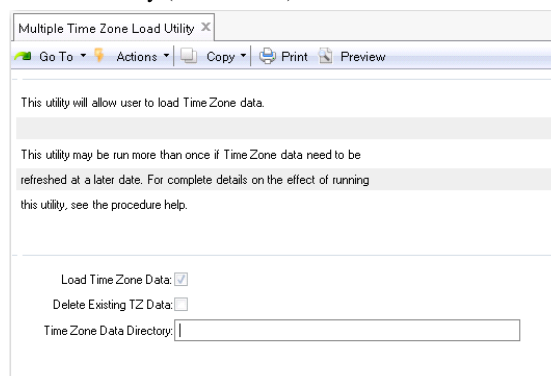
QAD's default time zone data is loaded automatically during the installation process. You need only use the Multiple Time Zone Load Utility if you want to load your own time zone data. QAD's default time zone data is located in the \$QAD\_EE\_INST\_DIR/db/mfg directory.

After you load your time zone data, verify that the time zones are valid and appropriate for your business practices. Use Multiple Time Zones Report (36.16.22.2) or Inquiry (36.16.22.3) to review definitions and ensure they conform to your requirements. Each organization is responsible for maintaining and updating time zone data to correspond to changing realities and business requirements.

If needed, you can delete existing time zone data and reload your time zone data.

Figure 8.16 illustrates the Multiple Time Zone Load Utility.

**Fig. 8.16**  
Multiple Time Zone Load Utility (36.16.22.13)



**Load Time Zone Data.** Select this field to indicate that you want the system to load your own time zone data.

After loading, verify that the time zones are valid and appropriate for your business. Use Multiple Time Zone Report or Inquiry to ensure the definitions conform to your requirements.

**Delete Existing TZ Data.** The system considers this field only when Load Time Zone Data is selected. If you are loading time zone data, you can also delete current time zone definitions. Use this feature if you want to reinitialize the sample data.

*Time Zone Data Directory.* Specify the directory from which to load the time zone data.

If you select the Load Time Zone Data field, this field is mandatory and cannot be blank.

## Setting a Default Time Zone

The Use User's Time Zone for Default Domain field in Database Control (36.24.1) affects the time stamping of transactions you create in your default domain. See "Database Control" on page 144.

**Important** If you are using the optional Service/Support Management module and the Multiple Time Zone option is activated in Service Management Control (11.24) for any domain in the database, you should not activate the Use User's Time Zone for Default Domain field.

## Domain Time Zone

Each domain can be associated with a time zone, and all transactions in the domain are assigned system dates and times based on that time zone. Use the Time Zone field in the Domain record to specify the time zone that applies to a particular domain.

When using your QAD application, if you change to another domain with a different time zone, that time zone now applies and any transactions you create in that domain are assigned dates and times relative to the time zone you have switched to. When calculating the time zone offset, the system also determines whether daylight savings time is in effect for that time zone, and adjusts accordingly.

If the Use User's Time Zone for Default Domain field is activated in Database Control (36.24.1), your default time zone from User Maintenance (36.3.1) is used when you switch to your default domain. The Use User's Time Zone for Default Domain field is deactivated by default. See "Setting a Default Time Zone" on page 199.

## UTC and Transactions Outside Domains

Any transactions you perform before you log into a domain are recorded in Universal Time, Coordinated (UTC).

UTC was formerly known as Greenwich Mean Time (GMT), and uses a 24-hour system of time notation, where "1:00 am" in UTC is expressed as 0100. The use of UTC time ensures that administrators can easily compare times and dates across multiple time zones.

Any transactions that are not tied to a particular domain are also recorded in UTC; for example, session master, user monitor, user logon date, license violation, and product registration record updates.

The following table lists the database tables and programs that timestamp updates in UTC:

**Table 8.4**  
Functions that Use UTC

Table	Date Field	Time Field	Programs
sess_mstr	sess_date	sess_time	<ul style="list-style-type: none"> <li>• Web program that sets/resets context when launching (mfwb02.p)</li> <li>• Session Context Manager (mfsessmg.p)</li> <li>• Appserver Session Manager Program (mfsemstr.p)</li> <li>• Login program to check the user ID and starting session context (mflg01.p)</li> </ul>
usr_mstr	usr_last_date	usr_last_time	<ul style="list-style-type: none"> <li>• User Inquiry (mguriq.p)</li> <li>• Force Password Change Utility (utfrcpsw.p)</li> <li>• User password library (mgurlib.p)</li> <li>• User Maintenance (mgurmt.p)</li> <li>• User Password Maintenance (mgurmtp.p)</li> <li>• Session Initialization Procedure Library (mfinitpl.p)</li> </ul>
	usr_logon_date	usr_logon_time	
mon_mstr	mon_login_date	mon_login_time	<ul style="list-style-type: none"> <li>• Displayed Sorted License Monitor Output (lvmoninq.i)</li> <li>• User Count and Licensing (lvgenpl.p)</li> <li>• User Monitor Inquiry (lvmon.p)</li> </ul>
	mon_date_start	mon_time_start	
		mon_idle_time	
cnt_mstr	cnt_date	cnt_time	<ul style="list-style-type: none"> <li>• User Count and Licensing (lvgenpl.p)</li> <li>• User Count (lvcount.p)</li> <li>• Lock Session and Monitor Records (lvlock.p)</li> </ul>
lvr_det	lvr_date	lvr_time	<ul style="list-style-type: none"> <li>• Summary License Violation Report (lvlsrp.p)</li> <li>• Detailed License Violation Report (lvldrp.p)</li> <li>• User Count and Licensing (lvgenpl.p)</li> </ul>
pin_mstr	pin_inst_date	pin_inst_time	<ul style="list-style-type: none"> <li>• Dialog for Entering PIN Numbers (lvpin.p)</li> <li>• License Registration (lvreg.p)</li> <li>• Licensed Application Report (lvlarppa.p)</li> </ul>
	pin_aud_date		
	pin_aud_ddate		
	pin_mod_date		
pex_mstr	pex_inst_date	pex_inst_time	<ul style="list-style-type: none"> <li>• Dialog for Entering PIN Numbers (lvpin.p)</li> <li>• License Registration (lvreg.p)</li> <li>• Licensed Application Report (lvlarppa.p)</li> </ul>
	pex_aud_date		
	pex_aud_ddate		
	pex_mod_date		

Table	Date Field	Time Field	Programs
hwm_det	hwm_date	hwm_time	<ul style="list-style-type: none"> <li>• Summary License Violation Report (lvlsrp.p)</li> <li>• User Count and Licensing (lvgenpl.p)</li> </ul>
uslh_hist	uslh_hist	uslh_time	<ul style="list-style-type: none"> <li>• Session Initialization Procedure Library (mfinitpl.p)</li> <li>• Appserver for the API Procedure Library (mfaspl.p)</li> <li>• Logon Attempt Report (mgurpsrp.p)</li> </ul>
lua_det	lua_in_date	lua_in_time	<ul style="list-style-type: none"> <li>• User Count and Licensing (lvgenpl.p)</li> <li>• License Violation Delete/Archive (lvldup.p)</li> </ul>
	lua_out_date	lua_out_time	
usg_det	usg_date		



# Reports and Utilities

This chapter includes information on master table audit reports, system cross-references, which let you identify how and where fields and tables are used, application server definitions, operating system commands, and delete/archive utilities. The Statutory-Currency Utility is also described.

***Generating Auditing Reports 204***

Discusses auditing and other reports.

***Using System Cross-References 204***

Explains how to use the System Cross-Reference menu, with background information and information on table, field, and menu reports, using program reports, and updating cross-references.

***Setting Up Application Servers 208***

Discusses the process AppServer, including how to define one, and gives an example of using the AppServer to run MRP.

***Using Operating System Commands 211***

Describes different operating system commands and how to use them.

***Using Delete/Archive Utilities 212***

Explains how to use Audit Detail Delete/Archive and GL Transaction Delete/Archive.

***Statutory-Currency Utility 212***

Describes how you can use a utility to change the statutory currency of a domain, even after transactions have been posted.

***Command Line Application Control 214***

Explains how to use the application control program.

## Generating Auditing Reports

You can review modifications to tracked master tables using Master Data Audit Report (36.17.1), which prints changed records in master tables. The report includes the database table name, current version of the changed record, user ID of the person who made the change, and date.

The system offers other auditing functions:

- Auditing information for unposted general ledger (GL) transactions is maintained when GL Transaction Audit Trail is selected in GL Operational Transaction Control (36.9.13). When selected, any changes made in Unposted GL Trans Correction (25.13.16) are logged.
- GL Trans Correction Audit Report (25.13.17) shows changes made to unposted GL transactions (accounts, sub-accounts, cost centers, and projects) using Unposted GL Trans Correction
- Use Change Tracking Maintenance (36.2.22) to track changes to sales order detail fields. See “Tracking Changes” on page 34.

### Other Reports

Use Master Comments Report (36.17.5) to print the text of master comments selected by a range of references and by type and language.

Use Control Tables Report (36.17.6) to generate a report listing the current values defined for all control tables in the system. This report is especially important during implementation. It enables you to verify that settings are appropriate for your business environment.

## Using System Cross-References

The System Cross-Reference menu (36.18) contains programs that identify how and where fields and tables are used within standard Progress programs.

**Note** These functions do not report any information about component-based functions.

System cross-reference activities can be customized to reflect your system setup. This lets you update cross-references when you add or change menu items. If you do not customize the system, you can use the cross-reference as it is.

The cross-reference database requires about 50 MB of disk space, and consists of a set of reports summarizing database relationships such as:

- Which X and Y are used by this Z? X, Y, and Z can be tables, fields, menu items, or programs. *Used* can mean referenced, updated, or called.
- Which database tables are referenced or updated by this menu item?
- Which menu items call this field?
- Which program source files use this include file?

You construct a cross-reference in two steps:

- 1 Compile the entire system.
- 2 Build a bill of material from the menu structure.

The end result is a bill of material for each program, in which all programs called by the initial program are components, as well as fields called or updated by those programs.

Cross-reference reports provide different ways of organizing the bill of material.

## Background

The core modules of QAD Enterprise Applications consists of approximately 6200 programs that call some 10,000 fields. The programs consist of normal, executable Progress programs (.p files) and include files (.i files), which can be called from many different .p files.

The menu system calls approximately 1400 of those 6200 programs. These called programs call numerous other .p and .i files. Progress programs can be nested, enabling you to place .i files within .i files, and so on.

These Progress programs read or change information in database tables, such as the item master (pt\_mstr) or the printer master (pr\_mstr). The database tables consist of records containing entries in a group of fields.

When Progress is compiled, the list of programs called and the tables and fields read or potentially updated by those programs can be output. This output, along with other utility information, is the source of the cross-reference.

## Table, Field, and Menu Reports

The eight cross-reference reports answer such questions as “What does this table, field, message, menu item, or program do?” The syntax is XYZ. For example, the Tables/Fields by Menu Report tells you what tables X and/or fields Y are called by or updated by menu item Z. Similarly, Menu Item by Message Report tells you which menu items X/Y call a particular message Z.

**Table 9.1**  
Table, Field, and Menu Reports

Program Name	Description
Tables/Fields by Menu Report (36.18.1)	Shows what tables or fields are referenced or updated by programs called by a top-level menu. Limit searches further by execution file, database table, and field. Report includes the type of actions performed by the selected programs on each table or field listed. Action types are create, search, update, delete, and access.
Tables/Fields by Program Report (36.18.2)	Similar to 36.18.1, but not limited to menu-level programs. Shows what tables or fields are referenced or updated by the named Progress program.  Before running this report for a top-level program, first use Program Source File Report (36.18.16) to generate a list of subprograms called by the program. Then, run Tables/Fields by Program Report for each relevant subprogram.
Menu Items by Field Report (36.18.4)	Shows which menu items call a field or range of fields. Further limit searches by execution file and database table. Shows field name and table, calling menu item, and kind of action performed. Action types are create, search, update, delete, and access.

Program Name	Description
Menu Items by Table Report (36.18.5)	Similar to 36.18.4, but limited to a database table or range of tables, rather than fields. Shows which menu items call a table or range of tables. Further limit searches by execution file and menu item. Shows table name, menu item, execution file, and kind of action performed. Action types are create, search, update, delete, and access.
Menu Items by Message Report (36.18.6)	Shows which menu items call a particular message or range of messages. Further limit searches by menu and execution file. Shows message numbers and message text.
Messages by Menu Item Report (36.18.8)	Shows all the messages called by a particular menu item. Further limit searches by menu and execution file. Shows message numbers and message text.

For all reports, the top-level selection is the first one searched. To speed up processing, enter values in the top level.

## Using Program Reports

Program reports list all programs— .i files and .p files—called by a menu item.

**Table 9.2**  
Program Reports

Program Name	Description
Programs by Field Report (36.18.13)	Shows all programs that call a particular field or range of fields. Further limit searches by table name and program name. The report includes the following: <ul style="list-style-type: none"> <li>• The name of the database table to which each selected field belongs.</li> <li>• The names of the programs and subprograms that reference each selected field.</li> <li>• The types of actions performed on selected fields by each program or subprogram listed. Action types are create, search, update, delete, and access.</li> </ul> <p>This program may be useful when a field characteristic has been changed and the programmer wants to know what programs are affected.</p> <p>When you generate a report on programs that reference a specific field such as pt_part, programs using phrases like where so_part=pt_part are not included in the report.</p>
Programs by Table Report (36.18.14)	Similar to 36.18.13. Shows all programs that call a particular database table or range of tables. Further limit searches by program name. Useful when a table has changed.
Program Source File Report (36.18.16)	Creates a list of program components, or bill of material, for a specified program or range of programs. Shows all component parts, including nested executable files and include (.i) files, that are directly called by the specified programs.

Program Name	Description
Program Run Report (36.18.17)	Creates a multilevel list of components, or bill of material, for a specified program or range of programs. Shows all component parts, including nested executable files and include (.i) files, that are either: <ul style="list-style-type: none"> <li>• Directly called by the specified parent program</li> <li>• Indirectly called by subprograms or include files that are, in turn, called by the specified parent program</li> </ul> Use the Levels field to specify the number of levels to include in the report. For example, set Levels to 1 to list only the subprograms and include files directly called from the parent program.
Source File Where-Used Summary (36.18.19)	Shows which executable files use a specified source (.p) or include (.i) file or range of files. Useful if you change an include file and want to see the executable files affected. <p>This program does not list intermediate include files. Use Source File Where-Used Detail (36.18.20) to generate a report on intermediate include files as well as top-level program files.</p>
Source File Where-Used Detail (36.18.20)	Similar to 36.18.19. Shows which executable files use a specified source or include file; also shows intermediate include files. <p>Use the Levels field to specify the number of levels to include in the report. For example, set Levels to 1 to list only the executable files that directly call the specified source or include files.</p>
Run Program Where-Used Detail (36.18.21)	Shows which source (.p) and include files (.i) reference a specified subprogram. Lists both top-level source files and intermediate include files. Useful if a called program has changed, and you want to check the behavior of the calling programs. <p>Use the Levels field to specify the number of levels to include in the report. For example, set Levels to 1 to list only the files that directly call the specified subprograms.</p>
Program Summary Bill File Create (36.18.23)	Creates a list of components, or bill of material, for a specified program or subprogram, showing all files in the order in which they are called. List includes all subprograms called by the specified parent program, as well as fields updated by those subprograms. Can include multiple calls of the same file. Report output is placed in an ASCII file, where you can manage it using operating system tools. <p>For example, if you change the name of a called program, use Program Summary Bill File Create to make sure you change each instance of it in the source code.</p>

## Updating the Cross-Reference

The cross-reference is built by compiling programs, then checking the compiled programs against the menu. If you change menus or change programs, rebuild the cross-reference using Cross-Reference Update Menu (36.18.24).

Rebuild cross-references as follows:

- 1 If the source has changed, run Cross-Reference Update from Source (36.18.24.1).
- 2 Run Missing Component Program (36.18.24.15), Missing Menu Execution File (36.18.24.16), and Programs with No Menu Exec (36.18.24.18) reports.  
These reports show any errors in menu or program listings. Missing Menu Execution File Report, for instance, shows names of programs called by the menu that do not exist.
- 3 After making corrections, add parent-component relationships not included in step 1. Missing parent-components are supplied by the cross-reference.
- 4 Run Menu Item Cross-Reference Create (36.18.24.3) to link all cross-reference items with the menu.
- 5 Delete obsolete cross-reference items.

## Setting Up Application Servers

### Progress Application Server

The Progress Open Application Server, or AppServer, is a brokered collection of 4GL engines that can execute Progress programs on the server in response to remote client requests. Each AppServer instance is identified by a unique name, and contains a broker that manages a pool of 4GL engine processes, each of which is available for processing client requests. See the Progress documentation for more information on setting up and using AppServers.

The client connects to an AppServer indirectly through the Progress Name Server. This provides for location transparency (and also provides the logical basis for load balancing and failover) since the clients do not need to know the host and port of the AppServer broker. The client only needs to know the unique name of the AppServer broker, which is used by the Name Server to determine the broker's host and port.

Each AppServer instance can be configured to have its own set of parameter values such as the PROPATH, database connections, startup/shutdown procedures, and log files. These parameter values are specified in the `configuration.properties` file, located in the `build/config` directory, where `build` is the installation directory.

One extremely useful example of the AppServer is to improve the throughput speed of the processing-intensive task of running material requirements planning (MRP). The AppServer can distribute processing load across multiple threads, dramatically improving performance. For more information on MRP, see *QAD Manufacturing User Guide*.

As an example of how an AppServer can be used, this chapter includes instructions for setting up an AppServer to support enhanced MRP performance. See “Using an Application Server to Run MRP (Example)” on page 209.

Before you can run applications using a Progress AppServer, the AppServer instance must be defined in AppServer Service Maintenance (36.19.1).

## Using an Application Server to Run MRP (Example)

This section shows a practical example of how to set up an application server to dramatically improve the performance of MRP.

To use the MRP application server, you need to perform four main tasks:

- Modify the `configuration.properties` file.
- Configure the application server.  
See “Configuring the AppServer” on page 209.
- Defining the application server.  
See “Defining the AppServer” on page 210.
- Start and stop the application server as required.  
See “Starting and Stopping the Application Server” on page 211.

For more information on MRP, see *QAD Manufacturing User Guide*.

### Configuring the AppServer

Improved MRP performance requires a single AppServer with multiple threads, which is used to execute the programs that process planning data when you run MRP. Use the following instructions to configure that AppServer.

#### All QAD Installations

Use this procedure to configure an AppServer instance for all QAD installations.

In the example shown below, the name for the AppServer instance is `as-mrp`. However, you can use any name, as long as all references to the name are consistent. Add an entry for the required AppServer instance to the `configuration.properties` file in the `build/config` directory.

You can copy the following text into the file. Be sure to change the parameters to match your environment. Parameter changes are described after the sample text.

#### Progress Example

```
# @extends appserver.mfg
appserver.mrp=
appserver.mrp.name=as-mrp
appserver.mrp.operatingmode=State-reset
appserver.mrp.initialsrvrinstance=12
appserver.mrp.maxsrvrinstance=20
appserver.mrp.minsrvrinstance=12
portNumber=<port number>
appserver.mrp.manual=true
```

The parameters of interest are described below. Parameters not listed should generally not be changed from the values given in the example.

**Important** The first line of the entry specifies the name of the AppServer instance. If this is changed from the name in the example, be sure to change all other occurrences of this name in the other parameters.

portNumber is the port number for the AppServer broker for this instance. The value you specify should be a TCP/IP port number.

Since the AppServer broker `as-mrp` is used internally by the QAD software, you must use AppServer Service Maintenance (36.19.1) to define an application server connection master record. See “Defining the AppServer”.

### Defining the AppServer

Use AppServer Service Maintenance (36.19.1) to define the information needed to connect to a Progress AppServer.

You can specify a set of standard connection parameters used to connect to this server. Optionally, you can also define server-specific parameters required by the AppServer.

**Note** The example shown in Figure 9.1 includes the data you would enter to define an AppServer used to improve MRP performance. See page 209.

**Fig. 9.1**  
AppServer Service Maintenance (36.19.1)

The screenshot shows the 'AppServer Service Maintenance' window. The 'Service Name' field contains 'Multithread'. The 'Description' field contains 'AppServer for MRP'. The 'Application Service' field contains 'as-mrp'. The 'IP Address or Host Name' field contains 'localhost'. The 'Port Number' field contains '23601'. Below these fields is a 'Parameters' section with an empty text box.

**Service Name.** Enter a name to identify this application server.

**Description.** Optionally, enter a description of the application server.

**Application Service.** Enter the name of the application server defined in the `configuration.properties` file.

**IP Address or Host Name.** Enter the IP address or host name used as the `-H` parameter when connecting to this application server. This is the IP address or host name of the machine on which the application server is running. If the application server is running on the same machine as your QAD database, enter `localhost`.

**Port Number.** Enter the name server port number.

Use the following command to retrieve the port number of the name server:

```
yab config ns.portnumber
ns.portnumber=23601
```

*Parameters.* Optionally, enter any other parameters required when connecting to this application server.

## Starting and Stopping the Application Server

QAD Enterprise Edition is installed using the QAD Enterprise Edition installer and is managed using the Enterprise Edition Administration Console, also known as YAB. YAB is a deployment and management tool set that covers all products installed into an Enterprise Edition environment.

The application server instance configured in the example on page 209 can be administered using the `yab` command. You must have Progress administrative privileges to execute `yab` commands.

**Important** Make sure that all databases to be connected to the application server are running before you start the application server.

The command usage is as follows:

- To apply or reapply the application server configuration to the system:

```
> yab reconfigure
```

After applying the configuration to the system, you can start and stop the application server, as needed.

- To start the MRP application server:

```
> yab appserver-mrp-start
```

- To stop the MRP application server:

```
> yab appserver-mrp-stop
```

- To see the application server status:

```
> yab appserver-mrp-status
```

- To have the application server start and stop with the rest of the components in the environment, adjust the following setting:

```
appserver.mrp.manual=false
```

- To display help for all application server settings:

```
> yab help appserver
```

## Using Operating System Commands

The Operating System Commands menu provides four ways to access the operating system and execute commands directly from your QAD application. Use them as a convenient way of viewing and manipulating information.

- Use Exit to Operating System (36.22.1) to invoke a UNIX or Windows command session. To return to your QAD application, enter Exit.
- Use Program/Text File Display (36.22.4) to display the content of an ASCII file, such as a program or print file. If the file is not in the current directory, specify the path. Add this function to the User Menu so that users can generate reports to a file and quickly review the content.

- Use Disk Space Inquiry (36.22.13) to execute an operating system command to display statistics regarding the current database file size.

## Using Delete/Archive Utilities

### Audit Detail Delete/Archive

To delete data from an audit log, use Audit Detail Delete/Archive (36.23.1). This program works differently from other system delete/archive functions. It does not delete each record specified. Instead, for each unique combination of user ID, table, and field, it keeps the latest record and deletes/archives the rest.

Use this function to produce a report of records before deleting them. See “GL Audit Detail Delete/Archive” on page 175 for an exact procedure.

**Important** See “Deleting and Archiving Data” on page 174 for detailed information on the other delete and archive functions.

### Statutory-Currency Utility

Use the Statutory-Currency Utility (36.25.90) to change the statutory currency code of a domain to a different currency, even after transactions have been posted in the domain. The utility reinitializes the statutory currency amount fields for all transactions in the domain.

The utility uses Statutory exchange rates, if available, to convert all transactions in the domain to statutory currency. To perform this process, ensure that exchange rates exist from all the transaction currencies to the statutory currency for all dates for which there are transactions in the domain. This process is resource intensive so the timing must be carefully planned. The new statutory currency values are equivalent to the transaction currency amounts converted using the Statutory exchange rate valid on the posting date of the transaction. If the system cannot find a statutory exchange rate that is valid for that date, it reverts to using the Accounting exchange rate, if the Fallback to Accounting field in Exchange Rate Type Create (26.3.1) is selected for the statutory exchange rate. For more information on currencies and exchange rates, see [QAD Financials User Guide](#).

Before you run the Statutory-Currency Utility, stop the History daemon and the Balance daemon. It is also recommended that you increase the time-out parameter in the `homeserver.config` file, so that the UI does not time out and disconnect during the session. This recommendation displays on screen when you start the statutory currency conversion. See Figure 9.3 on page 214.

### Choosing the Best Time to Run the Utility

In principle, you can run the Statutory-Currency Utility at any time. However, if you run the utility in the middle of the financial year, there will be some unresolved issues:

- The exchange gains and losses on historical transactions are not recalculated in the utility, and are translated from the base currency to the statutory currency. This translation occurs because, for exchange gains and losses, the transaction currency is the base currency. This situation means that the realized statutory currency exchange gains and losses that result from the conversion utility are not the real gains and losses.

- Historical year closing postings are translated from the transaction currency closing and reopening balances to the statutory currency. If the Statutory exchange rates in the system for the year closing posting date are not consistent, the closing and opening postings can become unbalanced. Therefore, make a one-time manual journal entry adjustment in statutory currency after you run the utility to obtain the desired statutory currency opening balances.

For the reasons listed in the previous two points, it is recommended that you implement statutory currency at the beginning of a new accounting year.

## Running the Utility

Use the Statutory-Currency Utility to update statutory currency values for a domain.

**Fig. 9.2**  
Statutory-Currency Utility

**Domain.** Specify the domain for which you want to run the statutory currency conversion.

You can only run the Statutory-Currency Utility for a single domain at a time.

**Base Currency.** This field displays the base currency of the domain and is read only.

**Statutory Currency.** Specify the new statutory currency value that you want to convert to. The default value for this field is the current statutory currency for the domain.

**Is Statutory.** Manually update the field to reflect the situation that will exist after the statutory currency conversion is run.

Select this field if the base currency will not be the same as the statutory currency after conversion.

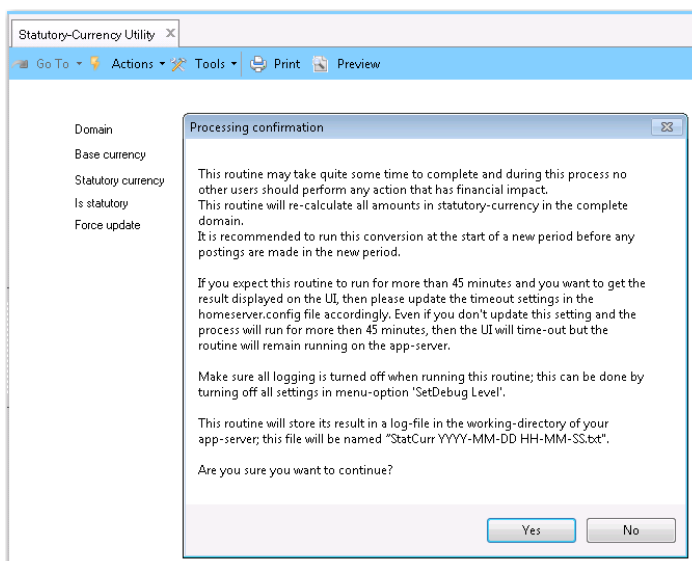
Clear this field if the base currency will be the same as the statutory currency after conversion.

**Note** The statutory currency becomes active if it is different than the base currency. Therefore, this field acts as an additional validation to remind you that you are activating or deactivating a second domain-level currency.

**Force Update.** Select this field if you do not want to change the current statutory currency, but you want the system to recalculate the statutory currency amounts.

When you click Execute to run the statutory currency conversion, the system displays a Processing Confirmation window. Click Yes if you are sure that you want to proceed with the conversion. To cancel the conversion, click No.

**Fig. 9.3**  
Statutory-Currency Utility, Processing Confirmation



**Important** When you are finished running the Statutory-Currency Utility, log off QAD Enterprise Applications and log back on to the updated domain before you can see the changed currency setting. This step is required because some domain-level parameters are cached in the session memory.

When the Statutory-Currency Utility is finished, you can restart the History daemon and the Balance daemon, but the daemons will take time to rebuild the balance totals, including the new statutory currency balances. Reports that use the summarized transaction history table (PostingHist) to display GL account balances are only accurate when the History daemon has processed all records in its queue. Use the History Daemon Monitor (36.14.16.1.3) and the Balance Daemon Monitor (36.14.16.2.3) screens to check the status of the daemons.

## Restrictions

The Statutory-Currency Utility does not use the Inventory exchange rate, even if this rate is defined for the dates of all posted transactions in the domain. This restriction means that, if Inventory exchange rates are used, you must revalue the inventory balances so that the statutory currency balance is equal to the base currency balance multiplied by the Inventory exchange rate. You may also need to restate purchase order price variances for the same reason.

**Note** Running the Statutory-Currency Utility is an intrusive operation, and it is recommended that you run the utility in a test environment first. It is also recommended that you make a backup of the database before running the utility.

## Command Line Application Control

The application control program, `applicationcontrol.p`, can be used to start and stop applications and daemons (except the Report daemon), and to perform a command-line synchronization. This program lets you perform application maintenance from the command line, without launching the application interface.

The application options include the ability to start the application with or without housekeeping, which deletes inactive data from the database. The Synchronize options include the ability to synchronize all or specific application components

The command line syntax for `applicationcontrol.p` is:

```
_progres -p applicationcontrol.p -param <options> -b > <LogFile>
```

where `<options>` is a string to pass options to the program, and has the format `-<option> [<value>] [-<option> [<value>]]`.

You can configure the following options:

- URL

Specify the appserver URL with the following syntax:

```
appserver://<HostName>:<NameServerPort>/<AppServiceName>
```

- PROPATH

Indicate the propath to be used by the `_progres` session in cases where the logic is run in the process itself rather than on the central appserver. You indicate the propath when you have not specified an appserver URL.

- ACTION

Specify an action to be performed. The `<value>` string can be one of the following:

```
StartApplication
StartApplication_no_housekeeping
StopApplication
StopApplication_no_wait
StartDaemon [<DaemonName>]
```

Use this option to start a new instance of the named daemon. If you do not specify a daemon, the system starts all configured daemons.

```
StopDaemon <DaemonName>
```

This option sends a stop request for all instances of the named daemon.

```
DaemonStatus [<DaemonName>]
```

This returns status information for the named daemon, for example:

```
Daemon Name:                XmlDaemon
[Status] Status:             Active
[Status] #Running instances: 2
[Status] Proces Ids:         1884, 4856
[Status] Start date of daemon:04/12/2007
[Config] Log file:           /users/xyz/logs/xmldaemon.log
[Config] Startup folder:     /users/xyz/daemons/xmldaemon
[Config] Daemon login:       user
[Config] XML input folder:   /users/xyz/daemons/
                             xmldaemon/input
ResetDaemonConfiguration [<DaemonName>]
```

**Note** If the daemon is not specified, the system returns the status of all defined daemons in the system

```
ResetDaemonConfiguration [<DaemonName>]
```

By default, this resets all daemons, but by specifying a Daemon name as an extra parameter, it can be limited to one daemon only.

Use `ResetDaemonConfiguration` when you are copying an application database from one environment to another. This ensures that daemon configurations are reset to initial values, and prevents daemons from using previous.

By default, this resets all daemons, but you can limit the reset to a single daemon by specifying the daemon name as an extra parameter.

```
Synchronize [Full|Limited|Topic<XX>]
```

This performs a full or limited synchronization, or for specified topics.

Each topic is represented by a topic number, as listed in Table 9.3. The Synchronization Type column indicates if the topic is automatically included in limited or full synchronizations if you do not specify it by number.

**Table 9.3**  
Synchronization Topic List

Synchronization Topic	Topic Number	Synchronization Type
Languages	1	LIMITED
Areas, Classes, and Activities	2	FULL
Default Activities	3	FULL
Shared Set Types	4	LIMITED
Stored Searches Defaults	5	FULL
Superuser Role	6	FULL
Report Strings	7	FULL
Daemons	8	FULL
Settings Configuration	9	FULL
Users	10	LIMITED
Default Entity	11	FULL
Translations	12	FULL
System	14	FULL
Resources	15	FULL
Default Roles	16	FULL
GL Types	101	LIMITED
Daybook Types	102	LIMITED
Profile Types	103	LIMITED
Exchange Rate Types	104	LIMITED
Address Types	106	LIMITED
GL System Types	107	LIMITED
Currencies	108	FULL
Business Relations	109	FULL
SAF Concept	110	LIMITED
Countries	111	FULL
Rounding Methods	112	FULL
Domains	113	FULL
China Accounting Interface Reports	114	FULL
China Accounting Interface Filter	115	FULL

Synchronization Topic	Topic Number	Synchronization Type
Bank Account Validations	116	LIMITED
Non Taxable Tax Group	117	LIMITED

**Example** Use the following command to run the application installed to the directory `C:\qad2008` and to check the status of the XML daemon running on this server. You must include the `\lib` and Progress procedure library directories in the `propath`. The command displays the command results in the log file `vek.log`.

```
_progres -p applicationcontrol.p -param "-PROPATH
C:\qad2008\fin\lib,C:\qad2008\fin\qadfin.pl -ACTION DaemonStatus[xmldaemon]" -b >
vek.log
```



# Customizing Business Logic

This chapter describes the principles and techniques for customizing the business logic of a component-based QAD application.

***Introduction to Customization* 220**

Gives a customization overview.

***Elements of Customization* 221**

Discusses parameters, datasets, error handling, database access and updates, inheritance, and identifying events.

***Accessing Generalized Codes and Master Comments* 224**

Describes how to access generalized codes and master comments from the customized code.

***Creating Customizations* 231**

Explains how to write customizations, compile customizations, update customizations, and run other business methods, and gives examples of customization.

## Introduction to Customization

You can customize component-based QAD applications after installation in a number of ways:

- By using the Design Mode feature to customize the user interface during run-time
- By creating user-defined fields and adding them to the interface
- By customizing business component code using a standard Progress editor

These first two options let the user or developer add fields and modify forms in the current UI. You can also use built-in .NET features to customize components such as searches, browses, and reports. These options are described in Chapter 12, “UI Customization,” on page 249. For more information on browses and stored searches, see *Introduction to QAD Enterprise Applications User Guide*.

See Chapter 11, “Customizing Specific Business Components,” on page 235 for information on customizing the matching logic for Processing Incoming Bank Files and customizing tax ID validation.

This appendix describes how to customize business component code for an installed application using a standard Progress 4GL editor.

### Customization Overview

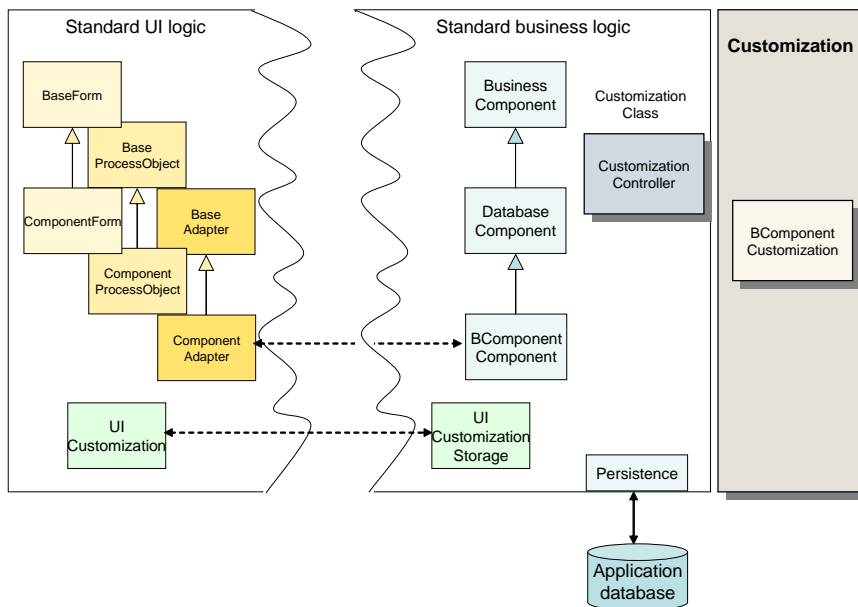
QAD application component code is based on a standard code template, and you can create customizations for the following standard application activities:

- Creating an object
- Modifying an object
- Deleting an object
- Browsing an object
- Generating a report
- Retrieving data for a field into the object form
- Retrieving related activities for an activity

You customize any of these activities by writing code that is activated with a publish-subscribe mechanism, in which a customized event is published before or after the component code. A code template (`BComponent.p`) is provided for each business component, which contains the procedure definitions for every before or after event that can be customized, and which you use to implement the customization. The template code is commented, and to hook the event code into the component process, you uncomment the event and add the necessary component code. This process is called *non-intrusive* customization, because the customized code is added before or after the standard code, but does not intrude on the standard code itself. Template code does not contain any application framework code, but does contain descriptions of methods and method parameters.

Each component-based application also contains a customization controller class `CustomizationController`. This class controls the available customization pieces and their implementation, and ensures that the correct customized code is executed in the right order for the different processes.

**Fig. 10.1**  
Component Customization



Customizations are run on the same appserver as the internal code, and are portable from one application instance to another. You can also call standard methods and queries from within customized code.

## Supporting Documentation

When customizing, you can refer to the QAD Financials API documentation for information on activities, queries, and methods for components.

The API documentation is provided in HTML format with each QAD Enterprise Financials release. It is stored in the `HTMLdocumentation` folder in your installation directory in a file called `QADFIN_Documentation.zip`.

The API documentation represents the documented class model for the application business layer, and is written by QAD developers.

See “Tables and Mandatory Fields” on page 131 for more information. In addition, the API documentation is described in detail in the *Best Practices for Customization* training course.

QAD Support can also provide details on integrating with Financials using APIs on the following topics:

- General Information
- Supplier Invoice and Matching
- Tax Calculation / GTM

## Elements of Customization

The following section describes the code elements used in non-intrusive customization.

## Parameters

The parameters of all business methods are stored in the temporary table `t_Parameter`. To access a parameter, you use the field of the same name in `t_Parameter` table. The `t_Parameter` table always contains exactly one available record, which means that you do not need to use `find` or `for each` when using the table. When you assign a value to a field in the table, this value is retrieved at runtime by the standard business code.

You typically assign a value to an input parameter in a *before* event, and assign a value to an output parameter in an *after* event. A value assigned to an output parameter in an *before* event can be overwritten by the standard business logic.

**Example** The following example uses the input parameter `icPkeys`.

```
/**/
PROCEDURE BItem.DataLoad.before:
if t_Parameter.icPkeys <> ""
then t_Parameter.icPkeys = t_Parameter.icPkeys + chr(4) + "MyKey".
/* load something extra */
END PROCEDURE.
/**/
```

## Datasets

All datasets available to the standard business logic are also available to the customization code. These are not just copies of these datasets, but are direct bindings, which means that any dataset changes you make go directly to the standard business logic.

### Class Datasets

Each business component has a set of class tables grouped in a class dataset. These tables are used to update the application database. Database updates are first prepared in the class tables, then validated, and when correct, are written to the application database.

Each business component has three class datasets:

- `<classname>O` (tables `t_o<databasetablename>`)  
Records in this dataset are updated by the business logic. These values are written to the application database.
- `<classname>I` (tables `t_i<databasetablename>`)  
Records in this dataset represent values read from the database (used for optimistic lock checking), and must not be modified.
- `<classname>S` (tables `t_s<databasetablename>`)  
Records in this dataset represent the input data of business functions that use the class dataset for input parameters (for example, `SetPublicTables`). These records are first validated and, when correct, are copied into the `<classname>O` dataset. This means that all business validation rules are written to use this dataset.

A buffer `t<databasetablename>` is available in all components that represents the `t_o<databasetablename>`. This makes programming easier and more readable. Since the code is working with the `t_o` data in most methods, it can be used in most cases, except for the `Validate*` methods, in which the `t_s` data is worked on.

## Class Tables

Each class table contains the fields `tc_Rowid` and `tc_ParentRowid`. They are used to define a generic relation between tables of the class dataset:

```
<childtable>.tc_ParentRowid = <parenttable>.tc_Rowid.
```

**Important** You must not change the value of these fields. Check the documentation of each business component individually to establish the relations between class tables.

Each class table also contains the field `tc_Status`. The value of this field defines the kind of update that is performed on the database, and can be one of the following:

- (empty)
 

The record is identical to the record in the database. It is ignored when the database is updated. If you do make changes to the record but forget to set the value of `tc_Status`, your changes are not written to the database.
- 'N' (new)
 

Records with this status are created in the database. Do not use a `create` statement to add records in the class dataset. Instead, use the business function `AddDetailLine` which assigns correct default values to the newly created record.
- 'C' (change)
 

Records with this status are updated in the database. The record to update is retrieved using the value of `tc_Rowid`, instead of the primary key fields. This does not mean that primary key fields can be modified, as these fields may be copied into related tables, and by modifying them, you break the link to those tables.
- 'D' (delete)
 

Records with this status are deleted in the database. The record to delete is retrieved using the value of `tc_Rowid`. If the table is the parent of table relations with delete constraint 'cascaded', related records are deleted as well.

## Class Data Items

Each class also contains a set of data items, which are used in the internal business logic of the component. You can examine and update these data items using the generic `Get<DataType>Item` and `Set<DataType>Item` methods, where `<DataType>` is one of the following:

- Character
- Decimal
- Integer
- Int64
- Logical
- Memptr

- Longchar
- Raw
- Recid
- Rowid
- Handle
- ComHandle

These methods are only generated when at least one class data item of the respective data type is defined for the component.

The logic includes a preprocessor variable called `&USEDATAITEMS`, which is available to all code. This preprocessor is a comma-separated list of data item names, and is passed in the include file reference definition/`<component include file name>` in the custom code program. For example:

```
{definition/bsaf.i &USEDATAITEMS = "viDataItem"}
```

It is the responsibility of the custom code developer to populate the `&USEDATAITEMS` variable with custom code. Data items not added to the preprocessor will not be available in the custom code.

The following conditional code defines a variable to mirror a data item:

```
&IF LOOKUP("viDataItem","{&USEDATAITEMS}") > 0
&THEN
  DEFINE VARIABLE viDataItem AS INTEGER NO-UNDO.
&ENDIF
```

The following conditional code calls the `setDataItem` and `getDataItem` methods:

```
Procedure GetDataItems:
  Define variable vc as character no-undo.
  &IF LOOKUP("viDataItem","{&USEDATAITEMS}") > 0
  &THEN
    Run GetIntegerItem (input "viDataItem", output viDataItem).
  &ENDIF
End procedure.
Procedure SetDataItems:
  Define variable vc as character no-undo.
  &IF LOOKUP("viDataItem","{&USEDATAITEMS}") > 0
  &THEN
    Run SetIntegerItem (input "viDataItem", input viDataItem).
  &ENDIF
End procedure.
```

## Accessing Generalized Codes and Master Comments

### Generalized Codes

You can define user-defined fields with a lookup or value list based on generalized codes. See “Create a User-Defined Field” on page 266.

You can also use non-intrusive customization to add a lookup to a field based on generalized codes.

#### **Example**

```
procedure bbusinessrelation.getbusinessfields.after:
```

```

find tBusinessFields where
    tBusinessFields.tcFcFieldName = "tAddress.AddressZip"
no-error.

if available tBusinessFields
then assign tBusinessFields.tcLookupQuery =
"BMfgGeneralizedCodeSAO.SelectGeneralizedCode"
    tBusinessFields.tcLookupFilterField = "tcode_mstr.code_value"
    tBusinessFields.tcLookupReturnField = "tqSelectGeneralizedCode.tccode_value"
    tBusinessFields.tcRelatedObject = "<Generalized Code you need>".
end procedure.

```

## Master Comments

You can access master comments from the customized code using the `GetComment` method, included in every business component. The `GetComment` method queries the `cd_det` table or the `cmt_det` table, or both, depending on the parameters you specify.

## Error Handling

### Application Errors

Error messages to the end-user can be created by running the `SetMessage` procedure in combination with the parameter `oiReturnStatus`.

An error condition is raised when you assign a negative value to `t_Parameter.oiReturnStatus`. When this occurs, standard business logic stops executing and passes the return status to the client that runs the business logic.

**Note** The `ValidateComponent` and `ValidateBC` methods are exceptions to this behavior. When the return value for `oiReturnStatus` is negative, these methods continue to execute and attempt to validate the component.

The possible values for `oiReturnStatus` are:

- -1 Validation error  
The input for the operation was incorrect. The operation could not proceed.
- -3 Run-time error  
The operation did not proceed because of a run-time error in the operation code.
- -5 Fatal error  
The operation did not proceed because of a permanent error. The application is shut down.

### System Errors

System errors are triggered by Progress run-time when a Progress statement without the `no-error` option fails to execute. System errors are handled by the standard business logic using the new try-catch mechanism of OpenEdge 10. You must then ensure that any sub-transaction block (for example, a `do` transaction, `for`, or `repeat` block) in your code includes the `on error undo, throw` option.

System errors are reported using `oiReturnStatus -98`.

You can also add a `finally` block at the end of a customization event procedure. Code in a `finally` block is always executed before the procedure ends. It is also run when a system error occurs during the execution of a procedure or if the code is interrupted with an explicit `return` statement.

## Database Access and Updates

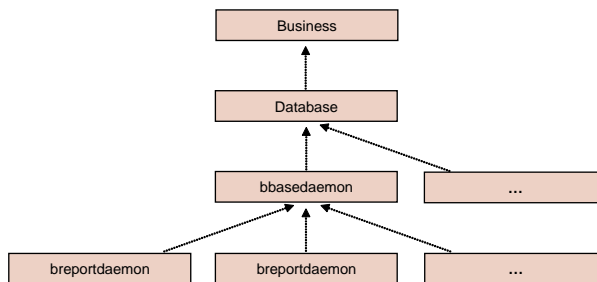
There are no rules or restrictions on database access and updates. Each event is a transaction on its own and all updates to it are committed when the event ends. The exceptions to this are the events on the business method `DataSaveWorker` and the sub-methods `PreSave` and `PostSave` (see “Identifying Events” on page 226). These methods are typically contained in larger transactions, and updates to them are not implemented if the larger transactions fail.

## Inheritance

When you implement an event on a business component that has descendant business components, the event is also implemented for all the descendants, except descendants that override the standard business logic for that specific method.

### Example

**Fig. 10.2**  
Inheritance Structure



Any customization event implemented on `bbasedaemon` is active when running the component `bxmldaemon`, `breportdaemon` or any other daemon.

## Identifying Events

To view the execution flow in full detail, use the system logging functions. Set Debug Level (36.24.3.5) lets you set the level of detail displayed in the system `ctlog` file. You can display full business code, including parameter values and database queries.

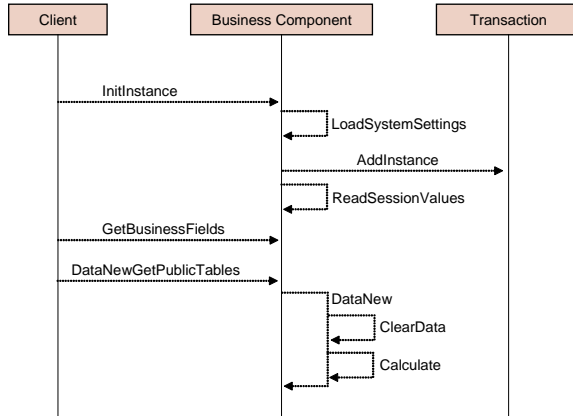
When logging is enabled, you can run the function you want to customize, and then display the execution flow in `ctlog`. The log displays the business methods used in the function and how they are implemented.

See “Set Debug Level” on page 151.

The following business logic flows illustrate the call stack of some of the most used business functions.

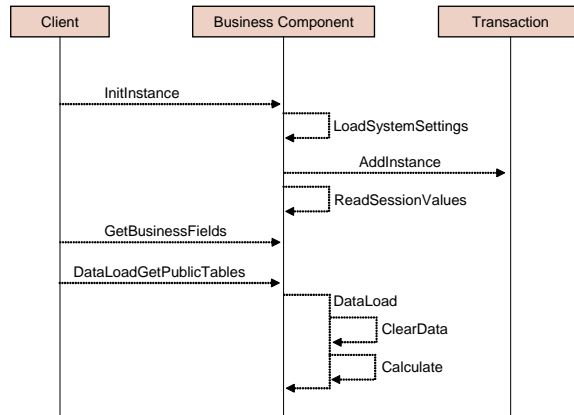
### Instantiate a Maintenance Form in Create Mode

**Fig. 10.3**  
Create Call Stack



### Instantiate a Maintenance Form in Update mode

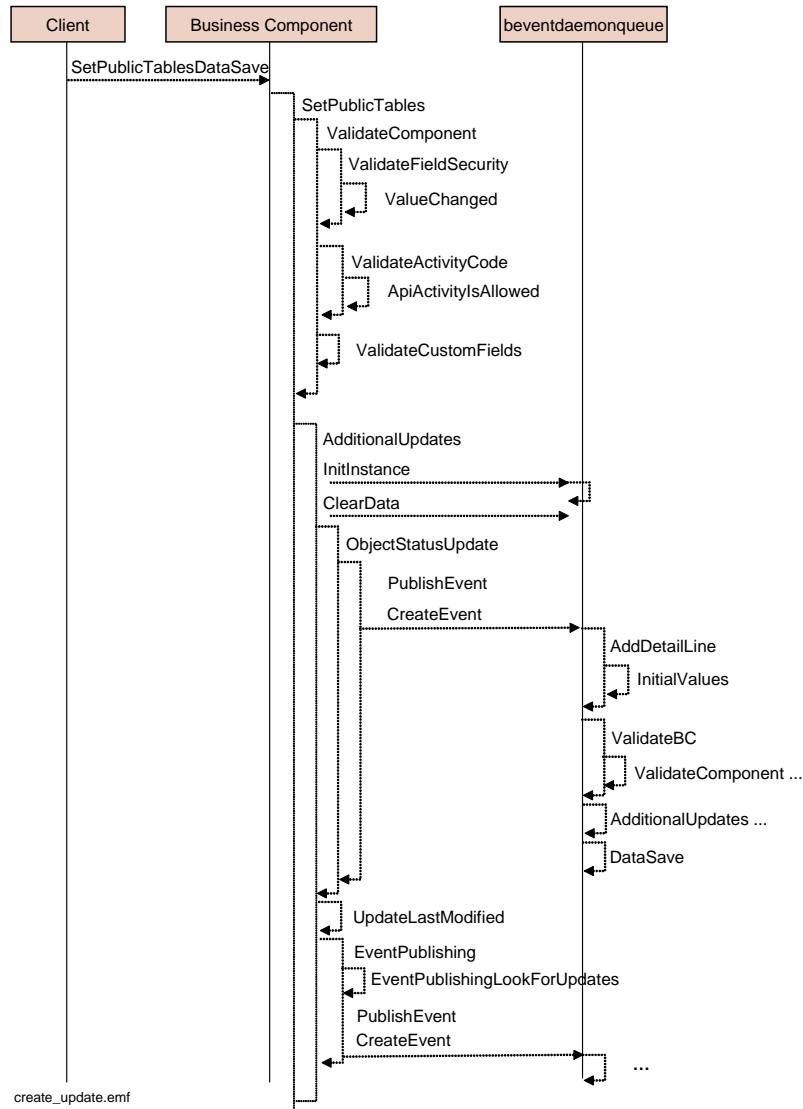
**Fig. 10.4**  
Update Call Stack



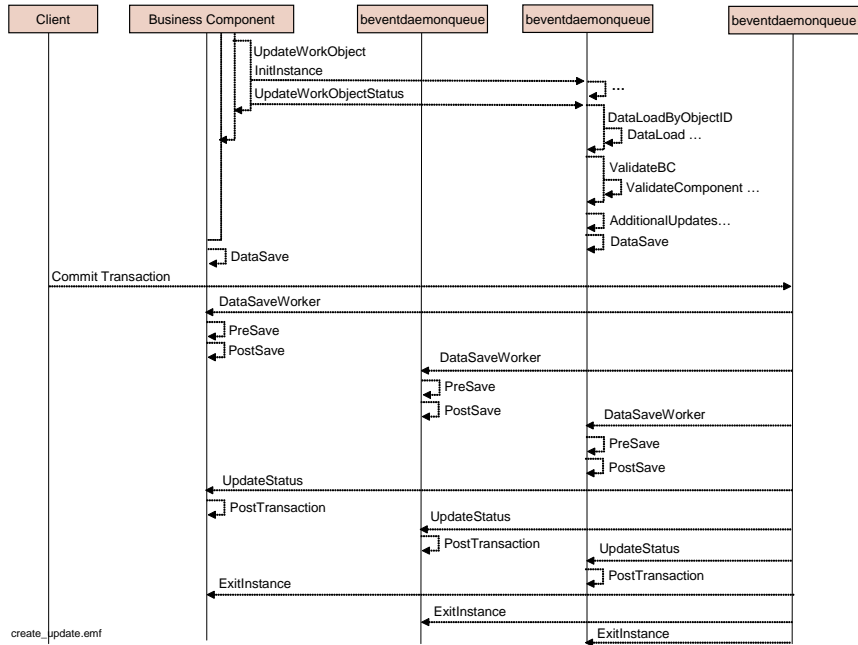
### Save Data in a Maintenance Form (Create and Update)

The following diagrams illustrate the call stack for saving data in a maintenance form.

**Fig. 10.5**  
Save Call Stack

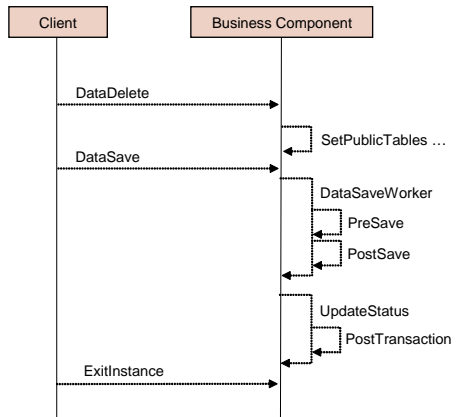


**Fig. 10.6**  
Save Call Stack (contd.)



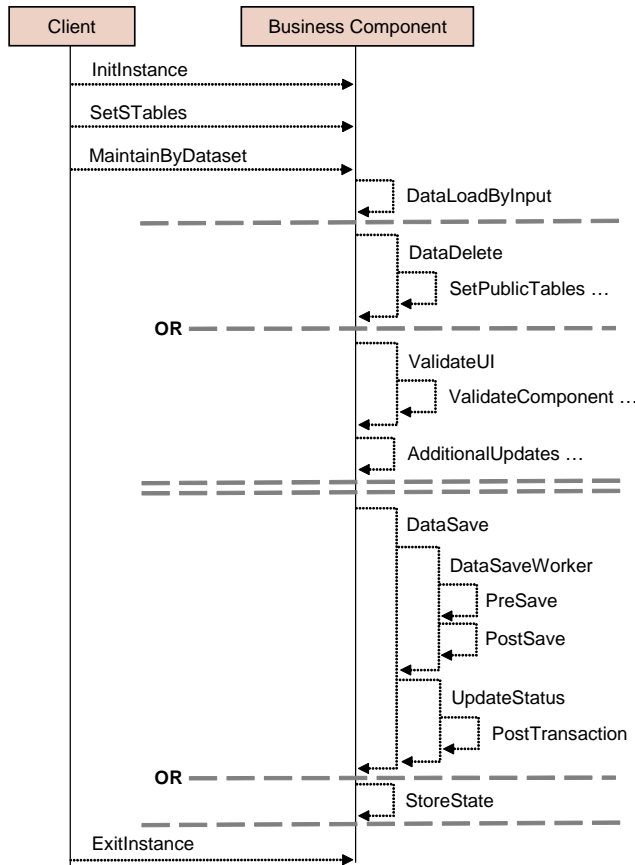
### Deleting an Object in a Maintenance Form

**Fig. 10.7**  
Delete Call Stack



## Importing Data using the XML Daemon

**Fig. 10.8**  
Import Using XML Call Stack



## Sample Code for Non-Intrusive Customization

The following code illustrates the `GetBusinessFields`, `InitialValues`, and `ValidateComponent` methods contained in the customization template file `BLanguage.p`.

```

/*
Procedure: GetBusinessFields
Description:
Return a list of public business fields of a business class.
Parameters:
input icReference
    (business class or (query) method name)
output dataset tBusinessFields
    (business fields)
output dataset tCustomRelation
    ( )
output oiReturnStatus
    (Return status of the method.)
*/
/**
PROCEDURE BLanguage.GetBusinessFields.before:

END PROCEDURE.
**/

```

```

/**
PROCEDURE BLanguage.GetBusinessFields.after:

END PROCEDURE.
**/

/*
Procedure: InitialValues
Description:
Add code here to initialize the calculated fields of a 'new' record (= a record that must
be created in the application database) in a class temp-table.

Parameters:
input icTableName
    (Name of the database table of which a record is created in the class temp-table.)
output oiReturnStatus
    ()
*/
/**
PROCEDURE BLanguage.InitialValues.before:

END PROCEDURE.
**/
/**
PROCEDURE BLanguage.InitialValues.after:

END PROCEDURE.
**/
/*
Procedure: ValidateComponent
Description:
Write here all tests on database update (new / modify / delete) that cannot be coded with a
validation mask.
The type of update can be found in tc_status (N/C/D).
If you find incorrect data, you must write an entry in tFcMessages (using SetMessage) and
set the return status of this method to either +1 or -1.
Return status +1 = data will still be accepted.
Return status -1 = data will not be accepted.
This method is run from SetPublicTables, before transferring the received data into the class
temp-tables.
Parameters:
output oiReturnStatus
    ()
*/
/**
PROCEDURE BLanguage.ValidateComponent.before:

END PROCEDURE.
**/
/**
PROCEDURE BLanguage.ValidateComponent.after:

END PROCEDURE.
**/

```

## Creating Customizations

Before and After events are provided for every method of the business component, and each event header describes the business method and its parameters. To customize the event, you uncomment the event you want to implement and add code into the internal procedure.

The Customization folder in the application root contains two sub-folders:

- Definition
  - This folder contains an include file for each business component.
- Template

This folder contains the .p program file for each business component. This program contains the Before and After event code for the component.

**Note** You must include the Template folder in the PROPATH of each progress session used for compiling the customized component code. This ensures that the system can detect code version mis-matches during an application upgrade.

## Writing Customizations

Use the following steps for every component that you want to customize.

- 1 Copy the file in the template folder to a local source code folder.  
You must always code in a locally stored copy of the template file, and not in the original file. You can store this copy anywhere on your local drive, but you must ensure that you copy only those template files that you are modifying. Ensure that the local folder you use is contained in the PROPATH for compilation.  
You also copy the include file from the definition folder to the local folder. This file is needed for compilation, and must not be modified.
- 2 Use a Progress 4GL editor to uncomment the events in the template file to be customized, and to add related code.

## Compiling Customizations

Compile all program files in your local source code folder into a folder named `customcode`.

This `customcode` folder is placed in a folder that is part of the PROPATH of the appserver running the business logic.

Once the folder is included in the PROPATH, the application automatically runs the customization when the appserver is restarted or all agents are trimmed.

## Updating Customizations

Whenever a new version of the application is installed, the customized programs in your local source code folder must be updated to the new version. In most cases, you can update the version number in the header of the program (`&scoped-define class-version xx.yy`) to the version number displayed in the new template folder. If the template file has undergone many changes since the previous version, it may be more useful to copy the template file and add your customizations again.

When you have reinstalled the application, you must compare the methods in your customizations with those contained in the new template files, because methods may change with every new version.

You must also evaluate the method descriptions and parameters, because parameters can also be removed between installations. You must resolve any differences before you continue with customization. Use a standard file diff tool to make your comparisons.

## Running Other Business Methods

You can run any customizable procedure from within the customization, using a standard run statement.

The procedure itself can be customized or standard. The procedure is run within the standard business component through procedure overloading.

**Example** In this example, you run the method `GetCustomFieldList` from within a customization of `BItem.ValidateCustomFields`:

```
/**/
PROCEDURE BItem.ValidateCustomFields.before:
    define variable vcList as character no-undo.
    define variable viReturn as integer no-undo.
    run GetCustomFieldList (output vcList, output viReturn).
END PROCEDURE.
/**/
```

## Examples of Customization

This section describes some sample customizations.

**Example** Customize the default value for `GLExchangeMethod` when creating a G/L account:

```
/**/
PROCEDURE BGL.InitialValues.after:

    /* tgl is a shared buffer on table t_ogl */
    if t_Parameter.icTableName = "gl"
        then assign tgl.GLExchangeMethod = "USERDEFINED".

END PROCEDURE.
/**/
```

**Example** Add default values for SAF codes when creating a G/L account:

```
/**/
PROCEDURE BGL.InitialValues.after:

    define variable viReturn as integer no-undo.

    if t_Parameter.icTableName = "gl"
        then do:

            /* AddDetailLine will create a record in tGLSafDefault */
            run AddDetailLine (input "GLSafDefault",
                input tgl.tc_Rowid,
                output viReturn).

            /* parent rowid */
            /* error handling */
            if viReturn < 0
                then assign t_Parameter.oiReturnStatus = viReturn.
            else assign tGLSafDefault.GL_ID = tgl.GL_ID
```

```

        tGLSafDefault.tcSafConceptCode = "<CustomValue>"
        tGLSafDefault.tcSafCode = "<CustomValue>".
    end.
END PROCEDURE.
/**/

```

**Example** Add a custom table to a report dataset:

```

/* define the custom table */
define temp-table glhistoryCustomData no-undo
    field MyCustomCode as character
    field MyCustomValue as character
    index ip is primary unique MyCustomCode.

/* create custom data */
PROCEDURE BGLReport.GLHistory.after:
    create glhistoryCustomData.
    assign glhistoryCustomData.MyCustomCode = "demo-code"
        glhistoryCustomData.MyCustomValue = "demo-value".
END PROCEDURE.
/**/

/* publish the custom data */
PROCEDURE BGLReport.ApiProcessReportLogic.after:
    if t_Parameter.icReportName = "glhistory"
        then t_Parameter.ozReportData:add-buffer(temp-table glhistoryCustomData:default-
            buffer-handle).
END PROCEDURE.
/**/

```

# Customizing Specific Business Components

This chapter describes how to customize the standard matching logic in Process Incoming Bank Files and to implement validation for tax IDs using non-intrusive customization.

***Customizing Process Incoming Bank Files* 236**

Introduces the concept of customizable matching logic for Process Incoming Bank Files. Uses flows and sequence diagrams to illustrate how the matching logic in Process Incoming Bank Files can be customized.

***Customizing the Validation of Tax IDs* 245**

Describes how to use non-intrusive customization to implement the validation of federal and state tax IDs.

## Customizing Process Incoming Bank Files

You can use the Process Incoming Bank Files function (31.1.6) to import bank payment files from your bank, and to generate and allocate customer and supplier payments and banking entries in the system using the transaction messages contained in the files.

The Enhanced Lockbox module exposes the standard matching logic for the Process Incoming Bank Files function. This matching logic is used to match customer and supplier payments in the imported bank files to open items on the system.

The customizable matching logic uses the following customizable methods:

- `BankImpLine.GetInvoicesByBankImpLine.Before`
- `BankImpLine.GetInvoicesByBankImpLine.After`
- `BankImpLine.GetInvoicesByBankImpLineXref.Before`
- `BankImpLine.GetInvoicesByBankImpLineXref.After`
- `BankImpLine.GetCDocumentByBankImpLine.Before`
- `BankImpLine.GetCDocumentByBankImpLine.After`
- `BankImpLine.GetDDocumentByBankImpLine.Before`
- `BankImpLine.GetDDocumentByBankImpLine.After`
- `BankImpLine.GetCreditorByBankImpLine.Before`
- `BankImpLine.GetDebtorByBankImpLine.Before`

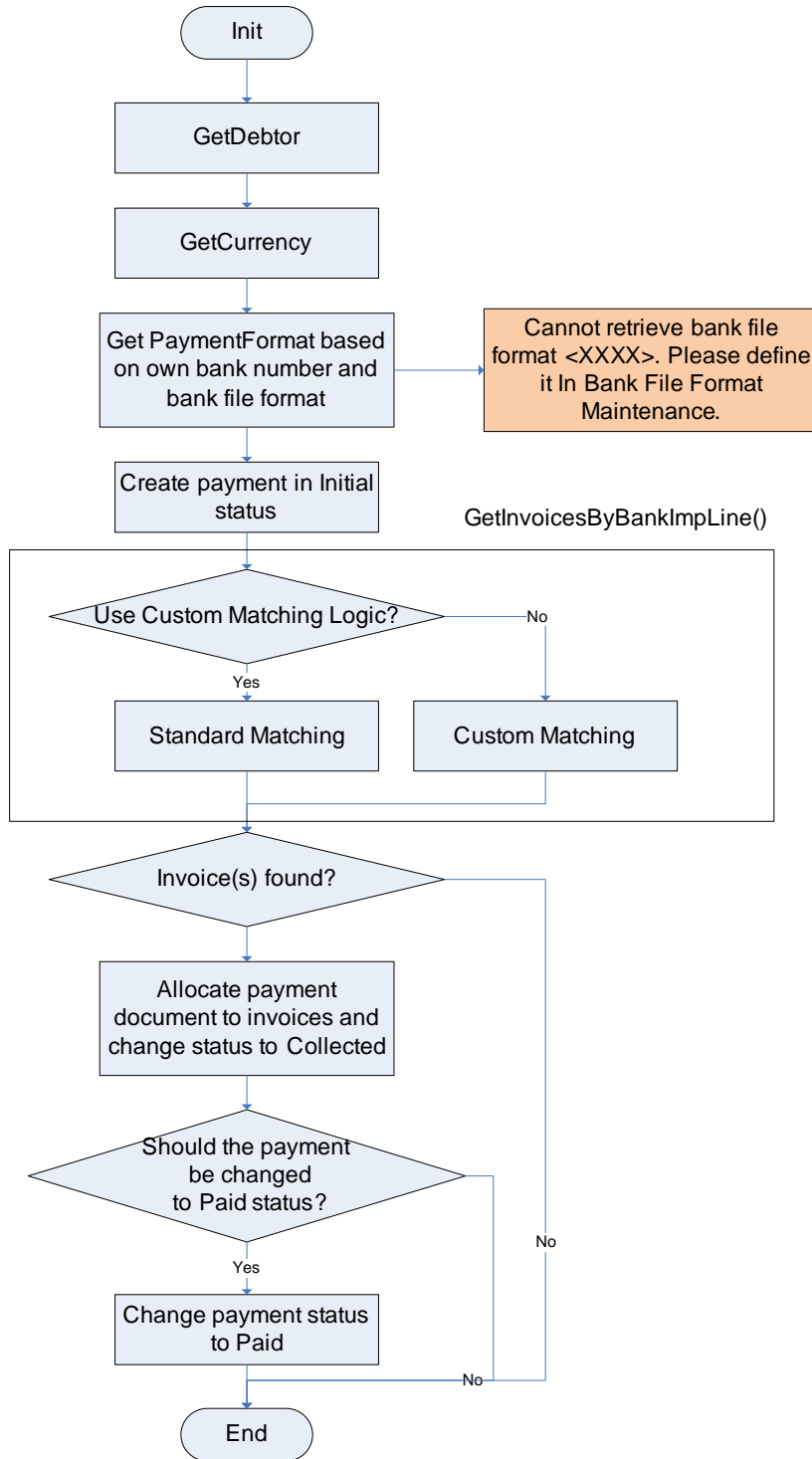
The customizable matching logic is similar to the standard matching logic, and can be enabled and disabled using the customization template file, `bbankimpline.p`.

### Customer Payments in Bank File Import Lines

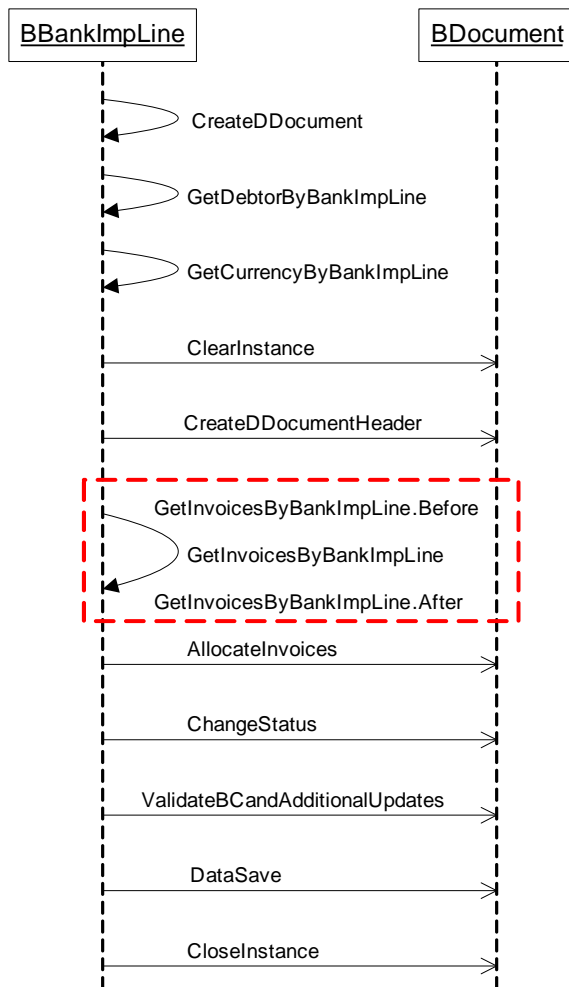
This section contains flows and sequence diagrams to indicate how Process Incoming Bank Files processes customer payments. It also describes the variable you use to activate the customizable matching logic.

Figure 11.1 shows the customer payments flow and indicates the point at which the matching logic is used.

**Fig. 11.1**  
Customer Payments, Main Flow



**Fig. 11.2**  
Customer Payments Flow—Sequence Diagram



### BankImpLine.GetInvoicesByBankImpLine.Before()

In order to use the customizable matching logic instead of the standard matching logic, set the `vlUseCustomMatching` variable to `Yes` in the `GetInvoicesByBankImpLine.Before` method. To disable the customizable matching logic, set the variable to `No`.

In the non-intrusive framework, a standard method variable cannot be shared with its `.Before` or `.After` method. Therefore, the `vlUseCustomMatching` variable is defined at class level, and the program calls the `SetPublicData` and `GetPublicData` methods to store and retrieve class variables.

```

PROCEDURE BBankImportLine.GetInvoicesByBankImpLine.before:
    DEFINE VARIABLE viReturn AS INTEGER NO-UNDO.
    DEFINE VARIABLE vcCustom AS CHARACTER NO-UNDO.
    DEFINE VARIABLE vlUseCustomMatching AS LOGICAL NO-UNDO.
    /* ===== */
    /* if using custom matching logic, return directly without executing standard matching logic.
    */
    /* ===== */
    ASSIGN vlUseCustomMatching = YES.
    ASSIGN vcCustom = IF vlUseCustomMatching THEN "true":U ELSE "false":U.
    RUN SetPublicData(INPUT "vlUseCustomMatching", INPUT vcCustom, OUTPUT viReturn).
END PROCEDURE.
  
```

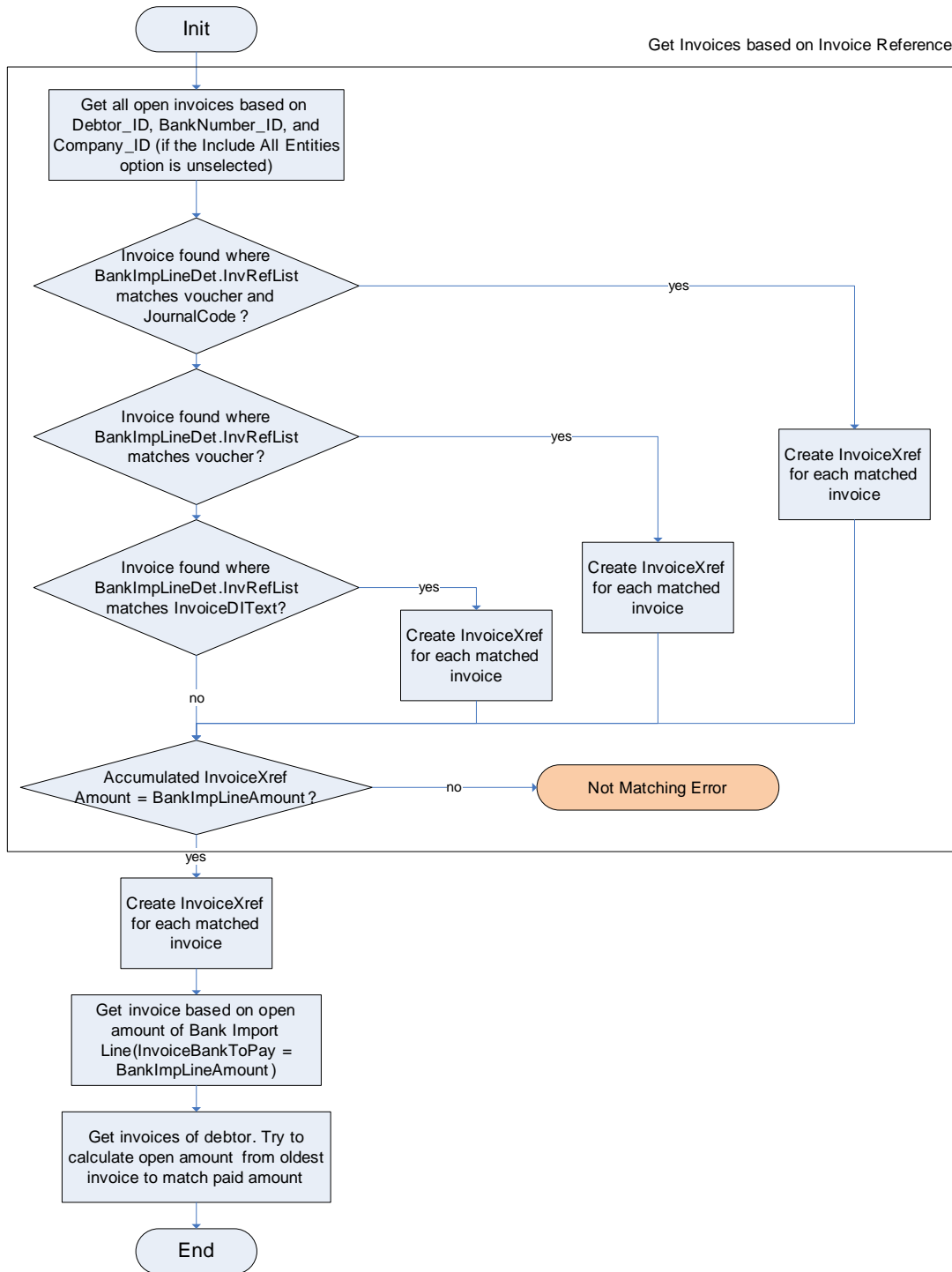
### **BankImpLine.GetInvoicesByBankImpLine()**

The `BankImpLine.GetInvoicesByBankImpLine()` method stores the standard matching logic. If the `vlUseCustomMatching` method variable is set to `Yes`, the program does not execute the standard logic in the method, and continues to execute the `.After` method.

### **BankImpLine.GetInvoiceByBankImpLine.After()**

If the `vlUseCustomMatching` method variable is set to `Yes`, the program executes the customizable matching logic in the `.After` method and its sub method `BBankImpLine.GetInvoicesByBankImpLineXref`.

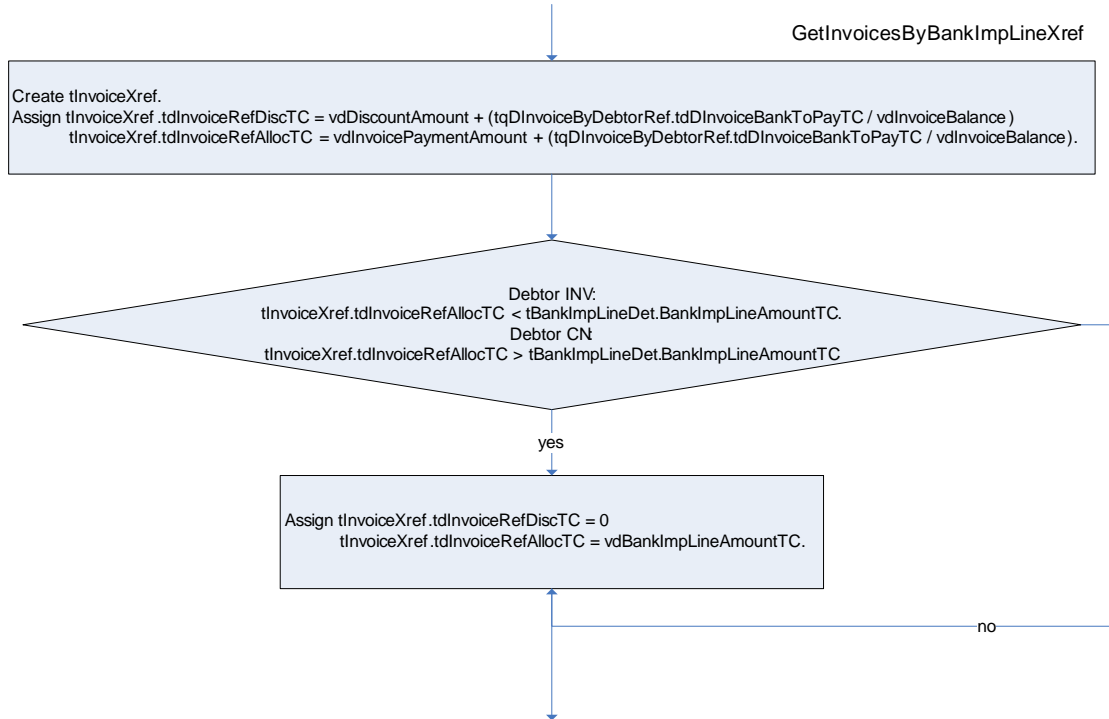
**Fig. 11.3**  
GetInvoices, Main Flow



### BankImpLine.GetInvoicesByBankImpLineXref

The `BBankImpLine.GetInvoicesByBankImpLineXref` method creates invoice cross-references used to allocate invoices to payments. This method has a similar customization structure to the `BBankImpLine.GetInvoicesByBankImpLine.Before` and `BBankImpLine.GetInvoicesByBankImpLine.After` methods.

**Fig. 11.4**  
GetInvoicesByBankImpLineXref, Main Flow



The `BBankImpLine.GetInvoicesByBankImpLineXref` method also controls the allocation of partial customer payments. If partial payments are enabled and if the bank file contains a customer open item with a matching daybook and voucher reference, and the bank file import amount is less than or equal to the open invoice amount, the bank import line payment amount is applied against the open item.

You can disable partial allocation by commenting out the following code:

```

/* if tDInvoiceByDebtorRef.tdDInvoiceOriginalDebitTC -
tDInvoiceByDebtorRef.tdDInvoiceOriginalCreditTC > 0
then do:
  if tBankImpLineDet.BankImpLineAmountTC - tInvoiceXref.tdInvoiceRefAlloTC < 0
  then do:
    assign tInvoiceXref.tdInvoiceRefDiscTC = 0
           tInvoiceXref.tdInvoiceRefAlloTC = tBankImpLineDet.BankImpLineAmountTC
           tInvoiceXref.tdInvoiceRefAlloTC = dynamic-
function("RoundAmount", tInvoiceXref.tdInvoiceRefAlloTC, ?,
tDInvoiceByDebtorRef.tcCurrencyCode).
    end.
  end.
else if tDInvoiceByDebtorRef.tdDInvoiceOriginalDebitTC -
tDInvoiceByDebtorRef.tdDInvoiceOriginalCreditTC < 0
then do:
  if tBankImpLineDet.BankImpLineAmountTC + tInvoiceXref.tdInvoiceRefAlloTC > 0
  then do:
    assign tInvoiceXref.tdInvoiceRefDiscTC = 0
  
```

```

tInvoiceXref.tdInvoiceRefAlloTC = - tBankImpLineDet.BankImpLineAmountTC
tInvoiceXref.tdInvoiceRefAlloTC = dynamic-
function("RoundAmount",tInvoiceXref.tdInvoiceRefAlloTC, ?,
tDInvoiceByDebtorRef.tcCurrencyCode).
end.
end.
assign tInvoiceXref.tdInvoiceRefAlloTC = tInvoiceXref.tdInvoiceRefAlloTC+
tInvoiceXref.tdInvoiceRefDiscTC. */

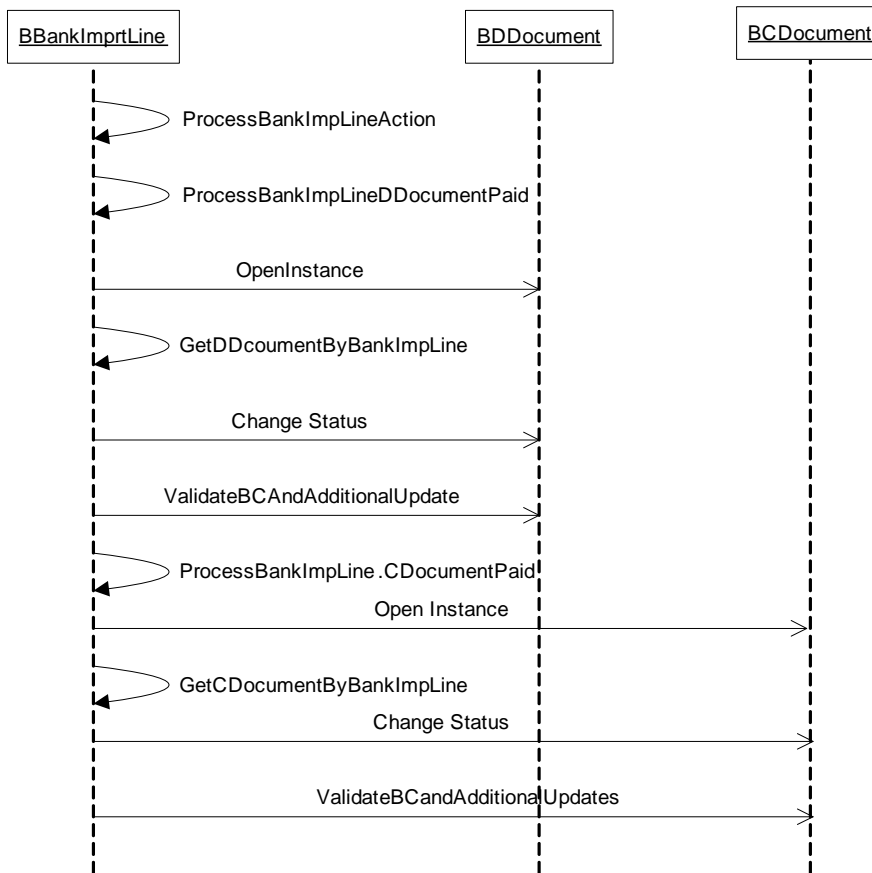
```

### Changing the Customer Payment Status to Paid

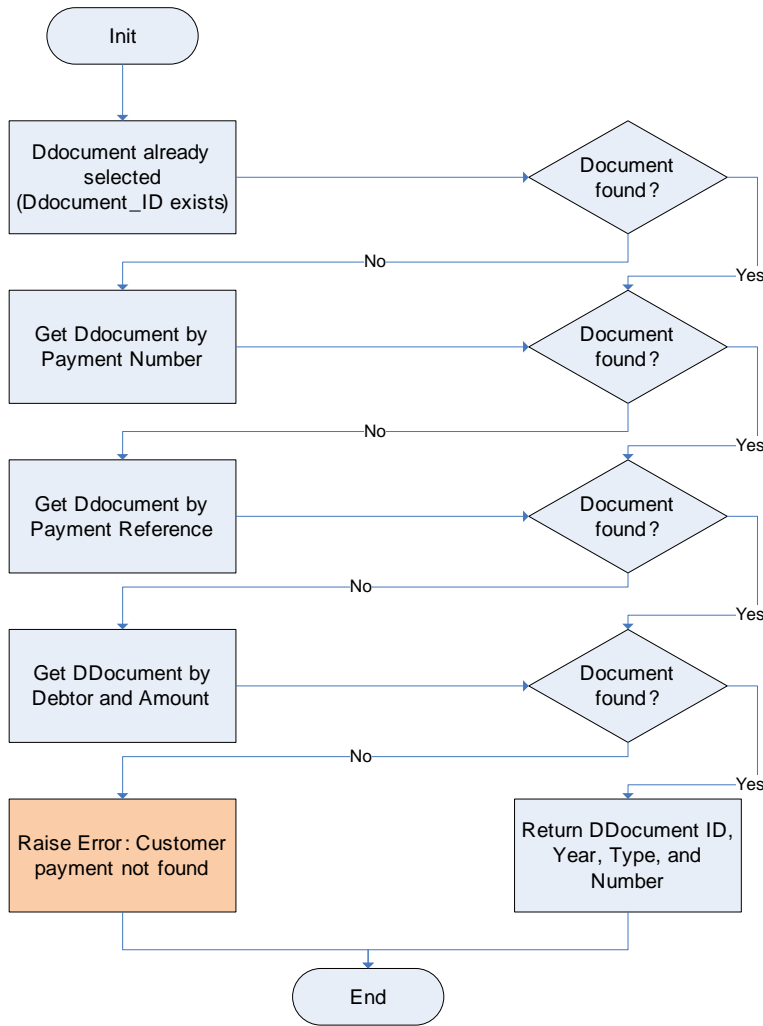
If you want to change the status of a customer payment to Paid, the application calls the GetDDocumentByBankImpLine method to search the DDocument table, which then matches the banking import line.

The GetDDocumentByBankImpLine method has the same customization structure as GetInvoicesByBankImpLine.

**Fig. 11.5**  
GetDDocumentByBankImpLine, Sequence Diagram



**Fig. 11.6**  
GetDDocument, Main Flow



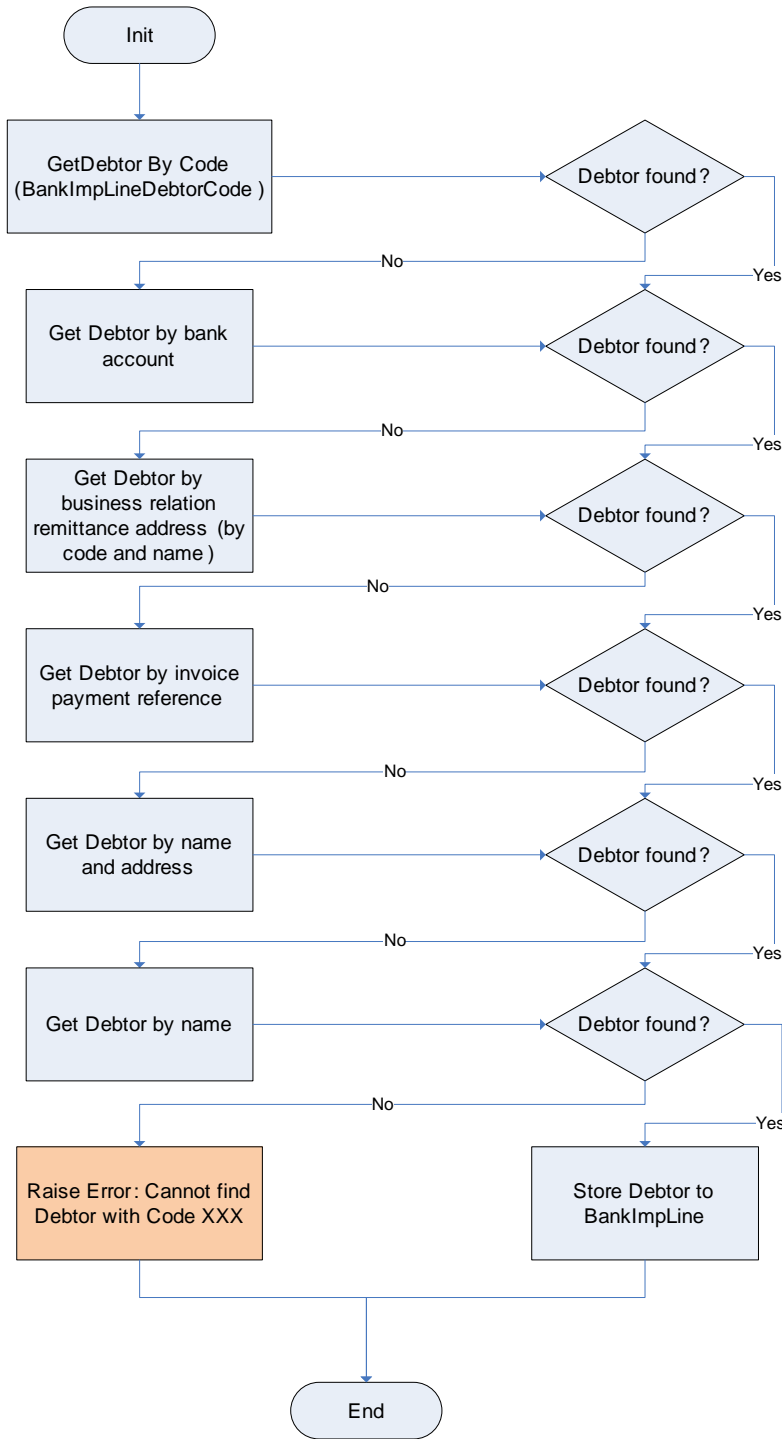
### Changing the Supplier Payment Status to Paid

The `GetCDocumentByBankImpLine` method is similar to the `GetDDocumentByBankImpLine` method, and is used to set supplier payments to Paid.

### Get Debtor

Figure 11.7 illustrates the process used to locate the customer code (debtor code) value in the `GetDebtorByBankImpLine` method.

**Fig. 11.7**  
GetDebtorByBankImpLine, Main Flow



### Get Creditor

The Get Creditor method functions in the same way as Get Debtor, but is used to retrieve the supplier code (creditor code).

## Setting Up Customization

Complete the following steps to install the customizable matching logic.

- 1 Unzip the CustomMatching.zip file (containing `bbankimpline.i`, `bbankimpline.p`, and `build.p`), and add the unzipped files to the `customization` folder on the `c:\` drive.
- 2 Add the `c:\customization` folder to the `PROPATH`.
- 3 Start your QAD application and open System Monitor (36.24.3.4).
- 4 Click Customization and ensure that the customization logic includes the following six `.Before` methods and the following four `.After` methods:
  - `BBankImpLine.GetInvoicesByBankImpLine.Before()`
  - `BBankImpLine.GetInvoicesByBankImpLine.After()`
  - `BankImpLine.GetInvoicesByBankImpLineXref.Before()`
  - `BankImpLine.GetInvoicesByBankImpLineXref.After()`
  - `BBankImpLine.GetCDocumentByBankImpLine.Before()`
  - `BBankImpLine.GetCDocumentByBankImpLine.After()`
  - `BBankImpLine.GetDDocumentByBankImpLine.Before()`
  - `BBankImpLine.GetDDocumentByBankImpLine.After()`
  - `BBankImpLine.GetCreditorByBankImpLine.Before()`
  - `BBankImpLine.GetDebtorByBankImpLine.Before()`
- 5 The `src` folder contains the source code. Open `compile.p` with the Progress Editor, and press F2 to compile the program. The system adds the generated `.r` file directly into the `c:\customization\customcode` folder.
- 6 Trim the appserver. The application then loads the updated `.r` file.

## Enabling and Disabling the Customizable Matching Logic

When the customizable matching logic is installed, the application uses the customizable matching logic by default, and not the standard matching logic.

If you want to disable the customizable matching logic, look for the `assign vcUseCustomMatching = yes.` variable in the `bbankimpline.p` file and replace this with `assign vcUseCustomMatching= no.` in the six `.Before` methods. Do not change the `.After` methods.

## Customizing the Validation of Tax IDs

This section describes how to use non-intrusive customization to implement the validation of federal and state tax IDs according to the requirements of your local tax authority.

You must customize the `BFormatSet` component to implement your custom tax ID validation. `BFormatSet` validates tax IDs entered in the following fields:

- Federal Tax ID field in the Business Relation record
- State Tax ID field in the Business Relation record
- Federal Tax ID field in the Supplier record

- State Tax ID field in the Supplier record
- Federal Tax ID field in the Customer record
- State Tax ID field in the Customer record

In addition, the `BFormatSet` component contains a pre-populated method used to validate the fiscal code used in withholding tax.

**Note** Withholding tax will be available in a forthcoming QAD release.

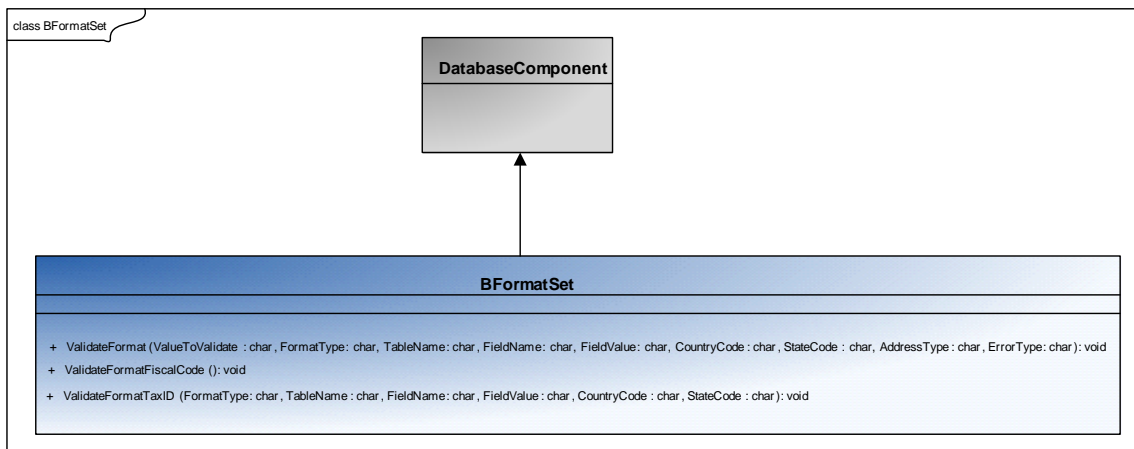
The system passes regional details from the business relation, such as the country code, state, and address type, to the validation component, and these details can be used in the customized tax ID validation.

## Validation Component

The validation component, `BFormatSet`, holds logic for validating tax IDs and fiscal codes. The component is blank, except for the fiscal code validation child method, and exposes the `ValidateFormatTaxID` method, which you can adapt to implement custom tax validations.

**Note** In later QAD releases, you will be able to customize `BFormatSet` to validate other numbers and IDs.

**Fig. 11.8**  
BFormatSet



`BFormatSet` includes the following methods:

- `ValidateFormat`

The parent method for the validations.

Future QAD releases will let you customize the `ValidateFormat` method to validate codes, numbers, or IDs.

- `ValidateFormatFiscalCode`

`ValidateFormatFiscalCode` is a child method that validates the fiscal code used in withholding tax. Withholding tax will be available in a forthcoming QAD release.

- `ValidateFormatTaxID`

`ValidateFormatTaxID` is a child method that validates tax IDs. The method is blank in order for you to customize it and add your own tax validation functionality.

## Errors and Warnings

The Financials code denotes the type of message (Error or Warning) to raise if the tax ID entered by a user fails to validate. This message type is treated as the default by the tax ID customization method, `ValidateFormatTaxID`. However, you can override the default message type using non-intrusive customization.

For example, if the default value is that the system generates an Error message type if the tax ID fails to validate, you can change the message type to Warning using the customization method, even though Error is the default

## Customization Sample Code

The code in this section uses the example of a fictional tax ID validation for the Czech Republic, implemented using non-intrusive customization. In this example, the tax ID cannot be less than two characters.

The `icValueToValidate` parameter supplies the code, number, or ID to be validated. The `icTableName` and `icFieldName` parameters can be used to distinguish between the records to be validated, that is, business relation tax details, supplier tax details, or customer tax details. The `icFieldName` parameter can be used to distinguish between different types of tax ID for the same country, for example, federal or state tax IDs.

```

/* Customization code for component BFormatSet */
&scoped-define class-version 0.0
{ definition/bformatset.i }

/*
Procedure: ValidateFormatTaxId
Description:
This method can be used for validation of correct format of the Tax ID.
- instance less method
Parameters:
input icValueToValidate
    (Code/Number/ID to be validated)
input icTableName
    ()
input icFieldName
    ()
input icCountryCode
    ()
input icStateCode
    ()
input icAddressType
    (Address type.)
input icErrorType
    (Type of error if the format does not comply with the format. (Error/Warning).)
output oiReturnStatus
    (Return status of the method.)
*/

PROCEDURE BFormatSet.ValidateFormatTaxId.after:

define variable viLocalReturn as integer init 0.
define variable viDummy as integer.
assign t_parameter.oiReturnStatus = -98.

MAIN_BLOCK:
do on error undo, leave:
    /* CZECH TAX ID VALIDATION */
    if t_parameter.icCountryCode = "CZE" and

```

```

t_parameter.icAddressType = {&ADDRESSTYPECODESYSTEM-HEADOFFICE}
then do:
  /* If not entered - is OK */
  if t_parameter.icValueToValidate = '' :U or
    t_parameter.icValueToValidate = ?
  then leave MAIN_BLOCK.

  /* First two letters have to be CZ - so length cannot be less than 2 characters */
  if length(t_parameter.icValueToValidate, "CHARACTER") < 2
  then do:
    run SetMessage (
      input 'Czech Tax ID cannot be shorter than 2 characters.',
      /* icMessage */
      input '' :U,
      /* icArguments */
      input t_parameter.icTableName + '.' :U + t_parameter.icFieldName,
      /* icFieldName */
      input t_parameter.icValueToValidate, /* icFieldValue */
      input t_parameter.icErrorType, /* icType */
      input 3,
      /* iiSeverity */
      input '' :U,
      /* icRowid */
      input 'CUSTOM-001' :U,
      /* icFcMsgNumber */
      input '' :U,
      /* icFcExplanation */
      input '' :U,
      /* icFcIdentification */
      input '' :U,
      /* icFcContext */
      output viDummy).
    assign viLocalReturn = (if t_parameter.icErrorType = 'E' :U then -1 else 1).
    leave MAIN_BLOCK.
  end.

  /* Other validations ..... */

end. /* if t_parameter.icCountryCode = "CZE" and */
end. /* MAIN_BLOCK */

assign t_parameter.oiReturnStatus = viLocalReturn.
END PROCEDURE.

```

# UI Customization

The following topics describe how to customize the appearance of screens and add user-defined fields.

**Overview 250**

Introduces UI customization concepts.

**Design Mode 250**

Use Design Mode to add, move, or remove fields and tabs, and modify field properties.

**User-Defined Fields 265**

Customize predefined fields to store data specific to your business requirements.

**User-Defined Components 272**

Define your own business components.

**Financial Text Translation 289**

Explains how to use the Financial Translation Maintenance program to maintain text strings.

## Overview

The component-based user interface supports many ways that users and administrators can tailor it based on your organizational requirements, including the following:

- Customize the user interface using the Design Mode feature.
- Create your own user-defined fields and add them to the user interface using the User-Defined Fields (UDFs) feature.

In addition to the customization of component-based functions, you can modify other aspects of the UI. Which features a particular user can access depends on system and user settings as well as user permissions. See “Configuring System and User Settings” on page 154 for a discussion of settings. For more information on permissions, see *QAD Security and Controls User Guide*.

You can modify browse settings and search results to configure them for your particular needs. The Search options in component functions let you filter your search results in a number of ways, and save customized search settings for reuse. This feature is called a stored search. In addition, you can make a number of modifications to the search results to configure them for your particular needs, such as customizing the column layout. For more information on browses and searching, see *Introduction to QAD Enterprise Applications User Guide*.

You can customize reports in a number of ways by:

- Updating the settings that influence the selection criteria and report output
- Saving specific report settings as a report variant, and reloading them as required, saving time
- Modifying the report layout and saving it as a Crystal Report .rpt file that you and other users can reload and use as required.

For more information on reports, see *QAD Financials User Guide*.

There are many other ways to customize the UI that apply in general, not just to component-based functions. For more information, see *QAD .NET UI Administration Guide*.

## Design Mode

Design mode lets you add, move, or remove fields and tabs, and modify field properties. In addition, you can create predefined column views for screens that contain grids.

The customizations you create can apply to yourself, all users with the same default role, or to all users in the system. You are prompted to specify the customization level when you start and save the customization.

You access design mode by selecting Design Mode in the Tools menu in the screen that you want to customize.

### Settings that Affect Design Mode

Two types of settings affect the operation of design mode:

- Security settings
- System and user settings

## Security Settings

To use design mode, you must be assigned permission to the Customization activity at either the user, role, or general level. If none of these three activities is linked to any of your roles, the Design Mode option is not available in the Tools menu.

For more information on setting up role permissions, see *QAD Security and Controls User Guide*.

The specific customization activities you have access to determine how you can save your screen customizations. For example, if you have access to all three activities, then you can choose to save your changes at the user, role, or general level. If you have access to user level customization only, then you must save your customizations for yourself.

When customizations are saved at the role level, the system uses the default role assigned in Role Permissions Maintain. This is required since each user can have multiple roles active.

When a user accesses a function with multiple customizations, the system applies the most specific customization in the order:

- User customizations
- Customizations for the user's role
- General customizations

If customizations exist for a function on multiple levels, the system does not merge the customizations. It applies the most specific one it finds.

## System and User Settings

Checking for the existence of a screen customization before displaying each screen requires additional system resources and processing time. If you are not using customizations or some users are not using them, this check can be disabled using a setting that can be defined at both the system and user level.

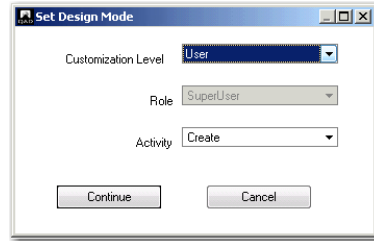
- A system administrator can clear the User Interface Customization setting in Change System Settings (36.24.5.1) to prevent the system from ever looking for existing UI customizations. Users can still use design mode—if design mode activities are linked to their roles, but customized screens are not displayed.
- If User Interface Customization is enabled at the system level, each user can clear the User Interface Customization setting in Change User Settings (36.24.5.2) to disable the check for existing UI customizations for themselves. The user can still use design mode—if design mode activities are linked to their role, but customized screens are not displayed.

**Note** If customization is disabled at the system level, individual users cannot enable it.

## Starting Design Mode

When you select Design Mode, the system prompts you to choose a customization level.

**Fig. 12.1**  
Set Design Mode

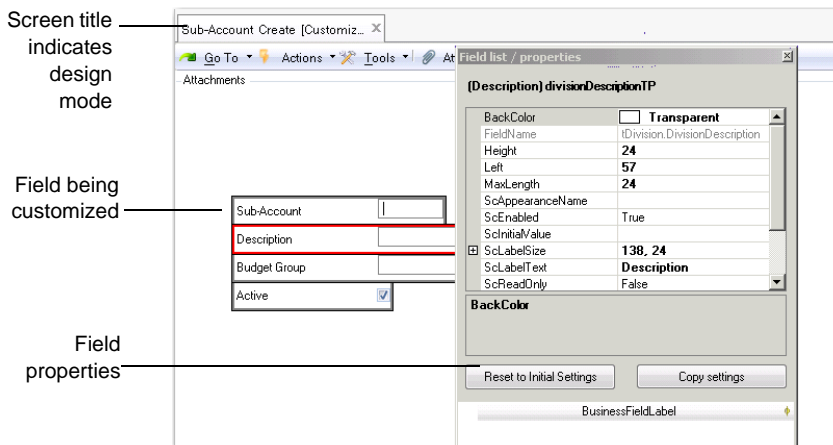


- 1 Choose the level for the customizations:
  - General. The customizations are effective for all users.
  - Role. The customizations are effective for all users who have the selected role as their default role.
  - User. The customizations are effective for you only.

**Note** The choices that display are based on the customization access you have been assigned. See “Security Settings” on page 251.
- 2 If you chose the Role customization level, select the role for which the customizations apply. You can only select from roles that are assigned to your user ID.
- 3 Select the component activity for which the customization applies; for example, Create, Modify, or Delete. This feature lets you, for example, create a different screen layout for viewing or approving transactions than the screen layout for creating or modifying transactions.
- 4 Click Continue to confirm.
 

**Note** When you save a customization for a role other than your own role, a warning message is displayed to inform you that the customization is only visible for users with that role.

**Fig. 12.2**  
Sub-Account Create in Design Mode



In design mode, a gray border is displayed around all fields. When you select a field, its border color changes to red. By selecting the border, you can drag and drop a field or modify its properties.

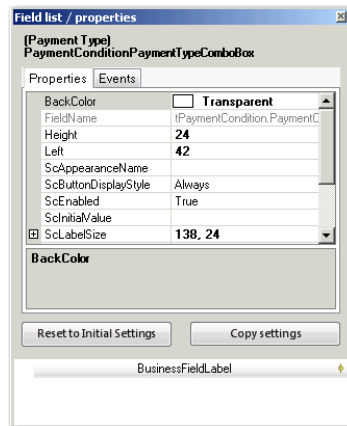
### Field Properties

The Field list/properties window displays the properties that control the appearance of the selected field.

The window contains two tabs, Properties and Events.

#### Properties Tab

**Fig. 12.3**  
Field List/  
Properties, Properties Tab

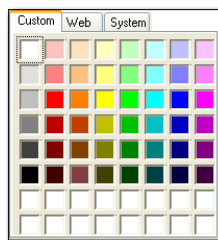


### Field Descriptions

**BackColor.** Specify the color schema for the field. The system applies any color modifications you make to the field border, and not the actual input zone.

Modify the numeric red, green, and blue properties of the field, or select a color from the drop-down list.

**Fig. 12.4**  
Color Palette



**Field Name.** This read-only technical field name is used by data binding information for the control (internal use only).

**Height.** Specify the height of the field (label and input zone) in pixels.

*Left.* Specify the field position in pixels, relative to the left of the screen.

*Max Length.* Specify the maximum length of the field.

*ScAppearanceName.* Specify a user-defined setting from the `Appearances.xml` file to apply to the field. The `Appearances.xml` file is a Cascaded Style Sheet, and contains settings for color, shadowing, and alignment.

To create a new setting, add a new section to the `Appearances.xml` file, as follows:

```
<NewAppearSett>
  <ImageHAlign>Center</ImageHAlign>
  <ImageVAlign>Middle</ImageVAlign>
</NewAppearSett>
```

To apply the new setting to a field, specify the section that contains the settings in the `ScAppearanceName` field; in this example, `NewAppearSett`.

The path to `Appearances.xml` is set in the `QAD.Plugin.Financials.dll.config` file.

*ScChecked.* Specify the initial value for check box fields.

*ScEnabled.* Specify True or False to enable or disable the field.

If you set the property to False, the field continues to display on the screen, but it is no longer accessible in the UI. The field becomes read only, and cannot be tabbed to and its value cannot be copied.

*ScInitialValue.* Specify the initial value of the field. You can use this setting to encourage the use of a particular convention when entering data. For example, you can set the initial value of the Cost Center field to ADMIN for a user who mainly creates transactions for the cost center Admin. The user can overwrite the initial value of the field.

**Note** The initial value cannot be used for the Daybook field because, when you select a daybook from a lookup, the system also retrieves a voucher number. If you used the `ScInitialValue` field to set an initial value for a daybook, the system would not retrieve the corresponding voucher number. However, you can use the Daybook Set functionality to set an initial value for invoice daybooks for both AR and AP invoices.

*ScLabelSize.* Specify the amount of space in pixels (width; height) to allocate to the field label.

*ScLabelText.* Specify the label text for the field.

**Important** The ability to change standard labels is very useful, but can create inconsistencies between screens, and could also create confusion when communicating with the QAD Support helpdesks.

*ScReadOnly.* Select True or False from the drop-down list to indicate whether the field is read-only or editable. When set to True, the field cannot be updated, but can be tabbed to and its contents can be selected and copied.

*Top.* Specify the field position in pixels, relative to the upper left corner of the screen.

*Visible.* Select True from the drop-down list to make the field visible on the UI. Select False to hide the field (including the label).

You can also select a field and drag it into the `BusinessFieldLabel` section to remove it from the UI window. You can also drag fields back from the `BusinessFieldLabel` section to the UI to make them visible again.

**Note** Fields that are hidden from the UI are listed in the BusinessFieldLabel section of the design window.

*Width.* Specify the width of the field (label and input zone) in pixels.

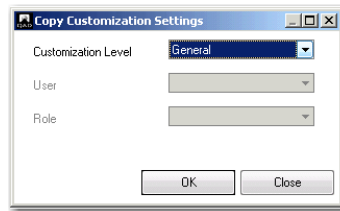
*BusinessFieldLabel.* This section of the design window lists fields that have been hidden on the UI or user-defined fields that have been defined but not yet placed on the UI.

Use the two buttons as follows:

Reset to Initial Settings resets the properties of the field to the initial settings shipped with the application. The system prompts you to confirm the reset operation.

Copy Settings copies the properties of the current customizations to another customization level. You can choose the level and the role or user, if applicable.

**Fig. 12.5**  
Copy Customization Settings



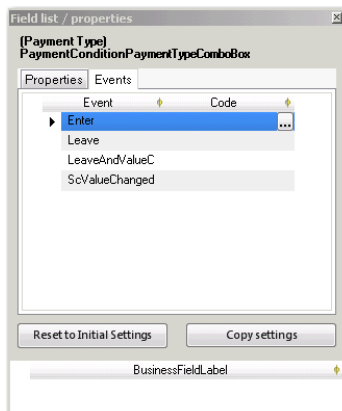
## Event Tabs

The Events tab lets you use the events and properties of UI controls to add basic UI customization code to UI elements. Examples of events include the following:

- Enter, which controls the behavior of a field when it gets focus.
- Leave, which controls the behavior of a field when the field loses focus.

You can select an event from a list of available exposed events for each field or control on the screen for which you are using Design Mode. For any event you select, you can alter the properties of other fields and controls, and specify conditions under which the properties must be altered.

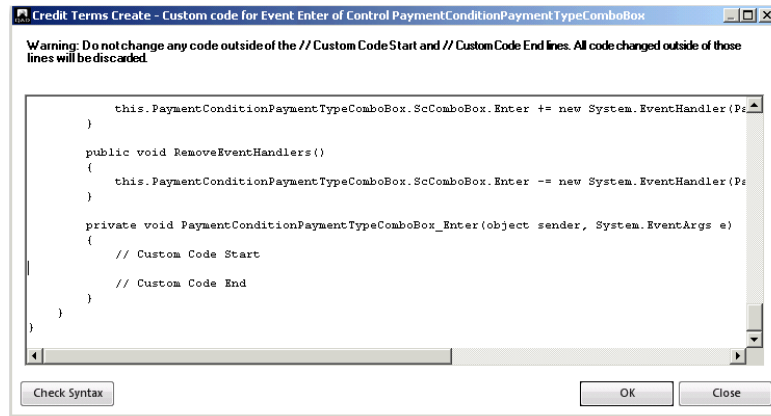
**Fig. 12.6**  
Field/List Properties, Events Tab



In the Events tab, the list of events is sorted alphabetically. When you select an event, a button appears to the right of the event in the Code column. Click this button to open an editor in which you can build a condition and an action (in the case of True or False values).

In the Custom Code for Event editor, you can customize the code using non-intrusive customization. You must add custom code between the `//Custom Code Start` and `//Custom Code End` lines. Any changes you make to the generated code outside of these lines are not saved by the system.

**Fig. 12.7**  
Custom Code for Event Form



In the Custom Code for Event editor, click OK to save and compile your customized C# code. If the compiler finds errors, it displays the errors and the system cancels the saving of the customized code.

Any C# code added using the Events tab becomes part of the UI customization data, and is stored in the `bcontrolproperty` component. You can also export and import code customized in the Custom Code for Event editor using Export UI Customization and Import UI Customization. See “Exporting Customizations” on page 264 and “Importing Customizations” on page 265.

Event information is stored in XML format in the `PropertyValue` field. For events, the `PropertyName` is always formatted as: `EVENT:<eventname>`.

### Communicating with the Business Logic

When adding customized code using the Events tab, you can interact with the backend business logic code using a generic method called `UICustomization`. The `UICustomization` method is defined at business component level, and is available from every adapter in the system.

**Note** All methods defined on the adapter can be used to communicate with the backend business logic code.

In the standard code, the `UICustomization` method does not hold any code, and must be extended using non-intrusive customization on the backend.

The `UICustomization` method has three input parameters: `controlname`, `eventname`, and an input dataset. The method also has one output dataset. These datasets contain identically structured temporary tables. The temporary tables have three fields: `control name`, `property name`, and

value. The input parameter dataset contains control property values passed from the UI. The output dataset must be interpreted by the custom code developer and property values must be set accordingly.

### Example

In this example, the `UICustomization` method has been used to customize the Search field on the Business Relation record. If a user enters the value 1000 in the Search field and then leaves the field, a user-defined field with the `sc_tBusinessRelation_CustomShort1` identifier is enabled on the Business Relation screen. See “User-Defined Fields” on page 265.

```
PROCEDURE BBusinessRelation.UICustomization.after:
  EMPTY TEMP-TABLE tUIOutput.
  IF icControlName = "BusinessRelationSearchTextBox" AND
     icEventName = "Leave"
  THEN DO:
    FIND FIRST tUIInput WHERE
      tUIInput.tcControlName = "BusinessRelationSearchTextBox" AND
      tUIInput.tcPropertyName = "Value" NO-ERROR.
  IF AVAILABLE tUIInput AND tUIInput.tcValue = "1000"
  THEN DO:
    CREATE tUIOutput.
    ASSIGN tUIOutput.tcControlName = "sc_tBusinessRelation_CustomShort1"
           tUIOutput.tcPropertyName = "Enabled"
           tUIOutput.tcValue = "false".
  END.
END.
END PROCEDURE.
```

## Working in Design Mode

You can remove a field from the UI by clicking on the field to activate it and setting the Visible property to False.

The field is then stored in the BusinessFieldLabel pane of the design fame. To return the field to the UI, click on it and drag it from the BusinessFieldLabel pane to the screen.

You can move a field within the UI by dragging it to its new location or by modifying the position properties. You cannot drag a field from one tab to another. To reposition a field to a new tab:

- 1 Set the Visible property to False. The field now displays in the business field area of the Field List window.
- 2 Select the target tab to activate it.
- 3 Drag the field from the storage area to its new location.

## Tab Sequence

The tab sequence of fields is automatically defined using the following rules:

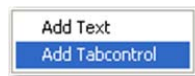
- The reference point is the upper left corner of the field in pixel coordinates.
- The system tabs from left to right and from top to bottom.

Therefore, fields that seem to be on the same row can produce an unexpected tab sequence if the second field on the row is positioned a pixel higher than the first. Refer to the field properties to review and modify the field location.

## Adding Tab Controls

Right-click on a blank area of the current form and select Add TabControl to add one new customizable tab control to the current form.

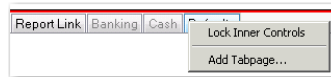
**Fig. 12.8**  
Add Tab Control



## Adding Tabs and Text Fields

You can add new tabs to the current form. Right-click an existing tab header and select Add Tab Page.

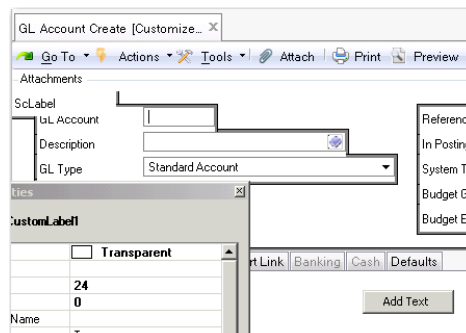
**Fig. 12.9**  
Add Tab Page



The new tab is positioned at the end of the list of tabs and you can customize this tab as you do existing tabs.

To add a new text control to the form, right-click an open area of the screen (not an existing tab header) and select Add Text.

**Fig. 12.10**  
Add Text Control



The new text control is placed at the top left of the form and can be customized and repositioned.

### Adding Grids

When you have created a custom table, you can use drag and drop to add the table to the form as a new grid.

Every business component has three available custom tables. They can be used on the UI, and also in the back-end custom code.

A custom table can be put on a screen as a grid, or columns of the table can be put on a screen as input fields, depending on the relation of the tables to the main table of the business component.

Using custom tables also requires non-intrusive customization of the business logic on the server. This step ensures that the data is validated, saved in the database, and read when the object is called again later.

If you want to add new fields to the UI, it is recommended to use User Defined Fields. These fields are available for each component, and you can add them without customizing the business logic. See “User-Defined Fields” on page 265.

### Repositioning Fields on the User Interface

You can reposition any field by selecting it on the user interface and dragging it to the correct position or by modifying the Left and Top properties of the field in the design window.

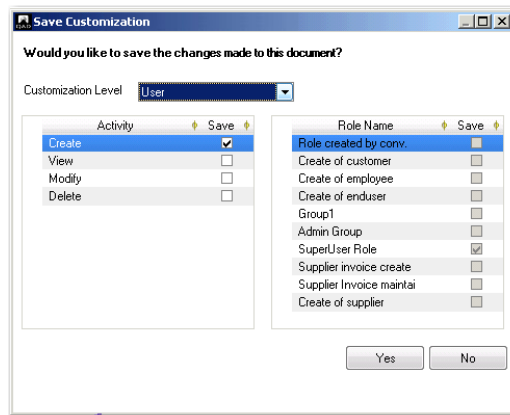
**Fig. 12.11**  
Layout Section of Field Properties

Top	121
Visible	True
Width	330

To apply save customizations to the UI, choose Tools and clear the Design Mode field.

The system prompts you to confirm the changes and lets you select other activities for the business component to which to apply the customizations.

**Fig. 12.12**  
Save Customization



### Field Descriptions

*Customization Level.* Select the level at which the customization applies.

**General.** The customizations are effective for all users.

**Role.** In the Role Name grid, select the roles for which the customizations apply.

**User.** The customizations are effective for you only.

**Activity.** The Save Customization screen lets you apply your customizations to other screens related to the function you customized. This varies depending on the activities defined for each component, but you can typically apply your customizations to the following screen types:

**Create:** Select to apply your layout customizations when the screen is used to create a new record.

**View:** Select to apply your layout customizations when using the screen to view a record.

**Modify:** Select to include your layout customizations when using the screen to modify a record.

**Delete:** Select to include your layout customizations when using the screen to delete a record.

**Role Name.** Select the roles for which the customizations apply. These fields are activated when you select Role in the Customization Level field.

Click Yes to apply the changes to the selected activities. Click No to close the screen without applying the changes.

## Customize Views

Data grids are a common element in component-based functions. You can enable or disable the data fields on the grid lines, or reposition them using generic UI features. The next time you access the function, the grid displays with your modifications. For more information on browses and grids, see *Introduction to QAD Enterprise Applications User Guide*.

**Note** Whether changes to grid settings are preserved from session to session is determined by system and user settings discussed in “Configuring System and User Settings” on page 154.

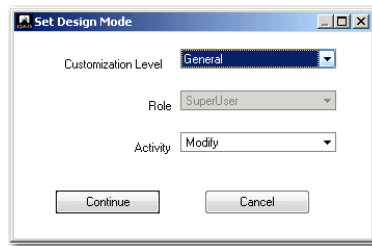
You can also make more extensive customizations to the grid layout using design mode. If a grid contains a large number of data fields, you can predefine column views using design mode.

You can also add custom tables to the form as a new grid.

The example in this section creates two views for the Banking tab of the Supplier screen: an extended view containing all data and a condensed view with key data only.

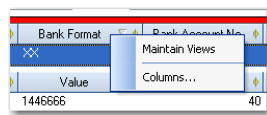
- 1 Open the Supplier Modify screen.
- 2 Click the Banking tab.
- 3 Choose Design Mode from the Tools menu.  
The Set Design Mode screen is displayed.
- 4 Choose the General customization level.

**Fig. 12.13**  
Set Design Mode



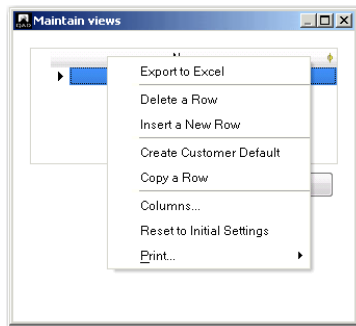
- 5 Click in the grid to activate it for customization.
- 6 Right-click the column headings in the grid and choose Maintain Views.

**Fig. 12.14**  
Right-Click Menu



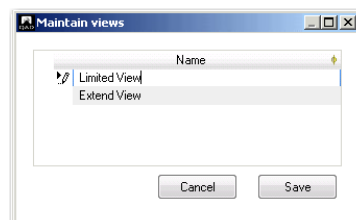
- 7 In the Maintain Views screen, create two views by right-clicking and selecting Insert a New Row.

**Fig. 12.15**  
Maintain Views



- 8 Enter the name of the views in each row.

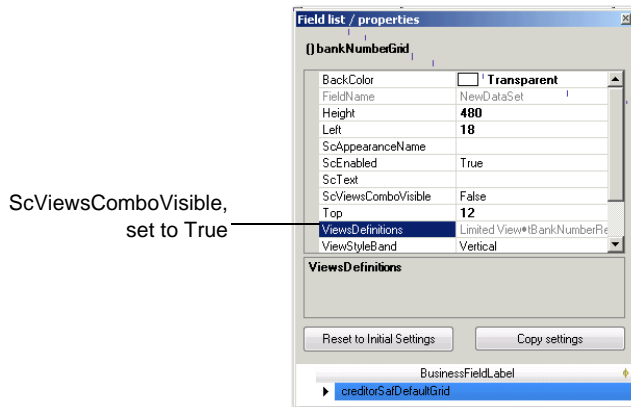
**Fig. 12.16**  
New View



- 9 Click Save to create the view.

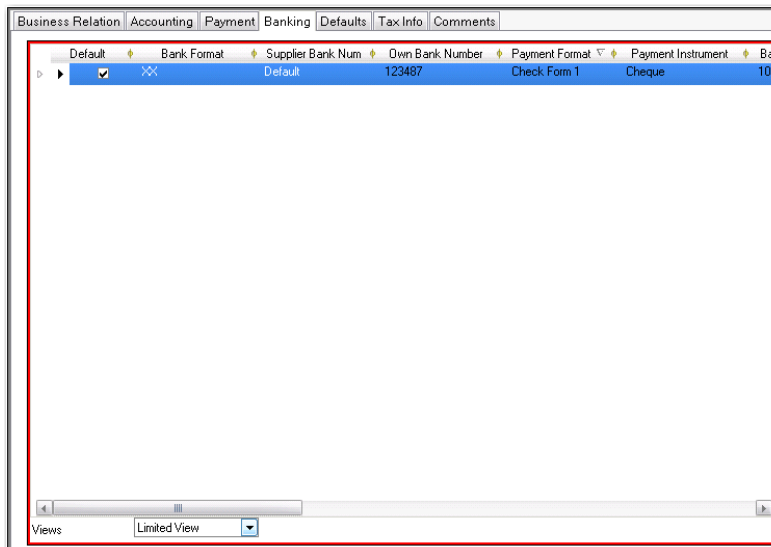
After creating the view, the design window shows an additional property for the grid: ScViewsComboVisible.

**Fig. 12.17**  
ScViewsCombo  
Visible Property Field



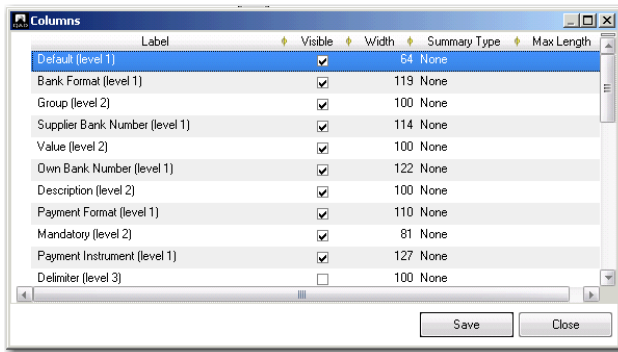
- 10 Set the ScViewsComboVisible property to True.  
An additional drop-down list is displayed in the Banking grid.
- 11 Select the Limited view from the new drop-down list.

**Fig. 12.18**  
Banking Grid, New View



- 12 Right-click in the grid and select Columns.  
The Column screen opens, listing all possible columns for the Banking grid.

**Fig. 12.19**  
Columns



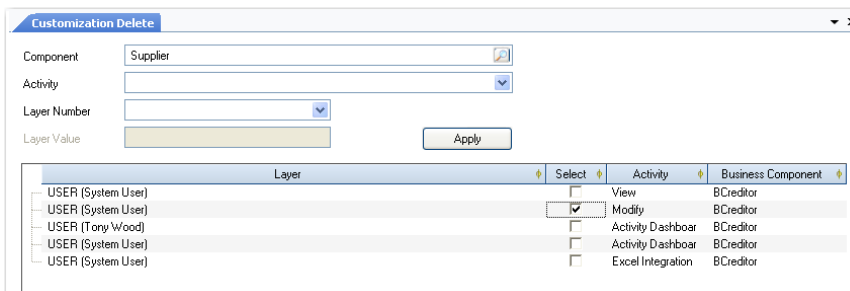
- 13 Deselect the columns that are not required for the condensed view.
- 14 Click OK to confirm.
- 15 Choose Tools and Design Mode to exit design mode.
- 16 In the Save Customization screen, select the save option and click Yes to save.

The customized grid now has the two views available in the combo-box at the end. The columns displayed change as you move from one view to the other.

### Delete Customizations

Use Customization Delete (36.4.19) to delete customizations to the UI. If a customization has been applied to a business component, you can view it in the Customization Delete screen.

**Fig. 12.20**  
Customization Delete



### Field Descriptions

**Component.** Select the business component for which you want to view customizations.

**Select.** Click this check box to indicate that you want to remove the customization.

**Activity.** Select the activity from the drop-down list. This list of activities available depends on the selected component. The default value is All.

**Layer Number.** Select the customization level (user, role, system).

**Layer Value.** If you selected User or Role in Layer Number field, use this lookup to select a specific user or role.

Click Apply to populate the result grid. Select the customizations you want to delete and click Delete to remove them.

## Exporting Customizations

Use Export UI Customization (36.4.26) to export customizations for business component activities including:

- Customizations created in Design Mode, which are exported to `BControlProperty.xml`.
- Saved grid settings, which are exported to `BControlProperty.xml`. To define grid settings, right-click on the header of any grid and choose the Columns option.
- User-defined field definitions, which are exported to `BCustomField.xml`.
- User-defined component definitions, which are exported to `BUDCConfiguration.xml`.
- Stored searches, which are exported to `BStoredSearch.xml`.
- Report variants, which are exported to `BReportVariant.xml`.

**Fig. 12.21**  
Export UI Customization

**Business Component.** Select the business component for which to export customizations.

You can also select the All option to export customizations for all business components.

**Activity.** Specify the business component activity for which to export customizations; for example, Create, Modify, View, Delete, Monitor, Configure, or Maintain.

You can select any activity for the business component you select in the Business Component field. You can also select the All option to export customizations for all activities for the selected business component.

The Activity field is not available if you select the All option in the Business Component field.

**Customization Level.** Select the customization level for which to export customizations for the business component and activity. The options are:

**All.** Select this option to export all customizations for the business component activity.

**Role.** Select this option to export all customizations for the business component activity created by users with a particular role. If you select Role, you must specify the role for which you want to export customizations.

**System.** Select this option to export all customizations for the business component activity that were created using the General option. These customizations are at system level, and are not tied to a particular role or user.

**User.** Select this option to export all customizations for the business component activity that were created by a particular user. If you select User, you must specify the user for which you want to export customizations.

**Role.** Specify the role to export all customizations for the business component activity that were created by users with this role. The Role field becomes available if you select the Role option in the Customization Level field.

**User.** Specify the user to export all customizations for the business component activity created by this user. The User field becomes available if you select the User option in the Customization Level field.

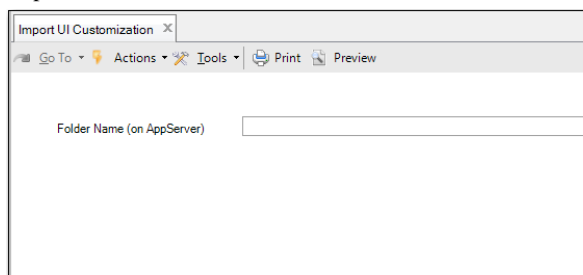
You can also select the All option to export customizations for all users.

**Folder Name (on Appserver).** Specify the full path of the folder to which you want to export the customizations. This field is mandatory.

## Importing Customizations

Use Import UI Customization (36.4.27) to import customizations for business component activities.

**Fig. 12.22**  
Import UI Customization



**Folder Name (on Appserver).** Specify the full path of the folder from which you want to import UI customizations. This field is mandatory.

## User-Defined Fields

User-Defined Fields (UDFs) are predefined fields in the database tables and can be customized to store additional information specific to your business requirements.

Use User Defined Field Create to activate a UDF before you can add it to the UI.

When activated, a UDF can be designated as a filter field in the Search Criteria and can be added to the Search Criteria Result Grid. UDFs are also available for Excel integration, if this functionality is available for the component you have customized.

To include a UDF in the selection criteria for a report or in the report itself, you have to create a non-intrusive customization in order to adapt the selection and the report logic.

UDFs are available for all business components, both on master data, such as business relations and suppliers, and for transactional components, such as customer invoices and supplier invoices.

The following UDFs are available for each category of field:

**Table 12.1**  
UDF Types

Type	Number	Validation
Combo	10	User-defined value list
Date	5	Valid date
Decimal	5	Valid decimal
Integer	5	Valid (signed) integer
Short	10	Free text (maximum 20 characters) or value retrieved through lookup
Long	2	Free text (maximum 255 characters) or value retrieved through lookup
Note	1	Free text (maximum 2000 characters)
QAD Reserved	4	<p>These fields are reserved for use by QAD only.</p> <p>There are four types of QAD reserved field:</p> <ul style="list-style-type: none"> <li>• QADCO1: Free text (maximum 20 characters) or value retrieved through lookup</li> <li>• QADCO2: Free text (maximum 255 characters) or value retrieved through lookup</li> <li>• QADT01: Valid date</li> <li>• QADD01: Valid decimal</li> </ul>

## Create a User-Defined Field

Use the User-Defined Field activities (36.4.12.) to create, modify, view, and delete UDFs.

**Fig. 12.23**  
User-Defined Field Create

The screenshot shows the 'User-Defined Field Create' dialog box. At the top, there are tabs for 'Go To', 'Actions', 'Tools', 'Print', 'Preview', and 'Attach'. Below these are three input fields: 'Business Component' (set to 'Customer'), 'Field Name' (set to 'tDebtor.CustomCombo1'), and 'Description' (set to 'Distribution Channel'). The 'General' tab is selected, and the 'Value List' sub-tab is active. This sub-tab contains several configuration options: 'Side Label' (Distribution Channel), 'Column Label' (Chanel), 'Display Format' (x(20)), 'Display Length' (20), 'Decimal Precision' (0), 'Mandatory' (unchecked), 'Lookup' (Generalized Code), 'Lookup Reference', 'Stored Search', and 'Return Field'.

### Field Descriptions

**Business Component.** Select the business component for which you want to create a UDF. The drop-down list displays the components that have predefined UDFs.

**Field Name.** Select the field that you want to customize. Note that for components that have subcomponent tables, the UDFs of the subcomponent appear in the list also. For example, the Business Relation component has the subcomponents Address, Contact, and Tax Number. When you select a business component, the custom fields available for the business component are displayed in the field name drop-down list.

**Description.** Enter a brief description (maximum 40 characters) of the new UDF.

**Side Label.** Enter the field label that you want to display next to the UDF on the UI. The side label is a translatable string.

**Column Label.** Enter the translatable string to appear in lookup and report column headers.

**Display Format.** This field displays the format of the field.

**Display Length.** This field displays the length in characters of the field's input or display zone. The system displays a default value, depending on the field type, which you can overwrite.

**Decimal Precision.** Specify the number of decimal places allowed in the new UDF. This field is enabled for UDFs of type decimal. The maximum number of decimal places is 10.

**Mandatory.** Select to make it mandatory for users to populate data in the new UDF.

**Lookup.** Select the type of lookup to associate with the new field. The Lookup field is enabled if you select a CustomShort, CustomLong, or CustomCombo type field in the Field Name field in the header.

The possible values are:

- **None:** If you select the None option, the Lookup Reference, Stored Search, and Return Field are disabled.
- **Stored Search:** If you select the Stored Search option, you must use the Lookup Reference and Stored Search fields to identify the stored search.
- **Browse:** If you select the Browse option, the Stored Search field is updated to display the label Browse and the Lookup Reference field becomes read-only. You then use the Browse field to specify the relevant browse definition.
- **Generalized Code:** If you select Generalized Code, the Lookup Reference field lets you select values from the Generalized Codes (code\_mstr) table. If you select the Generalized Code option for a CustomCombo type field, the Value List tab is disabled in the User-Defined Field screen.
- **Other:** If you select Other, you can define a custom query in the Lookup Reference field. The Stored Search and Return Field fields are disabled.

If you are creating a CustomCombo field, you can only select the values None or Generalized Code.

**Lookup Reference.** Click the lookup to select a query from the list of predefined queries. This field lets you specify a standard lookup to associate with the user-defined field. Users can then select a value from the lookup. For example, you can add a UDF to the Customer Invoice object and give it the name Supplier Code, and specify the Supplier lookup as the Lookup Reference. When users create customer invoices, the Supplier Code UDF appears in Customer Invoice Create, and there is a lookup button next to that field listing all supplier codes.

The Lookup Reference field is enabled when you select a field of type CustomShort or CustomLong in the Field Name field.

**Stored Search.** This field is automatically populated when you enter a value in the Lookup Reference field. This value can be FACTORYDEFAULT for system-installed searches or a user-defined name for stored searches.

The lookup attributes are controlled through these defaults, such as columns and display order.

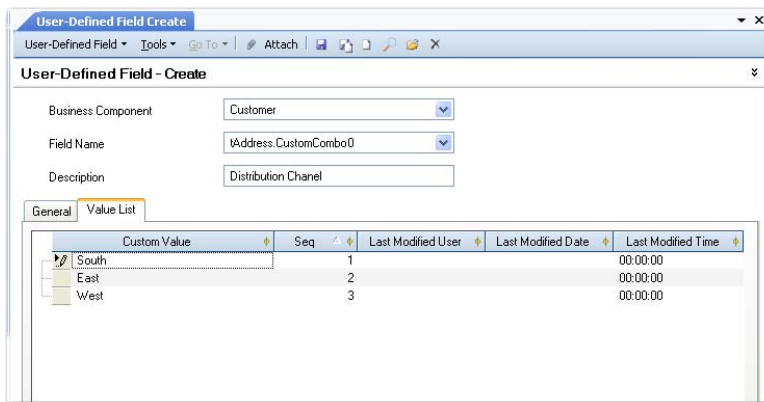
**Return Field.** If a query returns multiple values, select the one with which the UDF value list must be populated.

**Note** To prevent a user from overwriting the value selected from the return list, set the ScReadOnly property of that field to True.

## Value List Tab

Use the Value List tab to define the list of values for a drop-down list UDF. Right-click and choose Insert a New Row to specify a specific value.

**Fig. 12.24**  
User-Defined Field. Value List Tab

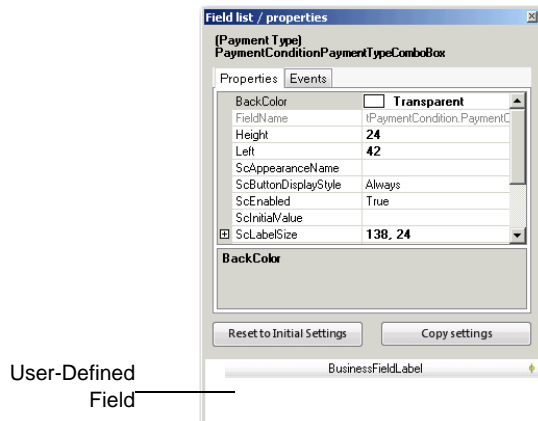


## UDFs and Design Mode

Use design mode to add UDFs to the appropriate screen. When you create a UDF for a component, it is stored in the BusinessFieldLabel pane of the design window.

To add a UDF to a screen, select it and drag it from the Business Field Label section to its new position on the screen.

**Fig. 12.25**  
Field Properties Tab with UDF



## Modifying UDFs

The range of UDF properties you can modify depends on whether the field has been used. A UDF is considered used if it appears on the UI and at least one value has been stored for it in the database.

If the UDF is used, you can still modify the following properties:

- Description
- Side Label
- Column Label
- Value list (for Combo type UDFs only)
- Lookup Reference, Stored Search, Stored Search Return (for Short and Long type UDFs only)

If a UDF is not used, you can modify the following additional properties:

- Mandatory
- Display Length
- Decimal Precision (for decimal type UDFs only)

You can delete a UDF if it has not been used.

## Adding Fields to Financials QRF Reports

Use the following process to add user-defined fields to Financials reports developed using the QAD Reporting Framework (QRF):

- 1 Create the user-defined field. See “Creating the New Field” on page 270.
- 2 Link the new field to the QRF report, and specify the report resultset field that will display data for the new user-defined field. See “Linking the UDF to the Report” on page 270.
- 3 Use Report Resource Designer (36.4.21.30) to add the resultset field to the report. See “Adding the Resultset Field to a Report” on page 272.

## Creating the New Field

To add a user-defined field to a QRF report, determine the component for which you want to add the field, and add the field to a component that is part of the report's dataset. For example, to customize the Supplier Check Print report, you can add fields to the Supplier component or to the Supplier Invoice component.

Define the field using the User-Defined Field function. See “Create a User-Defined Field” on page 266 for detailed information.

**Fig. 12.26**  
User-Defined Field Modify

The screenshot shows the 'User-Defined Field Modify' dialog box. It has a title bar with 'User-Defined Field Modify' and a close button. Below the title bar is a menu bar with 'Go To', 'Actions', 'Tools', 'Print', 'Preview', and 'Attach'. The main area contains several fields: 'Business Component' (dropdown menu with 'Supplier' selected), 'Field Name' (text box with 'tCreditor.CustomDate0'), and 'Description' (text box with 'Certification Date'). Below these is a tabbed interface with 'General' and 'Value List' tabs. The 'General' tab is active and contains: 'Side Label' (text box with 'Certification Date'), 'Column Label' (text box with 'Certification Date'), 'Display Format' (text box with '99/99/9999'), 'Display Length' (text box with '0'), and 'Decimal Precision' (text box with '0').

**Important** After you define the field, add the field to the UI using design mode so that the field can become usable and receive data that can be displayed on the report. See “UDFs and Design Mode” on page 268

## Linking the UDF to the Report

Use User-Defined Fields on Report Maintain (36.25.92) to associate user-defined fields with reports developed using QRF. When you open User-Defined Fields on Report Maintain, a browse displays a list of all Financials reports developed using QRF.

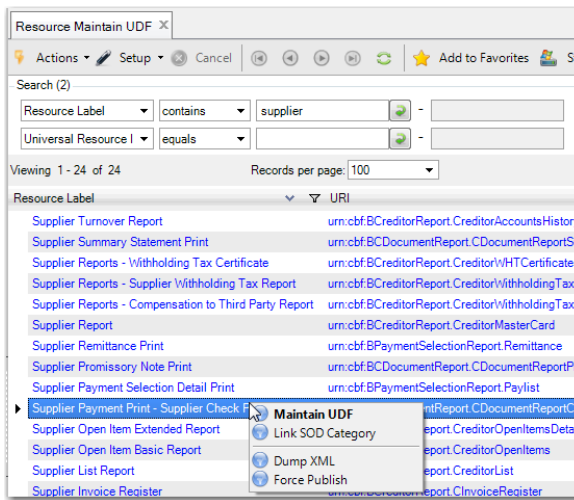
**Fig. 12.27**  
User-Defined Fields on Report Maintain Browse

The screenshot shows the 'Resource Maintain UDF' dialog box. It has a title bar with 'Resource Maintain UDF' and a close button. Below the title bar is a menu bar with 'Actions', 'Setup', 'Cancel', and 'Add to Favorites'. There is also a 'Stored Searches' dropdown. The main area contains a search section with two search criteria: 'Resource Label equals' and 'Universal Resource I equals'. Below the search area is a table listing various reports and their URIs. The table has two columns: 'Resource Label' and 'URI'. The table is sorted by 'Resource Label' and shows 137 records. The first record is '1099-MISC Report (US) - 1099-Misc Paper Declaration' with URI 'urn:cbf.BBox1099Report.M1099MiscPaperDeclaration'. The second record is 'Account Balance of Totals' with URI 'urn:cbf.BGLReport.AccBalanceTOT'. The third record is 'Account Transaction Journal' with URI 'urn:cbf.BGLReport.AccTransJournal'. The fourth record is 'AP versus Control GL Validation' with URI 'urn:cbf.BCclosingPostingsReport.CreditorControlGLBalance'. The fifth record is 'AR versus Control GL Validation' with URI 'urn:cbf.BCclosingPostingsReport.DebtorControlGLBalance'. The sixth record is 'Balance Sheet Report' with URI 'urn:cbf.BGLReport.BalanceSheetReport'. The seventh record is 'Bank Import Report - Imported Bank File Report' with URI 'urn:cbf.BBankImportReport.ImportedBankFileReport'. The eighth record is 'Budget Detail' with URI 'urn:cbf.BBudgetReporting.BudgetDetail'. The ninth record is 'Budget Overview' with URI 'urn:cbf.BBudgetReporting.BudgetOverview'. The tenth record is 'Cash and Bank GL Report' with URI 'urn:qad-report:c1.QAD\_BGLReport\_CBGLReport'. The eleventh record is 'Cash and Bank Payment Journal' with URI 'urn:cbf.BGLReport.CBPaymentJournal'. The twelfth record is 'Cash and Bank Receipt Journal' with URI 'urn:cbf.BGLReport.CBReceiptJournal'. The thirteenth record is 'Columnar Ledger Report' with URI 'urn:cbf.BGLReport.ColumnarLedgers'. The fourteenth record is 'Con Report' with URI 'urn:cbf.BConCheckReport.ConCheckReport'. The fifteenth record is 'Cost Center Trans Detail Report' with URI 'urn:cbf.BAnalyticalReport.CostCentreTransDet'. The sixteenth record is 'Cost Center Trans Summary Report' with URI 'urn:cbf.BAnalyticalReport.CostCentreTransSumm'. The seventeenth record is 'Customer Account Activity' with URI 'urn:cbf.BDebtorReport.DebtorAccountMovements'.

Resource Label	URI
1099-MISC Report (US) - 1099-Misc Paper Declaration	urn:cbf.BBox1099Report.M1099MiscPaperDeclaration
Account Balance of Totals	urn:cbf.BGLReport.AccBalanceTOT
Account Transaction Journal	urn:cbf.BGLReport.AccTransJournal
AP versus Control GL Validation	urn:cbf.BCclosingPostingsReport.CreditorControlGLBalance
AR versus Control GL Validation	urn:cbf.BCclosingPostingsReport.DebtorControlGLBalance
Balance Sheet Report	urn:cbf.BGLReport.BalanceSheetReport
Bank Import Report - Imported Bank File Report	urn:cbf.BBankImportReport.ImportedBankFileReport
Budget Detail	urn:cbf.BBudgetReporting.BudgetDetail
Budget Overview	urn:cbf.BBudgetReporting.BudgetOverview
Cash and Bank GL Report	urn:qad-report:c1.QAD_BGLReport_CBGLReport
Cash and Bank Payment Journal	urn:cbf.BGLReport.CBPaymentJournal
Cash and Bank Receipt Journal	urn:cbf.BGLReport.CBReceiptJournal
Columnar Ledger Report	urn:cbf.BGLReport.ColumnarLedgers
Con Report	urn:cbf.BConCheckReport.ConCheckReport
Cost Center Trans Detail Report	urn:cbf.BAnalyticalReport.CostCentreTransDet
Cost Center Trans Summary Report	urn:cbf.BAnalyticalReport.CostCentreTransSumm
Customer Account Activity	urn:cbf.BDebtorReport.DebtorAccountMovements

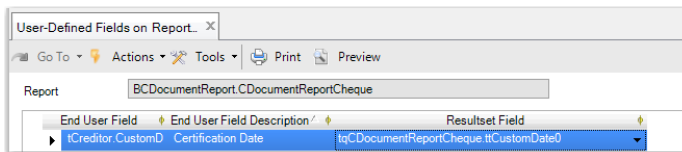
In the browse, select the report to which you want to add the user-defined field. Then, right-click and select Maintain UDF.

**Fig. 12.28**  
User-Defined Fields on Report Maintain Browse, Context Menu



When User-Defined Fields on Report Maintain opens for the report you selected, the grid lists the user-defined fields that have been created for components in the report’s dataset. Locate the field you want to add to the report, and, in the Resultset Field column, specify the report field in which you want to display data. Save your changes.

**Fig. 12.29**  
User-Defined Fields on Report Maintain



*Report.* Displays the name of the data source for the report.

*End User Field.* Displays the database field name for the user-defined fields that have been created for components in the report’s dataset.

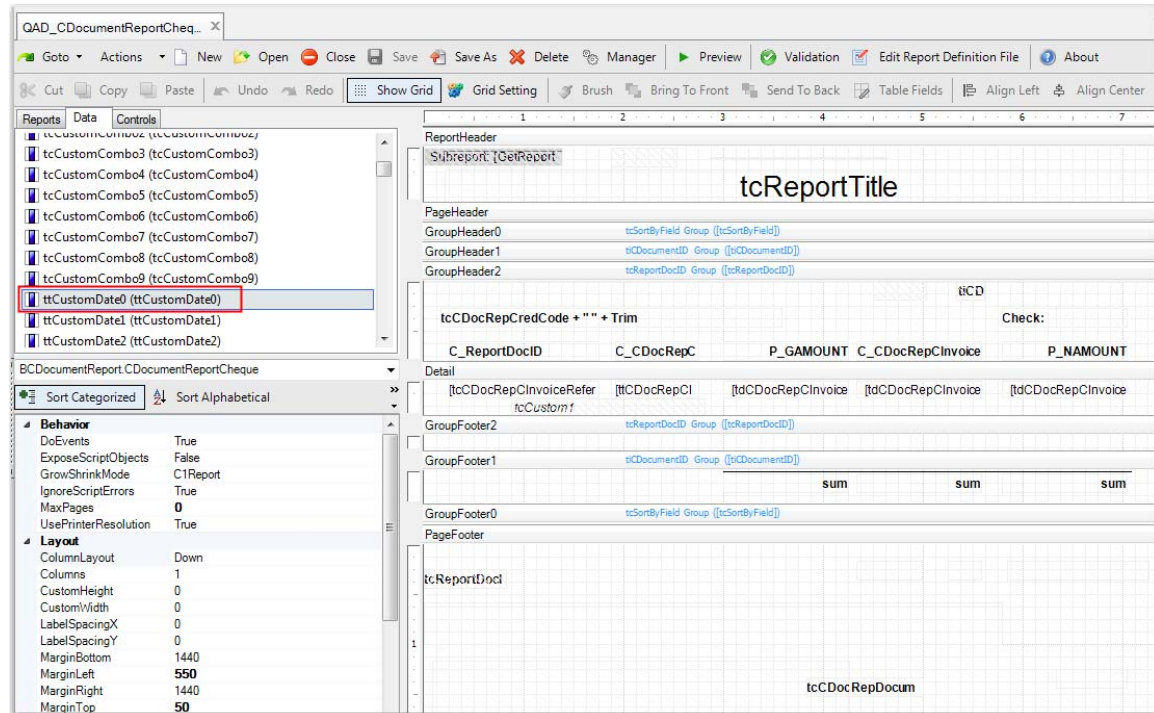
*End User Field Description.* Displays a description of the user-defined field, as defined in User-Defined Field Create.

*Resultset Field.* Select the report field in which you want to display data for the user-defined field. Select a resultset field of the same type as the user-defined field. For example, if the user-defined field is a date field, select a resultset date type field.

## Adding the Resultset Field to a Report

To add the user-defined field to a QRF report, open the report in Report Resource Designer. Add the report resultset column that you linked to the user-defined field to the report design and then save your changes.

**Fig. 12.30**  
Report Resource Designer, Supplier Check Print Report



For more information on QRF reports and on Report Resource Designer, see [QAD Reporting Framework User Guide](#).

## User-Defined Components

The User-Defined Components option lets you define your own business component for use in the application.

You implement this option by customizing a generic back-end business component, and deploying generic business classes that are designed specifically for customization. You then use non-intrusive customization techniques to implement data loading and saving for the new component.

These techniques are described in Chapter 10, “Customizing Business Logic,” on page 219.

You can create the following types of user-defined components:

- **Create/Modify/View/Delete.** This component type is used to create, modify, view and delete records in the usual way. This is the standard program type, and only one instance of the component is displayed on the form at one time. Examples of this program type include Country Create and Cost Center Create.

- **Maintain.** This component type is used to maintain existing records. Maintenance programs display multiple instances of the component in a maintenance grid on the form, and are most useful for components for which there are not a great number of records. An example of a maintenance program is Payment Format Maintenance, in which all the records are displayed in the form grid, and you can create, modify, and delete records in the same form.

You can create components of one type or the other, but you cannot assign both Create/Modify/View/Delete activities and the Maintain activity to the same component.

The following sections describe the code elements required to implement a new business component, and also a sample implementation of the procedure.

## Elements of User-Defined Component Implementation

The following component and classes are designed for use with user-defined components:

- `BCustom`, the generic customizable business component
- `Customform.cs`, the generic form used for all user-defined components
- `CustomAdapter.cs`, the generic adapter class
- `CustomProcessObject.cs`, the generic process object

### BCustom

This is the generic component used for customization.

The `BCustom` object dataset contains three custom tables only:

- `tCustomTable0`
- `tCustomTable1`
- `tCustomTable2`

You must devise the data loading and saving mechanisms by writing custom code for the `DataNew` and `DataLoad` methods using non-intrusive customization techniques.

### Activities

`BCustom` has the following related activities:

- Create
- Modify
- View
- Delete
- Maintain

The Create, Modify, View and Delete activities handle single instances of the component. The Maintain activity handles multiple instances, and requires a different `DataLoad` implementation.

You can implement either the Create, Modify, View, and Delete activities or the Maintain activity for the component, but you cannot implement both.

The implemented activity is named and displayed in the menu in the usual way, using the syntax:

```
urn:cbf:BCustom[<user-defined component name>].<activity>
```

For example, the Create activity for a newly defined Province component is displayed as follows:

```
Example: urn:cbf:BCustom[Province].Create
```

#### vcCustomComponent Variable

The `vcCustomComponent` variable is defined for `BCustom` and is set at the instantiation of the component. This variable contains the name of the custom component, which is taken from the URN specified for the menu item. This variable must be set before any other method on the component can be run.

The system loads customizations for standard components by checking the `/customcode` folder for customized `.p` files. In the same way, the system also checks the `/customcode` folder for `bcustom[<vcCustomComponent>].p` files for customizations of the custom component you have created.

#### Select Query

You can add a select query to the custom component for use with Modify, View, and Delete activities. You implement the query using non-intrusive customization techniques. See page 278 for details on coding a select query.

#### CustomForm.cs

`CustomForm.cs` is inherited from `ScForm` and is used for all user-defined components. It does not contain any controls (except for the standard buttons on every form). You customize this form using non-intrusive customization, and use the form in combination with the adapter `CustomAdapter.cs` and process object `CustomProcessObject.cs`.

The constructor of this form has an extra input parameter for the user-defined component name that is set on the process object. This parameter takes its value from the component name defined between the square brackets in the menu URN (for example, Province from `urn:cbf:BCustom[Province]`). The parameter is passed to the `GetProcessObject` method on the custom adapter, which then passes it to the business layer when instantiating the custom business component.

#### CustomAdapter.cs

`CustomAdapter.cs` is the generic custom adapter class, and is inherited from `ScAdapter.cs`. This custom adapter communicates with `BCustom` on the back end.

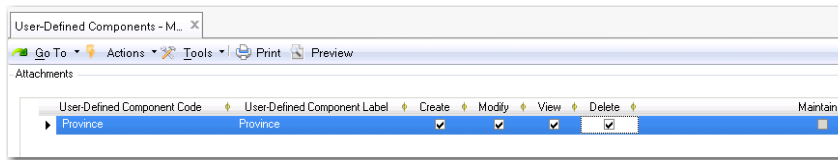
#### CustomProcessObject.cs

This is the generic process object class, and is inherited from `ScProcessObject`. `CustomProcessObject.cs` holds data for `CustomForm`. It contains the property `ComponentName`, which holds the name of the custom component in use.

### User-Defined Components Maintain

Use the User-Defined Components Maintain (36.4.12.1.1) option to maintain user-defined components.

**Fig. 12.31**  
User-Defined Components Maintain



The grid displays existing user-defined components.

When you have coded a new component, insert a new row in the grid and complete the fields.

*User-Defined Component Code.* Enter the code that identifies the component. This must match the code you use in the URN for the menu item. For example, when the URN for a newly defined component is `urn:cbf:BCustom[Province]`, the code you enter in the field must match the code between the square brackets (Province).

*User-Defined Component Label.* Enter a label for the component which identifies it in the system.

*Create/Modify/View/Delete.* Select the activities you have defined for this component. When you select one or a combination of these activities, the Maintain activity is unavailable.

*Maintain.* Select this field when you have created a maintenance component only. When you select this field, the other activities are unavailable.

## Example of User-Defined Component

In this example, you create a Province program (similar to the Country or State programs), which you can use to create, modify, view, and delete provinces. The example includes a description of how to create a lookup for the existing Country component, which you select in order to identify the country to which the province belongs. You use the non-intrusive customization method to deploy the customized code in the baseline.

### Non-Intrusive Customization

When coding a user-defined component, you use non-intrusive customization techniques. QAD application component code is based on a standard code template. You can customize any of the standard activities (for example, Create, Modify, or Delete) by writing code that is activated with a publish-subscribe mechanism, in which a customized event is published before or after the component code. A code template (`BCComponent.p`) is provided for each business component. The template code is commented, and to hook the event code into the component process, you uncomment the event and add the necessary component code. This process is called *non-intrusive* customization, because the customized code is added before or after the standard code, but does not intrude on the standard code itself. This technique is described in Chapter 10, “Customizing Business Logic,” on page 219.

### Creating a New Component

The procedure for creating a new component can be divided into three parts:

- Preparing the component data

- Creating the customized code
- Deploying the new component in the application

### Preparing the Component Data

Use the following steps to prepare the data for the new component:

#### 1 Create a new database.

When you create a new component, it is recommended that you create a new database in which to store the data. This avoids data loss or conflict when you upgrade your application. You should ensure that the new database starts and stops at the same time as your application database.

#### 2 Update the `server.xml` file for the appserver to include an entry for your new database. This ensures that it is automatically connected when you run the application:

```
<database>
  <name>C:\Work\Foundation\mycustomizations\db\mycustom</name>
  <parameters></parameters>
</database>
```

#### 3 Create the necessary tables and fields (and indexes) to store the data in.

For this example, create the following `Province` table:

Table: Province

FIELD SUMMARY

Flags: <c>ase sensitive, <i>index component, <m>andatory, <v>iew component

Order	Field Name	Data Type	Flags
5	Province_ID	inte	i
10	ProvinceCode	char	i
20	ProvinceDescription	char	
30	CountryCode	char	

Field Name	Format
Province_ID	->, >>>, >>9
ProvinceCode	x(20)
ProvinceDescription	x(40)
CountryCode	x(20)

Field Name	Initial
------------	---------

```

-----
Province_ID          0
ProvinceCode
ProvinceDescription
CountryCode

Field Name          Label          Column Label
-----
Province_ID        ?              ?
ProvinceCode       ?              ?
ProvinceDescription ?              ?
CountryCode        ?              ?
    
```

INDEX SUMMARY

Flags: <p>primary, <u>nique, <w>ord, <a>bbreviated, <i>nactive, + asc, - desc

Flags	Index Name	Cnt	Field Name
u	Code	1	+ ProvinceCode
pu	prim	1	+ Province_ID

The Province\_ID column is not strictly necessary, but some constructions in the framework depend on having an ID column.

### Creating the Customized Code

- 1 Review the non-intrusive customization techniques described in Chapter 10, “Customizing Business Logic,” on page 219.
- 2 Copy `bcustom.p` from the template directory to your work directory and rename it `bcustom[province].p`.

The code name between the square brackets needs to match the name of your user-defined component, which will be created later in the procedure.

The custom component has three tables you can use to contain your data: `tCustomTable0`, `tCustomTable1`, and `tCustomTable2`. You must use at least one of these tables. In this example, only one table is required:

- 3 Uncomment the `BCustom.DefineCustomRelations.before` method and add the following code:

```

create tCustomRelation.

assign tCustomRelation.tcParentTable      = ""
      tCustomRelation.tcChildTable       = "tCustomTable0"
      tCustomRelation.tcChildTableDescription = "Province"
      tCustomRelation.tlIsOneToOne       = true.
    
```

Because this is the main table, you do not complete the `tcParentTable` field.

When creating a component that uses the Create/Modify/Delete/View activities, you require a Select query to run in the browse for the Modify, Delete, and View activities:

**4** Uncomment the `BCustom.ApiSelectCustom.after` method and adding the following code:

```
define variable vhBuffer as handle no-undo.
define variable vhProvince as handle no-undo.

if not t_Parameter.ilCountOnly
then do:
  create temp-table vhProvince.
  vhProvince:create-like(buffer Province:handle).
  vhProvince:add-new-field("tc_rowid", "character").
  vhProvince:add-new-field("tiCustom[Province]_ID", "integer").
  vhProvince:temp-table-prepare("tqApiSelectCustom").
  vhBuffer = vhProvince:default-buffer-handle.
end.

for each Province no-lock:
  if t_Parameter.ilCountOnly
  then assign t_Parameter.oiCount = t_Parameter.oiCount + 1.
  else do:
    vhBuffer:buffer-create().
    vhBuffer:buffer-copy(buffer Province:handle).
    vhBuffer:buffer-field("tiCustom[Province]_ID"):buffer-value = Province.Province_ID.
    vhBuffer:buffer-field("tc_rowid"):buffer-value = string(rowid(Province)).
  end.
end.

if not t_Parameter.ilCountOnly
then t_Parameter.ozApiSelectCustom:set-buffers(vhBuffer).

assign t_Parameter.olEndOfQuery = true.
```

This creates a dynamic temp-table similar to the database table. Two fields are added: `tc_rowid` (required to make the framework work correctly) and `tiCustom[Province]_ID` (required to make the browse work correctly). Again, the code name between the square brackets needs to match the name of your custom component.

You also need to ensure that you have business field definitions for the fields used in the query:

**5** Uncomment `BCustom.GetBusinessFields.after` and add the following code:

```
if t_Parameter.icReference = "ApiSelectCustom"
then do:
  create tBusinessFields.
  assign tBusinessFields.tcSideLabel = "Province Code"
  tBusinessFields.tcColumnLabel = "Province"
  tBusinessFields.tcControlType = "TextBox":U
  tBusinessFields.tcFcFieldType = "F":U
  tBusinessFields.tcDataType = "c":U
  tBusinessFields.tcDisplayFormat = "x(20)"
  tBusinessFields.tcLookupFilterField = ""
  tBusinessFields.tcLookupQuery = ""
  tBusinessFields.tcLookupReturnField = ""
  tBusinessFields.tcRelatedObject = ""
  tBusinessFields.tcFilterOperators = "":U
  tBusinessFields.tcFcFieldName = "tCustomTable0.tcCustomShort0".

  create tBusinessFields.
  assign tBusinessFields.tcSideLabel = "Province Description"
  tBusinessFields.tcColumnLabel = "Description"
  tBusinessFields.tcControlType = "TextBox":U
  tBusinessFields.tcFcFieldType = "F":U
  tBusinessFields.tcDataType = "c":U
  tBusinessFields.tcDisplayFormat = "x(40)"
  tBusinessFields.tcLookupFilterField = ""
```

```

tBusinessFields.tcLookupQuery      = ""
tBusinessFields.tcLookupReturnField = ""
tBusinessFields.tcRelatedObject    = ""
tBusinessFields.tcFilterOperators  = "":U
tBusinessFields.tcFcFieldName      = "tCustomTable0.tcCustomLong0".

create tBusinessFields.
assign tBusinessFields.tcSideLabel      = "Country Code"
tBusinessFields.tcColumnLabel          = "Country"
tBusinessFields.tcControlType          = "TextBox"
tBusinessFields.tcFcFieldType          = "F":U
tBusinessFields.tcDataType             = "c":U
tBusinessFields.tcDisplayFormat        = "x(3)"
tBusinessFields.tcLookupFilterField    = "tCountry.CountryCode"
tBusinessFields.tcLookupQuery          = "BCountrySAO.SelectCountry"
tBusinessFields.tcLookupReturnField    = "tqSelectCountry.tcCountryCode"
tBusinessFields.tcRelatedObject        = ""
tBusinessFields.tcFilterOperators      = ""
tBusinessFields.tcFcFieldName          = "tCustomTable0.tcCustomShort1".

create tBusinessFields.
assign tBusinessFields.tcSideLabel      = "Province Code"
tBusinessFields.tcColumnLabel          = "Province"
tBusinessFields.tcControlType          = "TextBox"
tBusinessFields.tcFcFieldName          = "tqApiSelectCustom.ProvinceCode"
tBusinessFields.tcFcFieldType          = "B"
tBusinessFields.tiSequence             = 0
tBusinessFields.tcDataType             = "c"
tBusinessFields.tcDisplayFormat        = "x(20)".

create tBusinessFields.
assign tBusinessFields.tcSideLabel      = "Province Description"
tBusinessFields.tcColumnLabel          = "Description"
tBusinessFields.tcControlType          = "TextBox"
tBusinessFields.tcFcFieldName          = "tqApiSelectCustom.ProvinceDescription"
tBusinessFields.tcFcFieldType          = "B"
tBusinessFields.tiSequence             = 1
tBusinessFields.tcDataType             = "c"
tBusinessFields.tcDisplayFormat        = "x(40)".

create tBusinessFields.
assign tBusinessFields.tcSideLabel      = "Country Code"
tBusinessFields.tcColumnLabel          = "Country"
tBusinessFields.tcControlType          = "TextBox"
tBusinessFields.tcFcFieldName          = "tqApiSelectCustom.CountryCode"
tBusinessFields.tcFcFieldType          = "B"
tBusinessFields.tiSequence             = 2
tBusinessFields.tcDataType             = "c"
tBusinessFields.tcDisplayFormat        = "x(3)".
end.

```

Notice that some business fields have `tcFcFieldType` set to F. These fields appear in the filter of the browse. It is important to ensure that the `tcFcFieldName` field matches the name defined for the fields in the custom table you are using. Note also that the lookup fields are completed for the Country Code filter field. Here we reuse the existing lookup for Countries so the user can select a country on which to filter.

You can also notice that some business fields have `tcFcFieldType` set to B. These fields appear in the results grid of the browse. Use the `tiSequence` field to define the initial order of the columns in the grid. You can use any value for the `tcFcFieldName` field, providing it begins with `tqApiSelectCustom` and does not contain more than one “.”.

You now create code to load data from the new database into the custom table:

## 6 Uncomment the `BCustom.DataLoad.after` method and add the following code:

```
define variable viA as integer no-undo.
```

```

if t_Parameter.icPKeys <> "" and
  t_Parameter.icPKeys <> ?
then do viA = num-entries(t_Parameter.icPKeys, chr(4)) to 1 by -1:
  find Province where
    Province.Province_ID = int(entry(viA, t_Parameter.icPKeys, chr(4)))
  no-lock no-error.

if not available Province
then do:
  run SetMessage(
    input "Province with ID $1 not found.",
    input entry(viA, t_Parameter.icPKeys, chr(4)),
    input "",
    input "",
    input "E",
    input 3,
    input "",
    input "PROVINCE-6",
    input "",
    input "",
    input "",
    output t_Parameter.oiReturnStatus).

  assign t_Parameter.oiReturnStatus = -1.
  return.
end.

create tCustomTable0.
create t_iCustomTable0.

assign tCustomTable0.tiCustomInteger0 = Province.Province_ID
tCustomTable0.tcCustomShort0 = Province.ProvinceCode
tCustomTable0.tcCustomLong0 = Province.ProvinceDescription
tCustomTable0.tcCustomShort1 = Province.CountryCode
tCustomTable0.tc_Rowid = string(rowid(Province)).

buffer-copy tCustomTable0 to t_iCustomTable0.
end.

if t_Parameter.icRowids <> "" and
  t_Parameter.icRowids <> ?
then do viA = num-entries(t_Parameter.icRowids) to 1 by -1:
  find Province where
    rowid(Province) = to-rowid (entry(viA, t_Parameter.icRowids))
  no-lock no-error.

if not available Province
then do:
  run SetMessage(
    input "Province with RowID $1 not found.",
    input entry(viA, t_Parameter.icRowids),
    input "",
    input "",
    input "E",
    input 3,
    input "",
    input "PROVINCE-7",
    input "",
    input "",
    input "",
    output t_Parameter.oiReturnStatus).

  assign t_Parameter.oiReturnStatus = -1.
  return.
end.

create tCustomTable0.
create t_iCustomTable0.

assign tCustomTable0.tiCustomInteger0 = Province.Province_ID
tCustomTable0.tcCustomShort0 = Province.ProvinceCode

```

```

tCustomTable0.tcCustomLong0 = Province.ProvinceDescription
tCustomTable0.tcCustomShort1 = Province.CountryCode
tCustomTable0.tc_Rowid      = string(rowid(Province)).

    buffer-copy tCustomTable0 to t_iCustomTable0.
end.

```

Note that the fields `tiCustomInteger0`, `tcCustomShort0`, `tcCustomLong0`, and `tcCustomShort1` are used to store new data. You later define those fields as user-defined fields for the Province component, in the same way as you define user-defined fields for any component.

You now write the code required to create a new Province.

**7** Uncomment the `BCustom.DataNew.after` method and add the following code:

```

define variable vhPersistence as handle no-undo.

run AddDetailLine(
    "CustomTable0",
    "",
    output t_Parameter.oiReturnStatus).

run StartPersistence(output vhPersistence, output t_Parameter.oiReturnStatus).

if t_Parameter.oiReturnStatus < 0
then return.

assign tCustomTable0.tiCustomInteger0 = dynamic-function("GetNextValue" in vhPersistence,
"ObjectNumber").

```

The standard mechanism is used to assign a new value to the `Province_ID` (`tiCustomInteger0`) field.

You now write the code required to validate the data entered by the user:

**8** Uncomment the `BCustom.ValidateComponent.after` method and add the following code:

```

for each t_sCustomTable0 where
    t_sCustomTable0.tc_Status = "N" or
    t_sCustomTable0.tc_Status = "C":
if t_sCustomTable0.tc_Status = "C"
then do:
    find t_iCustomTable0 where
        t_iCustomTable0.tc_Rowid = t_sCustomTable0.tc_Rowid
        no-error.

    if not available t_iCustomTable0
    then do:
        run SetMessage(
            input "t_iCustomTable0 with rowid " + t_sCustomTable0.tc_Rowid + " not
            found.",
            input "",
            input "",
            input "",
            input "E",
            input 3,
            input t_sCustomTable0.tc_Rowid,
            input "PROVINCE-1",
            input "",
            input "",
            input "",
            output t_Parameter.oiReturnStatus).

        assign t_Parameter.oiReturnStatus = -3.
        return.
end.

```

```

if t_sCustomTable0.tcCustomShort0 <> t_iCustomTable0.tcCustomShort0
then do:
  run SetMessage(
    input "It is not allowed to change the Province Code of an existing
    Province.",
    input "",
    input "tCustomTable0.tcCustomShort0",
    input t_sCustomTable0.tcCustomShort0,
    input "E",
    input 3,
    input t_sCustomTable0.tc_Rowid,
    input "PROVINCE-2",
    input "",
    input "",
    input "",
    output t_Parameter.oiReturnStatus).

    assign t_Parameter.oiReturnStatus = -1.
  end.
end.
else
if can-find(first Province where
  Province.ProvinceCode = t_sCustomTable0.tcCustomShort0)
then do:
  run SetMessage(
    input "Province already exists.",
    input "",
    input "tCustomTable0.tcCustomShort0",
    input t_sCustomTable0.tcCustomShort0,
    input "E",
    input 3,
    input t_sCustomTable0.tc_Rowid,
    input "PROVINCE-3",
    input "",
    input "",
    input "",
    output t_Parameter.oiReturnStatus).

    assign t_Parameter.oiReturnStatus = -1.
  end.

if t_sCustomTable0.tcCustomShort1 <> "" and
(t_sCustomTable0.tc_Status = "N" or
t_sCustomTable0.tc_Status = "C" and
t_sCustomTable0.tcCustomShort1 <> t_iCustomTable0.tcCustomShort1)
then do:
  if not can-find(first Country where Country.CountryCode =
  t_sCustomTable0.tcCustomShort1)
  then do:
    run SetMessage(
      input "Invalid country code.",
      input "",
      input "tCustomTable0.tcCustomShort1",
      input t_sCustomTable0.tcCustomShort1,
      input "E",
      input 3,
      input t_sCustomTable0.tc_Rowid,
      input "PROVINCE-4",
      input "",
      input "",
      input "",
      output t_Parameter.oiReturnStatus).

      assign t_Parameter.oiReturnStatus = -1.
    end.
  end.
end.
end.

```

You finally require code to store the new and modified data in the database.

**9** Uncomment the `BCustom.DataSave.after` method and add the following code:

```

for each tCustomTable0 where
    tCustomTable0.tc_Status <> "":
if tCustomTable0.tc_Status = "C" or
    tCustomTable0.tc_Status = "D"
then do:
    find Province where
        Province.Province_ID = tCustomTable0.tiCustomInteger0
        exclusive-lock no-error.

    if not available Province
    then do:
        run SetMessage(
            input "Province $1 not found.",
            input tCustomTable0.tcCustomShort0,
            input "",
            input "",
            input "E",
            input 3,
            input "",
            input "PROVINCE-5",
            input "",
            input "",
            input "",
            output t_Parameter.oiReturnStatus).

            assign t_Parameter.oiReturnStatus = -1.
            return.
        end.

    if tCustomTable0.tc_Status = "D"
    then do:
        delete Province.
        next.
    end.
end.
else do:
    create Province.
    assign Province.Province_ID = tCustomTable0.tiCustomInteger0.
end.

assign Province.ProvinceCode = tCustomTable0.tcCustomShort0
    Province.ProvinceDescription = tCustomTable0.tcCustomLong0
    Province.CountryCode = tCustomTable0.tcCustomShort1.
end.

```

**Important** In order to compile this code, the application database and your custom database (if you created one) must be connected.

**10** Compile the custom code by executing the `build.p`.

Make sure the `build.p` contains the following line:

```

compile value("bcustom[province].p") save into
C:\Work\Foundation\mycustomizations\customcode.

```

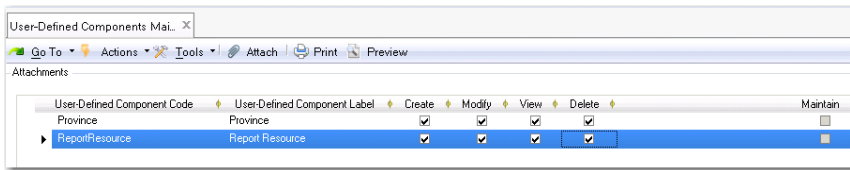
The folder you save the code into must be the folder where your custom compiled code is located.

**11** Trim the Financials appserver to make sure the customization controller picks up the changed file.

## Deploying the New Component in the Application.

- 1 Run the application.
- 2 Run the User-Defined Components Maintain menu option and do the following:
  - a Insert a new row in the grid.
  - b Complete the necessary fields. Make sure that the User-Defined Component Code matches the code name used in the URN (see “Elements of User-Defined Component Implementation” on page 273).
  - c Click on the Save button to save the definition of your user-defined component.

**Fig. 12.32**  
User-Defined Components Maintain

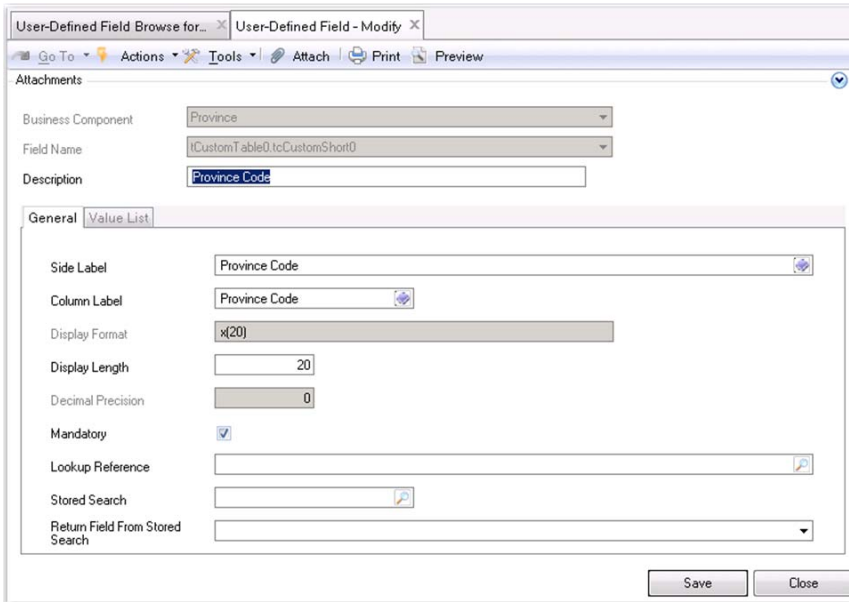


- 3 Use User-Defined Field Create to create a user-defined field for each field you used in your custom code.

In this example, you need a field for `tCustomTable0.tcCustomShort0`, `tCustomTable0.tcCustomLong0` and `tCustomTable0.tcCustomShort1`.

**Note** You do not define a field for `tCustomTable.tiCustomInteger0`. This field in the code contains the `Province_ID`, which should not be visible in the interface.

**Fig. 12.33**  
User-Defined Field, Province



**Fig. 12.34**  
User-Defined Field, Province Description

The screenshot shows the 'User-Defined Field - Modify' dialog box. The 'Attachments' section is expanded, showing the following fields:

- Business Component: Province
- Field Name: tCustomTable0.tcCustomLong0
- Description: Province Description

The 'General' tab is selected, showing the following configuration:

- Side Label: Description
- Column Label: Description
- Display Format: x(255)
- Display Length: 255
- Decimal Precision: 0
- Mandatory:
- Lookup Reference: (empty)
- Stored Search: (empty)
- Return Field From Stored Search: (empty)

Buttons for 'Save' and 'Close' are visible at the bottom right.

**Fig. 12.35**  
User-Defined Field, Province Country

The screenshot shows the 'User-Defined Field - Modify' dialog box. The 'Attachments' section is expanded, showing the following fields:

- Business Component: Province
- Field Name: tCustomTable0.tcCustomShort1
- Description: Province Country Code

The 'General' tab is selected, showing the following configuration:

- Side Label: Country Code
- Column Label: Country Code
- Display Format: x(20)
- Display Length: 20
- Decimal Precision: 0
- Mandatory:
- Lookup Reference: /BCountry.SelectCountry
- Stored Search: FACTORYDEFAULT
- Return Field From Stored Search: tCountry.CountryCode

Buttons for 'Save' and 'Close' are visible at the bottom right.

Because the existing country lookup is linked to the country code field, the user can select a country instead of typing an existing country code.

- 4 Create menu items for the activities using Menu System Maintenance.

**Fig. 12.36**  
Menu System Maintenance

Menu System Maintenance

Go To Actions Copy Print Preview

Language ID: us                      english (U.S.)  
Menu: 36.1.3.5                      Province Maintenance

Selection: 1

Label: Province Create  
Name:   
Exec Procedure: urn:cbf:BCustom[Province].Create

Delete Back Next

Adding new record

Again, the code name between the square brackets in the Exec Procedure field must match the code of your custom component exactly.

Do the same for the Modify, View and Delete activities.

- 5 In Role Permissions Maintain, double-click on each role that requires permissions for the Province activities and link those activities to the role.

**Fig. 12.37**  
Role Permissions Maintain

Role Browse for Permissions Role - Permissions

Go To Actions Tools Attach Print Preview

Attachments

Role Name: SuperUser  
Role Description: SuperUser Role

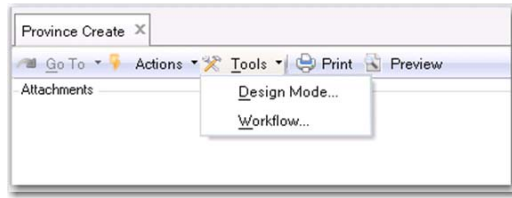
Secured items on menu

- Customer Management
- Supply Chain
- Manufacturing
- Financials
- Master Data
- System Administration
  - System Administration (36)
    - Corporate Structure Setup Menu (36.1)
      - Structure Setup Menu (36.1.1)
      - Geographical Setup Menu (36.1.3)
        - Country Maintenance (36.1.3.1)
        - State Maintenance (36.1.3.2)
        - County Maintenance (36.1.3.3)
        - BLVL Group Maintenance (36.1.3.4)
        - Province Maintenance (36.1.3.5)
          - Province Create (36.1.3.5.1) [Entity]
          - Province Modify (36.1.3.5.2) [Entity]
          - Province View (36.1.3.5.3) [Entity]
          - Province Delete (36.1.3.5.4) [Entity]
      - Address Setup Menu (36.1.4)
      - Employee Maintenance (36.1.7)
      - Credit Terms Maintenance (36.1.10)
      - Invoice Status Code Maintenance (36.1.11)
    - Domain Constants Menu (36.2)
    - System Security Menu (36.3)
    - System Interface Menu (36.4)
    - External Interface Menu (36.5)

- 6 Log out of the application and back in again to ensure the new menu items are deployed.

- 7 Run Province Create.

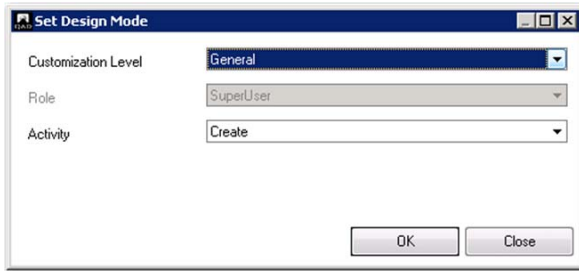
**Fig. 12.38**  
Province Create



An empty form is displayed. You must still design the layout of the form.

- 8 Click on Tools/Design Mode.

**Fig. 12.39**  
Design Mode, Customization Level

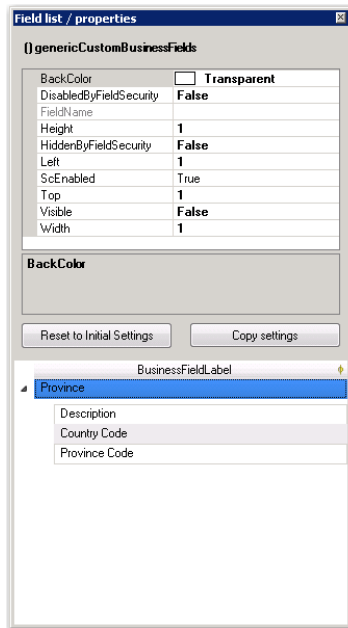


- 9 Select General as the Customization Level.

This ensures that your design can be used by all users that have rights to execute Province Create.

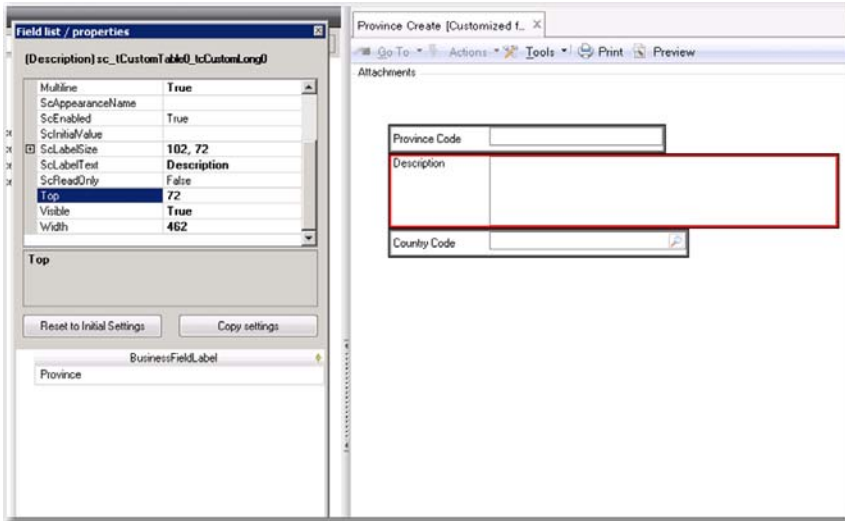
The Field List/Properties dialog is displayed. Collapse or expand the fields of the Province table by clicking the icon.

**Fig. 12.40**  
Field List/Properties Dialog



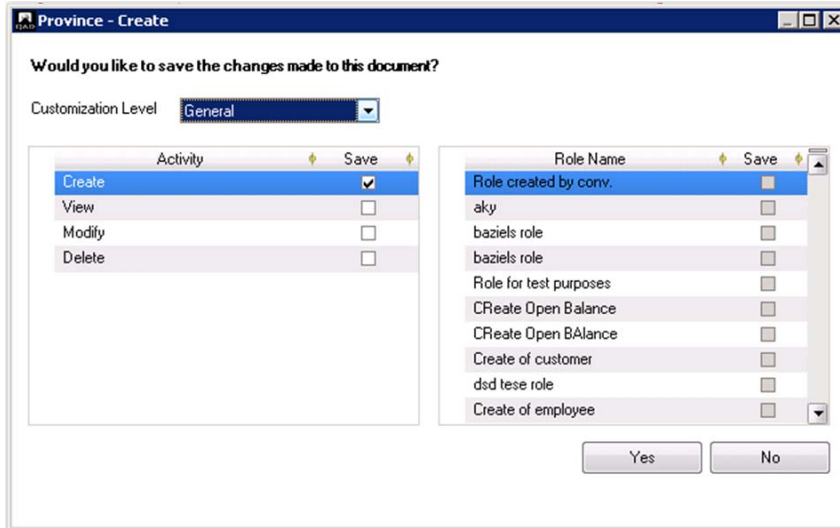
You can choose to drag and drop the entire Province table to your form. However, this results in a grid, which is more normally used in maintenance components. Because you are using the Create/Modify/View/Delete activities, you drag and drop each field individually to your form.

**Fig. 12.41**  
Customized Province Form



When you close the design form, you are prompted to save your changes.

**Fig. 12.42**  
Province Form Save Changes



You normally use the same form layout for the View, Modify, and Delete activities.

- 10 Select the Save field for these activities and click to save the new form design.
- 11 Test all activities for the Province program in the application.

## Financial Text Translation

You can maintain label and message translations in the financial programs by using Financial Translation Maintenance (36.24.10).

This program enables you to:

- Search for financial translations using different filters.
- Edit current translations while keeping a record of the original.

The program also marks a record as updated when it is modified and records the last modified user ID and date.

**Note** When you run System Synchronize (36.24.3.2), it does not overwrite records that you have changed. Also, although Financial Translation Maintenance does not maintain report text directly, the report text does refer to the financial translations. Therefore, if you run System Synchronize with report text, the report text copies the values in the financial translations.

**Fig. 12.43**  
Financial Translation Maintenance

Selected	Text Number	Current Text	Original Text	Language	Updated
<input checked="" type="checkbox"/>	000000200	GL Account	GL Account	us	<input checked="" type="checkbox"/>
<input type="checkbox"/>	000002315	GL Account	GL Account	us	<input checked="" type="checkbox"/>
<input type="checkbox"/>	0000064373	GL Account	GL Account	us	<input checked="" type="checkbox"/>
<input type="checkbox"/>	000001010	GL Account	GL Account	us	<input type="checkbox"/>
<input type="checkbox"/>	000001011	GL Account	GL Account	us	<input type="checkbox"/>
<input type="checkbox"/>	000002275	GL Account	GL Account	us	<input type="checkbox"/>
<input type="checkbox"/>	000014940	GL Account	GL Account	us	<input type="checkbox"/>
<input type="checkbox"/>	0000055549	GL Account	GL Account	us	<input type="checkbox"/>
<input type="checkbox"/>	0000057140	GL Account	GL Account	us	<input type="checkbox"/>
<input type="checkbox"/>	0537732759	GL Account	GL Account	us	<input type="checkbox"/>

There are two ways to update current strings:

- In the grid, in the Current Text column, type the new text and click Save. This approach is generally best when you want to edit one string.
- In the New Text For Selected Rows field, type the new text and select the row or rows to display the new text, and click Apply. To keep your changes, click Save. This approach is best when you want to update multiple strings with the same text.

The fields in the program have the following function:

**Language.** Specify the language code for the text you want to search for. This field is mandatory.

**Text Number.** Enter the string number of the text you want to search for. This field is useful because there are many translation records with the same meaning but with unique string numbers. If you do not enter a text number, you must enter either the current text or the original string.

**Current Text.** Enter the current translated text as it appears in the interface. If you do not enter the current text, you must enter either the text number or the original string. This field accepts wild cards.

**Original Text.** Enter the original string as supplied by QAD. The original text is stored in the system permanently with its initial values. If you do not enter the original string, you must enter either the text number or the current text. This field accepts wild cards.

When you click Search, the grid populates with the matching text strings. Most of the fields in the grid are read only.

However, you can select the Selected field to indicate a string to apply changes to or to be saved. To change the text of a current string, you can also edit the text in the Current Text column directly. When you edit the current text, the row is automatically selected. If you clear a selected row, any changes are discarded and the row reverts to the previous text.

**Note** Some strings contain placeholders such as '&1', '&2', which are replaced by the relevant program. You cannot change these placeholders, and if you try, an error message is displayed. However, you can edit other parts of the string.

The original text is still saved in the system, and is displayed in the Original Text column, as displayed in Figure 12.44. The other columns are Language, Label, Last Updated Date, Last Updated Time, and Last Updated User. Three additional columns—Component Code, Component Category, and Project—are hidden by default.

**Fig. 12.44**  
Financial Translation - Original Text

Selected	Text Number	Current Text	Original Text	Language
<input checked="" type="checkbox"/>	000000200	GL Account	GL Account	us
<input type="checkbox"/>	0000002315	GL Acc	GL Account	us
<input type="checkbox"/>	0000064373	GL Acc	GL Account	us
<input type="checkbox"/>	0000001010	GL Account	GL Account	us
<input type="checkbox"/>	0000001011	GL Account	GL Account	us

**New Text For Selected Rows.** You can change multiple rows simultaneously by using this field. Select the rows that are to contain the updated text and then type the text in this field. When you click Apply, the Current Text field in the grid is updated.

Make sure you click Save so that your changes take effect. You can view your changes when the next system trim takes place. The frequency of a system trim depends on organization policy. If you perform a second search before saving your changes, the changes are lost and the grid populates with the new data.

# Installing Electronic Bank File Formats

This chapter describes the procedure for installing a custom bank file format for use in electronic banking.

***Introduction to Electronic Banking Format Installation 292***

Explains how electronic banking functions are used by Enterprise Financials.

***Setting up EDI eCommerce to Use Imported Bank Formats 292***

Explains how to set up EDI eCommerce to use imported bank formats.

***Using Bank File Format Import to Install the Format 295***

Explains how to use Bank File Format Import to install formats.

***Default Directory Settings 297***

Discusses default directory settings.

## Introduction to Electronic Banking Format Installation

To use the electronic banking functions in Enterprise Financials, you must complete the setup steps for bank accounts and payment formats. Each electronic transaction requires a payment format appropriate for the type of payment, which is then linked to the dedicated bank account for the customer or supplier. For more information on setting up electronic banking, see [QAD Financials User Guide](#).

For many electronic payment files, you must import predefined formats that are customized for the bank's individual requirements. The imported formats are then displayed in the list of available payment formats and can then be linked to the bank accounts used for the payments.

To configure and install these predefined formats, you use a number of EDI eCommerce functions to create a definition for the specific bank file format. You then use the Bank File Format Import (31.23) program to import the file into the Financials application. You can link the dedicated file format to the customer or supplier bank account.

## Setting up EDI eCommerce to Use Imported Bank Formats

Before importing the bank file formats, you must define the following information in EDI eCommerce:

- The file names and number range sequences for the banking files that will be produced using this format.
- The default data input and output eCommerce directory locations.
- The number counters for both the banking files and for the eCommerce application itself.
- A cross-reference between the user's QAD domain and the eCommerce processing domain.

Use the following procedure to complete this setup.

## Create Number Range Sequences in EC Number Range Maintenance (35.21.1).

**Fig. 13.1**  
EC Number Range Maintenance

EC Number Range Maintenance

Go To Actions Copy Print Preview

Sequence Master

Sequence ID: ecFin1  
Description: Bank Driver Counter 1  
Target Dataset:  
Internal:   
Allow Discarding:  Effective Date: 1/20/2010  
Allow Voiding:  Expiration Date:

Segment List

Nbr	Type	Settings	Control
1	FIX:ED	edi	

Integer Segment Editor

New Seg Nbr:  Minimum Value:  Initial Value:   
Maximum Value:  Reset Value:

Delete Back Next

- 1 Create five number range sequences; for example, using the sequence IDs ecFin1, ecFin2, ecFin3, ecFin4, ecFin5.
- 2 For each sequence, ensure that the Target Dataset fields Internal, Allow Discarding, and Allow Voiding are selected.
- 3 Each sequence must contain two segments: a Fixed segment in which you specify the Fixed part of the format filename, and an Integer segment in which you specify the numeric part of the format filename. For example, when you specify 'edi' as Fixed, and a number range of 0 to 999999999, you ensure that the bank files you produce using this format will be named 'edi00000001.\*'

The file extensions for these files are defined in EC Subsystem Definition Maintenance (35.13.1).

The five sequences you create are later used to specify counters in eCommerce Control. See "Assign Number Sequences to EDI Documents" on page 294.

**Note** You complete these steps for the first installation of bank format files only—you do not need to complete the process the next time you install an additional bank file format or when installing an update of an existing bank format.

## View the EDI Control File in eCommerce Control (35.13.24)

**Fig. 13.2**  
eCommerce Control, Default Directories

The screenshot shows the 'eCommerce Control' application window. The title bar includes 'Go To', 'Actions', 'Copy', 'Print', and 'Preview' menus. The main content area is titled 'eCommerce Control' and contains the following fields and options:

- Default Subsystem: EDI-Windows
- Import Data To Application:
  - Input Directory: //qad01/EDI/ecg/inbound/
  - Archive Directory: //qad01/EDI/ecg/archive/
  - Error Directory: //qad01/EDI/ecg/err/
- Export Data From Application:
  - Input Directory: //qad01/EDI/ecg/scan
  - Archive Directory: //qad01/EDI/ecg/archive/
  - Error Directory: //qad01/EDI/ecg/err/
- Function Directory: //qad01/EDI/ecg/function/
- Process Log Directory: //qad01/EDI/ecg/log
- Print Fail/Pass/Both:  B  Both
- Print Details:
- Report Output: eComRpt

At the bottom right, there are 'Back' and 'Next' buttons.

The EDI Control File displays the default server directories for data import and export, and for the EDI functions and process log.

You must ensure that the application users have read/write permissions for these folders, and that the server path name is displayed in full for each directory.

The Functions path name must also be included in the Appserver Propath to ensure that EDI functions execute correctly.

## Assign Number Sequences to EDI Documents

**Fig. 13.3**  
eCommerce Control, Number Sequences

The screenshot shows the 'eCommerce Control' application window. The title bar includes 'Go To', 'Actions', 'Copy', 'Print', and 'Preview' menus. The main content area is titled 'eCommerce Transaction Control' and contains the following fields and options:

- Suppress Warnings:
- Stop On Error:
- Suppress Session Report:
- Send Email On Error Only:
- Email Address:
- Source Code Page:
- Inbound Exchange Counter: eFin1
- Outbound Exchange Counter: eFin2
- Inbound Application Counter: eFin3
- Outbound Application Counter: eFin4
- Error Counter: eFin5

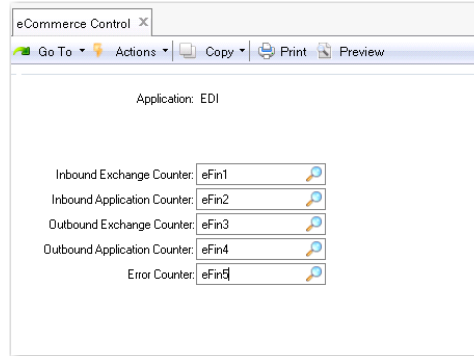
4 Click Next on the eCommerce Control screen to display the Counter fields.

5 Select the number sequences created previously for each of the five fields.

## Assign Number Sequences to the EDI application

6 Click Next to display the Application frame.

**Fig. 13.4**  
eCommerce Control, Applications Frame



7 Select the EDI application in the Application lookup (the default application).

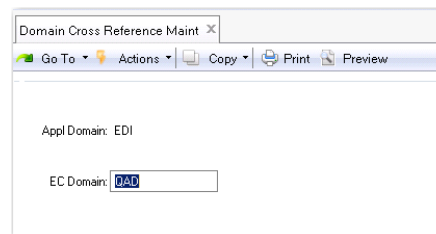
8 Select the number sequences created previously for each of the five fields.

**Note** For more information on the eCommerce Control fields, see *QAD EDI eCommerce User Guide*.

## Create a Domain Cross-Reference

9 Use Domain Cross-reference Maintain (35.11.1) to create a cross-reference between the EDI eCommerce user's log-in domain and the domain used in eCommerce processing.

**Fig. 13.5**  
Domain Cross-Reference Maintain



By defining cross-references, you can let users log in to their usual domain, but still process EDI eCommerce imports and exports in a different domain.

A QAD eCommerce processing domain is provided by default.

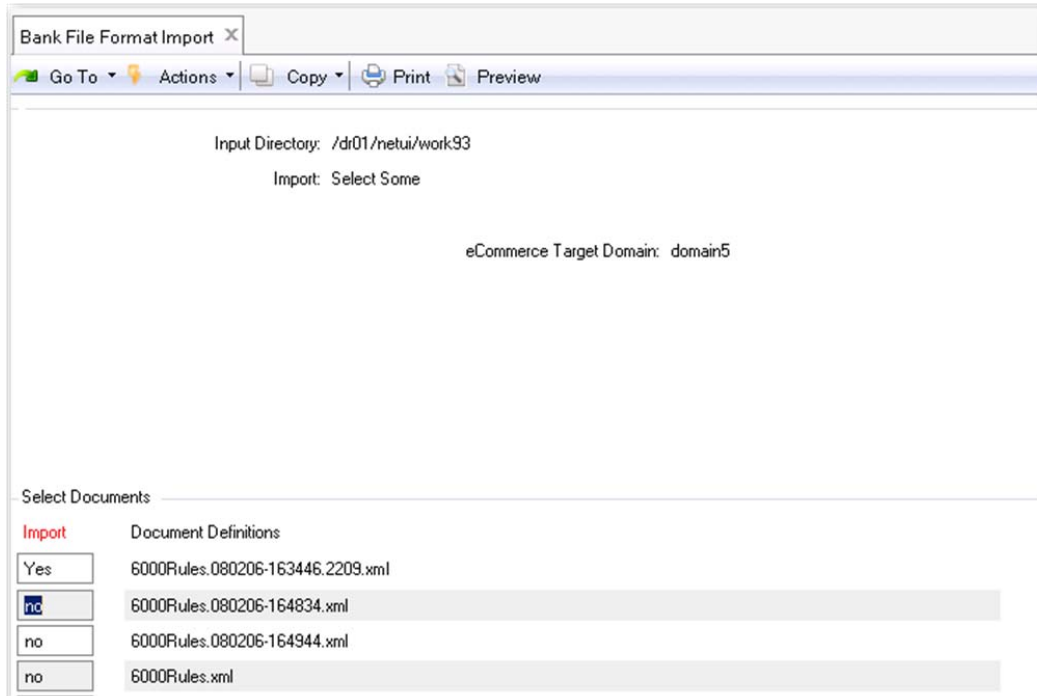
## Using Bank File Format Import to Install the Format

Each imported format file is specific to an individual bank and contains the payment information and attributes required for that bank.

The format definition files are usually delivered by the bank in zipped XML format. You unzip the files to a server directory and then load the files into the system using Bank File Format Import (31.23).

This program creates mapping records that let the system process incoming files correctly, using the configuration you defined in EDI eCommerce. It also generates the outbound files that meet the requirements of the receiving bank. Additionally, it updates a set of financial setup tables that define the payment format for each bank.

**Fig. 13.6**  
Bank File Format Import



- 1 Specify the Input Directory in which the unzipped XML files are stored.
- 2 Select Some, All, or a single bank XML file.

The eCommerce domain is a read-only field indicating the domain that the trading partner information will be loaded into. If the definition needs to be loaded into a different eCommerce domain, you must exit this screen, change to a different eCommerce domain and re-open this menu option. An eCommerce domain is associated with one or many QAD domains. During export processing, the QAD domain is used to determine the eCommerce domain in which to process under.

**Note** For more information on domains, see *QAD EDI eCommerce User Guide*. Bank File Format Import is described in detail in *QAD Financials User Guide*.

Some .NET UI installations do not display a scroll bar on this screen for the list of XML files available for import. If a great many XML files are listed, you can change the Bank File Format Import program to display in Terminal mode, by selecting the menu Properties and changing the Open With value to Terminal. Close the program and start it again. When in Terminal mode, you can use the keyboard to scroll through the list of available XML files.

- 3 Review the library import log for any errors or warnings.

A typical warning is that the function directory does not exist or that a particular user-defined function will not compile. The log file is named `library-import-<today's date>-<nnnnnn>.log`. The value `nnnnnn` is incremented each time an import occurs during the day, which prevents the overwriting of an existing log file. This log file can be found in the work directory of Progress (appserver) on the server.

**Note** For outbound definitions, you should verify the Transmission Group Destination directory and File Name Counter. This can be accessed through Transmission Group Maintenance (35.13.13). A Transmission Group defines the destination of the bank file being exported and what counter definition is used to generate the file name. The outbound destination directory is where the bank drivers create the bank files, and where you retrieve the files before sending them to the bank for processing.

## Default Directory Settings

When loading a bank driver, the default settings for the various directories and number ranges will be retrieved from the eCommerce Control setup as described in this chapter. If the control record does not exist, the system uses the directories and number ranges specified in the `eCommerceDefaultSettings.xml` and creates a eCommerce Control setup on-the-fly.

If both the eCommerce Control record and the XML file are not available, the system creates an eCommerce Control record on-the-fly, and sets all directories set to the value “.”, which points to the work directory for Progress (appserver) on the server.

The following is an example of the `eCommerceDefaultSettings.xml` file layout:

```
<?xml version="1.0" encoding="utf-8"?>
<eCommerceSettings>
  <ControlFileSetting>
    <Domain></Domain>
    <ImportInputDirectory>/dr01/.../ec/in</ImportInputDirectory>
    <ImportArchiveDirectory>/dr01/.../ec/arch</ImportArchiveDirectory>
    <ImportErrorDirectory>/dr01/.../ec/err</ImportErrorDirectory>
    <ExportInputDirectory>/dr01/.../ec/in</ExportInputDirectory>
    <ExportArchiveDirectory>/dr01/.../ec/arch</ExportArchiveDirectory>
    <ExportErrorDirectory>/dr01/.../ec/err</ExportErrorDirectory>
    <FunctionDirectory>dr01/.../ec/func</FunctionDirectory>
    <InboundExchangeCounter>eComNrm</InboundExchangeCounter>
    <OutboundExchangeCounter>eComNrm</OutboundExchangeCounter>
    <InboundApplicationCounter>eComNrm</InboundApplicationCounter>
    <OutboundApplicationCounter>eComNrm</OutboundApplicationCounter>
    <ErrorCounter>eComNrm</ErrorCounter>
  </ControlFileSetting>
</eCommerceSettings>
```



# Product Information Resources

QAD offers a number of online resources to help you get more information about using QAD products.

[QAD Forums \(community.qad.com\)](http://community.qad.com)

Ask questions and share information with other members of the user community, including QAD experts.

[QAD Knowledgebase \(knowledgebase.qad.com\)\\*](http://knowledgebase.qad.com)

Search for answers, tips, or solutions related to any QAD product or topic.

[QAD Document Library \(http://documentlibrary.qad.com\)](http://documentlibrary.qad.com)

Get browser-based access to user guides, release notes, training guides, and so on; use powerful search features to find the document you want, then read online, or download and print PDF.

[QAD Learning Center \(learning.qad.com\)\\*](http://learning.qad.com)

Visit QAD's one-stop destination for all courses and training materials.

\*Log-in required



# Index

## Numerics

2.13.13 175  
7.15.14 36  
11.21.22.24 198  
17.17 22  
36.2.1 17  
36.2.13 19  
36.2.17 22  
36.2.21.1 24  
36.2.21.5 32  
36.2.21.13 33  
36.2.21.23 33  
36.2.22 34  
36.3.21.23.18 54  
36.3.22 185  
36.4.2 47  
36.4.3 48  
36.4.4.1 51  
36.4.6.1 55  
36.4.8.5 59  
36.4.8.13 66  
36.4.8.18 71  
36.4.13.1 75  
36.4.13.2 75  
36.4.13.3 75  
36.4.13.4 75  
36.4.14 75  
36.4.17.1 79  
36.4.17.5 79  
36.4.17.24 79  
36.4.21 83  
36.13.1 88  
36.13.2 90  
36.13.4 92  
36.14.1 96  
36.14.3 97  
36.14.13 97  
36.14.16.25 113  
36.15.1 163  
36.15.2 163  
36.15.4 169  
36.16.1 172  
36.16.5 178  
36.16.10 180, 183  
36.16.10.3 185  
36.16.10.8 186  
36.16.10.13 186  
36.16.10.14 187  
36.16.10.16 187  
36.16.11 187  
36.16.12 189

36.16.13 191  
36.16.17 191  
36.16.22 196  
36.16.22.1 196  
36.16.22.2 198  
36.16.22.13 198  
36.17.5 204  
36.17.6 204  
36.19.1 210  
36.20.10.11 61  
36.20.10.15 84  
36.20.18 70  
36.22.1 211  
36.22.4 211  
36.22.13 172  
36.23.1 175, 212  
36.24.1 144  
36.24.13 212  
36.24.8 139  
36.25.90 212  
36.4.4.7 52

## A

All Domains display 53  
application server 208  
Application Usage Profile Report 186  
applicationcontrol.p 214  
applications, displaying registered 185  
AppServer Service Maintenance 210  
Archive File Reload 178  
archive/delete  
    audit detail 212  
    GL transactions 175  
    NRM sequences 33  
    programs 174  
    records from database 174  
ASCII data 173  
Audit Detail Delete/Archive 212

## B

Balance daemon 101  
bank driver installation  
    default directory settings 297  
Bank File Format Import 295  
Batch ID Maintenance 96  
batch processes 96  
Batch Request Detail Maintenance 97  
Batch Request Processor 97  
batchdelete field 168  
Booking Transaction Report 36  
Browse Maintenance 66

Browse URL Maintenance 61  
 browses  
   creating 56, 66  
   creating views for 70  
   lookups 56  
 Budget daemon 101  
 Bulk Data Load 139  
 Business Component View 54

**C**

calculat.p 56  
 calendars, shop 8  
 capacity  
   shift 10  
 change tracking  
   activating 35  
   specifying fields to track 35  
 Change Tracking Maintenance 34  
 CIM Data Load 163  
 CIM Data Load Process Monitor 169  
 CIM Data Load Processor 163  
 CIM interface 161–170  
   creating input file 166  
   database sequences 192  
   deleting records 168  
   error handling 168  
   input data format 164  
   invoking in batch 98  
   killing sessions of 169  
   multiple sessions 169  
   sample input 166  
 command line application control 214  
 comments  
   multiple languages 47  
   reporting master 204  
 components  
   customizing UI 156  
   e-mail notification for 82  
   viewing 54  
 concurrent session license 181  
 control programs  
   database 144  
   Label Control 79  
   System Maintain 145  
   System Settings 154  
   user settings 157  
 Control Tables Report 204  
 Corrupt Logging 179  
 Cross-Company daemon 102  
 cross-reference, system 204  
 CT log  
   viewing 153  
 Cube daemon 102  
 customers, shop calendar 8  
 customization  
   Process Incoming Bank Files 236  
 Customization Delete 263  
 customizing 250–272  
   enabling component UI 156  
   field help 75  
   function keys 73

**D**

Daemon Monitor 113

daemons 99–127  
   architecture 101  
   configure 106, 115  
   log file 107  
   monitor 110  
   monitor all 113  
   start 108  
   stop 109  
   users for 101  
 dashboards 83  
 data dictionary  
   changing 20  
   generalized codes 20  
 Database Control 144  
 Database File Size Inquiry 172  
 Database Sequence Initialization 191  
 database sequences 190–194  
 Database Table Dump/Load 173, 190  
 databases  
   dumping data 173  
   loading data 173  
   multiple languages 45  
   size management 172  
 daybooks 25  
 daylight savings time 196  
 default directory settings  
   for bank driver installation 297  
 delete/archive  
   audit detail 175, 212  
   GL transactions 175  
   NRM sequences 33  
   programs 174  
   restoring data 178  
 deleting records through CIM 168  
 design mode 250  
 Detailed License Violation Report 186  
 disk space  
   determining usage 172  
   freeing 172  
 Disk Space Inquiry 172, 212  
 Distribution Requirements Planning (DRP) 46  
 document formats, creating 92  
 domain cross reference  
   and bank driver installation 295  
 Down Time by Reason Report 22  
 draft, saved objects 159  
 drill-down browses 56  
   associating with field 57  
   creating 56, 66  
   drilling down on 58  
   wildcards with 58  
 Drill-Down/Lookup Maintenance 56  
   generalized codes 18, 19  
 dumping data 173

**E**

EC Number Range Maintenance 293  
 eCommerce Control 294  
 editor, segment 29  
 e-mail 80–83  
 E-Mail Definition Maintenance 81  
 Enforce Licensed User Count field 182  
 error messages 55  
 error messages, license violations 182

event configuration 118  
 Event daemon 117  
 event destination 117  
 executing menu items 49  
 Exit to Operating System 211

**F**

field help 74  
   adding to 75  
   book function 75  
   printing 75  
 Field Help Book Report 75  
 Field Help Maintenance 75  
 Field Help Report 75  
 fields  
   tracking changes 34  
 Form Code field 92  
 function keys  
   assigning menu items to 73  
   calling programs with 49  
   limitations 73

**G**

general ledger (GL) daybooks, number range management 25  
 generalized code groups 20  
   APP 20  
   synchronizing 22  
   SYSTEM 20  
 generalized codes  
   displaying list of 18, 56  
   example 18  
   validation 18  
 Generalized Codes Group Maint 20  
 Generalized Codes Maintenance 19, 21  
 Generalized Codes Sec. Browse 22  
 Generalized Codes Validation Report 18, 20  
 GL Audit Detail Delete/Archive 175  
 GL Op Transaction Control 204  
 GMT Offset field 197  
 GMT. *See* Greenwich Mean Time (GMT)  
 gpcode.v 20  
 Greenwich Mean Time (GMT) 197

**H**

help 74  
   printing 75  
   user 75  
 high water mark, licensing 187  
 History daemon 103  
 Holiday Maintenance 17

**J**

join types for views 71

**K**

killing CIM sessions 169

**L**

Label Control 79  
 Label Detail Maintenance 79  
 Label Master Maintenance 79  
 Language Detail Maintenance 47  
 languages

  defining 47  
   detail setup 47  
   implementing multiple 47  
   limitations 45  
   multiple 45  
   translating reports 48  
   Unicode restrictions 46  
 License Registration Menu 180, 183  
 License Violation Report 187  
 Licensed Application Report 185

licenses  
   concurrent session 181  
   displaying recorded license data 186  
   displaying registered applications 185  
   enforcing agreement 182  
   granting access to licensed applications 184  
   location 181  
   named user 181  
   removing 184  
   types 181  
   upgrading 184  
   violation reports 186  
   violation types 182

licensing  
   overview 181  
   recording high water mark 187

## links

  Browse URL Maintenance 61  
   external Web page 61, 62  
   other programs 63

loading data 173  
 loading time zones 198  
 location license 181  
 logging, database integrity 179  
 Logon History Archive/Delete 177  
 Lookup Browse 57  
 lookup browses 56  
   associating with field 58  
   creating 56, 66  
   for generalized codes 19

**M**

Master Comments Report 204  
 master production scheduling (MPS)  
   work orders, shop calendars 8  
 material requirements planning (MRP)  
   performance improvement 23  
   shop calendar 8  
 menu assignments 50  
 Menu Items by Field Report 205  
 Menu Items by Message Report 206  
 Menu Items by Table Report 206  
 Menu Substitution Maintenance 52  
 Menu System Maintenance 51  
 menus 49  
   assigning execution files 51  
   changing 51  
   cross-reference reports 205  
   security 50  
   structure 50  
 Message Maintenance 55  
 messages  
   license violations 182  
   modifying 55

- Progress 55
  - translating 55
- Messages by Menu Item Report 206
- mnemonic codes, changing 47
- monitoring users 189
- Multiple Time Zone Load Utility 198
- Multiple Time Zone Menu 196
- Multiple Time Zones Maintenance 196
- Multiple Time Zones Report 198

**N**

- named user license 181
- Number Range Maintenance 24
- number range management 25
- number range management (NRM) 23–34
  - segment editors 29
  - segment types 24
  - sequence definition 27
- number range sequences
  - for bank drivers 293
- Numbering function 194
- numbers
  - control segments 24
  - segment types 24
  - sequences 24

**O**

- OID generator code 144
- operating system
  - e-mail 81
  - multiple e-mail systems 81
- Operating System Commands menu 211
- Oracle database sequences 193

**P**

- planned work orders 8
- planning, change tracking 34
- Printer Default Maintenance 92
- Printer Setup Maintenance 90
- Printer Type Maintenance 88
- printers
  - control codes 89
  - default 92
  - max pages 91
  - setup 90
  - terminal 89
  - type definition 88
  - Windows/Unix setup 92
- printing help 75
- procedure help 74
- Procedure Help Report 75
- Process Incoming Bank Files
  - customizable matching logic 236
- Program Information Browse 53
- Program Information Maintenance 52
- Program Information Update 54
- Program Run Report 207
- Program Source File Report 206
- Program Summary Bill File Create 207
- Program/Text File Display 211
- Programs by Field Report 206
- Programs by Table Report 206
- Progress
  - application server 208

- document formats, creating with 92
- function key limitations 73
- messages 55
- multiple languages 45
- syntax for browses 70
- protermcap, function keys 74

**Q**

- qaduiConfig.xml 77

**R**

- reason codes
  - for change tracking 35
  - Sales Order Maintenance 22, 36
  - sales quotes and 22
  - shipment performance 23
  - shop floor control 22
- Reason Codes Maintenance 22
- registration, product 183
- removing licenses 184
- renewing licenses 184
- Replication daemon 104
- Report daemon 120
- Report Resource Designer 269
- Report Setup Menu 83
- Report Translation 48
- reporting licensing data 186
- reports, violations of license agreement 186
- restoring archived files 178
- Role Create 21
- Role Membership Maintain 50
- Role Permissions Maintain 21, 50
- Run Program Where-Used Detail 207

**S**

- Sales Order Maintenance 132
- sales quotes, reason lost 22
- sample data, time zones 198
- Save as Draft
  - draft objects 159
  - enabling 156
  - XML daemon 124
- Scan daemon 104
  - configure 115
- Secured items not on menu 21
- Secured items on menu 21
- security, menu 50
- segment editors 29
- Sequence Delete/Archive 33
- Sequence Maintenance 191
- Sequence Number History Report 33
- Sequence Number Maintenance 32
- sequences
  - database 190–194
  - number range management (NRM) 23
- server time zone 144
- server.xml 154
- Session Master Maintenance 84
- set debug level 151
- settings, user 157
- shifts
  - capacity 10
- shipping, number range management 26
- shop calendar 8

- shop floor control, reason codes 22
  - Source File Where-Used Detail 207
  - Source File Where-Used Summary 207
  - Statutory-Currency Utility 212
  - Summary License Violation Report 187
  - suppliers, shop calendar 8
  - system codes 149
  - system constants
    - calendars 8
    - change tracking 34
    - generalized codes 18
    - holidays 8
    - number sequences 23
    - reason codes 22
  - system cross-reference 204, 205
  - customizing 204
    - rebuilding procedure 208
    - updating 208
  - System Maintain 145
  - System Monitor 150
  - System Settings 154
  - System Synchronize 148
- T**
- Tables/Fields by Menu Report 205
  - Tables/Fields by Program Report 205
  - telnet server
    - connection settings, configuring 78
    - login sequence, configuring 76
    - port number 76
    - setting up 75
    - verifying on UNIX 79
  - terminal mode 53
  - Time Out daemon 105
  - time zones
    - based on offset from GMT 196
    - creating 196
    - defining 196
    - deleting 198
    - loading sample data 198
    - reloading 198
    - server 144
    - tracking daylight savings time 196
  - tracking changes 34
  - translation activities report 48
- U**
- Unicode
    - batch processing 98
    - restrictions 46
  - Unicode database, multiple languages 45
  - uniform resource locators (URLs), browse links 61
  - uniform resource name (URN) 51
  - Unposted GL Transaction Correction 204
  - Unposted Transaction Inquiry 175
  - upgrading licenses 184
  - URN. *See* uniform resource name
  - User Access by Application Inquiry 185
  - User Count Audit Process Report 187
  - user interface
    - .NET UI 41, 49
    - character 18, 41, 45, 46, 49
    - component functions 41
    - customization 220, 250
      - delete 263
      - design mode 250
      - user-defined fields 265
  - User Maintenance
    - e-mail definition 81
    - language 47
  - User Menu 49, 73
  - User Monitor Inquiry 189
  - User Option Telnet Maintenance 75, 78
  - User Tool Maintenance 59
  - user-defined fields 265
    - adding fields to QRF reports 269
  - User-Defined Fields on Report Maintain 270
  - users
    - daemon 101
    - deactivating access to applications 185
    - function keys 73
    - granting access to licensed applications 184
    - language 47
    - menu 49
    - monitoring 189
    - settings for 157
    - sys admin login 146
    - telnet login 76
  - utdbfx70.p 20
- V**
- validating user input 20
  - View CT log 153
  - View Maintenance 70, 71
  - View System Codes 149
  - views 70
  - violations of license agreement 181
- W**
- warning messages, license violations 182
  - wildcards, assigning browses 58
  - workflow
    - delete 159
    - enabling 157
    - setting up 159
- X**
- XML daemon 123
    - Configure 124

